

300
PSI

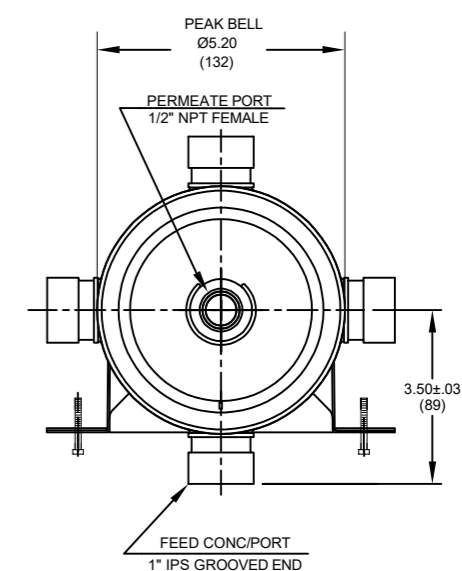

CAUTION: INCORRECT MANIFOLDING WILL CAUSE SEVERE LOCAL STRESS AROUND PORT AND MAY RESULT IN LEAKS AND PREMATURE FAILURE; TAKE EVERY PRECAUTION LISTED ON PAGE 02, SEE INSTALLATION INSTRUCTIONS FOR FURTHER DETAILS

DWG REF	QTY	PART NUMBER	DESCRIPTION	MATERIAL
SHELL				
1*	1	200121	SHELL	Filament Wound Epoxy/Glass composites - Head locking grooves integrally wound in place.
2*	A/R	A/R	F/C Port	SA-351 CF8M
3	A/R	196596	F/C Port Seal	Ethylene Propylene - O - Ring
HEAD				
4*	2	PWG195042	Bearing Plate Assembly	-
4.1*	1	96803	Bearing Plate	SA-479 316L
4.2	1	96799	Danger Label	-
5	2	96855	Sealing Plate	Engineering Thermoplastic.
6	2	196266	Head Seal	Ethylene Propylene - O - Ring
7	2	96807	Permeate Port	Engineering Thermoplastic.
8	2	196274	Permeate Port Seal	Ethylene Propylene - Square Cut
9	2	45242	Port Retainer	PH-15-7Mo Stainless Steel
HEAD INTERLOCK				
10*	2	45260	Spiral Ring	SA-479 316
VESSEL SUPPORT				
11	2*	45058	Saddle	Engineering Thermoplastic.
12	2*	47459	Strap Assy.	304 Stainless Steel-PVC Cushion.
13	4**	97821	Strap Screw	5/16-18 UNC x 1.5" Long, 304 Stainless Steel
ELEMENT INTERFACE				
14	2	A/R	Adapter	Engineering Thermoplastic.
15	2	196271	Adapter seal	Ethylene Propylene - O - Ring
16	A/R	A/R	PWT seal	Ethylene Propylene - O - Ring

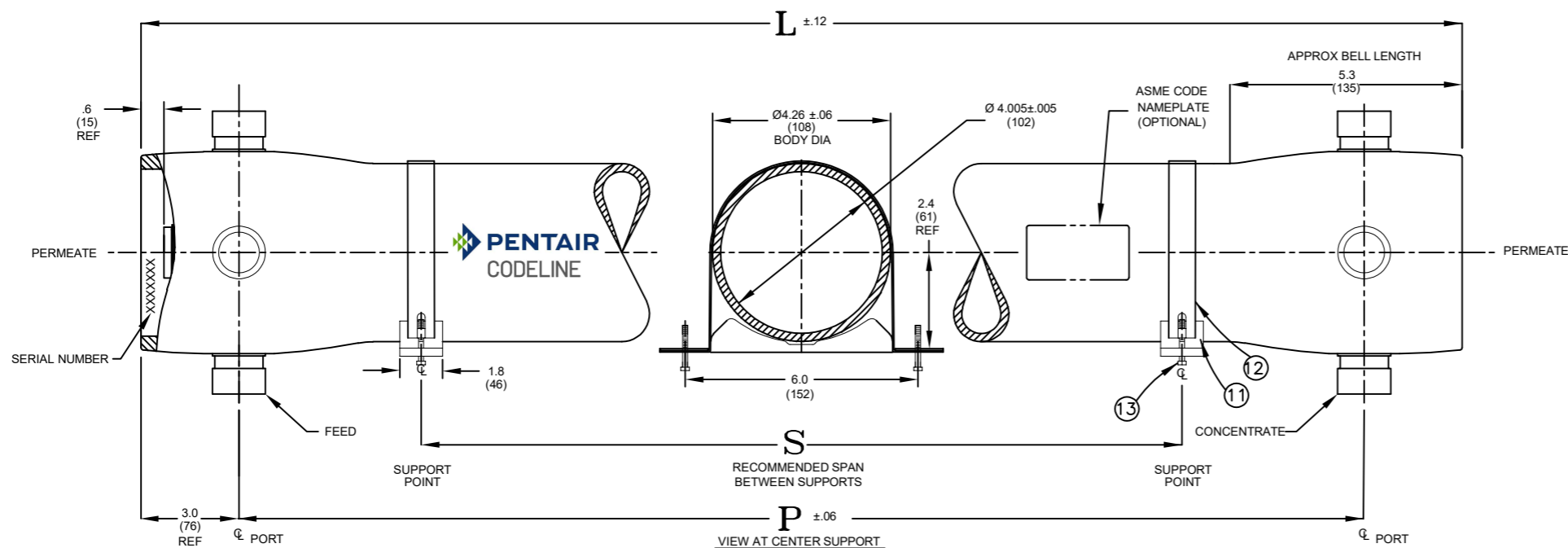
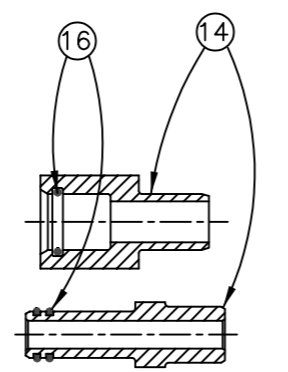

PORT SIZE CODE	
A	¼ NPT FEMALE
B	¼ BSPT FEMALE
C	1" GROOVED END

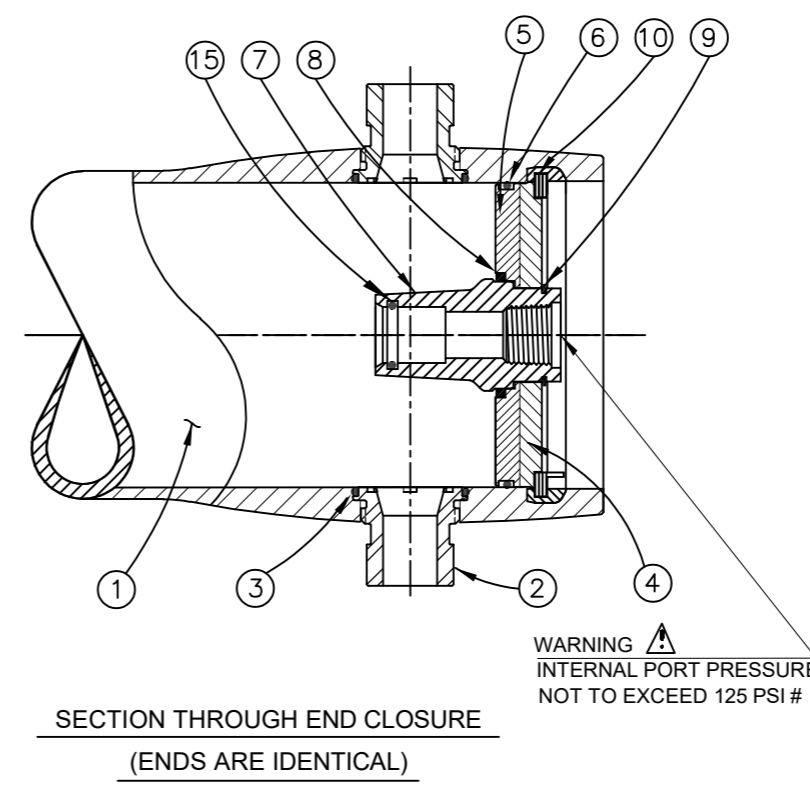

Dash Length	PORT LOCATION			Approx Weight LB(KG)**
	L IN(MM)	P IN(MM)	S IN(MM)	
-1	48.00 (1219)	42.00 (1067)	25X1 (635)	18 (8)
-2	88.00 (2235)	82.00 (2083)	56X1 (1422)	24 (11)
-3	128.00 (3251)	122.00 (3099)	80X1 (2032)	31 (14)
-4	168.00 (4267)	162.00 (4115)	64X2 (1626)	37 (17)
-5	208.00 (5283)	202.00 (5131)	78X2 (1981)	44 (20)
-6	248.00 (6299)	242.00 (6147)	92X2 (2337)	53 (24)

GENERAL NOTES:
 1. MAX. ANGULAR VARIATION BETWEEN ANY PORT ±0.5°.
 2. DIMENSIONS IN INCHES (MM APPROX)
 3. SHELL EXTERIOR COATED WITH WHITE RAL 9003, HIGH GLOSS POLYURETHANE PAINT.
 4. NOT TO BE USED FOR CONSTRUCTION UNLESS CERTIFIED
 # 300 PSI FOR METALLIC PERMEATE PORT. FOR OPTIONAL PART NUMBERS, REFER PAGE 2
 * ASME PARTS.
 ** WEIGHTS GIVEN IN THE TABLE ARE FOR HIGHEST CONFIGURATION AND WILL VARY WITH CHANGE IN CONFIGURATION.

THIS DOCUMENT AND THE INFORMATION CONTAINED HEREIN, ARE THE CONFIDENTIAL AND PROPRIETARY INFORMATION OF PENTAIR WATER INDIA PVT. LTD. PENTAIR WATER INDIA PVT. LTD. IS THE SOLE OWNER OF THE INFORMATION AND PROCESSES DEFINED HEREIN. THIS DOCUMENT, AND THE INFORMATION CONTAINED, MAY NOT BE DISCLOSED, REPRODUCED, DUPLICATED, USED, SOLD, PUBLISHED, COMMUNICATED OR OTHERWISE DISTRIBUTED, IN WHOLE OR IN PART, FOR ANY PURPOSE WITHOUT THE EXPRESS WRITTEN CONSENT OF PENTAIR WATER INDIA PVT. LTD. THIS DOCUMENT AND ANY COPIES, IN ALL APPLICABLE FORMATS, SHALL BE RETURNED TO PENTAIR WATER INDIA PVT. LTD. UPON REQUEST.

ALL INDICATED PENTAIR TRADEMARKS AND LOGOS ARE PROPERTY OF PENTAIR. THIRD PARTY REGISTERED AND UNREGISTERED TRADEMARKS AND LOGOS ARE PROPERTY OF THEIR RESPECTIVE OWNERS. BECAUSE WE ARE CONTINUOUSLY IMPROVING OUR PRODUCTS AND SERVICES, PENTAIR RESERVES THE RIGHT TO CHANGE SPECIFICATIONS WITHOUT PRIOR NOTICE. PENTAIR IS AN EQUAL OPPORTUNITY EMPLOYER.

© 2021 Pentair. All Rights Reserved.

PENTAIR CODELINE VERNA, GOA INDIA

DRAWN BY: YPS	DRAWING DESCRIPTION: MODEL - 40S30 MEMBRANE HOUSING	DRAWING NO.: 200339	REV.: D
DATE: 25JAN24	CUSTOMER NAME:	VESSEL MODEL: 40S30	
CHECKED BY: KPS	DATE: 25JAN24	PROJECT NAME:	TOTAL QTY: -
APPROVED BY: FF	DATE: 25JAN24	CUSTOMER P.O.#:	SIZE: A3
PCO NO.: 549013	REV. DATE: 20NOV25	SCALE: NONE	PAGE NO.: 01 OF 02

RATING:

DESIGN PRESSURE/MAWP.....	300 PSI (2.07 MPa) PVC/PET
MAX. ALLOWABLE TEMP.....	120°F/190°F (49°C/88°C)
MIN. ALLOWABLE TEMP	20°F (-7°C)
FACTORY TEST PRESSURE.....	330 PSI (2.28 MPa)
BURST PRESSURE.....	1800 PSI (12.41 MPa)

INTENDED USE:

The Model 40S30 Fiberglass RO/UF Pressure Vessel is designed for continuous, long term use as housing for reverse osmosis and ultrafiltration elements in typical industrial water treatment systems at pressures up to 300 psi. Any make of four-inch nominal diameter spiral-wound element is easily accommodated. The appropriate interfacing hardware for the element specified is furnished with the vessel.

The Model 40S30 is designed in accordance with the engineering standards of the Boiler and Pressure Vessel Code of the American Society of Mechanical Engineers (ASME Code) Section X Edition 2025. F/C port, Bearing plate and Quick release spiral ring are designed as per Section VIII Division I Edition 2025.

At small additional cost, vessels can be inspected during construction by an ASME Authorized inspector and ASME Code stamped.

The Model 40S30 must be installed, operated and maintained in accordance with the listed precautions and good industrial practice to assure safe operation over a long service life.

The high performance reinforced plastic shell must be allowed to expand under pressure; undue restraint at support points or piping connections can cause leaks to develop in the shell. This side ported vessel requires special precautions in mounting and connection to piping so that the vessel will not be subjected to excessive stress due to bending moments acting at the side openings in the fiberglass shell.

The end closures, incorporating close-fitting, interlocking metal components, must be kept dry and free of corrosion; deterioration can lead to catastrophic mechanical failure of the heads.

Pentair will assist the purchaser in determining the suitability of this standard vessel for their specific operating conditions. The final determination however, including evaluation of the standard material of construction for compatibility with the specific corrosive environment, shall be the responsibility of the purchaser. Alternate materials with enhanced corrosion resistance are available on special order.

Specifications are subject to change without notice.

PRECAUTIONS:

- DO...read, understand, and follow all instructions; failure to take every precaution will void warranty and may result in vessel failure.
- DO...mount the shell on horizontal members at span "S" using compliant vessel supports furnished; shim saddles if required. Tighten hold down straps just snug.
- DO...align and center side ports with the manifold header. Correct, causes of misalignment in a row of vessels connected to the same header.
- DO...use flexible type IPS grooved-end pipe couplings, at side ports; allow full, 0.125-inch gap between port and piping, and position piping to maximize flexibility of connection.
- DO...provide flexibility in, and support for piping manifolds so that vessel can grow in length under pressure without undue restraint; provide additional flexible joints in large pipes leading to manifold header.
- DO...provide overpressure protection for vessel set at not more than 105% of design pressure.
- DO...inspect end closures regularly; replace components that have deteriorated and correct causes of corrosion.
- DO... Lubricate seals sparingly, using nonpetroleum based lubricants, i.e. Glycerin or suitable lubricants.
- DO NOT...work on any component until first verifying that pressure is relieved from vessel.
- DO NOT... make rigid piping connections to ports or clamp vessel in any way that resists growth of fiberglass shell under pressure; ΔDIA = 0.01 in. (0.25mm) and ΔL = 0.140 in. (3.5mm) for a length code -6 vessel
- DO NOT... hang piping manifolds from ports or use vessel in any way to support other components.
- DO NOT...tighten Permeate Port connection more than one turn past hand tight.
- DO NOT... operate vessel without connecting both Permeate Ports internally to complete set of elements or otherwise plug ports internally so that external piping connection is not subjected to feed pressure.
- DO NOT...pressurize vessel until double-checking to verify that the Locking Ring is in place and fully seated.
- DO NOT... operate vessel at pressures and temperatures in excess of its rating.
- DO NOT... operate vessel with permeate pressure in excess of 125 psi.
- DO NOT... tolerate leaks or allow end closures to be routinely wetted in any way.
- DO NOT... operate outside the pH range 3-11.
- DO NOT...operate outside the pH range 2-12 for cleaning.
- DO NOT...exceed 43.2 hours in a year for cleaning with above mentioned pH range.

For complete information on proper use of the vessel Please refer to 40S series USER'S GUIDE - 96897

CAUTION:
EYE PROTECTION SHOULD BE WORN WHEN REMOVING OR INSTALLING RETAINING RINGS. KEEP FINGERS CLEAR FROM RETAINING RING WHILE INSTALLING LAST OF TWO TURNS. RING MAY SNAP INTO POSITION POSSIBLY PINCHING FINGERS.

ORDERING:

Using the chart below, please select the features you require.

VESSEL LENGTH CODE – please select.

MODEL 40S30 -1 -2 -3 -4 -5 -6

MEMBRANE BRAND AND MODEL

Please supply adapters for the following membrane brand and specific model
Brand _____ Model _____

CERTIFICATION REQUIRED

- Hydro testing at 1.1 times the design pressure.
- CE Marked – MODULE-D1, CATEGORY-2 (Not applicable for -1 length vessel)
- ASME Stamped and National Board Registered.

EXTERIOR FINISH

White high-gloss RAL 9003 polyurethane coating over sanded surface.

FEED PORT CONFIGURATION

- 1" IPS Grooved End
- Multi-Ports, Port clocking.

PERMEATE PORT CONFIGURATION

Serial number	Opposite	PERMEATE PORT MATERIAL
End	End	
<input type="checkbox"/>	<input type="checkbox"/>	-PET
<input type="checkbox"/>	<input type="checkbox"/>	-PVC (120°F maximum)
<input type="checkbox"/>	<input type="checkbox"/>	-316L Stainless Steel
		PERMEATE PORT SIZE
<input type="checkbox"/>	<input type="checkbox"/>	- 1/2" NPT Female (Standard per drawing)
<input type="checkbox"/>	<input type="checkbox"/>	- 1/2" BSPT/JISPT Female
<input type="checkbox"/>	<input type="checkbox"/>	- 1/2" BSPP/JISPP Female

Please fill out your feed port configuration in the space below.

List port location first followed by port size for each choice.

Serial number end
Opposite end

NOTE: For vessel rating to be at 190°F sealing plate material will be PET.

	PORT SIZE CODE	PART NO.
A	3/4" NPT FEMALE	196612
B	3/4" BSPT FEMALE	196615
C	1" GROOVED END	196569

NOTE
Spiral Retaining Ring Removal Tool (50303) is recommended opening and closing vessel.

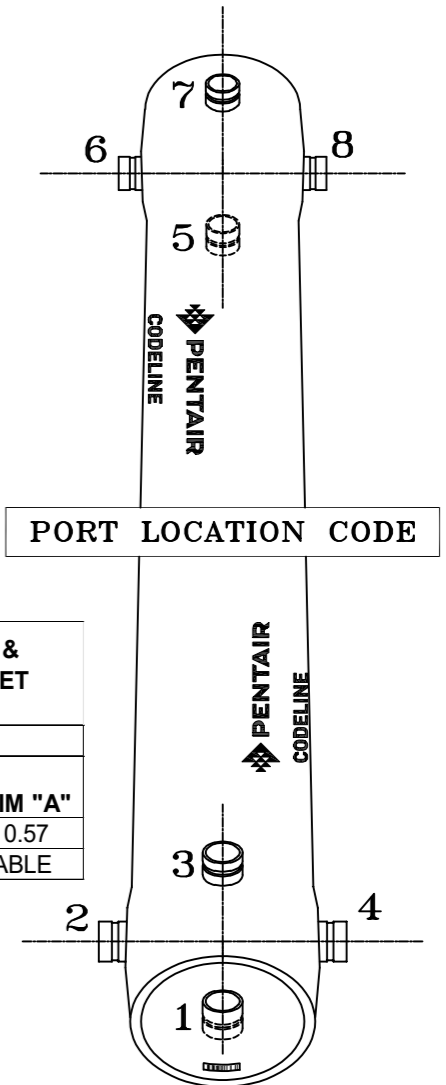

PERMEATE PORT PART NUMBERS & PERMPORT TO VESSEL FACE OFFSET DISTANCE			
SIZE	MATERIAL	BSPPF	
		PART NUMBER	DIM "A"
1/2"	PET	96887	0.57
	PVC	NOT APPLICABLE	

1. PLEASE REFER TO 201421 FOR TRI-CLOVER DETAILS.

THIS DOCUMENT AND THE INFORMATION CONTAINED HEREIN, ARE THE CONFIDENTIAL AND PROPRIETARY INFORMATION OF PENTAIR WATER INDIA PVT. LTD. PENTAIR WATER INDIA PVT. LTD. IS THE SOLE OWNER OF THE INFORMATION AND PROCESSES DEFINED HEREIN. THIS DOCUMENT, AND THE INFORMATION CONTAINED, MAY NOT BE DISCLOSED, REPRODUCED, DUPLICATED, USED, SOLD, PUBLISHED, COMMUNICATED OR OTHERWISE DISTRIBUTED, IN WHOLE OR IN PART, FOR ANY PURPOSE WITHOUT THE EXPRESS WRITTEN CONSENT OF PENTAIR WATER INDIA PVT. LTD. THIS DOCUMENT AND ANY COPIES, IN ALL APPLICABLE FORMATS, SHALL BE RETURNED TO PENTAIR WATER INDIA PVT. LTD. UPON REQUEST.

ALL INDICATED PENTAIR TRADEMARKS AND LOGOS ARE PROPERTY OF PENTAIR. THIRD PARTY REGISTERED AND UNREGISTERED TRADEMARKS AND LOGOS ARE PROPERTY OF THEIR RESPECTIVE OWNERS. BECAUSE WE ARE CONTINUOUSLY IMPROVING OUR PRODUCTS AND SERVICES, PENTAIR RESERVES THE RIGHT TO CHANGE SPECIFICATIONS WITHOUT PRIOR NOTICE. PENTAIR IS AN EQUAL OPPORTUNITY EMPLOYER.

		PENTAIR CODELINE		VERNA, GOA INDIA	
DATE: 25JAN24	CHECKED BY: KPS	CUSTOMER NAME: -	VESSEL MODEL: 40S30		
DATE: 25JAN24	APPROVED BY: FF	PROJECT NAME: -	TOTAL QTY: -		
DATE: 25JAN24	PCO NO.: 549013	CUSTOMER P.O.#: -	SIZE: A3	SCALE: NONE	PAGE NO.: 02 OF 02
REV. DATE: 20NOV25					