

VIEW AT CENTER SUPPORT
 CENTER VESSEL ON 2 OR 3 SUPPORTS
 AT SPAN(S) "S" : 3 SUPPORTS REQUIRED
 FOR LENGTHS -4 AND ABOVE

PORT SIZE CODE	
D	1 1/2" GROOVED END
E	2" GROOVED END
F	2 1/2" GROOVED END
G	3" GROOVED END

CAUTION: INCORRECT MANIFOLDING
 WILL CAUSE SEVERE LOCAL STRESS
 AROUND PORT AND MAY RESULT IN
 LEAKS AND PREMATURE FAILURE;
 TAKE EVERY PRECAUTION LISTED
 ON REVERSE, SEE INSTALLATION
 INSTRUCTIONS FOR FURTHER DETAILS

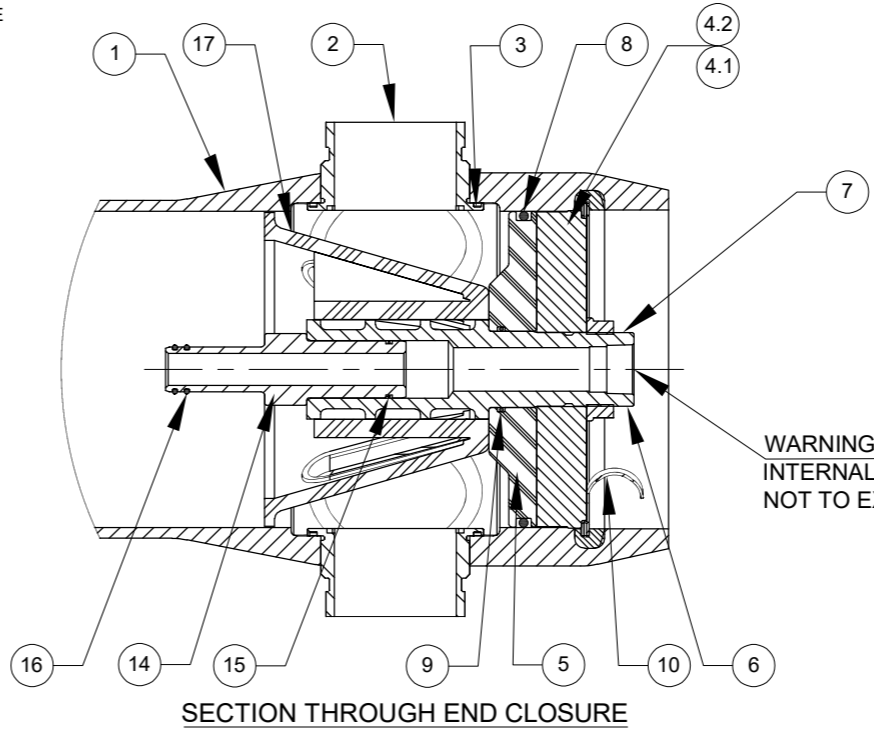

NO. OF PORTS	PORT LOCATION	VESSEL QTY.		
Dash Length	L IN(MM)	P IN(MM)	S IN(MM)	Approx Weight LB(KG)**
-1	64.15 (1629)	47 (1194)	10X1 (254)	196 (89)
-2	104.15 (2645)	87 (2210)	50X1 (1270)	238 (108)
-3	144.15 (3661)	127 (3226)	80X1 (2032)	277 (126)
-4	184.15 (4677)	167 (4242)	64X2 (1626)	317 (144)
-5	224.15 (5693)	207 (5258)	78X2 (1981)	355 (161)
-6	264.15 (6709)	247 (6274)	92X2 (2337)	396 (180)
-7	304.15 (7725)	287 (7290)	106X2 (2692)	443 (201)
-8	344.15 (8741)	327 (8306)	120X2 (3048)	485 (220)

DWG REF	QTY	PART NUMBER	DESCRIPTION	MATERIAL
SHELL				
1*	1	99225	SHELL	Filament Wound Epoxy/Glass composite - Head locking grooves integrally wound in place.
2*	A/R	A/R	F/C Port	SA-995 (J93380) CD3MW CuN
3	A/R	A/R	F/C Port Seal	Ethylene Propylene
HEAD				
4	2	194468	Bearing Plate Assembly	-
4.1*	1	96158	Bearing Plate	SB-221 A96061-T6
4.2	1	96184	Danger Label	-
5	2	96159	Sealing Plate	Engineering Thermoplastic.
6	2	96161	Permeate Port	Engineering Thermoplastic.
7	2	45066	Port Nut	Engineering Thermoplastic.
8	2	196223	Head Seal	Ethylene Propylene - O - Ring
9	2	196215	Perm Port Seal	Ethylene Propylene - O - Ring
HEAD INTERLOCK				
10*	2	47336	Quick Release Retaining Ring	SA-479 316
VESSEL SUPPORT				
11	2*	52169	Saddle	Engineering Thermoplastic.
12	2*	45042	Strap Assy.	304 Stainless Steel-PVC Cushion.
13	4**	46265	Strap screw.	5/16-18 UNC, 2.5" L, 304 Stainless Steel.
ELEMENT INTERFACE				
14	2	A/R	Adapter	Engineering Thermoplastic.
15	2	196222	Adapter seal	Ethylene Propylene - O - Ring
16	4	A/R	PWT Seal	Ethylene Propylene - O - Ring
17	1	96163	Thrust Cone	Engineering Thermoplastic.

*3 & **6 each furnished with length code 4,5,6,7&8.

GENERAL NOTES:
 1. MAX. ANGULAR VARIATION BETWEEN ANY PORT ±0.5°.
 2. DIMENSION IN INCHES (MM APPROX.).
 3. SHELL EXTERIOR COATED WITH WHITE RAL 9003, HIGH GLOSS POLYURETHANE PAINT.
 4. ITEM 17 DOWNSTREAM ONLY.
 5. NOT TO BE USED FOR CONSTRUCTION UNLESS CERTIFIED BY PENTAIR.
 # 600 PSI FOR METALLIC PERMEATE PORT. FOR OPTIONAL PART NUMBERS, REFER PAGE 3.
 * ASME PARTS.
 ** WEIGHTS GIVEN IN THE TABLE ARE FOR HIGHEST CONFIGURATION AND WILL VARY WITH CHANGE IN CONFIGURATION.

THIS DOCUMENT AND THE INFORMATION CONTAINED HEREIN, ARE THE CONFIDENTIAL AND PROPRIETARY INFORMATION OF PENTAIR WATER INDIA PVT. LTD. PENTAIR WATER INDIA PVT. LTD. IS THE SOLE OWNER OF THE INFORMATION AND PROCESSES DEFINED HEREIN. THIS DOCUMENT, AND THE INFORMATION CONTAINED, MAY NOT BE DISCLOSED, REPRODUCED, DUPLICATED, USED, SOLD, PUBLISHED, COMMUNICATED OR OTHERWISE DISTRIBUTED, IN WHOLE OR IN PART, FOR ANY PURPOSE WITHOUT THE EXPRESS WRITTEN CONSENT OF PENTAIR WATER INDIA PVT. LTD. THIS DOCUMENT AND ANY COPIES, IN ALL APPLICABLE FORMATS, SHALL BE RETURNED TO PENTAIR WATER INDIA PVT. LTD. UPON REQUEST.

ALL INDICATED PENTAIR TRADEMARKS AND LOGOS ARE PROPERTY OF PENTAIR. THIRD PARTY REGISTERED AND UNREGISTERED TRADEMARKS AND LOGOS ARE PROPERTY OF THEIR RESPECTIVE OWNERS. BECAUSE WE ARE CONTINUOUSLY IMPROVING OUR PRODUCTS AND SERVICES, PENTAIR RESERVES THE RIGHT TO CHANGE SPECIFICATIONS WITHOUT PRIOR NOTICE. PENTAIR IS AN EQUAL OPPORTUNITY EMPLOYER.

© 2021 Pentair. All Rights Reserved.

**PENTAIR
CODELINE**

VERNA, GOA
INDIA

DRAWN BY: PGS	DATE: 27JAN06	DRAWING DESCRIPTION: MODEL - 80H120 MEMBRANE HOUSING	DRAWING NO.: 99170	REV.: AJ
CHECKED BY: MD	DATE: 27JAN06	CUSTOMER NAME: -	VESSEL MODEL: 80H120	
APPROVED BY: RM	DATE: 27JAN06	PROJECT NAME: -	TOTAL QTY: -	
PCO NO.: 548441	CUSTOMER P.O.#: -	SIZE: A3	SCALE: NONE	PAGE NO.: 01 OF 03
REV. DATE: 17OCT25				

RATING:

DESIGN PRESSURE/MAWP.....	1200 PSI (8.27 MPa)
MAX. ALLOWABLE TEMP.....	150°F (66°C)
MIN. ALLOWABLE TEMP.....	20°F (-7°C)
FACTORY TEST PRESSURE.....	1320 PSI (9.10 MPa)
QUALIFICATION PRESSURE	7200 PSI (49.64 MPa)

INTENDED USE:

The CodeLine 80H120 Fiberglass RO Pressure Vessel is designed for continuous, long term use as housing for reverse osmosis membrane elements to desalt typical sea waters at pressures up to 1200 psi. Any make of eight-inch nominal diameter spiral-wound element is easily accommodated; the appropriate interfacing hardware for the element specified is furnished with the vessel.

The CodeLine 80H120 is designed in accordance with the engineering standards of the Boiler and Pressure Vessel Code of the American Society of Mechanical Engineers (ASME) as per Section X Edition 2025. F/C port, Bearing plate and Quick release spiral ring are designed as per ASME Section VIII Division I Edition 2025.

At small additional cost vessels can be inspected during construction by an ASME Authorized Inspector and ASME Code stamped.

The CodeLine 80H120 must be installed, operated and maintained in accordance with the listed precautions and good industrial practice to assure safe operation over a long service life.

The high performance Filament wound FRP shell must be allowed to expand under pressure; undue restraint at support points or piping connections can cause leaks to develop in the shell. This side-ported vessel requires special precautions in mounting and connection to piping so that the vessel will not be subjected to excessive stress due to bending moments acting at the side openings in the fiberglass shell. The end closure, incorporating close fitting, interlocking metal components, must be kept dry and free of corrosion; deterioration can lead to catastrophic mechanical failure of the head.

Pentair will assist the purchaser in determining the suitability of this standard vessel for their specific operating conditions. The final determination however, including evaluation of the standard material of construction for compatibility with the specific corrosive environment, shall be the responsibility of the purchaser. Alternate materials with enhanced corrosion resistance are available on special order.

Specifications are subject to change without notice.

PRECAUTIONS:

- DO...read, understand and follow all instructions; failure to take every precaution will void warranty and may result in vessel failure
- DO...mount the shell on horizontal members at span "S" using compliant vessel supports furnished; Shim saddles if required. Tighten hold down straps just snug
- DO...align and center side ports with the manifold header. Correct, causes of misalignment in a row of vessels connected to the same header
- DO...use flexible type IPS grooved-end pipe couplings, at side ports; allow full, 0.125 inch gap between port and piping, and position piping to maximize flexibility of connection.
- DO...provide flexibility in, and support for piping manifolds so that vessel can grow in length under pressure without undue restraint; provide additional flexible joints in large pipes leading to manifold header.
- DO...provide overpressure protection for vessel set at not more than 105% of design pressure
- DO...inspect end closures regularly; replace components that have deteriorated and correct causes of corrosion
- DO... Lubricate seals sparingly, using nonpetroleum based lubricants, i.e. Glycerine or suitable lubricants
- DO NOT...work on any component until first verifying that pressure is relieved from vessel
- DO NOT...make rigid piping connections to ports or clamp vessel in any way that resists growth of fiberglass shell under pressure;
 - ***ΔDIA = 0.015 in. (0.4mm) and
 - ***ΔL = 0.2 in. (5mm) for a length code -8 vessel
- DO NOT... hang piping manifolds from ports or use vessel in any way to support other components
- DO NOT...tighten Permeate Port connection more than one turn past hand tight
- DO NOT... operate vessel without connecting both Permeate Ports internally to complete set of elements or otherwise plug ports internally so that external piping connection is not subjected to feed pressure
- DO NOT...install Spacer on downstream end of vessel
- DO NOT...operate vessel without Thrust Cone installed downstream
- DO NOT...pressurize vessel until double-checking to verify that the Locking Ring is in place and fully seated.
- DO NOT...operate vessel at pressure and temperature in excess of its rating.
- DO NOT...operate vessel with permeate pressure in excess of 125 psi at 150°F (0.86 Mpa at 66°C).
- DO NOT...tolerate leaks or allow end closures to be routinely wetted in any way
- DO NOT...operate outside the pH range 3-11.
- DO NOT...operate outside the pH range 2-12 for cleaning.
- DO NOT...exceed 432 hours in a year for cleaning with above mentioned pH range.

For complete information on proper use of the vessel Please refer to the 80H Series USER'S GUIDE 94182.

ORDERING:

Using the chart below, please check the features you require

VESSEL LENGTH CODE – please check one

MODEL 80H120 -1 -2 -3 -4 -5 -6 -7 -8

MEMBRANE BRAND AND MODEL

Please supply adapters for the following membrane brand and specific model
Brand _____ Model _____

CERTIFICATION REQUIRED

- Hydro testing at 1.1 times the design pressure.
- CE Marked – MODULE-D1, CATEGORY2.
- ASME Stamped and National Board Registered.

ADAPTER KITS	
UP STREAM	DOWN STREAM

PERMEATE PORT SELECTION

Serial Number End

Size of the Permeate Port 1" 1.25" 1.5"
 Type of Connection FNPT MNPT BSPTM BSPTF IPST BSPPF BSPPM
 Material of Construction Noryl SS316L Zeron 100

Non Serial Number End

Size of the Permeate Port 1" 1.25" 1.5"
 Type of Connection FNPT MNPT BSPTM BSPTF IPST BSPPF BSPPM
 Material of Construction Noryl SS316L Zeron 100

Note:

- Refer to Page 3 for available permeate port options.

STRAP ASSEMBLY

SS304 SS316 SS316L

FEED/CONCENTRATE PORT SELECTION

Material of Construction Super Duplex SS (CD3MWCuN)
 - CE3MN* (Cannot be offered for ASME stamped vessels)

Configuration - CD3MWCuN 1G5G
 -Multi port:
 Ports not available in 90° configurations.

Serial number end

Opposite end

BEARING PLATE MATERIAL

- A96061 T6 Aluminium
 - Stainless Steel 316L

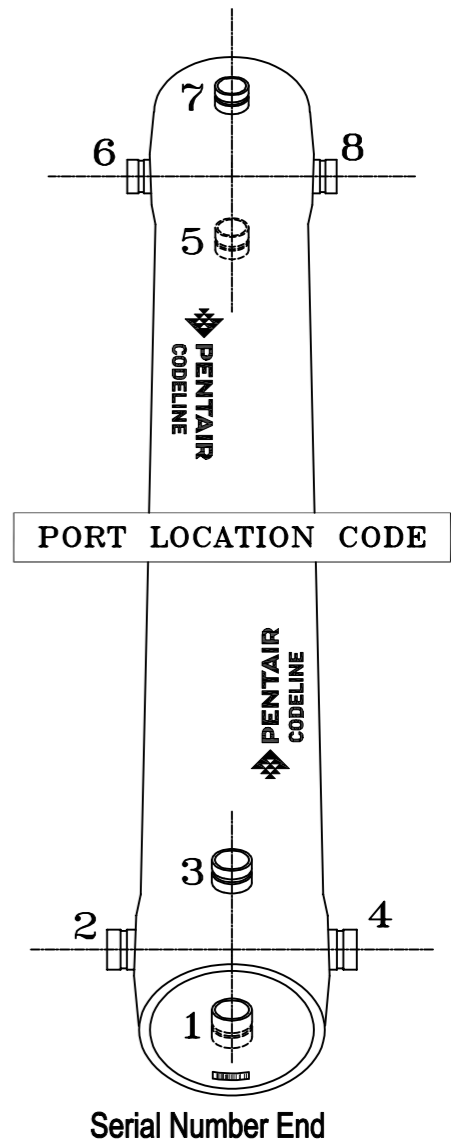

CODELINE BODY LABELS ARE PLACED AT 90° ON SERIAL NUMBER END AND AT 270° ON THE OPPOSITE SIDE END

GENERAL NOTES:

1. PLEASE REFER TO 201414 FOR TRICLOVER DETAILS AND REFER PAGE-3 FOR OPTIONAL PART NUMBERS.

THIS DOCUMENT AND THE INFORMATION CONTAINED HEREIN, ARE THE CONFIDENTIAL AND PROPRIETARY INFORMATION OF PENTAIR WATER INDIA PVT. LTD. PENTAIR WATER INDIA PVT. LTD. IS THE SOLE OWNER OF THE INFORMATION AND PROCESSES DEFINED HEREIN. THIS DOCUMENT, AND THE INFORMATION CONTAINED, MAY NOT BE DISCLOSED, REPRODUCED, DUPLICATED, USED, SOLD, PUBLISHED, COMMUNICATED OR OTHERWISE DISTRIBUTED, IN WHOLE OR IN PART, FOR ANY PURPOSE WITHOUT THE EXPRESS WRITTEN CONSENT OF PENTAIR WATER INDIA PVT. LTD. THIS DOCUMENT AND ANY COPIES, IN ALL APPLICABLE FORMATS, SHALL BE RETURNED TO PENTAIR WATER INDIA PVT. LTD. UPON REQUEST.

ALL INDICATED PENTAIR TRADEMARKS AND LOGOS ARE PROPERTY OF PENTAIR. THIRD PARTY REGISTERED AND UNREGISTERED TRADEMARKS AND LOGOS ARE PROPERTY OF THEIR RESPECTIVE OWNERS. BECAUSE WE ARE CONTINUOUSLY IMPROVING OUR PRODUCTS AND SERVICES, PENTAIR RESERVES THE RIGHT TO CHANGE SPECIFICATIONS WITHOUT PRIOR NOTICE. PENTAIR IS AN EQUAL OPPORTUNITY EMPLOYER.

PENTAIR		VERNA, GOA INDIA	
CODELINE			
DRAWN BY: PGS	DATE: 27JAN06	DRAWING DESCRIPTION: MODEL - 80H120 MEMBRANE HOUSING	DRAWING NO.: 99170
CHECKED BY: MD	DATE: 27JAN06	CUSTOMER NAME: -	REV.: AJ
APPROVED BY: RM	DATE: 27JAN06	PROJECT NAME: -	VESSEL MODEL: 80H120
PCO NO.: 548441	REV. DATE: 17OCT25	CUSTOMER P.O.#: -	TOTAL QTY: -
		SIZE: A3	SCALE: NONE
			PAGE NO.: 02 OF 03

++ BEARING PLATE PART NUMBERS		
PERMEATE PORT SIZE	ALUMINIUM	SS F316L ###
1.0"/1.25"	194468	195194
1.5	194499	195193

STRAP ASSEMBLY PART NUMBERS		
SS 304	SS 316	SS 316L
45042	46926 ⁺	94371 ⁺

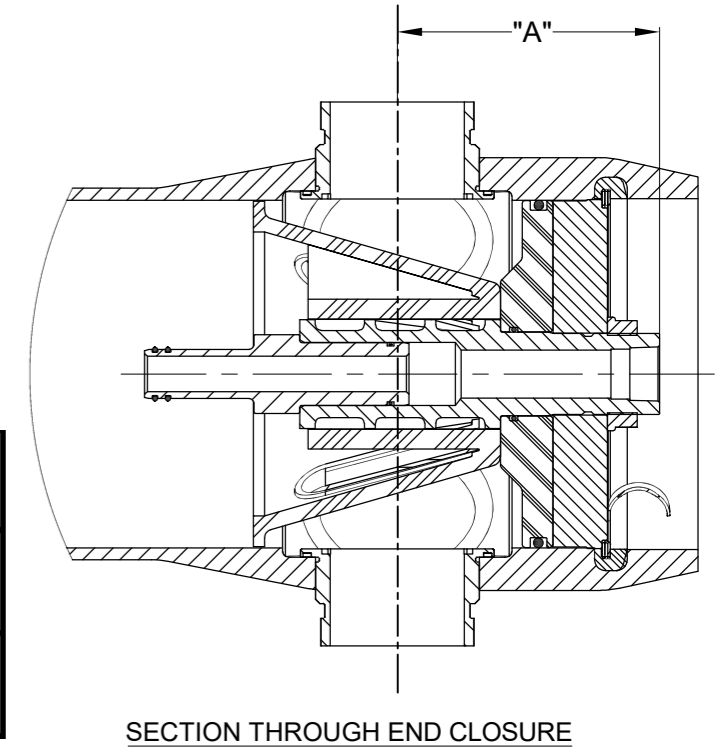

F/C PORT ⁺⁺ & SEAL PART NUMBER			
SIZE	***CD3MWCuN	**CE3MN	SEAL
3"	97860	97996	196141
2.5"	97859	97999	196226
2.0"	97858	97998	196225
1.5"	97857	97997	196224

PERM PORT RETAINER RING & PORT NUT PART NUMBERS			
1.0" / 1.25"	Standard Port nut	Engineering Thermoplastic	45066
1.5"	Port Retainer Ring	Stainless Steel	45247

PERMEATE PORT PART NUMBERS & PERMPORT TO F/C PORT OFFSET DISTANCE															
SIZE	MATERIAL	FNPT		MNPT		BSPTF		BSPTM		IPS GROOVED		BSPPF		BSPPM	
		PART NUMBER	DIM "A"	PART NUMBER	DIM "A"	PART NUMBER	DIM "A"	PART NUMBER	DIM "A"	PART NUMBER	DIM "A"	PART NUMBER	DIM "A"	PART NUMBER	DIM "A"
1.0"	NORYL	96161	6.0	97378	7.0	97664	6.0	97384	7.0	97689	7.3	96771	6.0	196822	7.0
	SS 316L # #	97247	6.0	97379	7.0	97382	6.0	97385	7.0	97388	7.3	NA	NA	NA	NA
	#ZERON 100	97295	6.0	97380	7.0	97383	6.0	97386	7.0	97389	7.3	NA	NA	NA	NA
1.25"	NORYL	NA	NA	97665	7.0	NA	NA	97666	7.0	97667	7.3	NA	NA	NA	NA
	SS 316L # #	NA	NA	97390	7.0	NA	NA	97392	7.0	97167	7.3	NA	NA	NA	NA
	#ZERON 100	NA	NA	97391	7.0	NA	NA	97393	7.0	97395	7.3	NA	NA	NA	NA
1.5"	NORYL	NA	NA	97668	6.6	NA	NA	97399	6.6	97669	7.2	NA	NA	NA	NA
	SS 316L # #	NA	NA	97397	6.6	NA	NA	97400	6.6	97448	7.2	NA	NA	NA	NA
	#ZERON 100	NA	NA	97398	6.6	NA	NA	97401	6.6	97403	7.2	NA	NA	NA	NA

GENERAL NOTES:

- DIMENSIONS IN INCHES (MM APPROX.).
- ** GRADE SA-995 CE3MN (UNS J93404). CE3MN CANNOT BE OFFERED FOR ASME STAMPED VESSELS.
- *** GRADE SA-995 CD3MWCuN (UNS J93380)
- # GRADE SA-479 UNS S32760/S32750
- ## GRADE SA-479 316L
- ### GRADE SA-182 F316L
- + OPTIONAL STRAP ASSEMBLY WITH SS-316 & 316L SHALL BE SUPPLIED AS PER METRIC STANDARDS.
- ++ ASME PARTS.

THIS DOCUMENT AND THE INFORMATION CONTAINED HEREIN, ARE THE CONFIDENTIAL AND PROPRIETARY INFORMATION OF PENTAIR WATER INDIA PVT. LTD. PENTAIR WATER INDIA PVT. LTD. IS THE SOLE OWNER OF THE INFORMATION AND PROCESSES DEFINED HEREIN. THIS DOCUMENT, AND THE INFORMATION CONTAINED, MAY NOT BE DISCLOSED, REPRODUCED, DUPLICATED, USED, SOLD, PUBLISHED, COMMUNICATED OR OTHERWISE DISTRIBUTED, IN WHOLE OR IN PART, FOR ANY PURPOSE WITHOUT THE EXPRESS WRITTEN CONSENT OF PENTAIR WATER INDIA PVT. LTD. THIS DOCUMENT AND ANY COPIES, IN ALL APPLICABLE FORMATS, SHALL BE RETURNED TO PENTAIR WATER INDIA PVT. LTD. UPON REQUEST.

ALL INDICATED PENTAIR TRADEMARKS AND LOGOS ARE PROPERTY OF PENTAIR. THIRD PARTY REGISTERED AND UNREGISTERED TRADEMARKS AND LOGOS ARE PROPERTY OF THEIR RESPECTIVE OWNERS. BECAUSE WE ARE CONTINUOUSLY IMPROVING OUR PRODUCTS AND SERVICES, PENTAIR RESERVES THE RIGHT TO CHANGE SPECIFICATIONS WITHOUT PRIOR NOTICE. PENTAIR IS AN EQUAL OPPORTUNITY EMPLOYER.

© 2021 Pentair. All Rights Reserved.



DRAWN BY:	PGS	DRAWING DESCRIPTION:	DRAWING NO.:	REV.:
DATE:	27JAN06	MODEL - 80H120 MEMBRANE HOUSING	99170	AJ
CHECKED BY:	MD	CUSTOMER NAME:	VESSEL MODEL:	
DATE:	27JAN06	-	80H120	
APPROVED BY:	RM	PROJECT NAME:	TOTAL QTY:	
DATE:	27JAN06	-	-	
PCO NO.:	548441	CUSTOMER P.O.#:	SIZE:	SCALE:
REV. DATE:	17OCT25	-	A3	NONE
				PAGE NO.:
				03 OF 03