



EVERPURE® A-20 20" OPAQUE HOUSING

OPAQUE FILTER HOUSING

A-20 20" Clear Housing: EV9100-03



APPLICATIONS

Foodservice

FEATURES • BENEFITS

- 20" utility housing
- Clear bowl with mounting bracket
- Holds any 20" drop-in filter or softening cartridge
- Versatile basic design accommodates many applications

INSTALLATION TIPS

- Install vertically so bowls hang down.
- Allow 2-1/2" (63.5mm) clearance below the cartridge for easy cartridge replacement.
- Make sure o-ring on bowl is sufficiently lubricated.
- Always screw on bowls by hand. Do not use a housing wrench.

OPERATION TIPS

- Change cartridges on a regular six (6) month preventative maintenance program.
- Change cartridges according to cartridge specifications.

SIZING

Service Flow Rate: Maximum 5 gpm (19 Lpm)

EVERPURE® A-20 20" OPAQUE HOUSING

EV9100-03

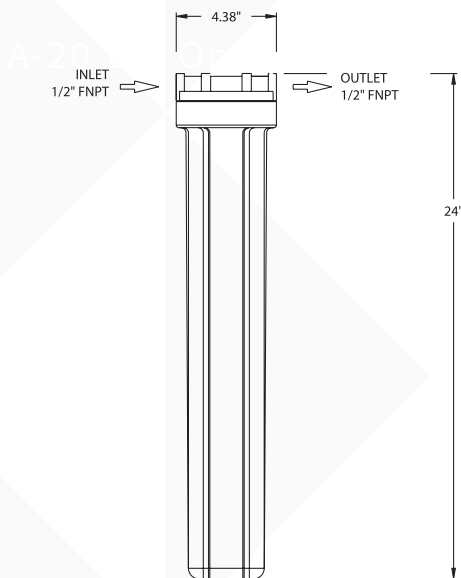

SPECIFICATIONS

Service Flow Rate

Maximum 5 gpm (19 Lpm)

Pressure Requirements

10 - 125 psi (0.7 - 8.6 bar), non-shock

Overall Dimensions

24" H x 4.38" W x 4.38" D
(60.9 x 11.1 x 11.1 cm)

Connections

Inlet Connection: 1/2"

Outlet Connection: 1/2"

Temperature

35 - 100°F (2 - 38°C)

Shipping Weight

5 lbs (2.3 kgs)

Operating Weight

6 lbs (2.7 kgs)

Electrical Connection

None required

The contaminants or other substances removed or reduced by this drinking water system are not necessarily in your water. Do not use with water that is microbiologically unsafe or of unknown quality without adequate disinfection before or after the system. Systems certified for cyst reduction may be used with disinfected water that may contain filterable cysts.

WARRANTY

Everpure water treatment systems by Pentair® (excluding replaceable elements) are covered by a limited warranty against defects in material and workmanship for a period of five years after date of purchase. Everpure replaceable elements (filter cartridges and water treatment cartridges) are covered by a limited warranty against defects in material and workmanship for a period of one year after date of purchase. See printed warranty for details. Pentair will provide a copy of the warranty upon request.



FILTRATION & PROCESSING SOLUTIONS

EVERPURE-SHURFLO WORLD HEADQUARTERS, 1040 MUIRFIELD DRIVE, HANOVER PARK, IL 60133 USA • WWW.EVERPURE.COM
800.942.1153 MAIN (US ONLY) • 630.307.3000 MAIN • 630.307.3030 FAX • CSEVERPURE@PENTAIR.COM EMAIL

EVERPURE-SHURFLO AUSTRALIA, 1-21 MONASH DRIVE, DANDENONG SOUTH, VIC 3175, AUSTRALIA
011.1300.576.190 TEL • 011.61.39.562.7237 FAX • AU.EVERPURE@PENTAIR.COM EMAIL

EVERPURE-SHURFLO CHINA, 21F CLOUD 9 PLAZA, NO 1118, SHANGHAI, 200052, CHINA
86.21.3211.4588 TEL • 86.21.3211.4580 FAX • CHINA.WATER@PENTAIR.COM EMAIL

EVERPURE-SHURFLO INDIA, GREEN BOULEVARD, B-9/A, 7TH FLOOR - TOWER B SECTOR 62, NOIDA - 201301
91.120.419.9444 TEL • 91.120.419.9400 FAX • INDIACUSTOMER@PENTAIR.COM EMAIL

EVERPURE-SHURFLO EUROPE, PENTAIR WATER BELGIUM BVBA, INDUSTRIEPARK WOLFSTEE, TOEKOMSTLAAN, 30 B-2200 HERENTALS, BELGIUM
+32.(0).14.283.500 TEL • +32.(0).14.283.505 FAX • SALES@EVERPURE-EUROPE.COM EMAIL

EVERPURE-SHURFLO JAPAN INC., HASHIMOTO MN BLDG. 7F, 3-25-1 HASHIMOTO, MIDORI-KU, SAGAMIHARA-SHI KANAGAWA 252-0143, JAPAN
81.(0)42.775.3011 TEL • 81.(0)42.775.3015 FAX • INFO@EVERPURE.CO.JP EMAIL

EVERPURE-SHURFLO SOUTHEAST ASIA, SOUTHEAST ASIA, 390 HAVELOCK ROAD, #04-01, KING'S CENTRE, SINGAPORE 169662
65.6768.5800 TEL • 65.6737.5149 FAX • CSEVERPURE@PENTAIR.COM EMAIL

All Pentair trademarks and logos are owned by Pentair, Inc. or its affiliates. All other registered and unregistered trademarks and logos are the property of their respective owners. Because we are continuously improving our products and services, Pentair reserves the right to change specifications without prior notice. Pentair is an equal opportunity employer.