



# EVERPURE® WS-30E SERIES WATER CONDITIONERS

SINGLE TANK SYSTEM FOR COMMERCIAL AND LIGHT INDUSTRIAL APPLICATIONS

WS-30E (120 VAC 50/60 Hz): EV9980-58  
WS-30E (230 VAC 50 Hz): EV9980-59



## APPLICATIONS

Reverse Osmosis Pretreatment  
Espresso  
Warewashing  
Laundry - Linen and Uniform

Boiler Scale Control  
Water Heater Scale Protection/Reduction  
General Housekeeping

## FEATURES • BENEFITS

Hardness removal of 30,000 grains at flow rates up to 10 gpm (37.8 Lpm) continuous

Advanced, user-friendly controls incorporate time-tested, hydraulically-balanced piston, seal and spacer design to pilot service flow and regeneration

Fleck® 5600-SXT meter-initiated control valve monitors water usage and minimizes salt, water and electrical costs

Five-cycle control delivers controlled upflow backwash, downflow brining and slow rinse, rapid rinse, timed brine refill and downflow service

Fiberglass-reinforced resin vessels with NSF® approved polyethylene liners eliminate worries about corrosion

Single tank design for simplicity, economy and space savings

Large capacity brine tank maximizes time between salt replenishments

## INSTALLATION TIPS

Locate equipment on a smooth, level surface.

Maintain an air-gap at the end of the drain line.

Secure drain line directly over floor drain or stand pipe.

When connecting to a water heater, install a check valve on the soft water piping to prevent hot water backup.

Protect the control valve from excessive heat when sweating/installing copper piping.

Check local codes for additional equipment that may be required, such as backflow prevention devices (i.e., RPZ valve).

## OPERATION TIPS

Check for softened water each time salt is added by using a soap or hardness test kit.

Use a good quality grade of salt - solar crystal or pellet salt is preferred.

Check the salt level on a regular basis.

Maintain a minimum salt depth of six (6) inches to ensure a proper regeneration.

On iron-bearing waters, use a salt that contains an iron-fighting additive, or use a resin cleaner on a regular basis.

If water level in the brine tank is abnormally high, refer to IO Guide for troubleshooting information.

## SIZING

Service Flow Rate: @ 15 psi (1.0 bar) ΔP  
Continuous: 10 gpm (37.8 Lpm)  
Peak: 15 gpm (56.8 Lpm)

Rated Capacity:  
30,000 grains @ 15 lbs (6.8 kg) salt  
24,000 grains @ 10 lbs (4.1 kg) salt  
20,000 grains @ 6 lbs (2.7 kg) salt

# EVERPURE® WS-30E SERIES WATER CONDITIONERS

EV9980-58 • EV9980-59

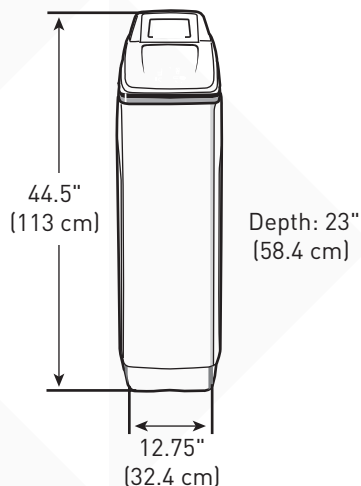

## SPECIFICATIONS

### Rated Capacity

30,000 grains @ 15 lbs (6.8 kg) salt  
24,000 grains @ 10 lbs (4.1 kg) salt  
20,000 grains @ 6 lbs (2.7 kg) salt

### Salt Storage Capacity

225 lbs (102.1 kgs)

### Pressure Requirements

25 - 100 psi (1.7 - 6.9 bar) non-shock

### Temperature Requirements

35 - 100°F (1.7 - 38°C)

### Overall Dimensions

12.75" W x 23" D x 44.5" H  
(32.4 cm x 58.4 cm x 113 cm)

### Service Flow Rate @ 15 psi (1.0 bar) ΔP

Continuous: 10 gpm (37.8 Lpm)  
Peak: 15 gpm (56.8 Lpm)

### Inlet and Outlet Connections

3/4" MNPT

### Drain Line Connections

1/2" FNPT

### Electrical

120 VAC 50/60 Hz - NEMA 1-15P (EV9980-58)  
230 VAC 50 Hz - CEE 7/16 "Schuko" (EV9980-59)

### Shipping Weight

90 lbs (40.8 kgs)

### Operating Weight

550 lbs (249.5 kgs)



## WATER QUALITY SYSTEMS

EVERPURE-SHURFLO WORLD HEADQUARTERS, 1040 MUIRFIELD DRIVE, HANOVER PARK, IL 60133 USA • FOODSERVICE.PENTAIR.COM  
800.942.1153 MAIN (US ONLY) • 630.307.3000 MAIN • 630.307.3030 FAX • CSEVERPURE@PENTAIR.COM EMAIL

EVERPURE-SHURFLO AUSTRALIA, 1-21 MONASH DRIVE, DANDENONG SOUTH, VIC 3175, AUSTRALIA  
011.1300.576.190 TEL • 011.61.39.562.7237 FAX • AU.EVERPURE@PENTAIR.COM EMAIL

EVERPURE-SHURFLO CHINA, 21F CLOUD 9 PLAZA, NO 1118, SHANGHAI, 200052, CHINA  
86.21.3211.4588 TEL • 86.21.3211.4580 FAX • CHINA.WATER@PENTAIR.COM EMAIL

EVERPURE-SHURFLO INDIA, GREEN BOULEVARD, B-9/A, 7TH FLOOR - TOWER B SECTOR 62, NOIDA - 201301  
91.120.419.9444 TEL • 91.120.419.9400 FAX • INDIACUSTOMER@PENTAIR.COM EMAIL

EVERPURE-SHURFLO EUROPE, PENTAIR WATER BELGIUM BVBA, INDUSTRIEPARK WOLFSTEE, TOEKOMSTLAAN, 30 B-2200 HERENTALS, BELGIUM  
+32.(0).14.283.500 TEL • +32.(0).14.283.505 FAX • SALES@EVERPURE-EUROPE.COM EMAIL

EVERPURE-SHURFLO JAPAN INC., HASHIMOTO MN BLDG. 7F, 3-25-1 HASHIMOTO, MIDORI-KU, SAGAMIHARA-SHI KANAGAWA 252-0143, JAPAN  
81.(0)42.775.3011 TEL • 81.(0)42.775.3015 FAX • INFO@EVERPURE.CO.JP EMAIL

EVERPURE-SHURFLO SOUTHEAST ASIA, SOUTHEAST ASIA, 390 HAVELOCK ROAD, #04-01, KING'S CENTRE, SINGAPORE 169662  
65.6768.5800 TEL • 65.6737.5149 FAX • CSEVERPURE@PENTAIR.COM EMAIL

All Pentair trademarks and logos are owned by Pentair, Inc. or its affiliates. All other registered and unregistered trademarks and logos are the property of their respective owners. Because we are continuously improving our products and services, Pentair reserves the right to change specifications without prior notice. Pentair is an equal opportunity employer.

## WARRANTY

Everpure water softening systems by Pentair® are covered by a limited warranty against defects in material and workmanship for the following periods:

- Complete System - 1 year
- Control Valve - 5 years
- Mineral Tank(s) -
  - 6-13" diameter - 10 years
  - 14" diameter and larger - 5 years

See printed warranty for details. Pentair will provide a copy of the warranty upon request.