



EVERPURE® CONSERV® 75S HIGH EFFICIENCY REVERSE OSMOSIS SYSTEM

FOR LOW VOLUME STEAM APPLICATIONS

EV9976-00 Conserv 75S RO System - US
EV9976-01 Conserv 75S RO System - EU
EV9976-02 Conserv 75S RO System - UK
EV9976-03 Conserv 75S RO System - AU
EV9693-21 4FC5 Pretreatment Carbon Cartridge
4002575 Pentair GRO-75EN RO Membrane Cartridge
EV9627-45 4CC Post Treatment Calcite Feeder
EV9976-25 Conserv 75S Cartridge Kit (GRO-75EN Cartridge, 4CC Calcite Feeder and 4FC5 Cartridge)



APPLICATIONS

Combi-Ovens <3 gph
Small Steamers

Proofers
Low Volume Applications
up to 50 gpd (189 Lpd)

FEATURES • BENEFITS

High efficiency reverse osmosis system for combi-ovens and small steamers

System includes 4FC5 Pretreatment Carbon Filter, High Efficiency GRO-75EN RO Membrane Cartridge, onboard RO water storage tank, 4CC Post Treatment Calcite Feeder and blending valve to balance effluent water mineral content

Improves equipment life and performance by removing 95%+ of all dissolved solids that may cause corrosion and scale buildup

Up to 50% water savings over conventional RO systems

Especially useful on direct injection combi-ovens producing less than 3 gallons per hour (gph)

Proprietary Fibredyne™ II filtration media effectively inhibits the growth of bacteria on the filter media that can decrease product life.

Less frequent deliming of equipment means reduced maintenance and service costs

Heating surfaces maintain peak heat transfer efficiency, reducing cycle times and energy consumption

Compact design allows for wall mount, countertop or undercounter installation

Protects against taste- and odor-causing contaminants while removing dirt, particulates and dissolved minerals

Sanitary cartridge replacement is simple, quick and clean; internal filter parts are never exposed to handling or contamination

NSF/ANSI Standard 58 certified to reduce cysts such as *Cryptosporidium* and *Giardia* by mechanical means

INSTALLATION TIPS

Choose a mounting location suitable to support the full weight of the system when operating.

Install vertically with cartridges hanging down.

Allow 2½" (6.35 cm) clearance below the cartridge for easy cartridge replacement.

The water inlet must supply a minimum of 40-85 psi (2.7-5.8 bar), non-shock.

Delime equipment prior to installation.

OPERATION TIPS

Replace the Everpure 4FC5 Pretreatment Carbon Filter Cartridge, the Everpure 4CC Post Treatment Calcite Feeder and the Pentair GRO-75EN RO Membrane Cartridge every 12 months.

SIZING

Daily Production Rate:
50.51 gpd (191.20 Lpd)

EVERPURE® CONSERV® 75S HIGH EFFICIENCY REVERSE OSMOSIS SYSTEM

EV9976-00 • EV9976-01 • EV9976-02 • EV9976-03

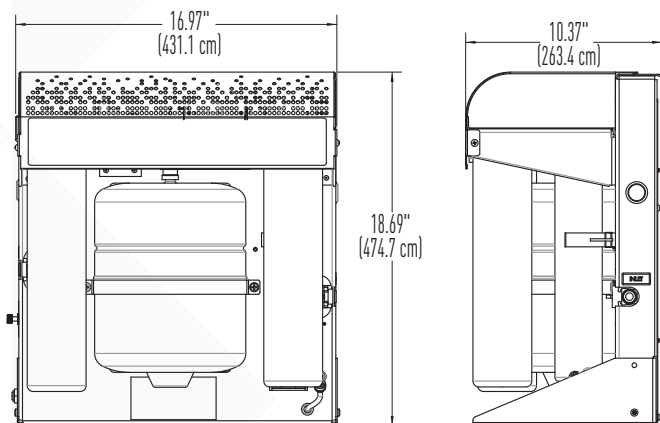

The contaminants or other substances removed or reduced by this drinking water system are not necessarily in your water. Do not use with water that is microbiologically unsafe or of unknown quality without adequate disinfection before or after the system. Systems certified for cyst reduction may be used with disinfected water that may contain filterable cysts.

WARRANTY

Everpure Conserv 75S Reverse Osmosis System by Pentair (excluding replaceable elements) are covered by a limited warranty against defects in material and workmanship for a period of one year after the date of purchase.

Everpure replaceable elements by Pentair (filter cartridges and water treatment cartridges) are covered by a limited warranty against defects in material and workmanship for a period of one year after date of purchase. See printed warranty for details. Pentair will provide a copy of the warranty upon request.

EPA Est. No. 002623-IL-002
EPA Est. No. 082989-CHN-001

SPECIFICATIONS

Daily Production Rate
50.51 gpd (191.20 Lpd)

Service Flow Rate
0.5 gpm @ 50–85 psi
(1.9 L @ 3.4–5.8 bar)

Overall Dimensions
18.69" H x 16.97" W x 10.37" D
(47.5 cm x 43.1 cm x 26 cm)

Inlet Connection
3/8" OD John Guest® fitting

Outlet Connection
3/8" OD John Guest fitting

Wastewater Line Connection
1/4" OD John Guest fitting

Operating Pressure Requirements
40–85 psi (2.7–5.8 bar), non-shock

Maximum Operating Pressure
125 PSI (8.6 bar)

Inlet Temperature
32–100°F (0–37.7°C)

Inlet TDS
1,000 ppm maximum

Operating Weight
53 lbs (24.04 kgs)

Wastewater Production
14–20 gpd @ 60 psig, 77°F
(53–75 Lpd @ 414 kPa, 25°C)

Wastewater Drain Line Capacity
0.05 gpm (200 ml/m) to open atmosphere

Storage Tank Capacity
2 gallon tank; effective/usable capacity
1 gallon (3.8 L)

Electrical
100–240VAC/50–60Hz
switchable power supply



The RO System is Tested and Certified by NSF International against NSF/ANSI Standard 58 for the reduction of the claims specified on the Performance Data Sheet or at www.nsf.org.



WATER FILTRATION

EVERPURE-SHURFLO WORLD HEADQUARTERS, 1040 MUIRFIELD DRIVE, HANOVER PARK, IL 60133 USA • FOODSERVICE.PENTAIR.COM
800.942.1153 (US ONLY) • 630.307.3000 MAIN • 630.307.3030 FAX • CSEVERPURE@PENTAIR.COM EMAIL

EVERPURE-SHURFLO AUSTRALIA, 1-21 MONASH DRIVE, DANDENONG SOUTH, VIC 3175 AUSTRALIA
011.1300 576 190 TEL • 011.61.39.562.7237 FAX • AU.EVERPURE@PENTAIR.COM EMAIL

EVERPURE-SHURFLO CHINA, 21F CLOUD 9 PLAZA, NO 1118, SHANGHAI, 200052, CHINA
86.21.3211.4588 TEL • 86.21.3211.4580 FAX • CHINA.WATER@PENTAIR.COM EMAIL

EVERPURE-SHURFLO INDIA, GREEN BOULEVARD, B-9/A, 7TH FLOOR - TOWER B SECTOR 62, NOIDA - 201301
91.120.419.9444 TEL • 91.120.419.9400 FAX • INDIACUSTOMER@PENTAIR.COM EMAIL

EVERPURE-SHURFLO EUROPE, PENTAIR WATER BELGIUM BVBA, INDUSTRIEPARK WOLFSTEE, TOEKOMSTLAAN 30, B-2200 HERENTALS, BELGIUM
+32.(0).14.283.504 TEL • +32.(0).14.283.505 FAX • SALES@EVERPURE-EUROPE.COM EMAIL

EVERPURE-SHURFLO JAPAN INC., HASHIMOTO MN BLDG. 7F, 3-25-1 HASHIMOTO, MIDORI-KU, SAGAMIHARA-SHI KANAGAWA 252-0143, JAPAN
81.(0)42.775.3011 TEL • 81.(0)42.775.3015 FAX • INFO@EVERPURE.CO.JP EMAIL

EVERPURE-SHURFLO SOUTHEAST ASIA, 390 HAVELOCK ROAD, #04-01 KING'S CENTRE, SINGAPORE 169662
65.6768.5800 TEL • 65.6737.5149 FAX • CSEVERPURE@PENTAIR.COM EMAIL

Pentair trademarks and logos are owned by Pentair plc or its affiliates. Third party registered and unregistered trademarks and logos are property of their respective owners. Because we are continuously improving our products and services, Pentair reserves the right to change specifications without prior notice. Pentair is an equal opportunity employer.