

SHURFLO® WATER BOOST AND LVPO FILTRATION

TWO (2) GALLON WATER BOOST AND INTEGRATED LVPO F1 FILTRATION

WB2-LVPO-01
 94-399-00 LVPO F1 Replacement Filter
 94-471-00 Quick Connect 3/8" Barb Ball Valve
 94-471-01 Quick Connect 1/2" NPT
 94-475-00 LVPO Filter QD Bypass
 94-472-00 Filter Bracket For Tank Mount



APPLICATIONS

Fountain
 Ice

FEATURES • BENEFITS

Compact design provides boosted filtered water to the fountain system and treated non-boosted water to the ice machine

Specifically designed for low syrup volume accounts

Proprietary filter media with gradient depth and radial flow design resulting in maximized filter life

Eliminates carbon fine buildup in soda valves

Improved water quality for great tasting beverages

Everpure® LVPO-F1 Filter 5.0 micron carbon block media for chlorine taste & odor reduction

Low pressure drop of less than 8 psi at 3.0 gpm (0.55 bar at 11.4 Lpm) - helps keep consistent Brix ratio

SHURlock Quick-Connect fittings

INSTALLATION TIPS

Check precharge at time of installation is at 50 psi (3.4 bar).

Check tank precharge each service visit to ensure optimum performance.

Do not charge accumulator tank with CO₂.

OPERATION TIPS

SIZING

High Flow Rate: supports 150 - 200+ gpd (568 - 757 Lpd) systems at standard recovery rates

Pressures: up to 140 psi (9.6 bar)

SHURFLO® WATER BOOST AND LVPO FILTRATION

WB2-LVPO-01

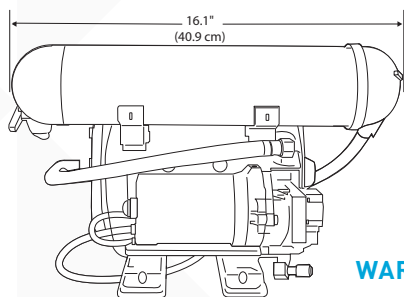
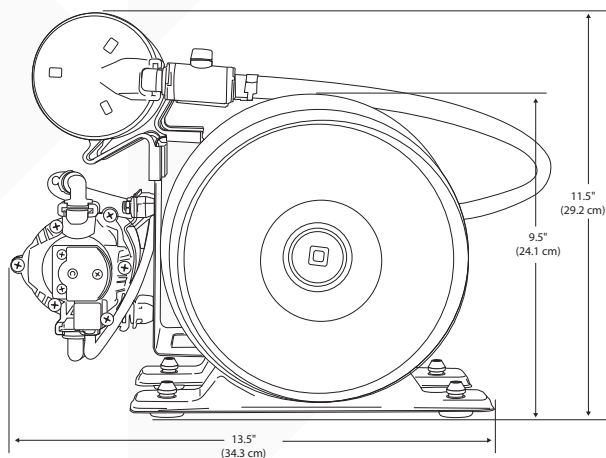

SPECIFICATIONS

Booster Pump

SHURflo 90 psi (6.2 bar) 115 VAC 8000 series corded pump (NSF listed)

Accumulator Tank

2 gallon (7.5 L) SS (NSF listed)

Filtration

LVPO-F1 Filter 5.0 micron carbon block media for chlorine taste & odor reduction

Water Ports

3/8" barb inlet/outlet

Pre-charge

50 psi (3.4 bar) (recommended for most beverage applications)

Draw Down Volume

0.75 gallon @50 psi pre-charge
(2.8 L @ 3.4 bar)

Dimensions

13.5" H x 14" W x 17" D
(34.3 x 35.6 x 43.1 cm)

Weight

18 pounds (8.1 kg) (empty)

WARRANTY

Limited Pentair® Warranty is valid from the date of manufacture or with proof of purchase:

2088 - One year
Water Boost - One year
Water Pressure Reducer Valve - One year
8000, 8025, 8010, 8075, 8095 - One year

Pentair will provide a copy of the warranty upon request.



FILTRATION & PROCESSING SOLUTIONS

EVERPURE-SHURFLO WORLD HEADQUARTERS, 1040 MUIRFIELD DRIVE, HANOVER PARK, IL 60133 USA • WWW.EVERPURE.COM
800.942.1153 MAIN (US ONLY) • 630.307.3000 MAIN • 630.307.3030 FAX • CSEVERPURE@PENTAIR.COM EMAIL

EVERPURE-SHURFLO AUSTRALIA / NEW ZEALAND, 1-21 MONASH DRIVE, DANDENONG SOUTH, VIC, 3175, AUSTRALIA
1300.576.190 TEL • AU.EVERPURE@PENTAIR.COM EMAIL

EVERPURE-SHURFLO CHINA, 21F CLOUD 9 PLAZA, NO 1118, SHANGHAI, 200052, CHINA
86.21.3211.4588 TEL • 86.21.3211.4580 FAX • CHINA.WATER@PENTAIR.COM EMAIL

EVERPURE-SHURFLO INDIA, GREEN BOULEVARD, B-9/A, 7TH FLOOR - TOWER B SECTOR 62, NOIDA - 201301
91.120.419.9444 TEL • 91.120.419.9400 FAX • INDIACUSTOMER@PENTAIR.COM EMAIL

EVERPURE-SHURFLO EUROPE, PENTAIR WATER BELGIUM BVBA, INDUSTRIEPARK WOLFSTEE, TOEKOMSTLAAN, 30 B-2200 HERENTALS, BELGIUM
+32.(0).14.283.500 TEL • +32.(0).14.283.505 FAX • SALES@EVERPURE-EUROPE.COM EMAIL

EVERPURE-SHURFLO JAPAN INC., HASHIMOTO MN BLDG. 7F, 3-25-1 HASHIMOTO, MIDORI-KU, SAGAMIHARA-SHI KANAGAWA 252-0143, JAPAN
81.(0)42.775.3011 TEL • 81.(0)42.775.3015 FAX • INFO@EVERPURE.CO.JP EMAIL

EVERPURE-SHURFLO SOUTHEAST ASIA, 390 HAVELOCK ROAD, #04-01, KING'S CENTRE, SINGAPORE 169662
65.6795.2213 TEL • FAX: 65.6795.2219 FAX • CSEVERPURE@PENTAIR.COM EMAIL

All Pentair trademarks and logos are owned by Pentair, Inc. All other brand or product names are trademarks or registered marks of their respective owners. Because we are continuously improving our products and services, Pentair reserves the right to change specifications without prior notice. Pentair is an equal opportunity employer.