

# EVERPURE® CGS-12 10" DUAL SERIES HOUSING

FOODSERVICE SYSTEM HOUSING FOR DROP-IN CARTRIDGES

CGS-12 10" Single Housing: EV9100-12



## APPLICATIONS

Foodservice

## FEATURES • BENEFITS

10" low profile Slim Line dual bowl housing in series configuration

Manufactured of durable polypropylene

System includes water pressure gauge

Includes wall mounting bracket and hardware for fast and easy installation

System is shipped fully assembled

Choose the appropriate cartridge for your needs

Cartridge sold separately

Bowl housing assembly accepts drop-in cartridges

Has excellent chemical resistance

Equipped with a pressure relief button to relieve water pressure during cartridge changes

## INSTALLATION TIPS

Choose a mounting location suitable to support the full weight of the system when operating

Install vertically so bowl hangs down

Allow 2-1/2" (6.35 cm) clearance below the cartridge for easy cartridge replacement

Make sure o-ring on bowl is sufficiently lubricated

Always screw on bowls by hand; do not use a housing wrench

Flush filter by running water through filter according to cartridge instructions

## OPERATION TIPS

Change cartridges on a regular six (6) month preventative maintenance program

Change cartridges when capacity is reached or when pressure decreases

Always inspect o-ring; change and/or lubricate if necessary

Clean bowl with mild solution of detergent before inserting new cartridge

Always flush the filter cartridge at time of installation and cartridge change

## SIZING

Service Flow Rate:  
Maximum 4 gpm (15.1 Lpm)

# EVERPURE® CGS-12 10" DUAL SERIES HOUSING

## EV9100-12

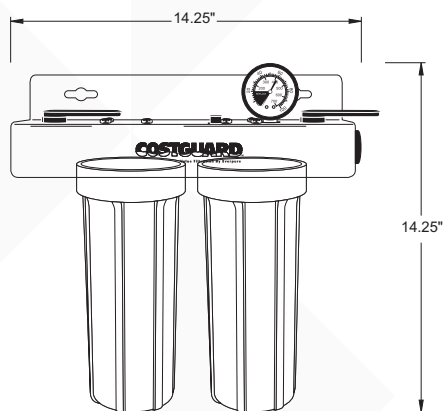

### SPECIFICATIONS

#### Overall Dimensions

14.25" H x 14.25" W x 5.25" D  
(36.1 x 36.1 x 13.3 cm)

#### Connections

Inlet Connection: 1/2"

Outlet Connection: 1/2"

#### Service Flow Rate

Maximum 4 gpm (15.1 Lpm)

#### Pressure Requirements

30 - 125 psi (2.1 - 8.6 bar), non-shock

#### Temperature

40 - 100°F (4.4 - 38°C)

#### Electrical Connection:

None required

The contaminants or other substances removed or reduced by this drinking water system are not necessarily in your water. Do not use with water that is microbiologically unsafe or of unknown quality without adequate disinfection before or after the system. Systems certified for cyst reduction may be used with disinfected water that may contain filterable cysts.

### WARRANTY

Everpure water treatment systems by Pentair® (excluding replaceable elements) are covered by a limited warranty against defects in material and workmanship for a period of five years after date of purchase. Everpure replaceable elements (filter cartridges and water treatment cartridges) are covered by a limited warranty against defects in material and workmanship for a period of one year after date of purchase. See printed warranty for details. Pentair will provide a copy of the warranty upon request.



#### FILTRATION & PROCESSING SOLUTIONS

EVERPURE-SHURFLO WORLD HEADQUARTERS, 1040 MUIRFIELD DRIVE, HANOVER PARK, IL 60133 USA • WWW.EVERPURE.COM  
800.942.1153 MAIN (US ONLY) • 630.307.3000 MAIN • 630.307.3030 FAX • CSEVERPURE@PENTAIR.COM EMAIL

EVERPURE-SHURFLO AUSTRALIA / NEW ZEALAND, 1-21 MONASH DRIVE, DANDENONG SOUTH, VIC, 3175, AUSTRALIA  
1300.576.190 TEL • AU.EVERPURE@PENTAIR.COM EMAIL

EVERPURE-SHURFLO CHINA, 21F CLOUD 9 PLAZA, NO 1118, SHANGHAI, 200052, CHINA  
86.21.3211.4588 TEL • 86.21.3211.4580 FAX • CHINA.WATER@PENTAIR.COM EMAIL

EVERPURE-SHURFLO INDIA, GREEN BOULEVARD, B-9/A, 7TH FLOOR - TOWER B SECTOR 62, NOIDA - 201301  
91.120.419.9444 TEL • 91.120.419.9400 FAX • INDIACUSTOMER@PENTAIR.COM EMAIL

EVERPURE-SHURFLO EUROPE, PENTAIR WATER BELGIUM BVBA, INDUSTRIEPARK WOLFSTEE, TOEKOMSTLAAN, 30 B-2200 HERENTALS, BELGIUM  
+32.(0).14.283.500 TEL • +32.(0).14.283.505 FAX • SALES@EVERPURE-EUROPE.COM EMAIL

EVERPURE-SHURFLO JAPAN INC., HASHIMOTO MN BLDG. 7F, 3-25-1 HASHIMOTO, MIDORI-KU, SAGAMIHARA-SHI KANAGAWA 252-0143, JAPAN  
81.(0)42.775.3011 TEL • 81.(0)42.775.3015 FAX • INFO@EVERPURE.CO.JP EMAIL

EVERPURE-SHURFLO SOUTHEAST ASIA, 390 HAVELOCK ROAD, #04-01, KING'S CENTRE, SINGAPORE 169662  
65.6795.2213 TEL • FAX: 65.6795.2219 FAX • CSEVERPURE@PENTAIR.COM EMAIL

All Pentair trademarks and logos are owned by Pentair, Inc. All other brand or product names are trademarks or registered marks of their respective owners. Because we are continuously improving our products and services, Pentair reserves the right to change specifications without prior notice. Pentair is an equal opportunity employer.