



**AURORA<sup>®</sup>**

# MODELS 361A, 362A AND 364A **END SUCTION PUMPS**

## **INSTRUCTION AND REPAIR MANUAL**

NOTE! To the installer: Please make sure you provide this manual to the owner of the equipment or to the responsible party who maintains the system.

**THIS PAGE INTENTIONALLY LEFT BLANK**

**CALIFORNIA PROPOSITION 65 WARNING:**

 **Warning:** This product and related accessories contain chemicals known to the State of California to cause cancer, birth defects or other reproductive harm.

**NOTE**

This repair manual is applicable to pump Models 361A, 362A and 364A. All photos illustrate Model 364A.

**ATTENTION: SAFETY WARNINGS:**

Read and understand all warnings before installation or servicing pump.

**OPERATIONAL LIMITS: \***

Maximum Operating Pressure: 175 psi at Temperatures to 150°F (65.6°C)  
Maximum Operating Temperature: 225°F (107°C)

\* See ASTM A126/ANSI B16.1 for pressure/temperature ratings of flanges.

**ELECTRICAL SAFETY:**

 **Warning:** Electrical Shock Hazard

All electrical connections are to be made by a qualified electrician in accordance with all codes and ordinances. Failure to follow these instructions could result in serious personal injury, death or property damage.

 **Warning:** Electrical Overload Hazard

Insure all motors have properly sized overload protection. Failure to follow these instructions could result in serious personal injury, death or property damage.

 **Warning:** Sudden Start-Up Hazard

Disconnect and lockout power source before servicing. Failure to follow these instructions could result in serious personal injury, death or property damage.

**HIGH TEMPERATURE SAFETY:**

 **Warning:** Hot Surface Hazard

If pumping hot water, insure guards or proper insulation is installed to protect against skin contact to hot piping or pump components. Failure to follow these instructions could result in serious personal injury, death or property damage.

 **Warning:** Spraying Water Hazard

When servicing pump replace all gaskets and seals. Do not re-use old gaskets or seals. Failure to follow these instructions could result in serious personal injury, death or property damage.

**HIGH PRESSURE SAFETY:**

 **Warning:** High Pressure Hazard

The pump is rated at a maximum of 175 psi at 150°F. Do not exceed this pressure. Install properly sized pressure relief valves in system. Failure to follow these instructions could result in serious personal injury, death or property damage.

 **Warning:** Expansion Hazard

Water expands when heated. Install properly sized thermal expansion tanks and relief valves. Failure to follow these instructions could result in serious personal injury, death or property damage.

**SERVICE**

Your Aurora pump requires no maintenance other than periodic inspection, occasional cleaning and lubrication of bearings (Model 364A only). The intent of inspection is to prevent breakdown, thus obtaining optimum service life. The liquid end of the pump is lubricated by the fluid being pumped and therefore does not require periodic lubrication. The motor, however may require lubrication, in which case, the motor manufacturer's recommendation should be followed.

**LUBRICATION OF IMPELLER SHAFT BEARINGS**

The Model 364A pump is available with three options for lubricating the shaft bearings. They are:

1. Regreasable (standard)
2. Oil Lubrication
3. Sealed Bearings, Permanent Lubrication

Regreasable bearings will require periodic lubrication and can be accomplished by using the zerk or lubrication fittings in the cartridge cap and power frame. Lubricate the bearings at regular intervals using a grease of high quality. Polyurea base

## MODELS 361A-362A-364A

grease is recommended as lubricants for pumps operating in both wet and dry locations. Mixing of different brands of grease should be avoided due to possible chemical reactions between the brands which could damage the bearings. Accordingly, avoid grease of vegetable or animal base which can develop acids, as well as grease containing rosin, graphite, talc and other impurities. Under no circumstances should used grease be reused.

Over lubrication should be avoided as it may result in overheating and possible bearing failure. Under normal application, adequate lubrication is assured if the amount of grease is maintained at 1/3 to 1/2 the capacity of the bearing and adjacent space surrounding it.

In dry locations, each bearing will need lubrication at least every 600 hours of running time or every 6 to 12 months, whichever is more frequent. In wet locations the bearings should be lubricated at least after every 300 hours of running time or every 4 to 6 months, whichever is more frequent. A unit is considered to be installed in a wet location if the pump and motor are exposed to dripping water, to the weather, or to heavy condensation such as is found in unheated and poorly ventilated underground locations.

Oil lubricated bearings are optional on Model 364A pumps. A fixed oil level is maintained with the power frame by an oiler which allows visual indications of reserve oil.

At initial installation and before starting a unit that has been shut down for repairs or for any extended length of time, run enough 10W-30 weight motor oil through the oiler to maintain a constant oil level to insure that the bearing will never be without an oil supply. Oil will have to be added at intervals to maintain a constant level in the oiler. This interval can only be determined by experience.

Under working conditions, oil will breakdown and need to be replaced at regular intervals. The length of these intervals will depend on many factors. Under normal operation, in clean and dry locations, the oil should be changed about once a year. However, when the pump is exposed to dirt contamination, high temperatures (200°F or above) or a wet location, the oil may have to be changed every 2 to 3 months.

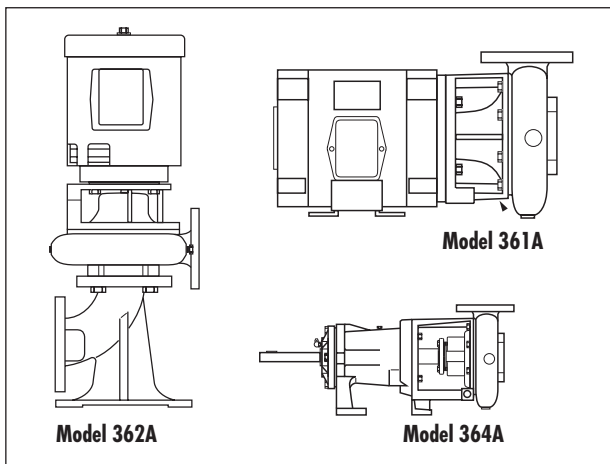

A. Assembled Units.

## CAUTION

Use normal fire caution procedures when using any petroleum cleaner.

The motor which drives your Aurora pump may or may not require lubrication. Consult the manufacturer's recommendations for proper maintenance instructions.

### REPAIRS

Before starting any work, insure the electrical power is locked out, the system pressure has been lowered to 0 psi and temperature of the unit is at a safe level.

The pump may be disassembled using the illustrations and text provided. Although complete disassembly is covered, it will seldom be necessary to completely disassemble your Aurora pump.

The illustrations accompanying the disassembly instructions show the pump at various stages of disassembly. The illustrations are intended to aid in the correct identification of the parts mentioned in the text.

Inspect removed parts at disassembly to determine if they can be reused. Ball bearings that turn roughly or show wear should be replaced. Cracked castings should never be reused. Scored or worn pump shafts should be replaced. Gaskets should be replaced at reassembly simply as a matter of economy. They are much less expensive to replace routinely than to replace singly as the need arises.

### **Warning:** Sudden Start-Up Hazard

Disconnect and lockout power source before servicing. Failure to follow these instructions could result in serious personal injury, death or property damage.

### **Warning:** Hot Surface Hazard

If pumping hot water, insure guards or proper insulation is installed to protect against skin contact to hot piping or pump components. Failure to follow these instructions could result in serious personal injury, death or property damage.

### **Warning:** High Pressure Hazard

The pump is rated at a maximum of 175 psi at 150°F. Do not exceed this pressure. Install properly sized pressure relief valves in system. Failure to follow these instructions could result in serious personal injury, death or property damage.

### **Warning:** Spraying Water Hazard

When servicing pump replace all gaskets and seals. Do not re-use old gaskets or seals. Failure to follow these instructions could result in serious personal injury, death or property damage.

## MODELS 361A-362A-364A

### DISASSEMBLY

Disassemble only what is needed to make repairs or accomplish inspection. (See Figure 2 for Model 361A, Figure 3 for Model 362A and Figure 3 for Model 364A.)

1. Disconnect and lockout power source to prevent drive unit from being energized during disassembly.
2. Unscrew the two drain plugs (4) from the casing (6). On Model 362A pumps, remove plugs (74 and 75) to drain pump. Also unscrew the two plugs (4) from casing (6).
3. Remove all relief, cooling, flushing or drain lines from pump, including compression connections (1 and 2) and tubing (3). The sealing tube assembly (optional 69, 70, 71 and 76) should be removed at this time. Break suction and discharge connections unless it is intended to remove the power frame or motor assembly and leave casing (6) in the line. On Model 362A pumps, break discharge connections only, unless it is desired to remove base (73). Remove capscrews (39) and lift pump assembly from base (73). Remove gasket (72).
4. On Model 364A pumps, remove the flexible coupling from between the pump and motor. Next unscrew the bolts that hold support(s) (41 and 64) to the base and slide the pump out to be worked on.
5. Remove capscrews (5) and pull casing (6) from bracket (35) and cover (26). Remove gasket (8).
6. Unscrew impeller screw (9) and remove washer (9A), taking care not to damage gasket (9B) or capscrew seal (9C).

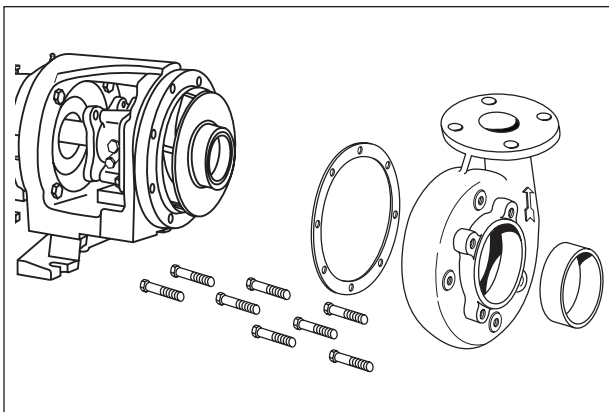

B. Casing, Gasket, and Wear Ring Removed.

7. Slide impeller (11) and impeller key (12) from the shaft, again taking care not to damage gasket (10) located behind impeller. Remove gasket (10).
8. Wear ring(s) (7 and 16) are pressed into their housings with an interface fit and must be removed with a puller. New ring(s) should be used for reassembly since it is likely that during removal this fit will be lost. Do not remove wear rings if not being replaced.
9. Impeller wear rings (optional - 14 and 15) are pressed on and must be cut off if replacement is necessary. If they are turned off in a lathe, take care not to cut into the impeller.

10. The various types of stuffing boxes may be disassembled as follows:

#### PACKING (STANDARD, WATER COOLED, AND WITH LANTERN RING)

- A. Remove adjusting nuts (21), gland clamps (22), gland halves (23) and studs (24), if used. For standard pumps remove capscrews (65).
- B. Unscrew capscrews (20), (Not required on 7" bore pumps), or (5) and remove cover assembly (26). The throat of cover (26) should be checked for excessive wear.
- C. Shaft sleeve (25) is a slip fit on the shaft and should be easily removed unless the pump has been in service for a long time. In this case it may be necessary to use a puller. Take care to prevent damaging the surface of the sleeve. Replace the sleeve if it is grooved from wear. Pin (61) may be removed from sleeve (25) if necessary.
- D. All packing (28) and lantern ring (29), (If used), must now be removed from the packing box, and the cavity thoroughly cleaned to allow new packing to fit properly.

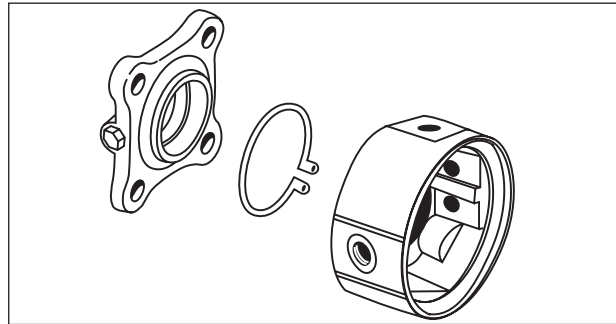

C. Water Jacket Removed.

#### MECHANICAL SEAL (OPTIONAL)

### CAUTION

The mechanical seal (see Figure 1) is a precision product and must be treated as such. During removal, great care must be taken to avoid dropping any part of the seal. Take particular care not to scratch the lapped faces on the washer or the sealing seat. If any wear of the seal faces is noted, it is recommended to replace with a new seal during reassembly.

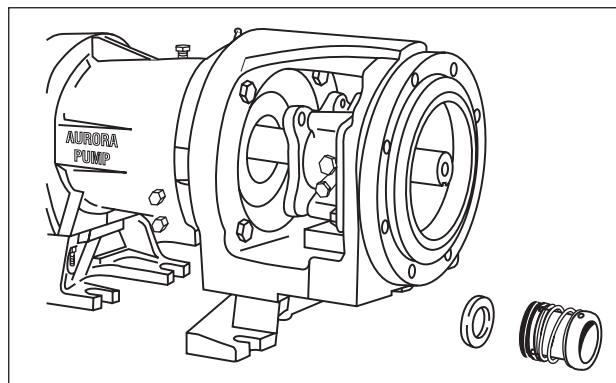

D. Mechanical Seal Removed.

## MODELS 361A-362A-364A

A. Remove capscrews (65) and slide gland (23), (Including the seal flexible cup and stationary seat), from either cover assembly (26) or water jacket (18). Take care in moving gland (23) not to damage gasket (66).

B. Unscrew capscrews (20), (Not required on 7" bore pumps), or (5) and remove cover assembly (26). The throat of cover (26) should be checked for excessive wear.

C. Slide sleeve (25) with rotating parts of mechanical seal (27) from the shaft. The sleeve should be carefully cleaned to remove any residue that may be remaining in the seal area. The rubber in the seal may have become partially adhered to the sleeve. The sleeve must also be checked for abrasion or corrosion that can occur when fluid residue penetrates between the seal (27) and sleeve (25). The sleeve under the seal may be polished lightly to a 32RMS finish before reassembly. Do not reuse a pitted sleeve. Pin (61) may be removed from the sleeve (25) if necessary.

D. Remove gland (23) and gasket (66).

E. The seal flexible cup and stationary seat should be pressed out of the gland (23) and the cavity cleaned of all residue. Make sure that the 1/32 inch radius in the seal seat cavity is not damaged during disassembly since a sharp edge can easily cut the flexible cup during reassembly.

11. The water jacket (optional - 18) may now be removed by snapping retaining ring (17) off cover (26). Note position of water jacket to assure proper alignment during reassembly. (See illustration C.) Slide water jacket (18) off cover (26) taking care not to damage gaskets (19 and 19A). Remove gaskets (19 and 19A).

12. On Model 364A pumps, remove capscrews (39 and 62) and washers (40 and 63) to take off supports (41 and 64). On Model 361A pumps frame sizes 143 thru 184 JP only. Unscrew capscrews (39) and remove washers (40), and support (41) from bracket (35).

13. Unscrew capscrews (32) to remove bracket (35) from frame (57) on Model 364A or motor on Models 361A and 362A.

14. On Model 364A pumps, remove key (42) from the shaft and remove slingers (47).

15. Unscrew capscrews (48) and remove bearing cap (49). Remove gasket (50) and retainer ring (52).

Slide out shaft (55) and bearings (53 and 54). Since bearings (53 and 54) are press fitted on the shaft, they will have to be pulled or pressed off the shaft. Remove grease seals (51) from frame (57), and bearing cap (49).

16. Remove screws (33) and nameplate (34) only if replacement is necessary.

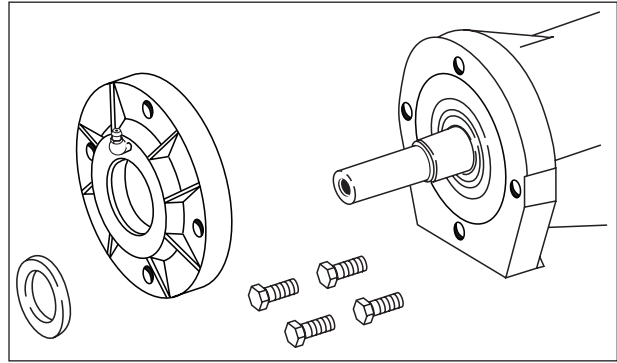

E. Bearing Cap and Slinger Removed.

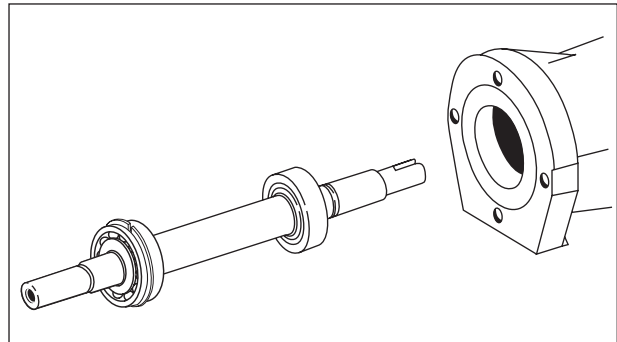

F. Shaft Assembly Removed.

### REASSEMBLY

Reassembly will generally be in reverse order of disassembly. If disassembly was not complete, use only those steps related to your particular repair program.

1. Press grease seals (51) into frame (57), and bearing cap (49). (364A)
2. Press bearings (53 and 54) onto shaft (55). Snap retainer ring (52) into place. (364A)
3. Slide shaft (55) and bearings (53 and 54) into frame (57) and place gasket (50) in place. (364A)
4. Fasten bearing cap (49) in position with capscrews (48). Position slingers (47) on the shaft. (364A)
5. On Model 364A pumps, position bracket (35) on the frame (57) and secure with capscrews (32). Tighten screws evenly to assure proper alignment. On Model 361A and 362A, position bracket (35) on the motor and secure with capscrews (32). Tighten screws evenly to assure proper alignment. On Model 361A, frame sizes 143 to 184 JP only. Fasten support (41) to bracket (35) with washers (40) and capscrews (39).

## MODELS 361A-362A-364A

6. If nameplate (34) was removed, install and attach with screws (33).
7. Replace wear ring(s) (7 and 16), in casing (6) and cover (26). Rings should not be hammered into place. Use a press, or clamp the parts in a bench vise, using wooden blocks to protect the rings. It may be necessary to pin or dowel the rings after assembly if the cover or casing has had rings replaced before, since each reassembly can stretch or tear metal and thereby loosen the fits. If the facilities are available, it is good practice to take a very light finish cut or to ream the inside diameter of the casing rings after pressing to restore roundness. When rings are pressed, they may get squeezed out of shape.
8. Coat the mating surfaces of impeller wear ring(s) (optional - 14 and 15) and impeller (11) with Loctite sealant grade 271. Replace wear rings, using the same care as for the case wear ring(s). If the rings are to be trued on a lathe, do not clamp the impeller so tightly that it is permanently distorted.
9. If water jacket (optional - 18) was removed it may be replaced at this time. Replace gaskets (19 and 19A) on cover (26) and carefully slide on water jacket making sure desired alignment is achieved. (See illustration C.) Snap retaining ring (17) behind water jacket (18) in groove provided on cover (26).
10. Reassemble the various types of stuffing boxes as follows:

### PACKING (STANDARD, WATER COOLED AND WITH LANTERN RING)

- A. If gland studs (24) are used, thread and tighten into either cover (26) or water jacket (18). Place one ring of packing (28) into the cover (26). On successive rings of packing stagger the packing joints to prevent excessive leakage through the packing box. If a lantern ring (29) is used, place a second ring of packing (28) into the cover before installing lantern ring.

## CAUTION

There must be two (2) rings of packing in front of lantern ring (29) to assure proper alignment between the lantern ring and the sealing tube connection (69) in the cover (26). Install remaining packing rings (28). Each ring should be tapped firmly into place with a wood or metal bushing.

- B. Replace pin (61) into the shaft sleeve (25) and slide the sleeve (25) through the packing making sure the pin (61) end of the sleeve (25) is in the cover side opposite the gland halves (23).
- C. Replace gland halves (23) and gland clamps (22) on studs (24). Tighten nuts (21) down finger tight. For standard pumps replace gland halves (23) and place gland clamps (22) over capscrews (65). Tighten capscrews (65) finger tight into either cover assembly (26) or water jacket (18).

### NOTE

The slots in gland halves (23) should be diagonal to pump horizontal center line.

- D. The cover assembly (26) as a unit may be replaced onto the motor shaft. Align key groove to facilitate impeller reassembly. The cover is held to motor bracket (35) by either capscrews (5) or (20). These should be installed and tightened at this time.

11. When the pump is returned to service, additional care must be given to packing box to insure proper packing life. It is necessary to allow 60 to 120 drops leakage per minute through the packing for lubrication purposes. If the flow rate is other than this, the gland nuts or capscrews should be either loosened or tightened one quarter turn at a time to acquire the correct leakage (both nuts or capscrews must be turned equally to prevent cocking of the gland). It will take approximately ten minutes at any one gland setting before the leakage rate will stabilize. When in doubt, choose the greater leakage rate since overly tight packing will ruin not only the packing, but the sleeve as well.

### MECHANICAL SEAL (OPTIONAL)

The mechanical seal (27), (see Figure 1), should not be installed as an assembly. It is necessary to have the seal seat properly in place before the balance of parts can be added.

- A. Wipe the sealing faces of the seat and seal washer clean. Apply a film of liquid dishwashing detergent (do not use oil or grease) to the flexible bellows in the rotating assembly and shaft sleeve (25). Slide the entire rotating assembly onto the sleeve making sure that the carbon washer faces away from the step in the sleeve.
- B. Thoroughly inspect the gland (23), checking for burrs or nicks which could damage flexible cup of mechanical seal. Apply a film of liquid dishwashing detergent (do not use oil or grease) to the flexible cup. Insert seat in cup and install in gland (23).

### NOTE

If it is not possible to insert seat with fingers, place cardboard protecting ring furnished with seal over lapped face of seat and press into place with a piece of tubing having end cut square. The tubing should be slightly larger than the diameter of the shaft. Remove cardboard after seat is firmly in place.

Carefully slip the seal gland assembly (23) over the shaft with the stationary seat facing away from the motor. Insert gasket (66) over shaft.

- C. The shaft sleeve with the seal rotating assembly on it may now be replaced on the shaft. Carefully slide the seal gland (23) and gasket (66) onto the sleeve before seating the sleeve (25) against the shaft shoulder.
- D. Carefully slip cover assembly (26) over the shaft into its original position and secure with either capscrews (20 or 5).
- E. Position seal gland (23) and gasket (66) onto the cover (26) taking care to seat it evenly and squarely. Secure by tightening capscrews (65) evenly. Spring tension will probably prevent the sleeve from remaining in position axially until impeller is locked against it.



## MODELS 361A-362A-364A

12. Carefully place gasket (10) on motor end of impeller. Assemble key (12) and impeller (11) to motor shaft. Secure impeller with gasket (9B), washer (9A), capscrew seal (9C) and impeller screw (9).
13. On Model 364A pumps, fasten the supports (41 and 64) to bracket (35) and frame (57) with washers (40 and 63) and capscrews (39 and 62).
14. Install the pipe plugs (4) in the pump casing (6). Position gasket (8) and casing (6) against the cover (26) and secure with capscrews (20 or 5).
15. Reassemble sealing tube assembly (optional - 69, 70, 71, and 76) in water jacket (optional - 18) as shown in illustration "C". Replace all relief, cooling, flushings, or drain lines from the pump including compression connections (1 and 2) and tubing (3). On Model 362A pumps, position gasket (72) and set pump assembly in place. Tighten pump to base (73) with capscrews (39).  
  
Replace plugs (74 and 75). Replace all grease fittings, pipe plugs, tube vents and oiler assembly for oil lubricated units.
16. Secure suction and discharge piping to the pump. Make sure to install gaskets on flanged connections.
17. Connect electricity to the motor.
18. Read carefully the section of the manual titled INSTALLATION, especially those paragraphs referring to pump and coupling alignment.

### STARTING PUMP AFTER REASSEMBLY

Do not start pump until all air and vapor has been bled and until making sure that there is liquid in the pump to provide the necessary lubrication. Without the fluid around it, the seal may be ruined in a few seconds of operation. It is possible that the mechanical seal may drip during the first few minutes to one hour of operation.



#### **Warning:** Hot Surface Hazard

If pumping hot water, insure guards or proper insulation is installed to protect against skin contact to hot piping or pump components. Failure to follow these instructions could result in serious personal injury, death or property damage.



#### **Warning:** Spraying Water Hazard

When servicing pump replace all gaskets and seals. Do not re-use old gaskets or seals. Failure to follow these instructions could result in serious personal injury, death or property damage.



#### **Warning:** Electrical Shock Hazard

All electrical connections are to be made by a qualified electrician in accordance with all codes and ordinances. Failure to follow these instructions could result in serious personal injury, death or property damage.



#### **Warning:** Electrical Overload Hazard

Insure all motors have properly sized overload protection. Failure to follow these instructions could result in serious personal injury, death or property damage.



#### **Warning:** Sudden Start-Up Hazard

Disconnect and lockout power source before servicing. Failure to follow these instructions could result in serious personal injury, death or property damage.

## READ BEFORE INITIAL STARTING OR STARTING AFTER REASSEMBLY

### **WARNING:**

On the 364A with a 15" impeller on a #21 power frame, reverse rotation will destroy the pump.

You must make sure that the motor rotates in the proper direction BEFORE coupling the motor to the pump. Start the drive motor to make sure the direction of rotation is the same as the direction indicated by the arrow on the pump casing.

The arrow on the casing always points clockwise when the pump is viewed from the motor end.

On 3 phase motors, you can reverse one of the power leads if the motor is not rotating clockwise.

### **WARNING:**

Reverse rotation will quickly destroy the pump.

After you are sure the motor is rotating clockwise you can couple the motor to the pump. Again, after coupling but BEFORE starting it is important to check coupling and shaft alignment. Use a standard dial indicator to align the motor shaft and pump shaft to within 0.003"-0.005".



MODELS 361A-362A-364A

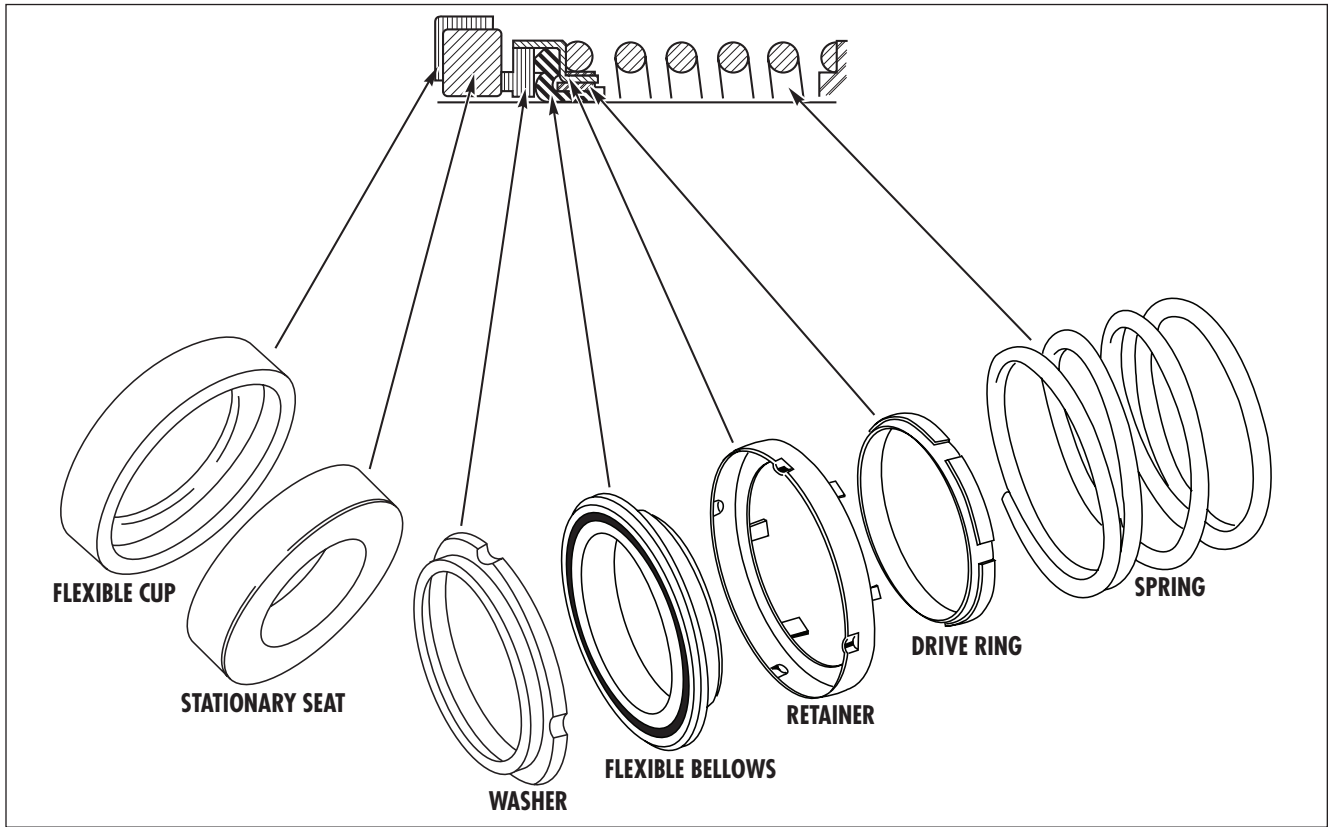

Figure 1. Mechanical Seal (optional)

**MODELS 361A-362A-364A**

**MODEL 361A LIST OF PARTS**

1. Elbow	9B. Gasket	19. Gasket	26. Cover
2. Connector	9C. Capscrew Seal	19A. Gasket	27. Seal
3. Tubing	10. Gasket	20. Capscrew	28. Packing
4. Plug, Pipe	11. Impeller	(not shown)	29. Lantern Ring
5. Capscrew	12. Impeller Key	21. Nut	32. Capscrew
6. Casing	14. Wear Ring	22. Clamp	33. Screw
7. Wear Ring	15. Wear Ring	23. Gland	34. Nameplate
8. Gasket	16. Wear Ring	24. Stud	35. Bracket
9. Impeller Screw	17. Retaining Ring	25. Sleeve	39. Capscrew
9A. Washer	18. Jacket		

**MODEL 362A LIST OF PARTS**

1. Elbow	11. Impeller	23. Gland	65. Capscrew
2. Connector	12. Impeller Key	24. Stud	66. Gasket
3. Tubing	14. Wear Ring	25. Sleeve	67. Plug, Pipe
4. Plug, Pipe	15. Wear Ring	26. Cover	68. Plug, Pipe
5. Capscrew	16. Wear Ring	27. Seal	69. Nipple
6. Casing	17. Retaining Ring	28. Packing	70. Gasket
7. Wear Ring	18. Jacket	29. Lantern Ring	71. Locknut
8. Gasket	19. Gasket	32. Capscrew	72. Gasket
9. Impeller Screw	19A. Gasket	33. Screw	73. Base
9A. Washer	20. Capscrew	34. Nameplate	74. Plug, Pipe
9B. Gasket	(not shown)	35. Bracket	75. Plug, Pipe
9C. Capscrew Seal	21. Nut	39. Capscrew	76. Coupling, Pipe
10. Gasket	22. Clamp	61. Pin	

**MODEL 364A LIST OF PARTS**

1. Elbow	17. Retaining Ring	35. Bracket	55. Shaft
2. Connector	18. Jacket	39. Capscrew	56. Plug, Pipe
3. Tubing	19. Gasket	40. Washer	57. Frame
4. Plug, Pipe	19A. Gasket	41. Support	58. Grease Fitting
5. Capscrew	20. Capscrew	42. Key	59. Plug, Pipe
6. Casing	(not shown)	43. Grease Fitting	60. Oiler Assembly
7. Wear Ring	21. Nut	44. Tube, Vent	61. Pin
8. Gasket	22. Clamp	46. Plug, Pipe	62. Capscrew
9. Impeller Screw	23. Gland	47. Slinger	63. Washer
9A. Washer	24. Stud	47A. Slinger	64. Support
9B. Gasket	25. Sleeve	48. Capscrew	65. Capscrew
9C. Capscrew Seal	26. Cover	49. Bearing Cap	66. Gasket
10. Gasket	27. Seal	50. Gasket	67. Plug, Pipe
11. Impeller	28. Packing	51. Seal	68. Plug, Pipe
12. Impeller Key	29. Lantern Ring	51A. Seal	69. Nipple
14. Wear Ring	32. Capscrew	52. Retaining Ring	70. Gasket
15. Wear Ring	33. Screw	53. Bearing	71. Locknut
16. Wear Ring	34. Nameplate	54. Bearing	76. Coupling, Pipe

**NOTES:**

1. BRONZE FITTED CONSTRUCTION WILL BE FURNISHED AS STANDARD UNLESS SPECIFIED.
2. REFER TO FACTORY FOR SPECIAL ALLOYS.
3. AURORA PUMP RESERVES THE RIGHT TO SUBSTITUTE MATERIALS WITHOUT NOTICE
4. PIECE NUMBERS 14 AND 15 ARE NOT FURNISHED AS STANDARD, WHEN FURNISHED, IMPELLER MUST BE MODIFIED.
5. PIECE NUMBERS 39, 40, 41 USED ONLY WITH MOTOR FRAMES 143 THRU 184-JM ON MODEL 361A PUMPS.

**NOTE**

**WHEN ORDERING SPARE PARTS ALWAYS INCLUDE THE PUMP TYPE, SIZE, SERIAL NUMBER, AND THE PIECE NUMBER FROM THE EXPLODED VIEW IN THIS MANUAL.**

**ORDER ALL PARTS FROM YOUR LOCAL AUTHORIZED DISTRIBUTOR, FACTORY BRANCH SALES OFFICE OR THE FACTORY AT NORTH AURORA, ILLINOIS.**

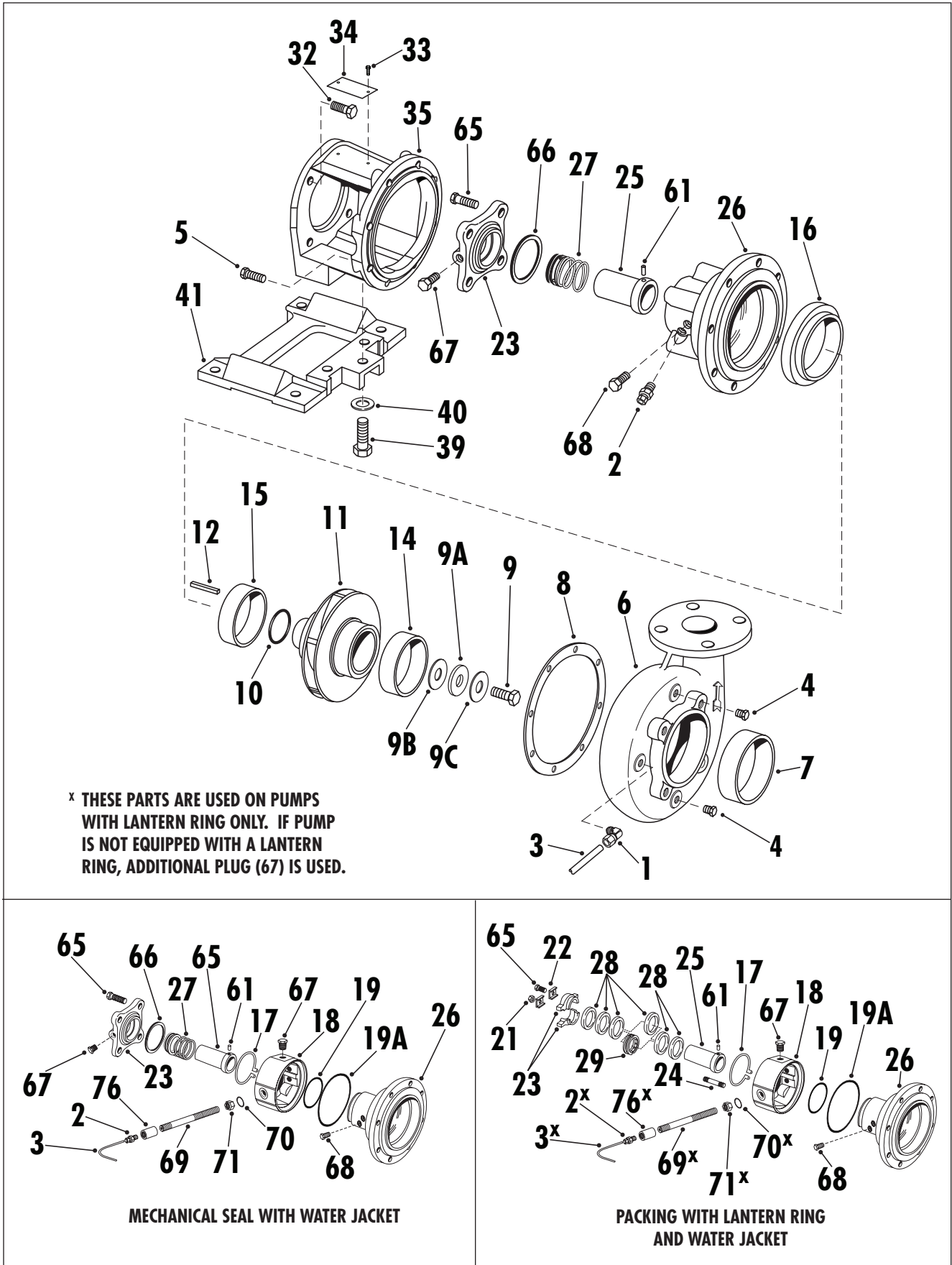

Figure 2. Exploded View

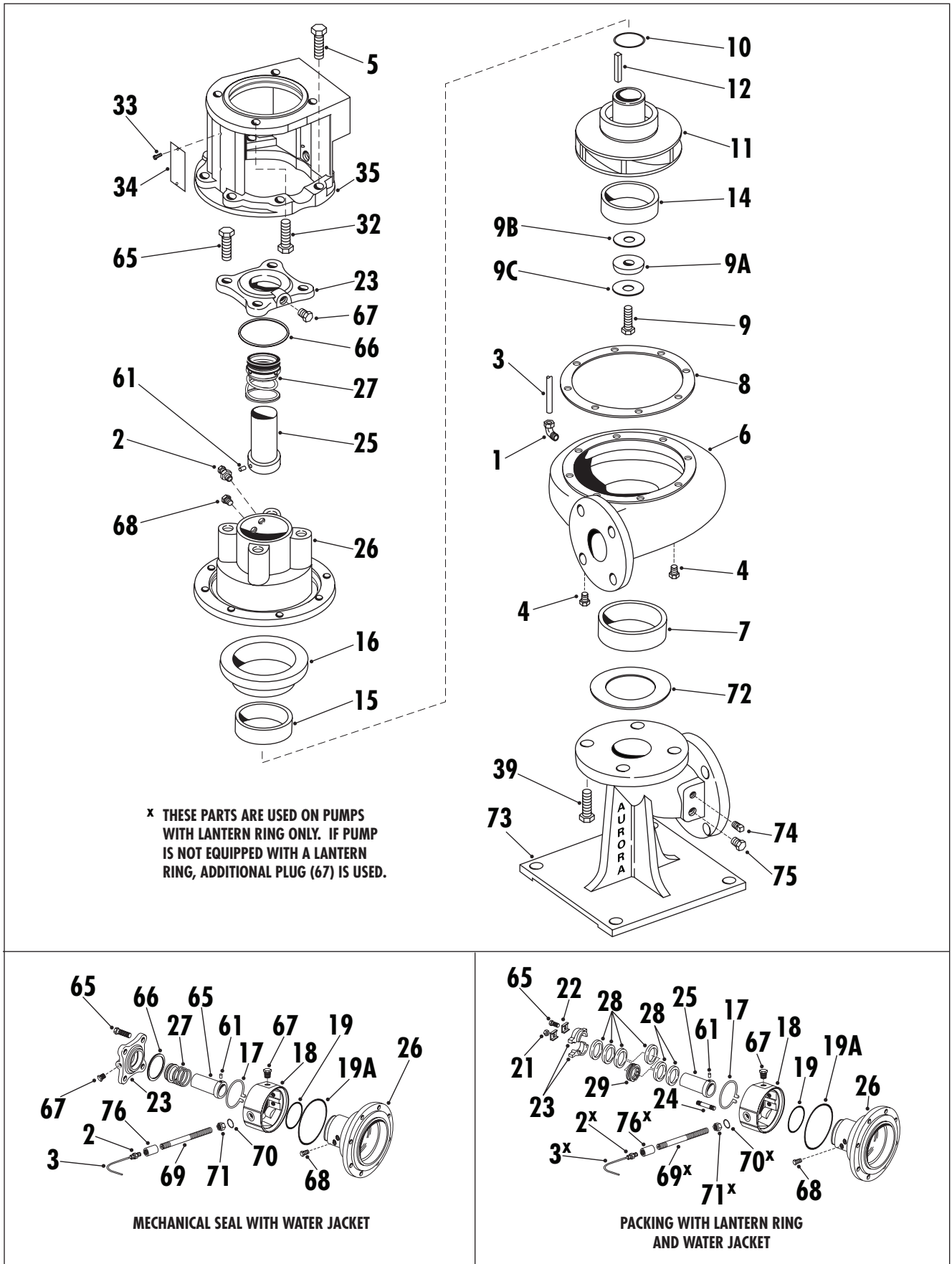
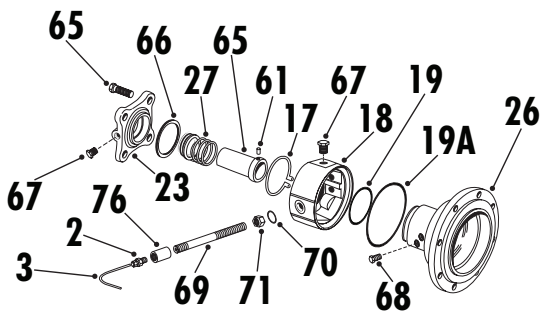
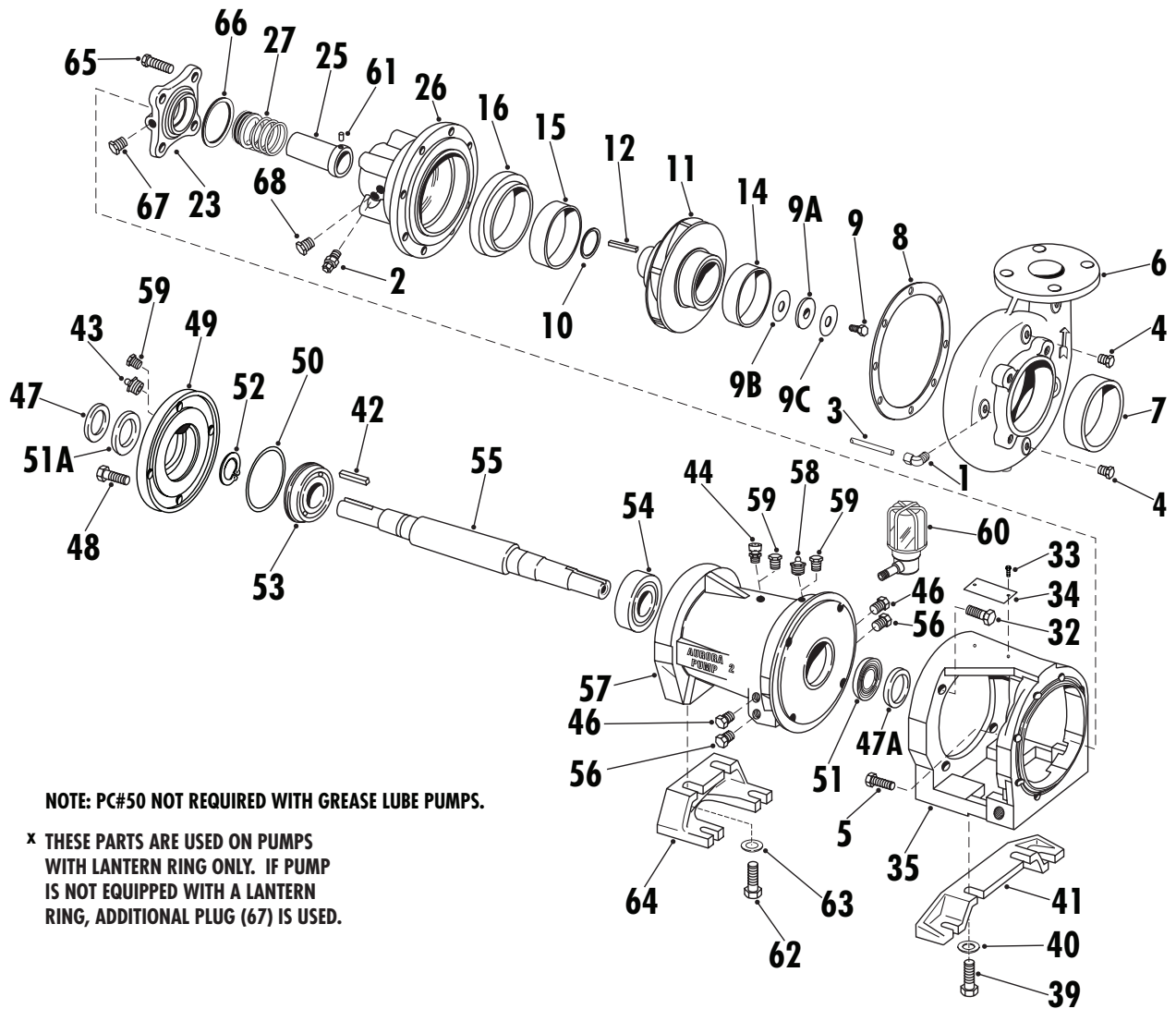
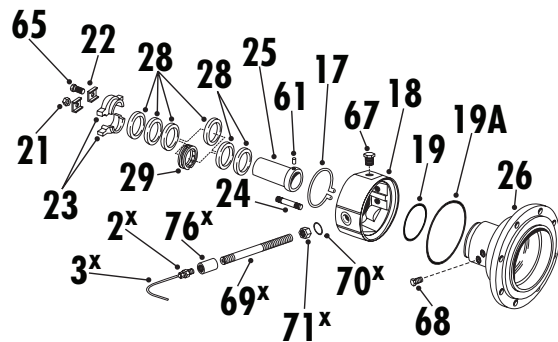

Figure 3. Exploded View



MECHANICAL SEAL WITH WATER JACKET



PACKING WITH LANTERN RING AND WATER JACKET

Figure 4. Exploded View

**THIS PAGE INTENTIONALLY LEFT BLANK**

**THIS PAGE INTENTIONALLY LEFT BLANK**



## WARRANTY

Seller warrants equipment (and its component parts) of its own manufacture against defects in materials and workmanship under normal use and service for one (1) year from the date of installation or start-up, or for eighteen (18) months after the date of shipment, whichever occurs first. Seller does not warrant accessories or components that are not manufactured by Seller; however, to the extent possible, Seller agrees to assign to Buyer its rights under the original manufacturer's warranty, without recourse to Seller. Buyer must give Seller notice in writing of any alleged defect covered by this warranty (together with all identifying details, including the serial number, the type of equipment, and the date of purchase) within thirty (30) days of the discovery of such defect during the warranty period. No claim made more than 30 days after the expiration of the warranty period shall be valid. Guarantees of performance and warranties are based on the use of original equipment manufactured (OEM) replacement parts. Seller assumes no responsibility or liability if alterations, non-authorized design modifications and/or non-OEM replacement parts are incorporated. If requested by Seller, any equipment (or its component parts) must be promptly returned to Seller prior to any attempted repair, or sent to an authorized service station designated by Seller, and Buyer shall prepay all shipping expenses. Seller shall not be liable for any loss or damage to goods in transit, nor will any warranty claim be valid unless the returned goods are received intact and undamaged as a result of shipment. Repaired or replaced material returned to customer will be shipped F.O.B., Seller's factory. Seller will not give Buyer credit for parts or equipment returned to Seller, and will not accept delivery of any such parts or equipment, unless Buyer has obtained Seller's approval in writing. The warranty extends to repaired or replaced parts of Seller's manufacture for ninety (90) days or for the remainder of the original warranty period applicable to the equipment or parts being repaired or replaced, whichever is greater. This warranty applies to the repaired or replaced part and is not extended to the product or any other component of the product being repaired. Repair parts of its own manufacture sold after the original warranty period are warranted for a period of one (1) year from shipment against defects in materials and workmanship under normal use and service. This warranty applies to the replacement part only and is not extended to the product or any other component of the product being repaired. Seller may substitute new equipment or improve part(s) of any equipment judged defective without further liability. All repairs or services performed by Seller, which are not covered by this warranty, will be charged in accordance with Seller's standard prices then in effect.

THIS WARRANTY IS THE SOLE WARRANTY OF SELLER AND SELLER HEREBY EXPRESSLY DISCLAIMS AND BUYER WAIVES ALL OTHER WARRANTIES EXPRESSED, IMPLIED IN LAW OR IMPLIED IN FACT, INCLUDING ANY WARRANTIES OF MERCHANTABILITY OR FITNESS FOR A PARTICULAR PURPOSE. Seller's sole obligation under this warranty shall be, at its option, to repair or replace any equipment (or its component parts) which has a defect covered by this warranty, or to refund the purchase price of such equipment or part. Under the terms of this warranty, Seller shall not be liable for (a) consequential, collateral, special or liquidated losses or damages; (b) equipment conditions caused by normal wear and tear, abnormal conditions of use, accident, neglect, or misuse of said equipment; (c) the expense of, and loss or damage caused by, repairs or alterations made by anyone other than the Seller; (d) damage caused by abrasive materials, chemicals, scale deposits, corrosion, lightning, improper voltage, mishandling, or other similar conditions; (e) any loss, damage, or expense relating to or resulting from installation, removal or reinstallation of equipment; (f) any labor costs or charges incurred in repairing or replacing defective equipment or parts, including the cost of reinstalling parts that are repaired or replaced by Seller; (g) any expense of shipment of equipment or repaired or replacement parts; or (h) any other loss, damage or expense of any nature.

The above warranty shall not apply to any equipment which may be separately covered by any alternate or special warranties.

**PERFORMANCE:** In the absence of Certified Pump Performance Tests, equipment performance is not warranted or guaranteed. Performance curves and other information submitted to Buyer are approximate and no warranty or guarantee shall be deemed to arise as a result of such submittal. All testing shall be done in accordance with Seller's standard policy under Hydraulic Institute procedures.

**LIABILITY LIMITATIONS:** Under no circumstances shall the Seller have any liability under the Order or otherwise for liquidated damages or for collateral, consequential or special damages or for loss of profits, or for actual losses or for loss of production or progress of construction, regardless of the cause of such damages or losses. In any event, Seller's aggregate total liability under the Order or otherwise shall not exceed the contract price.

**ACTS OF GOD:** Seller shall in no event be liable for delays in delivery of the equipment or other failures to perform caused by fires, acts of God, strikes, labor difficulties, acts of governmental or military authorities, delays in transportation or procuring materials, or causes of any kind beyond Seller's control.

**COMPLIANCE WITH LAW:** Seller agrees to comply with all United States laws and regulations applicable to the manufacturing of the subject equipment. Such compliance shall include: The Fair Labor Standards Acts of 1938, as amended; Equal Employment Opportunity clauses of Executive Order 11246, as amended; Occupational Safety and Health Act of 1970 and the standards promulgated thereunder, if applicable. Since compliance with the various Federal, State, and Local laws and regulations concerning occupational health and safety, pollution or local codes are affected by the use, installation and operation of the equipment and other matters over which Seller has no control, Seller assumes no responsibility for compliance with those laws and regulations, whether by way of indemnity, warranty, or otherwise. It is incumbent upon the Buyer to specify equipment which complies with local codes and ordinances.



**AURORA®**

800 Airport Road  
North Aurora, Illinois 60542  
630-859-7000  
[www.aurorapump.com](http://www.aurorapump.com)