

**AIR SEPARATOR**

Dated **MAY 2010**

MODELS 1050/1050S – 2" TO 3"

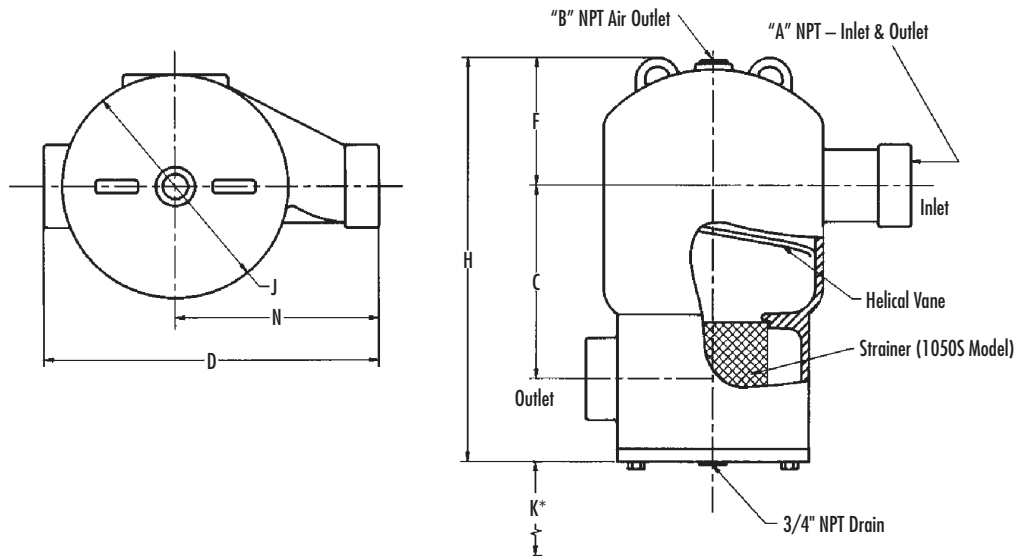

\*K is distance required to remove strainer.

Model		DIMENSIONS in inches (mm)									FLOW RATE in US gpm (l/s) for LINE VELOCITY ft/s (m/s)			WEIGHT lbs. (kg)		STRAINER SCREEN FREE AREA
Less Strainer	With Strainer	A	B	C	D	F	H	J	K	N	4 (1.22)	6 (1.83)	8 (2.44)	1050	1050S	Sq. in. (Sq. cm)
1050-2	1050-2S	2.00 (51)	0.75 (19)	7.50 (191)	12.75 (324)	4.75 (121)	15.75 (400)	8.63 (219)	7.00 (178)	7.75 (197)	42 (2.6)	63 (4.0)	84 (5.3)	70 (32)	70 (32)	40 (258)
1050-2.5	1050-2.5S	2.50 (64)	0.75 (19)	9.25 (235)	15.50 (394)	6.15 (156)	19.00 (483)	10.70 (272)	7.88 (200)	9.50 (241)	60 (3.8)	90 (5.7)	120 (7.6)	100 (45)	100 (45)	67 (432)
1050-3	1050-3S	3.00 (76)	0.75 (19)	9.25 (235)	15.50 (394)	6.15 (156)	19.00 (483)	10.70 (272)	7.88 (200)	9.50 (241)	93 (5.9)	140 (8.8)	185 (11.7)	100 (45)	100 (45)	67 (432)

**NOTE:** Dimension "K" applies only to 1050S models.

**Materials of Construction**

Shell	Cast Iron
Strainer	Stainless Steel Mesh (1/4" x 3/4")
Gasket	Non-Asbestos

**Technical Data**

Max. Working Temperature	350°F (176°C)
Max. Working Pressure	160 psi (1105 kPa)
Connection Type	Threaded NPT

**Typical Specification**

ASME Coded Units	Non-ASME Coded Units
Furnish & install an Aurora Air Separator, Model ___ 1050 or Model ___ 1050S (with strainer) with NPT tangential connections as shown on plans. The unit shall be designed and built in accordance with the latest revisions of ASME Pressure Vessel Code, Section VIII, Division 1. A blowdown connection is provided for routine cleaning of the unit.	Furnish & install an Aurora Air Separator, Model ___ 1050 or Model ___ 1050S (with strainer) with NPT tangential connections as shown on plans. The unit is considered as "part of the piping" and no Code Inspection applies. A blowdown connection is provided for routine cleaning of the unit.

# AURORA ACCESSORIES

## AIR SEPARATOR

MODELS 1050/1050S - 4" TO 12"

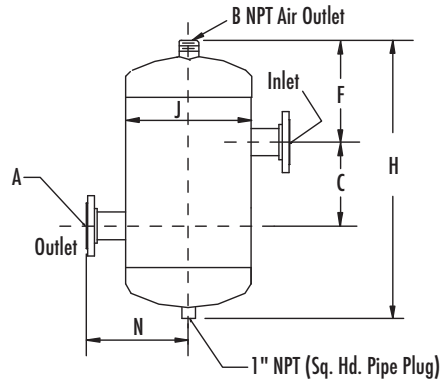
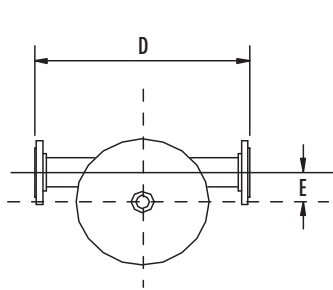

**Model 1050**

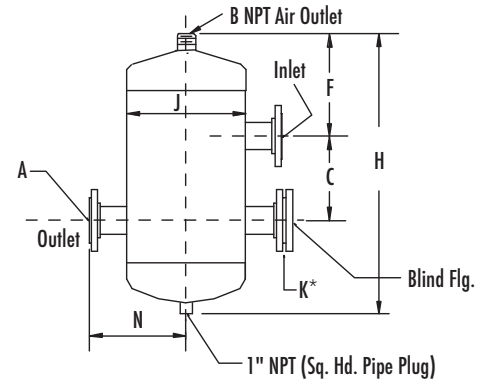

**Model 1050S**

\*K is distance required to remove strainer.

Model		DIMENSIONS in inches (mm)										MAX. FLOW RATE in US gpm (l/s) for LINE VELOCITY ft/s (m/s)			WEIGHT lbs. (kg)		STRAINER SCREEN FREE AREA
Less Strainer	With Strainer	A	B	C	D	E	F	H	J	K	N	4 (1.22)	6 (1.83)	8 (2.44)	1050	1050S	Sq. in. (Sq. cm)
1050-4	1050-4S	4.00 (102)	1.50 (38)	9.50 (241)	18.00 (457)	2.25 (57)	6.80 (173)	22.25 (565)	10.75 (273)	16.00 (406)	9.00 (229)	160 (10.1)	240 (15.1)	320 (20.2)	121 (55)	151 (69)	76 (490)
1050-5	1050-5S	5.00 (127)	1.50 (38)	11.00 (279)	20.00 (508)	2.88 (73)	8.69 (221)	28 (711)	12.75 (324)	19.00 (483)	10.00 (254)	250 (9.84)	375 (14.8)	500 (31.6)	173 (79)	207 (94)	124 (800)
1050-6	1050-6S	6.00 (152)	1.50 (38)	12.50 (318)	24.00 (610)	4.00 (102)	9.85 (250)	32.24 (819)	16.00 (406)	22.00 (558)	12.00 (305)	360 (22.7)	540 (34.1)	720 (45.4)	264 (120)	306 (139)	183 (1181)
1050-8	1050-8S	8.00 (203)	2.00 (51)	16.00 (406)	28.00 (711)	5.00 (127)	12.81 (310)	41.25 (1048)	20.00 (508)	26.00 (660)	14.00 (356)	630 (39.8)	940 (59.3)	1250 (78.9)	228 (103)	332 (151)	302 (1949)
1050-10	1050-10S	10.00 (254)	2.00 (51)	20.00 (508)	32.00 (813)	5.75 (146)	15.00 (381)	49.50 (1257)	24.00 (610)	29.00 (737)	16.00 (406)	990 (62.5)	1500 (94.6)	1980 (124.9)	390 (177)	547 (248)	452 (2916)
1050-12	1050-12S	12.00 (305)	2.00 (51)	26.00 (660)	38.00 (965)	7.75 (197)	17.56 (446)	61.25 (1556)	30.00 (762)	36.00 (914)	19.00 (483)	1400 (88.3)	2100 (132.5)	2800 (176.7)	609 (276)	856 (388)	679 (4381)

**Materials of Construction**

Shell	4" to 6" Models: Cast Iron 8" to 12" Models: Fabricated Steel
Strainer	Stainless Steel Mesh (1/4" x 3/4")
Gasket	Non-Asbestos

**Technical Data**

Max. Working Temperature	375°F (190°C)
Max. Working Pressure	4" to 6" Models: 160 psi (1103 kPa) 8" to 12" Models: 165 psi (1140 kPa)
Connection Type	150# Flanged ANSI (RF50)

All models designed and built to ASME Pressure Vessel Code, Section VIII, Division 1.

**Typical Specification**

Furnish & install an Aurora Air Separator, Model \_\_\_\_ 1050 or Model \_\_\_\_ 1050S (with strainer) with flanged tangential connections as shown on plans. The unit shall be designed and built in accordance with the latest revisions of ASME Pressure Vessel Code, Section VIII, Division 1. A blowdown connection is provided for routine cleaning of the unit.

# AURORA ACCESSORIES

## AIR SEPARATOR

MODELS 1050/1050S - 14" TO 24"

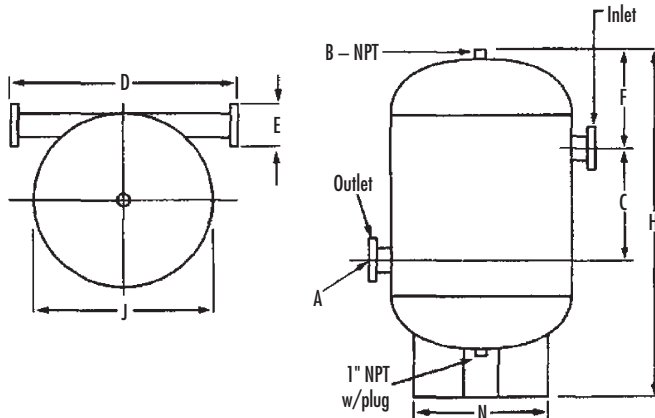

Model 1050

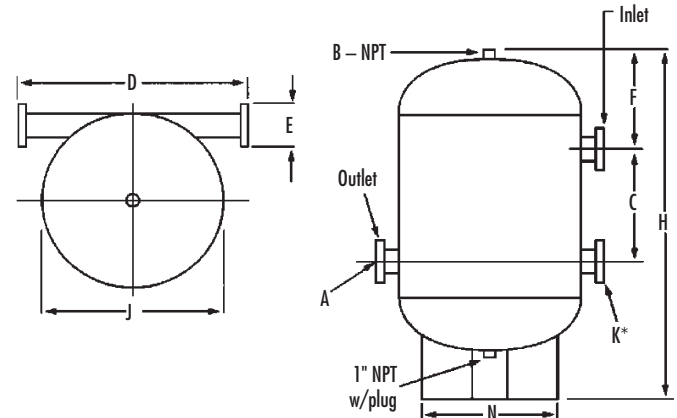

Model 1050S

\*K is distance required to remove strainer.

Model		DIMENSIONS in inches (mm)										MAX. FLOW RATE in US gpm (l/s) for LINE VELOCITY ft/s (m/s)			WEIGHT lbs. (kg)		STRAINER SCREEN FREE AREA
Less Strainer	With Strainer	A	B	C	D	E	F	H	J	K	N	4 (1.22)	6 (1.83)	8 (2.44)	1050	1050S	Sq. in. (Sq. cm)
1050-14	1050-14S	14 (356)	2 (51)	31.50 (800)	46.38 (1178)	14 (356)	22 (559)	78 (1981)	36 (914)	46 (1168)	30 (762)	1680 (106.0)	2500 (157.7)	3350 (211.4)	1680 (762)	1848 (838)	810 (5226)
1050-16	1050-16S	16 (406)	2 (51)	40 (1016)	60 (1524)	16 (406)	30 (762)	108 (2743)	48 (1219)	60 (1524)	38 (965)	2200 (138.8)	2800 (176.7)	3500 (220.8)	2300 (1043)	2530 (1148)	969 (6252)
1050-18	1050-18S	18 (457)	2 (51)	50 (1270)	66 (1676)	18 (457)	33 (838)	124 (3150)	54 (1372)	67 (1702)	44 (1118)	3300 (208.2)	4200 (265.0)	5200 (328.1)	3235 (1467)	3559 (1614)	1517 (9787)
1050-20	1050-20S	20 (508)	2 (51)	60 (1524)	72 (1829)	20 (508)	35 (889)	138 (3505)	60 (1524)	72 (1829)	50 (1270)	4500 (283.9)	5600 (353.3)	7000 (441.6)	5100 (2313)	5610 (2545)	1860 (12000)
1050-22	1050-22S	22 (559)	2 (51)	66 (1676)	78 (1981)	22 (559)	38 (965)	150 (3810)	66 (1676)	80 (2032)	56 (1422)	5000 (315.5)	6300 (397.5)	7900 (498.4)	6150 (2790)	6765 (3069)	2073 (13374)
1050-24	1050-24S	24 (610)	2 (51)	66 (1676)	78 (1981)	22 (559)	38 (965)	150 (3810)	66 (1676)	85 (2159)	56 (1422)	5500 (347.0)	7000 (441.6)	8800 (551.21)	6400 (2903)	7931 (3597)	2712 (17497)

Custom sizes larger than 24" available.

### Materials of Construction

Shell	Fabricated Steel
Strainer	Steel Mesh (1/4" x 3/4")
Gasket	Non-Asbestos

### Technical Data

Max. Working Temperature	450° (232°C)
Max. Working Pressure	125 psi (865 kPa)
Connection Type	150# Flanged ANSI (RFSO)

All models designed and built to ASME Pressure Vessel Code, Section VIII, Division 1.

### Typical Specification

Furnish & install an Aurora Air Separator, Model \_\_\_\_ 1050 or Model \_\_\_\_ 1050S (with strainer) with flanged tangential connections as shown on plans. The unit shall be designed and built in accordance with the latest revisions of ASME Pressure Vessel Code, Section VIII, Division 1. A blowdown connection is provided for routine cleaning of the unit.

# AURORA ACCESSORIES

## AUTOMATIC AIR ELIMINATOR

MODEL 1050AE

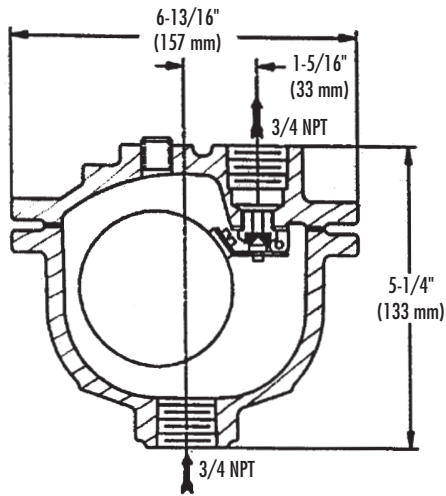

### Specifications

Maximum Operating Temperature	250°F (121°C)
Air Elimination Range	2 to 133 psi (9 bar)

### Materials of Construction

Cover and Body	Cast Iron
Control Portion	Stainless Steel
Bolts	Carbon Steel
Valve Seat	Viton
Weight	8 Lbs.

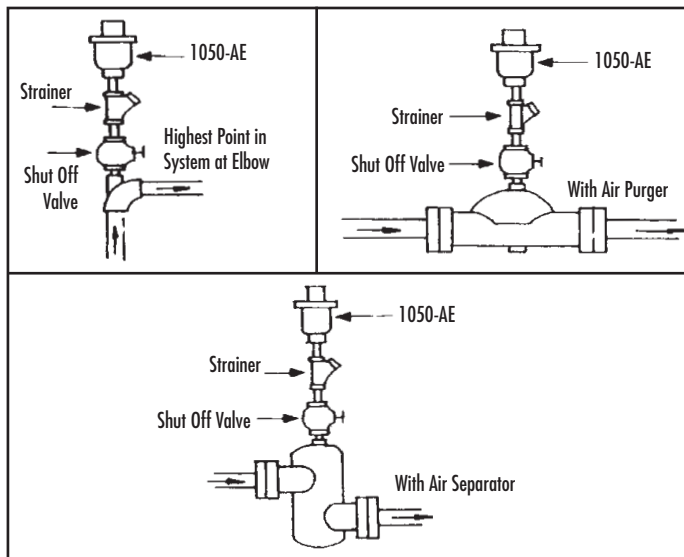

### Installation

1. Install the 1050-AE in a vertical position with the system connection at 6 o'clock and the air passage to atmosphere at 12 o'clock.
2. The air passage opening at the top must be kept open and not plugged or blocked. It is recommended that a drain tube be installed from this opening to an open drain to prevent water damage in the event the operating mechanism becomes fouled by foreign material.
3. A strainer is recommended (installed as shown) on systems that could contain suspended particles which would affect the proper operation of this vent.

**AURORA ACCESSORIES**

AIR ELIMINATOR  
MODEL 1050-AE1 – 1"

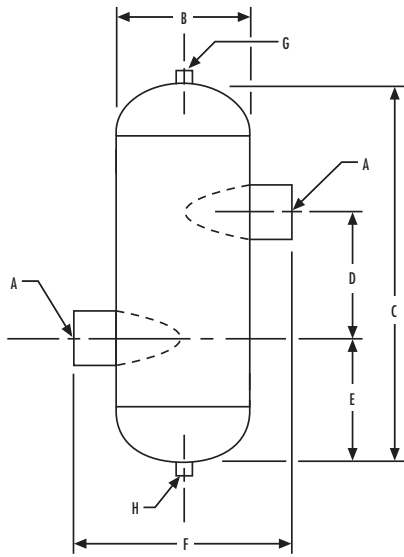

**Materials of Construction**

Body	Steel
System Connection	Steel

Designed and constructed per ASME, Section VIII, Division 1.

**Maximum Operating Conditions**

Working Temperature	350°F (176°C)
Working Pressure	125 psi (862 kPa)

Model	A	B	C	D	E	F	G	H	Shipping Weight lbs. (kg)
	NPT	inches (mm)	inches (mm)	inches (mm)	inches (mm)	inches (mm)	NPT	NPT	
1050-AE1	1.00	4.50 (114)	12.00 (305)	4.00 (102)	4.00 (102)	7.00 (178)	0.75	0.75	15 (7)