

A					B				
CPLG SIZE	HUB DESIGN	MAX. BORE	MIN. BORE	DH	L	E	L1	T	SETSCREW
24	1	.938	.354	2.20	3.07	.71	1.18	.39	M5
	1a	1.125	.866						

4
256 2890 000
THRU
256 2907 000

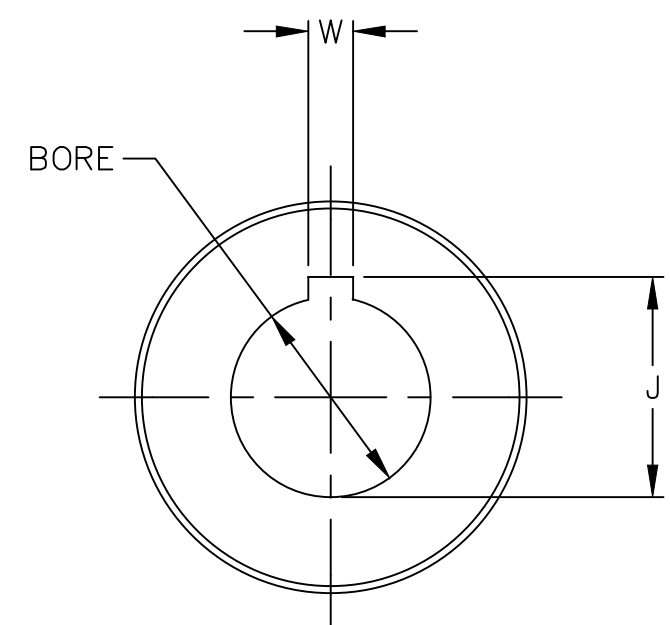
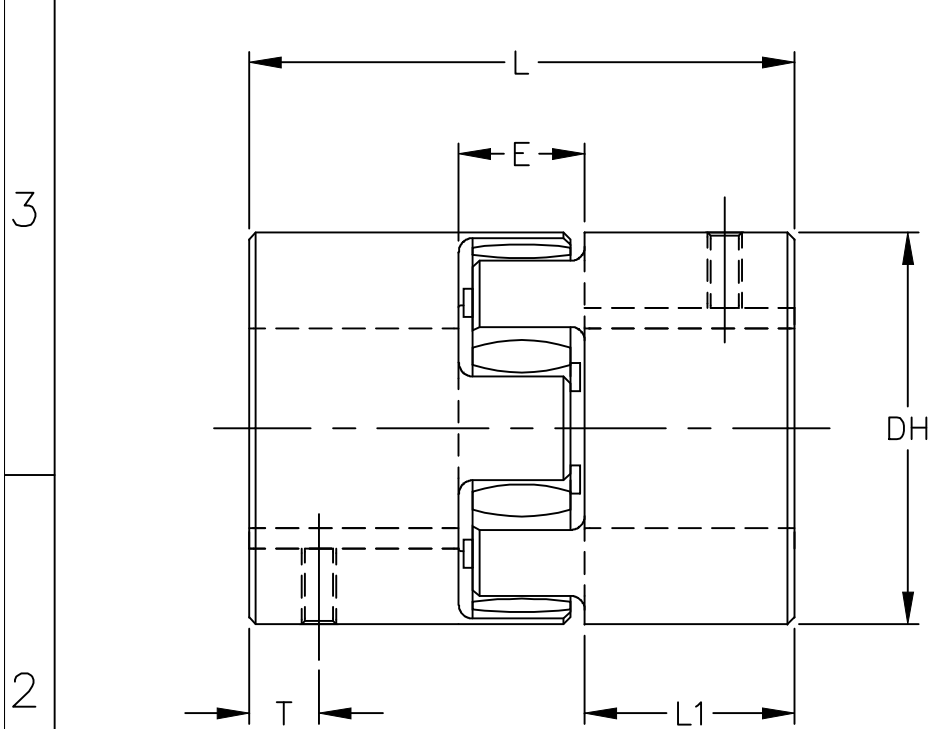

CPLG SIZE	BORE	KEYSEAT		J +.005 -.005	W +.002 -.000	PART NO.	
		STANDARD	SPECIAL				
24						2890	
						2891	
						2892	
						2893	
						2894	
						2895	
	.590*	-	1/8x1/16		.656	.125	2896
	.625	3/16x3/32	-		.714	.188	2897
							2898
	.750	3/16x3/32	-		.842	.188	2899
	.787*	-	5/32x5/64		.867	.156	2900
	.813	3/16x3/32	-		.905	.188	2901
	.875	3/16x3/32	-		.969	.188	2902
							2903
.984*	-	1/4x1/8		1.103	.250	2904	
1.000	1/4x1/8	-		1.119	.250	2905	
1.063	1/4x1/8	-		1.183	.250	2906	
1.125	1/4x1/8	-		1.246	.250	2907	

* - NOTE BORE .590 IS EQUAL TO 15mm.
 * - NOTE BORE .787 IS EQUAL TO 20mm.
 * - NOTE BORE .984 IS EQUAL TO 25mm.

- NOTES:
1. THESE PART NUMBERS ARE FOR COUPLING HUB HALF ONLY. HUBS ARE SUPPLIED STANDARD WITH ONE SET SCREW. INSERT SPIDERS REFERENCE PART NO. 448 1044 000. FOR COMPLETE COUPLING, TWO COUPLING HUBS ARE NEEDED WITH ONE INSERT SPIDER.
 2. KTR CORP. ROTEX 24 CURVE JAW COUPLINGS.
 3. FOR INCH SIZES, BORES TO BE CLEARANCE-FIT. INCH TOLERANCE PER AGMA 9002-A86 CLASS 1 FIT; KEYWAY TOLERANCES PER ANSI B17.1
 4. FOR METRIC SIZES, BORES TO BE CLEARANCE-FIT. METRIC TOLERANCE PER ISO H7 FIT; KEYWAY TOLERANCES PER DIN 6885, Js9
 5. KTR PART DESCRIPTION: ROTEX 24 SINTER STEEL COUPLING HUB.

THESE BORES PROVIDE A SLIP FIT.

BORE (IN.)	TOLERANCE
UP TO 2.000	+.001 TO -.000

DO NOT SCALE DRAWING PLOT SCALE 1 = 1					Pentair Water Pump Division North Aurora Operations	
COMPANY CONFIDENTIAL: Information contained herein is confidential, it is the property of Pentair Water. It is to be used solely for the purpose provided, and it is not to be disclosed to others without the prior written consent of Pentair Water.						
REV	DATE	REVISION	BY	CK'D	DRAWN BY JPD DATE 04/25/07 CHECKED BY JLF APPROVED BY JLF	CURVE JAW TYPE COUPLINGS ROTEX 24 ELASTOMER-IN-COMPRESSION REV - 256 2890 000 SIZE B 256 2907 000

NOTES:
 1. FINISH = 125 RMS.
 2. 2 PLACE DECIMALS ± .06.
 3. 3 PLACE DECIMALS ± .010.
 4. ANGULAR DIMENSIONS ± 1/2°.
 5. CHAMF. ALL MACH'D. SURFACE .005-.010x45° AND REMOVE ALL BURRS.
 6. ALL PARTS MUST BE FREE FROM SCALE.
 7. NO TOLERANCE NEEDED ON REFERENCE DIMENSIONS.
 8. ALL BOLT CIRCLE TOLERANCE PER ANSI B16.5.
 9. CONCENTRICITY TO CENTERLINE .005.

A B C D

A					B				
CPLG SIZE	HUB DESIGN	MAX. BORE	MIN. BORE	DH	L	E	L1	T	SETSCREW
28	1a	1.563	--	2.56	3.54	.79	1.38	.59	M8

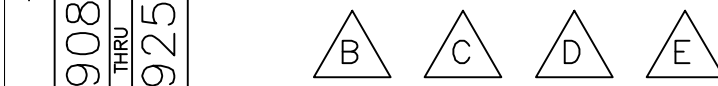

CPLG SIZE	BORE	KEYSEAT		J +.005 -.005	W +.002 -.000	PART NO.
		STANDARD	SPECIAL			
28						2908
	.590*	-	1/8x1/16	.656	.125	2909
	.625	3/16x3/32	-	.714	.188	2910
	.750	3/16x3/32	-	.842	.188	2911
	.787*	-	5/32x5/64	.867	.156	2912
						2913
	.875	3/16x3/32	-	.969	.188	2914
	.984*	-	1/4x1/8	1.103	.250	2915
	1.000	1/4x1/8	-	1.119	.250	2916
	1.063	1/4x1/8	-	1.183	.250	2917
	1.125	1/4x1/8	-	1.246	.250	2918
	1.181*	-	3/16x3/32	1.277	.188	2919
						2920
	1.250	1/4x1/8	-	1.372	.250	2921
						2922
	1.375	5/16x5/32	-	1.523	.313	2923
1.375	-	3/8x3/16	1.546	.375	2924	
1.500	3/8x3/16	-	1.674	.375	2925	

- * - NOTE BORE .590 IS EQUAL TO 15mm.
- * - NOTE BORE .787 IS EQUAL TO 20mm.
- * - NOTE BORE .984 IS EQUAL TO 25mm.
- * - NOTE BORE 1.181 IS EQUAL TO 30mm.

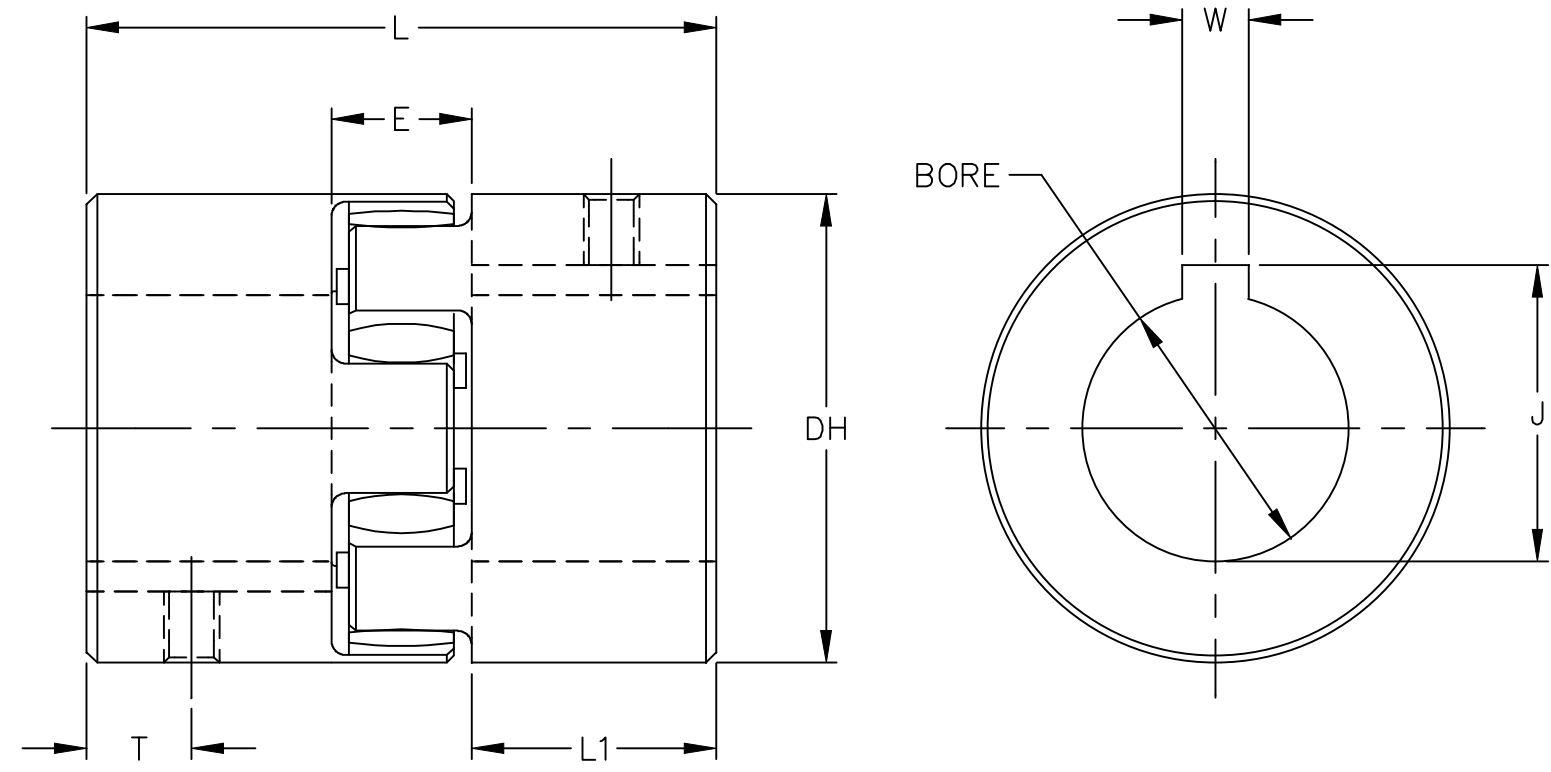

- NOTES:
- THESE PART NUMBERS ARE FOR COUPLING HUB HALF ONLY. HUBS ARE SUPPLIED STANDARD WITH ONE SET SCREW. INSERT SPIDERS REFERENCE PART NO. 448 1045 000. FOR COMPLETE COUPLING, TWO COUPLING HUBS ARE NEEDED WITH ONE INSERT SPIDER.
 - KTR CORP. ROTEX 28 CURVE JAW COUPLINGS.
 - FOR INCH SIZES, BORES TO BE CLEARANCE-FIT. INCH TOLERANCE PER AGMA 9002-A86 CLASS 1 FIT; KEYWAY TOLERANCES PER ANSI B17.1
 - FOR METRIC SIZES, BORES TO BE CLEARANCE-FIT. METRIC TOLERANCE PER ISO H7 FIT; KEYWAY TOLERANCES PER DIN 6885, Js9
 - KTR PART DESCRIPTION: ROTEX 28 MACHINED STEEL COUPLING HUB.



THESE BORES PROVIDE A SLIP FIT.

BORE (IN.)	TOLERANCE
UP TO 2.000	+.001 TO -.000

REV	DATE	REVISION	BY	CK'D
E	02/19/08	WAS DH 2.64	JD	JD
D	02/19/08	WAS .394 & 1.102	JD	JD
C	02/19/08	WAS 1.125 & 1.500	JD	JD
B	02/19/08	WAS 1 & 1a HUB	JD	JD
A	02/19/08	WAS CAST ALUMINUM	JD	JD

DO NOT SCALE DRAWING
PLOT SCALE 1 = 1

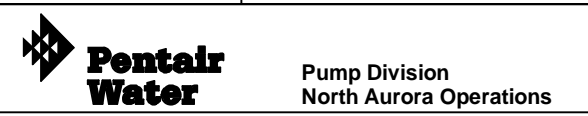

COMPANY CONFIDENTIAL: Information contained herein is confidential, it is the property of Pentair Water. It is to be used solely for the purpose provided, and it is not to be disclosed to others without the prior written consent of Pentair Water.

- NOTES:
- FINISH = 125 RMS.
 - 2 PLACE DECIMALS ± .06.
 - 3 PLACE DECIMALS ± .010.
 - ANGULAR DIMENSIONS ± 1/2°.
 - CHAMF. ALL MACH'D. SURFACE .005-.010x45° AND REMOVE ALL BURRS.
 - ALL PARTS MUST BE FREE FROM SCALE.
 - NO TOLERANCE NEEDED ON REFERENCE DIMENSIONS.
 - ALL BOLT CIRCLE TOLERANCE PER ANSI B16.5.
 - CONCENTRICITY TO CENTERLINE .005.

REV	DATE	REVISION	BY	CK'D
JPD	04/25/07		JLF	JLF

CURVE JAW TYPE COUPLINGS ROTEX 28 ELASTOMER-IN-COMPRESSION

REV E	256 2908 000
SIZE	THRU
REV B	256 2925 000

A					B				
CPLG SIZE	HUB DESIGN	MAX. BORE	MIN. BORE	DH	L	E	L1	T	SETSCREW
38	1	1.500	.472	3.15	4.49	.94	1.77	.59	M8
	1a	1.750	1.496						



CPLG SIZE	BORE	KEYSEAT		J +.005 -.005	W +.002 -.000	PART NO.
		STANDARD	SPECIAL			
38						2926
	.625	3/16x3/32	-	.714	.188	2927
	.750	3/16x3/32	-	.842	.188	2928
	.787*	-	5/32x5/64	.867	.156	2929
	.875	3/16x3/32	-	.969	.188	2930
						2931
	1.000	1/4x1/8	-	1.119	.250	2932
	1.063	1/4x1/8	-	1.183	.250	2933
	1.125	1/4x1/8	-	1.246	.250	2934
	1.181*	-	3/16x3/32	1.277	.188	2935
	1.250	1/4x1/8	-	1.372	.250	2936
						2937
	1.375	5/16x5/32	-	1.523	.313	2938
	1.375	-	3/8x3/16	1.546	.375	2939
	1.500	3/8x3/16	-	1.674	.375	2940
1.625	3/8x3/16	-	1.801	.375	2941	
1.688	3/8x3/16	-	1.864	.375	2942	
1.750	3/8x3/16	-	1.927	.375	2943	

* - NOTE BORE .787 IS EQUAL TO 20mm.
 * - NOTE BORE 1.181 IS EQUAL TO 30mm.

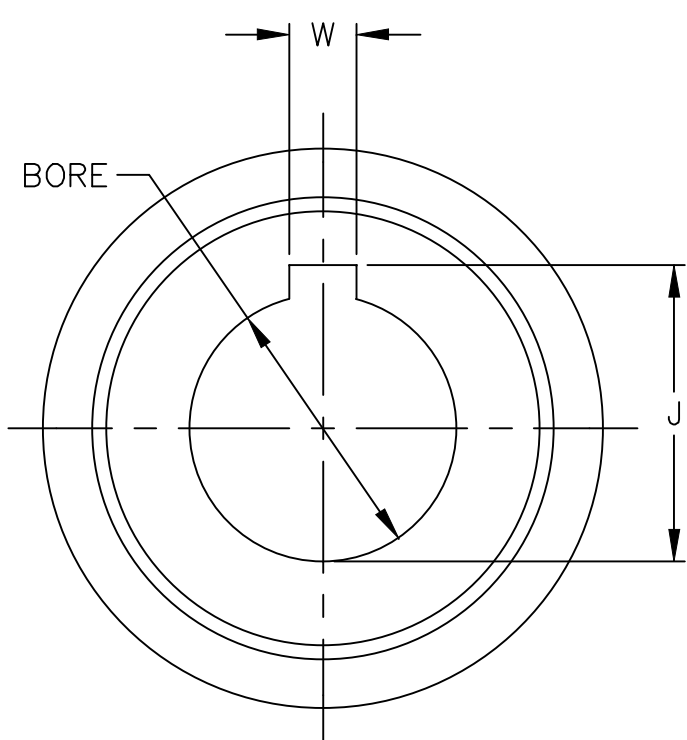
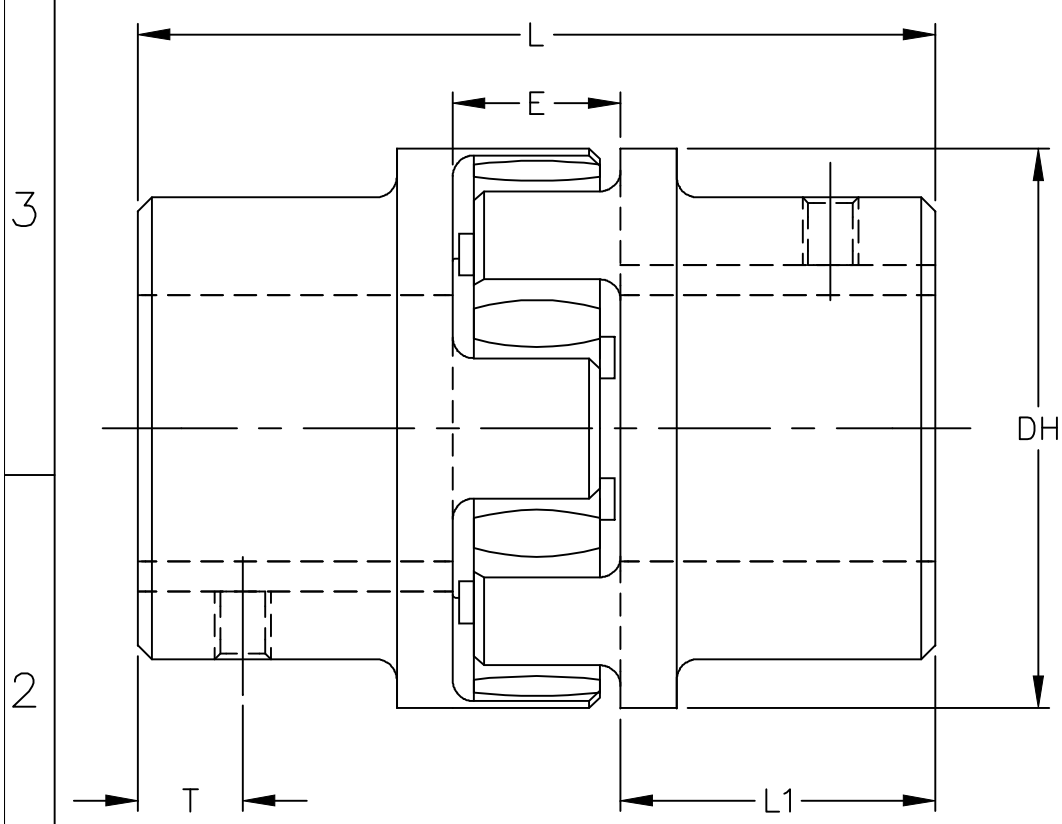

- NOTES:
1. THESE PART NUMBERS ARE FOR COUPLING HUB HALF ONLY. HUBS ARE SUPPLIED STANDARD WITH ONE SET SCREW. INSERT SPIDERS REFERENCE PART NO. 448 1046 000. FOR COMPLETE COUPLING, TWO COUPLING HUBS ARE NEEDED WITH ONE INSERT SPIDER.
 2. KTR CORP. ROTEX 38 CURVE JAW COUPLINGS.
 3. FOR INCH SIZES, BORES TO BE CLEARANCE-FIT. INCH TOLERANCE PER AGMA 9002-A86 CLASS 1 FIT; KEYWAY TOLERANCES PER ANSI B17.1
 4. FOR METRIC SIZES, BORES TO BE CLEARANCE-FIT. METRIC TOLERANCE PER ISO H7 FIT; KEYWAY TOLERANCES PER DIN 6885, Js9
 5. KTR PART DESCRIPTION: ROTEX 38 CAST IRON COUPLING HUB.

THESE BORES PROVIDE A SLIP FIT.

BORE (IN.)	TOLERANCE
UP TO 2.000	+.001 TO -.000

				DO NOT SCALE DRAWING PLOT SCALE 1 = 1		 Pentair Water Pump Division North Aurora Operations
A	01/24/08	REVISED DH DIMENSION TO 3.15 WAS 2.64	FV	DD	COMPANY CONFIDENTIAL: Information contained herein is confidential, it is the property of Pentair Water. It is to be used solely for the purpose provided, and it is not to be disclosed to others without the prior written consent of Pentair Water.	
REV	DATE	REVISION	BY	CK'D		
NOTES:				STANDARD TOLERANCES UNLESS OTHERWISE SPECIFIED.		DRAWN BY JPD DATE 04/25/07 CHECKED BY JLF APPROVED BY JLF
1. FINISH = 125 RMS.				CURVE JAW TYPE COUPLINGS ROTEX 38 ELASTOMER-IN-COMPRESSION		
2. 2 PLACE DECIMALS ± .06.				REV A		
3. 3 PLACE DECIMALS ± .010.				SIZE		
4. ANGULAR DIMENSIONS ± 1/2°.				256 2926 000		
5. CHAMF. ALL MACH'D. SURFACE .005-.010x45° AND REMOVE ALL BURRS.				THRU		
6. ALL PARTS MUST BE FREE FROM SCALE.				256 2943 000		
7. NO TOLERANCE NEEDED ON REFERENCE DIMENSIONS.						
8. ALL BOLT CIRCLE TOLERANCE PER ANSI B16.5.						
9. CONCENTRICITY TO CENTERLINE .005.						

A					B				
CPLG SIZE	HUB DESIGN	MAX. BORE	MIN. BORE	DH	L	E	L1	T	SETSCREW
42	1	1.688	.551	3.74	4.96	1.02	1.97	.79	M8
	1a	2.125	1.654						

CPLG SIZE	BORE	KEYSEAT		J +.005 -.005	W +.002 -.000	PART NO.
		STANDARD	SPECIAL			
42	.625	3/16x3/32	-	.714	.188	2944
	.750	3/16x3/32	-	.842	.188	2945
	.875	3/16x3/32	-	.969	.188	2946
	1.000	1/4x1/8	-	1.119	.250	2947
	1.063	1/4x1/8	-	1.183	.250	2948
	1.125	1/4x1/8	-	1.246	.250	2949
						2950
	1.250	1/4x1/8	-	1.372	.250	2951
						2952
	1.375	5/16x5/32	-	1.523	.313	2953
	1.375	-	3/8x3/16	1.546	.375	2954
	1.500	3/8x3/16	-	1.674	.375	2955
	1.625	3/8x3/16	-	1.801	.375	2956
	1.688	3/8x3/16	-	1.864	.375	2957
	1.750	3/8x3/16	-	1.927	.375	2958
1.875	1/2x1/4	-	2.101	.500	2959	
2.000	1/2x1/4	-	2.228	.500	2960	
2.125	1/2x1/4	-	2.355	.500	2961	

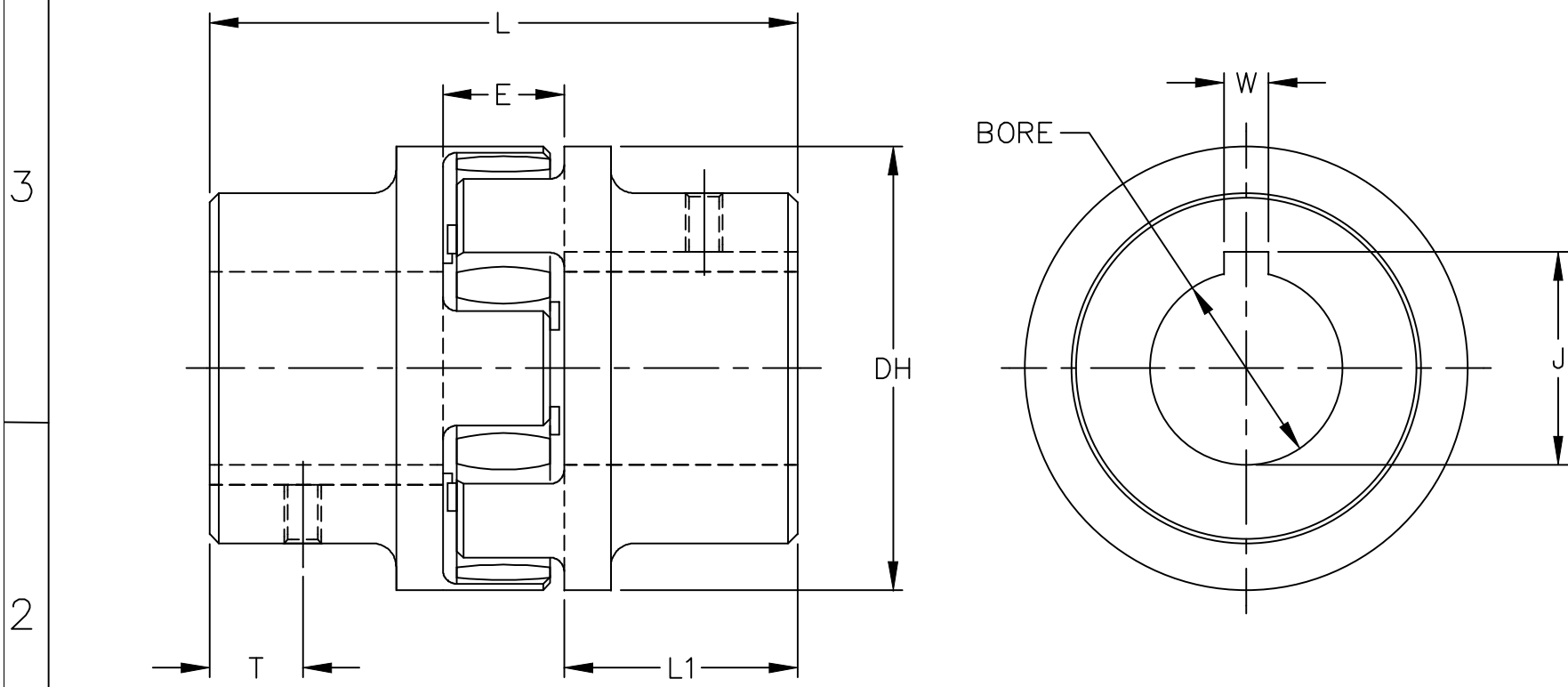

- NOTES:
1. THESE PART NUMBERS ARE FOR COUPLING HUB HALF ONLY. HUBS ARE SUPPLIED STANDARD WITH ONE SET SCREW. INSERT SPIDERS REFERENCE PART NO. 448 1047 000. FOR COMPLETE COUPLING, TWO COUPLING HUBS ARE NEEDED WITH ONE INSERT SPIDER.
 2. KTR CORP. ROTEX 42 CURVE JAW COUPLINGS.
 3. FOR INCH SIZES, BORES TO BE CLEARANCE-FIT. INCH TOLERANCE PER AGMA 9002-A86 CLASS 1 FIT; KEYWAY TOLERANCES PER ANSI B17.1
 4. FOR METRIC SIZES, BORES TO BE CLEARANCE-FIT. METRIC TOLERANCE PER ISO H7 FIT; KEYWAY TOLERANCES PER DIN 6885, Js9
 5. KTR PART DESCRIPTION: ROTEX 42 CAST IRON COUPLING HUB.

THESE BORES PROVIDE A SLIP FIT.

BORE (IN.)	TOLERANCE
UP TO 2.000	+.001 TO -.000
OVER 2.000	+.0015 TO -.000

DO NOT SCALE DRAWING PLOT SCALE .75 = 1					Pentair Water Pump Division North Aurora Operations	
COMPANY CONFIDENTIAL: Information contained herein is confidential, it is the property of Pentair Water. It is to be used solely for the purpose provided, and it is not to be disclosed to others without the prior written consent of Pentair Water.						
REV	DATE	REVISION	BY	CK'D	DRAWN BY JPD DATE 04/25/07 CHECKED BY JLF APPROVED BY JLF	CURVE JAW TYPE COUPLINGS ROTEX 42 ELASTOMER-IN-COMPRESSION REV - 256 2944 000 SIZE B 256 2961 000
NOTES: 1. FINISH = 125 RMS. 2. 2 PLACE DECIMALS ± .06. 3. 3 PLACE DECIMALS ± .010. 4. ANGULAR DIMENSIONS ± 1/2°. 5. CHAMF. ALL MACH'D. SURFACE .005-.010x45° AND REMOVE ALL BURRS. 6. ALL PARTS MUST BE FREE FROM SCALE. 7. NO TOLERANCE NEEDED ON REFERENCE DIMENSIONS. 8. ALL BOLT CIRCLE TOLERANCE PER ANSI B16.5. 9. CONCENTRICITY TO CENTERLINE .005.					STANDARD TOLERANCES UNLESS OTHERWISE SPECIFIED.	

A					B					C	D				
CPLG SIZE	HUB DESIGN	MAX. BORE	MIN. BORE	DH	L	E	L1	T	SETSCREW						
55	1	2.156	.787	4.72	6.30	1.18	2.56	.79	M10						
	1a	2.750	2.165												

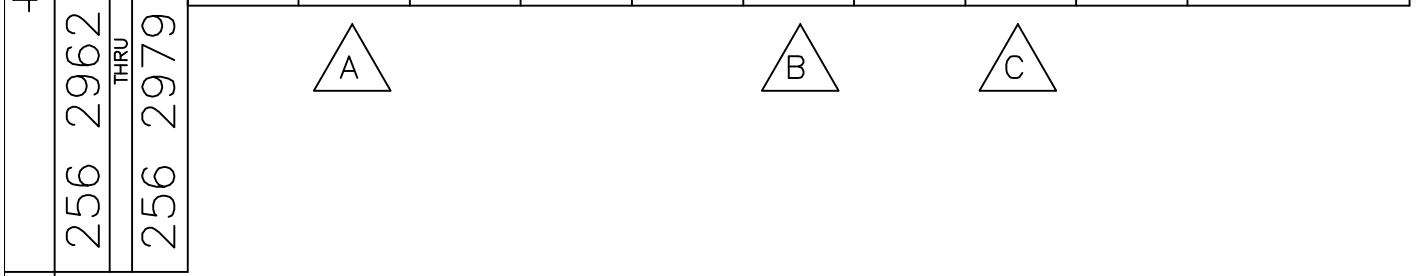

CPLG SIZE	BORE	KEYSEAT		J +.005 -.005	W +.002 -.000	PART NO.
		STANDARD	SPECIAL			
55						2962
	1.063	1/4x1/8	-	1.183	.250	2963
	1.125	1/4x1/8	-	1.246	.250	2964
	1.250	1/4x1/8	-	1.372	.250	2965
	1.375	5/16x5/32	-	1.523	.313	2966
	1.375	-	3/8x3/16	1.546	.375	2967
	1.500	3/8x3/16	-	1.674	.375	2968
	1.625	3/8x3/16	-	1.801	.375	2969
	1.688	3/8x3/16	-	1.864	.375	2970
	1.750	3/8x3/16	-	1.927	.375	2971
	1.875	1/2x1/4	-	2.101	.500	2972
	2.000	1/2x1/4	-	2.228	.500	2973
	2.125	1/2x1/4	-	2.355	.500	2974
	2.250	1/2x1/4	-	2.355	.500	2975
	2.375	5/8x5/16	-	2.656	.625	2976
	2.500	5/8x5/16	-	2.783	.625	2977
2.625	5/8x5/16	-	2.910	.625	2978	
2.750	5/8x5/16	-	3.037	.625	2979	

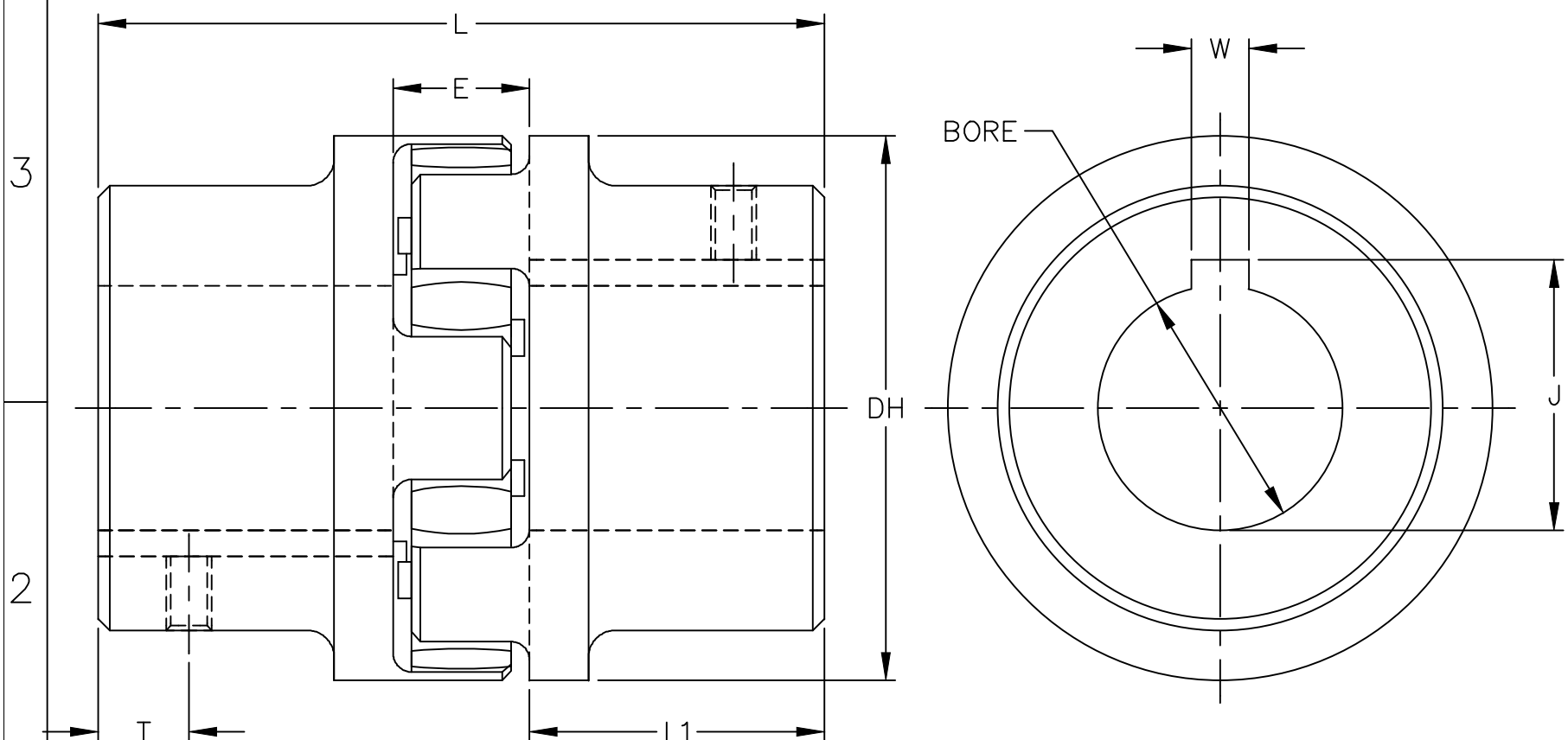

- NOTES:
1. THESE PART NUMBERS ARE FOR COUPLING HUB HALF ONLY. HUBS ARE SUPPLIED STANDARD WITH ONE SET SCREW. INSERT SPIDERS REFERENCE PART NO. 448 1048 000. FOR COMPLETE COUPLING, TWO COUPLING HUBS ARE NEEDED WITH ONE INSERT SPIDER.
 2. KTR CORP. ROTEX 55 CURVE JAW COUPLINGS.
 3. FOR INCH SIZES, BORES TO BE CLEARANCE-FIT. INCH TOLERANCE PER AGMA 9002-A86 CLASS 1 FIT; KEYWAY TOLERANCES PER ANSI B17.1
 4. FOR METRIC SIZES, BORES TO BE CLEARANCE-FIT. METRIC TOLERANCE PER ISO H7 FIT; KEYWAY TOLERANCES PER DIN 6885, Js9
 5. KTR PART DESCRIPTION: ROTEX 55 CAST IRON COUPLING HUB.

THESE BORES PROVIDE A SLIP FIT.

BORE (IN.)	TOLERANCE
UP TO 2.000	+.001 TO -.000
OVER 2.000	+.0015 TO -.000

C 02/18/08 1b - L1 WAS 3.54 JD JD		DO NOT SCALE DRAWING		Pentair Water Pump Division North Aurora Operations
B 02/18/08 1b - L WAS 8.27 JD JD		PLOT SCALE .75 = 1		
A 02/18/08 WAS 1b JD JD		COMPANY CONFIDENTIAL: Information contained herein is confidential, it is the property of Pentair Water. It is to be used solely for the purpose provided, and it is not to be disclosed to others without the prior written consent of Pentair Water.		
REV	DATE	REVISION	BY	CK'D
NOTES: 1. FINISH = 125 RMS. 2. 2 PLACE DECIMALS ± .06. 3. 3 PLACE DECIMALS ± .010. 4. ANGULAR DIMENSIONS ± 1/2°. 5. CHAMF. ALL MACH'D. SURFACE .005-.010x45° AND REMOVE ALL BURRS. 6. ALL PARTS MUST BE FREE FROM SCALE. 7. NO TOLERANCE NEEDED ON REFERENCE DIMENSIONS. 8. ALL BOLT CIRCLE TOLERANCE PER ANSI B16.5. 9. CONCENTRICITY TO CENTERLINE .005.				
DRAWN BY JPD		CURVE JAW TYPE COUPLINGS ROTEX 55 ELASTOMER-IN-COMPRESSION		
DATE 04/25/07		REV C		
CHECKED BY JLF		SIZE		
APPROVED BY JLF		B		
		256 2962 000		
		THRU		
		256 2979 000		

A					B				
CPLG SIZE	HUB DESIGN	MAX. BORE	MIN. BORE	DH	L	E	L1	T	SETSCREW
65	1	2.500	.866	5.31	7.28	1.38	2.95	.79	M10

CPLG SIZE	BORE	KEYSEAT		J +.005 -.005	W +.002 -.000	PART NO.	
		STANDARD	SPECIAL				
65						2980	
						2981	
						2982	
						2983	
	1.125	1/4x1/8	-		1.246	.250	2984
	1.250	1/4x1/8	-		1.372	.250	2985
	1.375	5/16x5/32	-		1.523	.313	2986
	1.375	-	3/8x3/16		1.546	.375	2987
	1.500	3/8x3/16	-		1.674	.375	2988
	1.625	3/8x3/16	-		1.801	.375	2989
	1.688	3/8x3/16	-		1.864	.375	2990
	1.750	3/8x3/16	-		1.927	.375	2991
	1.875	1/2x1/4	-		2.101	.500	2992
	2.000	1/2x1/4	-		2.228	.500	2993
	2.125	1/2x1/4	-		2.355	.500	2994
	2.250	1/2x1/4	-		2.355	.500	2995
2.375	5/8x5/16	-		2.656	.625	2996	
2.500	5/8x5/16	-		2.783	.625	2997	

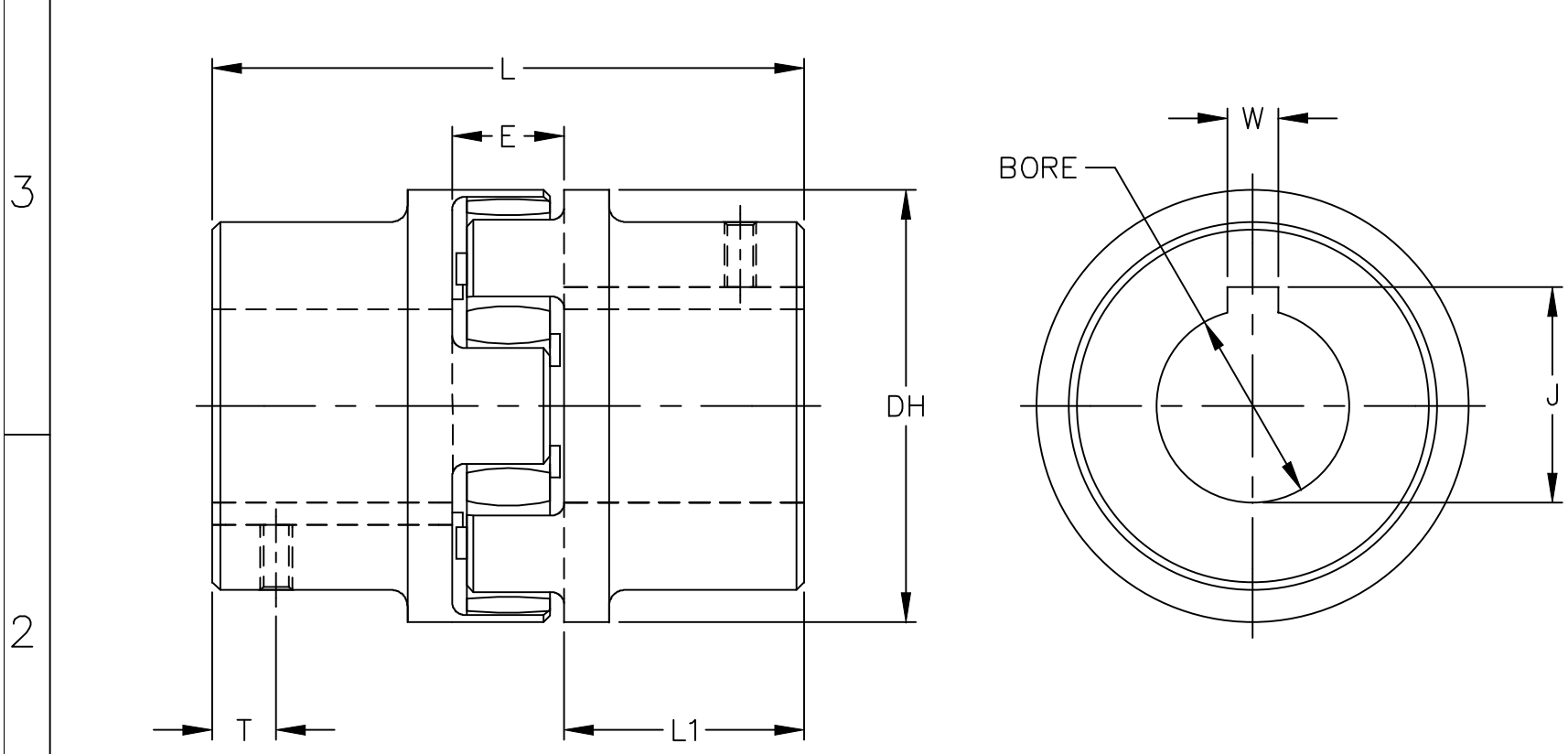

- NOTES:
1. THESE PART NUMBERS ARE FOR COUPLING HUB HALF ONLY. HUBS ARE SUPPLIED STANDARD WITH ONE SET SCREW. INSERT SPIDERS REFERENCE PART NO. 448 1049 000. FOR COMPLETE COUPLING, TWO COUPLING HUBS ARE NEEDED WITH ONE INSERT SPIDER.
 2. KTR CORP. ROTEX 65 CURVE JAW COUPLINGS.
 3. FOR INCH SIZES, BORES TO BE CLEARANCE-FIT. INCH TOLERANCE PER AGMA 9002-A86 CLASS 1 FIT; KEYWAY TOLERANCES PER ANSI B17.1
 4. FOR METRIC SIZES, BORES TO BE CLEARANCE-FIT. METRIC TOLERANCE PER ISO H7 FIT; KEYWAY TOLERANCES PER DIN 6885, Js9
 5. KTR PART DESCRIPTION: ROTEX 65 CAST IRON COUPLING HUB.

THESE BORES PROVIDE A SLIP FIT.

BORE (IN.)	TOLERANCE
UP TO 2.000	+.001 TO -.000
OVER 2.000	+.0015 TO -.000

					DO NOT SCALE DRAWING	Pentair Water	Pump Division North Aurora Operations
					PLOT SCALE .50 = 1		
					COMPANY CONFIDENTIAL: Information contained herein is confidential, it is the property of Pentair Water. It is to be used solely for the purpose provided, and it is not to be disclosed to others without the prior written consent of Pentair Water.		
REV	DATE	REVISION	BY	CK'D	NOTES:	DRAWN BY	CURVE JAW TYPE COUPLINGS ROTEX 65 ELASTOMER-IN-COMPRESSION
					1. FINISH = 125 RMS. 2. 2 PLACE DECIMALS ± .06. 3. 3 PLACE DECIMALS ± .010. 4. ANGULAR DIMENSIONS ± 1/2°. 5. CHAMF. ALL MACH'D. SURFACE .005-.010x45° AND REMOVE ALL BURRS. 6. ALL PARTS MUST BE FREE FROM SCALE. 7. NO TOLERANCE NEEDED ON REFERENCE DIMENSIONS. 8. ALL BOLT CIRCLE TOLERANCE PER ANSI B16.5. 9. CONCENTRICITY TO CENTERLINE .005.	JPD	REV -
					STANDARD TOLERANCES UNLESS OTHERWISE SPECIFIED.	DATE	256 2980 000
						04/25/07	THRU
						CHECKED BY	256 2997 000
						JLF	
						APPROVED BY	
						JLF	

A					B				
CPLG SIZE	HUB DESIGN	MAX. BORE	MIN. BORE	DH	L	E	L1	T	SETSCREW
75	1	3.750	---	6.30	8.27	1.57	3.35	.98	M10

CPLG SIZE	BORE	KEYSEAT		J +.005 -.005	W +.002 -.000	PART NO.
		STANDARD	SPECIAL			
75	1.375	5/16x5/32	-	1.523	.313	2998
	1.375	-	3/8x3/16	1.546	.375	2999
	1.500	3/8x3/16	-	1.674	.375	3000
	1.625	3/8x3/16	-	1.801	.375	3001
	1.688	3/8x3/16	-	1.864	.375	3002
	1.750	3/8x3/16	-	1.927	.375	3003
	1.875	1/2x1/4	-	2.101	.500	3004
	2.000	1/2x1/4	-	2.228	.500	3005
	2.125	1/2x1/4	-	2.355	.500	3006
	2.250	1/2x1/4	-	2.355	.500	3007
	2.375	5/8x5/16	-	2.656	.625	3008
	2.500	5/8x5/16	-	2.783	.625	3009
	2.625	5/8x5/16	-	2.910	.625	3010
	2.750	5/8x5/16	-	3.037	.625	3011
	2.875	3/4x3/8	-	3.210	.750	3012
	3.375	7/8x7/16	-	3.765	.875	3013
3.500	7/8x7/16	-	3.892	.875	3014	
3.750	7/8x7/16	-	4.136	.875	3015	

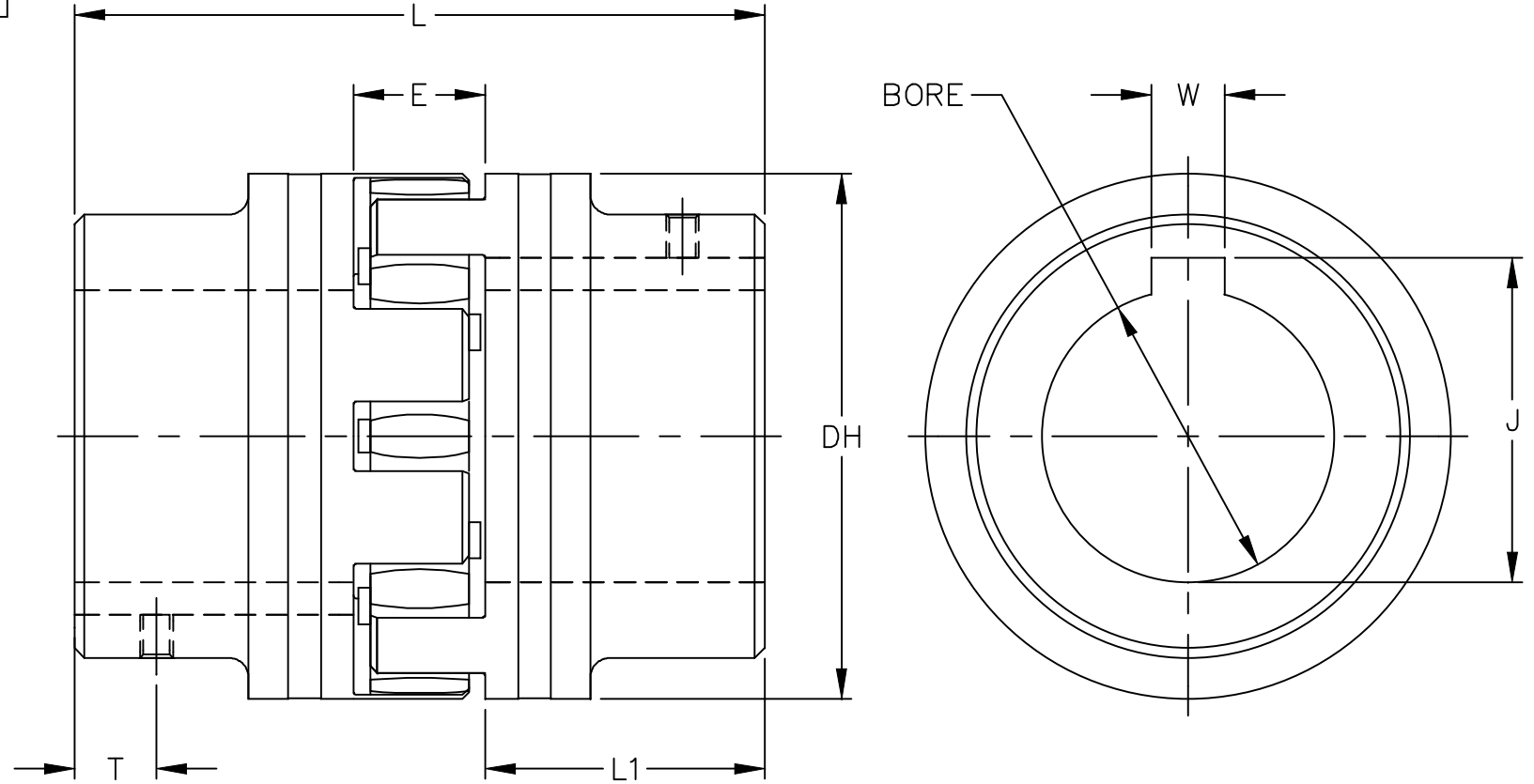

- NOTES:
1. THESE PART NUMBERS ARE FOR COUPLING HUB HALF ONLY. HUBS ARE SUPPLIED STANDARD WITH ONE SET SCREW. INSERT SPIDERS REFERENCE PART NO. 448 1050 000. FOR COMPLETE COUPLING, TWO COUPLING HUBS ARE NEEDED WITH ONE INSERT SPIDER.
 2. KTR CORP. ROTEX 75 CURVE JAW COUPLINGS.
 3. FOR INCH SIZES, BORES TO BE CLEARANCE-FIT. INCH TOLERANCE PER AGMA 9002-A86 CLASS 1 FIT; KEYWAY TOLERANCES PER ANSI B17.1
 4. FOR METRIC SIZES, BORES TO BE CLEARANCE-FIT. METRIC TOLERANCE PER ISO H7 FIT; KEYWAY TOLERANCES PER DIN 6885, Js9
 5. KTR PART DESCRIPTION: ROTEX 75 MACHINED STEEL COUPLING HUB.

THESE BORES PROVIDE A SLIP FIT.

BORE (IN.)	TOLERANCE
UP TO 2.000	+.001 TO -.000
OVER 2.000	+.0015 TO -.000

DO NOT SCALE DRAWING PLOT SCALE .50 = 1					Pentair Water Pump Division North Aurora Operations	
COMPANY CONFIDENTIAL: Information contained herein is confidential, it is the property of Pentair Water. It is to be used solely for the purpose provided, and it is not to be disclosed to others without the prior written consent of Pentair Water.						
REV	DATE	REVISION	BY	CK'D	DRAWN BY JPD DATE 04/25/07 CHECKED BY JLF APPROVED BY JLF	CURVE JAW TYPE COUPLINGS ROTEX 75 ELASTOMER-IN-COMPRESSION REV - 256 2998 000 SIZE B THRU 256 3015 000
NOTES: 1. FINISH = 125 RMS. 2. 2 PLACE DECIMALS ± .06. 3. 3 PLACE DECIMALS ± .010. 4. ANGULAR DIMENSIONS ± 1/2°. 5. CHAMF. ALL MACH'D. SURFACE .005-.010x45° AND REMOVE ALL BURRS. 6. ALL PARTS MUST BE FREE FROM SCALE. 7. NO TOLERANCE NEEDED ON REFERENCE DIMENSIONS. 8. ALL BOLT CIRCLE TOLERANCE PER ANSI B16.5. 9. CONCENTRICITY TO CENTERLINE .005.					STANDARD TOLERANCES UNLESS OTHERWISE SPECIFIED.	

A					B				
CPLG SIZE	HUB DESIGN	MAX. BORE	MIN. BORE	DH	L	E	L1	T	SETSCREW
90	1	3.500	1.575	7.87	9.65	1.77	3.94	1.18	M12

256 3016 000
 THRU
 256 3033 000

NOTE: MAXIMUM SPEED FOR SIZE 90 COUPLING IS 2800 RPM.

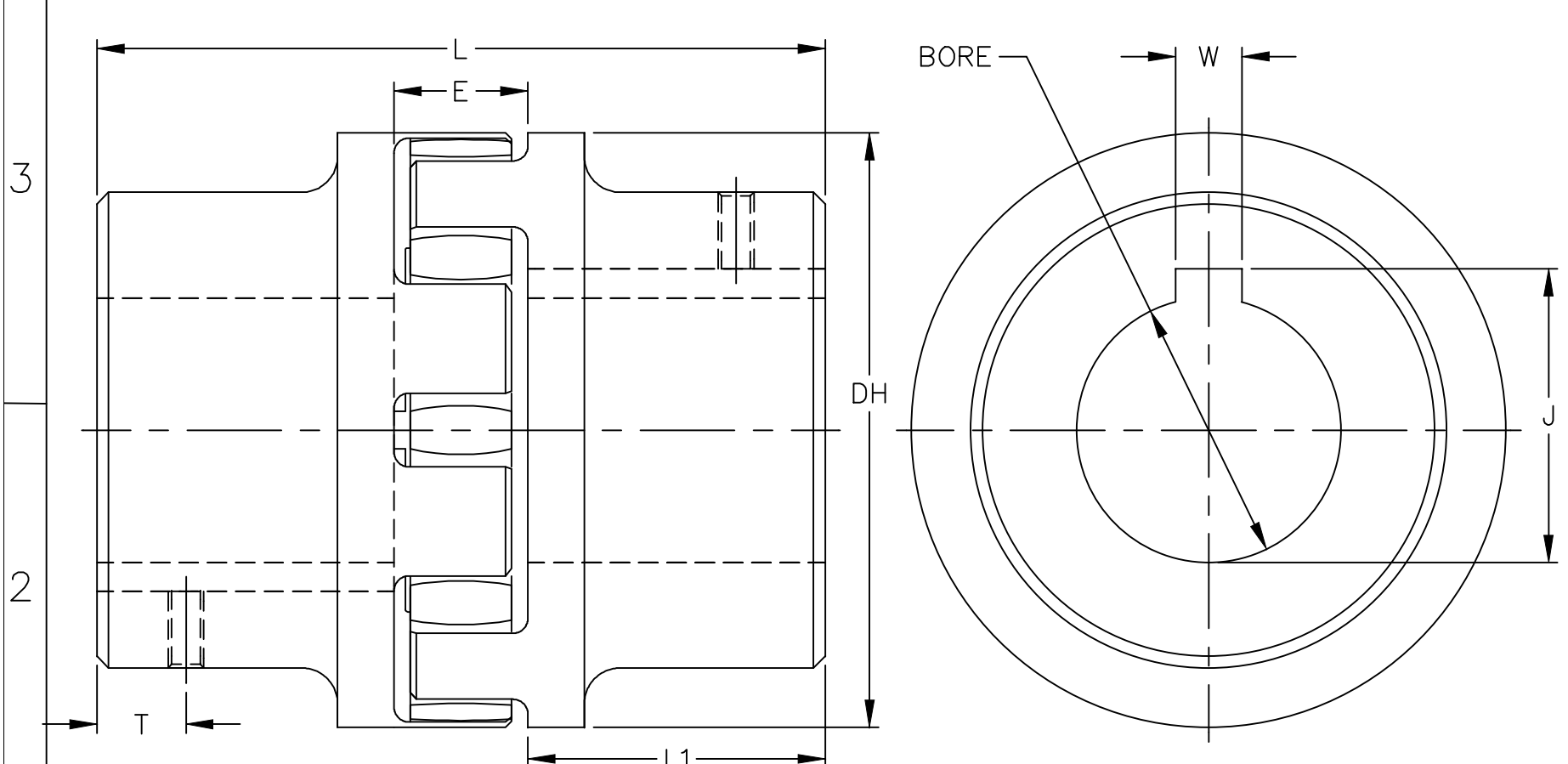

CPLG SIZE	BORE	KEYSEAT		J +.005 -.005	W +.002 -.000	PART NO.
		STANDARD	SPECIAL			
90						3016
						3017
	1.625	3/8x3/16	-	1.801	.375	3018
	1.750	3/8x3/16	-	1.927	.375	3019
	1.875	1/2x1/4	-	2.101	.500	3020
	2.000	1/2x1/4	-	2.228	.500	3021
	2.125	1/2x1/4	-	2.355	.500	3022
	2.250	1/2x1/4	-	2.355	.500	3023
	2.375	5/8x5/16	-	2.656	.625	3024
	2.500	5/8x5/16	-	2.783	.625	3025
	2.625	5/8x5/16	-	2.910	.625	3026
	2.750	5/8x5/16	-	3.037	.625	3027
	2.875	3/4x3/8	-	3.210	.750	3028
	3.000	3/4x3/8	-	3.337	.750	3029
	3.125	3/4x3/8	-	3.454	.750	3030
						3031
	3.375	7/8x7/16	-	3.765	.875	3032
3.500	7/8x7/16	-	3.892	.875	3033	

NOTES:

1. THESE PART NUMBERS ARE FOR COUPLING HUB HALF ONLY. HUBS ARE SUPPLIED STANDARD WITH ONE SET SCREW. INSERT SPIDERS REFERENCE PART NO. 448 1051 000. FOR COMPLETE COUPLING, TWO COUPLING HUBS ARE NEEDED WITH ONE INSERT SPIDER.
2. KTR CORP. ROTEX 90 CURVE JAW COUPLINGS.
3. FOR INCH SIZES, BORES TO BE CLEARANCE-FIT. INCH TOLERANCE PER AGMA 9002-A86 CLASS 1 FIT; KEYWAY TOLERANCES PER ANSI B17.1
4. FOR METRIC SIZES, BORES TO BE CLEARANCE-FIT. METRIC TOLERANCE PER ISO H7 FIT; KEYWAY TOLERANCES PER DIN 6885, Js9
5. KTR PART DESCRIPTION: ROTEX 90 CAST IRON COUPLING HUB.

THESE BORES PROVIDE A SLIP FIT.

BORE (IN.)	TOLERANCE
UP TO 2.000	+.001 TO -.000
OVER 2.000	+.0015 TO -.000

DO NOT SCALE DRAWING PLOT SCALE .50 = 1					Pentair Water Pump Division North Aurora Operations	
COMPANY CONFIDENTIAL: Information contained herein is confidential, it is the property of Pentair Water. It is to be used solely for the purpose provided, and it is not to be disclosed to others without the prior written consent of Pentair Water.						
REV	DATE	REVISION	BY	CK'D	DRAWN BY JPD DATE 04/25/07 CHECKED BY JLF APPROVED BY JLF	CURVE JAW TYPE COUPLINGS ROTEX 90 ELASTOMER-IN-COMPRESSION REV - 256 3016 000 SIZE B THRU 256 3033 000
NOTES: 1. FINISH = 125 RMS. 2. 2 PLACE DECIMALS ± .06. 3. 3 PLACE DECIMALS ± .010. 4. ANGULAR DIMENSIONS ± 1/2°. 5. CHAMF. ALL MACH'D. SURFACE .005-.010x45° AND REMOVE ALL BURRS. 6. ALL PARTS MUST BE FREE FROM SCALE. 7. NO TOLERANCE NEEDED ON REFERENCE DIMENSIONS. 8. ALL BOLT CIRCLE TOLERANCE PER ANSI B16.5. 9. CONCENTRICITY TO CENTERLINE .005.					STANDARD TOLERANCES UNLESS OTHERWISE SPECIFIED.	

A					B				
CPLG SIZE	HUB DESIGN	MAX. BORE	MIN. BORE	DH	L	E	L1	T	SETSCREW
100	1	4.500	1.969	8.86	10.63	1.97	4.33	1.18	M12

NOTE: MAXIMUM SPEED FOR SIZE 100 COUPLING IS 2500 RPM.

256 3034 000
THRU
256 3051 000

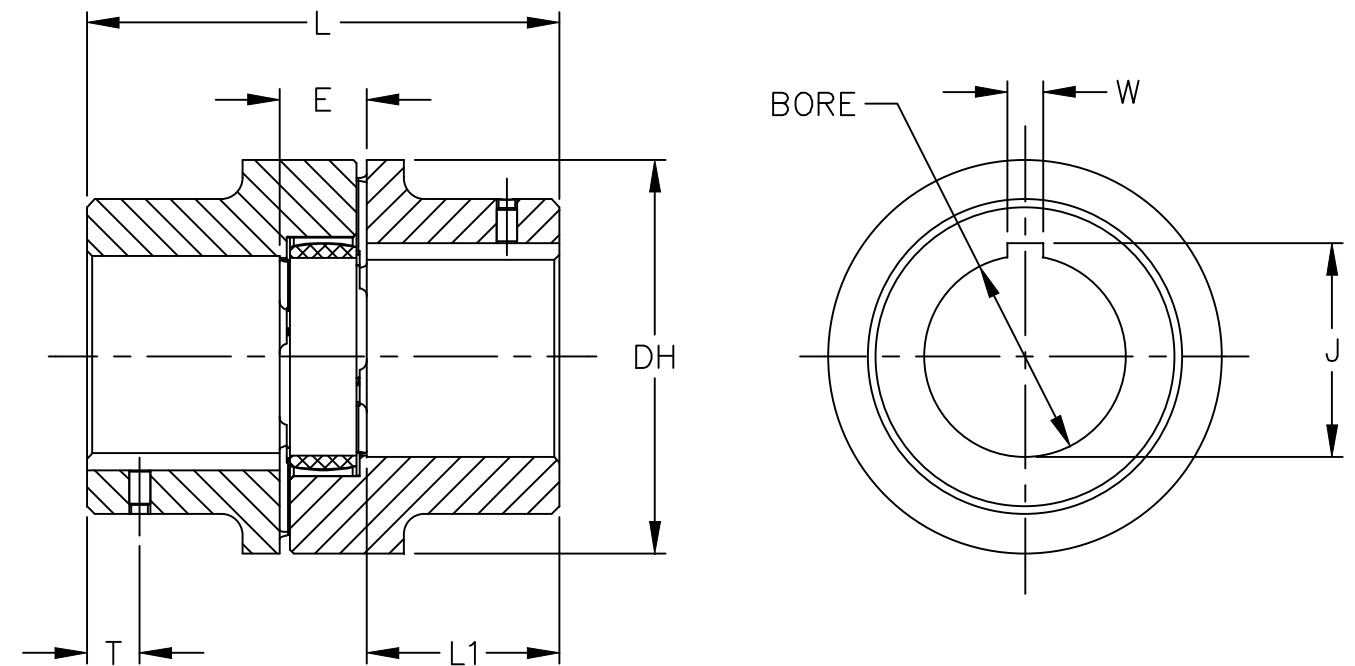

CPLG SIZE	BORE	KEYSEAT		J +.005 -.005	W +.002 -.000	PART NO.
		STANDARD	SPECIAL			
100	2.000	1/2x1/4	-	2.228	.500	3034
	2.125	1/2x1/4	-	2.355	.500	3035
	2.250	1/2x1/4	-	2.355	.500	3036
	2.375	5/8x5/16	-	2.656	.625	3037
	2.500	5/8x5/16	-	2.783	.625	3038
	2.625	5/8x5/16	-	2.910	.625	3039
	2.750	5/8x5/16	-	3.037	.625	3040
	2.875	3/4x3/8	-	3.210	.750	3041
	3.000	3/4x3/8	-	3.337	.750	3042
	3.125	3/4x3/8	-	3.454	.750	3043
	3.375	7/8x7/16	-	3.765	.875	3044
	3.625	7/8x7/16	-	4.019	.875	3045
	3.750	7/8x7/16	-	4.146	.875	3046
	3.875	1x1/2	-	4.319	1.000	3047
	4.125	1x1/2	-	4.573	1.000	3048
	4.250	1x1/2	-	4.700	1.000	3049
	4.375	1x1/2	-	4.827	1.000	3050
					3051	

- NOTES:
1. THESE PART NUMBERS ARE FOR COUPLING HUB HALF ONLY. HUBS ARE SUPPLIED STANDARD WITH ONE SET SCREW. INSERT SPIDERS REFERENCE PART NO. 448 1052 000. FOR COMPLETE COUPLING, TWO COUPLING HUBS ARE NEEDED WITH ONE INSERT SPIDER.
 2. KTR CORP. ROTEX 100 CURVE JAW COUPLINGS.
 3. FOR INCH SIZES, BORES TO BE CLEARANCE-FIT. INCH TOLERANCE PER AGMA 9002-A86 CLASS 1 FIT; KEYWAY TOLERANCES PER ANSI B17.1
 4. FOR METRIC SIZES, BORES TO BE CLEARANCE-FIT. METRIC TOLERANCE PER ISO H7 FIT; KEYWAY TOLERANCES PER DIN 6885, Js9
 5. KTR PART DESCRIPTION: ROTEX 100 NODULAR IRON COUPLING HUB.

THESE BORES PROVIDE A SLIP FIT.

BORE (IN.)	TOLERANCE
UP TO 2.000	+.001 TO -.000
OVER 2.000	+.0015 TO -.000

DO NOT SCALE DRAWING PLOT SCALE .25 = 1					Pentair Water Pump Division North Aurora Operations	
COMPANY CONFIDENTIAL: Information contained herein is confidential, it is the property of Pentair Water. It is to be used solely for the purpose provided, and it is not to be disclosed to others without the prior written consent of Pentair Water.						
REV	DATE	REVISION	BY	CK'D	DRAWN BY JPD DATE 04/25/07 CHECKED BY JLF APPROVED BY JLF	CURVE JAW TYPE COUPLINGS ROTEX 100 ELASTOMER-IN-COMPRESSION REV - 256 3034 000 SIZE B THRU 256 3051 000
NOTES: 1. FINISH = 125 RMS. 2. 2 PLACE DECIMALS ± .06. 3. 3 PLACE DECIMALS ± .010. 4. ANGULAR DIMENSIONS ± 1/2°. 5. CHAMF. ALL MACH'D. SURFACE .005-.010x45° AND REMOVE ALL BURRS. 6. ALL PARTS MUST BE FREE FROM SCALE. 7. NO TOLERANCE NEEDED ON REFERENCE DIMENSIONS. 8. ALL BOLT CIRCLE TOLERANCE PER ANSI B16.5. 9. CONCENTRICITY TO CENTERLINE .005.					STANDARD TOLERANCES UNLESS OTHERWISE SPECIFIED.	

A					B				
CPLG SIZE	HUB DESIGN	MAX. BORE	MIN. BORE	DH	L	E	L1	T	SETSCREW
110	1	4.875	2.362	10.04	11.61	2.17	4.72	1.38	M16

NOTE: MAXIMUM SPEED FOR SIZE 110 COUPLING IS 2240 RPM.

256 3052 000
THRU
256 3069 000

4
3
2
1

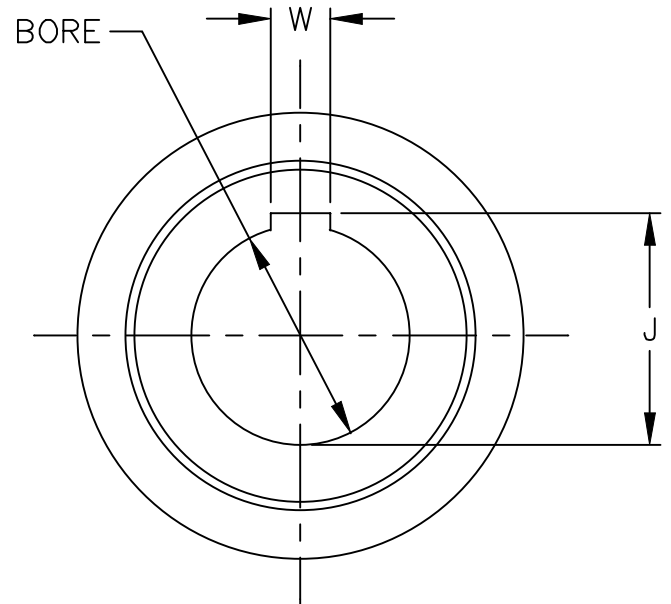
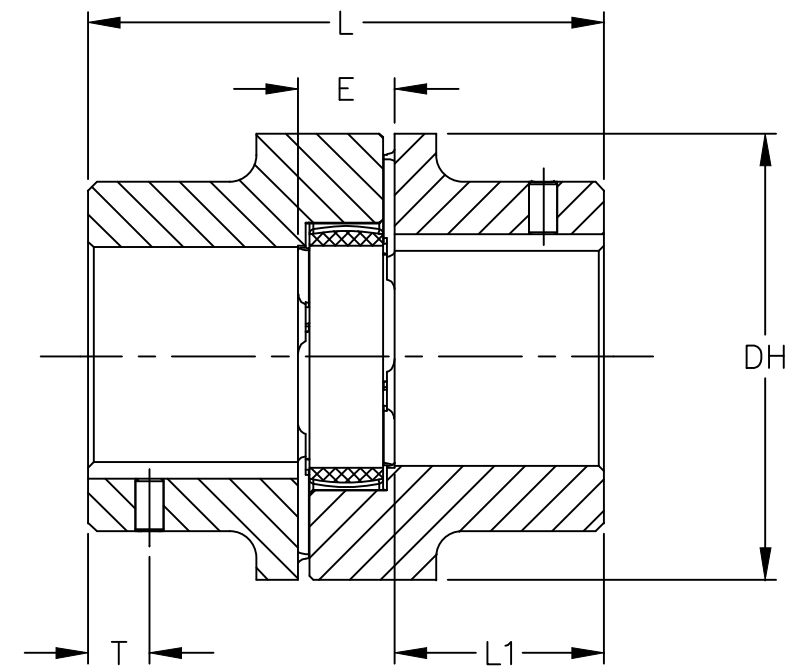

CPLG SIZE	BORE	KEYSEAT		J +.005 -.005	W +.002 -.000	PART NO.
		STANDARD	SPECIAL			
110	2.375	5/8x5/16	—	2.656	.625	3052
	2.500	5/8x5/16	—	2.783	.625	3053
	2.625	5/8x5/16	—	2.910	.625	3054
	2.750	5/8x5/16	—	3.037	.625	3055
	2.875	3/4x3/8	—	3.210	.750	3056
	3.000	3/4x3/8	—	3.337	.750	3057
	3.125	3/4x3/8	—	3.454	.750	3058
	3.375	7/8x7/16	—	3.765	.875	3059
	3.625	7/8x7/16	—	4.019	.875	3060
	3.750	7/8x7/16	—	4.146	.875	3061
	3.875	1x1/2	—	4.319	1.000	3062
	4.125	1x1/2	—	4.573	1.000	3063
	4.250	1x1/2	—	4.700	1.000	3064
	4.375	1x1/2	—	4.827	1.000	3065
	4.875	1 1/4x5/8	—	5.429	1.250	3069

4
3
2
1

- NOTES:
1. THESE PART NUMBERS ARE FOR COUPLING HUB HALF ONLY. HUBS ARE SUPPLIED STANDARD WITH ONE SET SCREW. INSERT SPIDERS REFERENCE PART NO. 448 1053 000. FOR COMPLETE COUPLING, TWO COUPLING HUBS ARE NEEDED WITH ONE INSERT SPIDER.
 2. KTR CORP. ROTEX 110 CURVE JAW COUPLINGS.
 3. FOR INCH SIZES, BORES TO BE CLEARANCE-FIT. INCH TOLERANCE PER AGMA 9002-A86 CLASS 1 FIT; KEYWAY TOLERANCES PER ANSI B17.1
 4. FOR METRIC SIZES, BORES TO BE CLEARANCE-FIT. METRIC TOLERANCE PER ISO H7 FIT; KEYWAY TOLERANCES PER DIN 6885, Js9
 5. KTR PART DESCRIPTION: ROTEX 110 NODULAR IRON COUPLING HUB.

THESE BORES PROVIDE A SLIP FIT.

BORE (IN.)	TOLERANCE
OVER 2.000	+.0015 TO -.000

DO NOT SCALE DRAWING PLOT SCALE .25 = 1					Pentair Water Pump Division North Aurora Operations	
COMPANY CONFIDENTIAL: Information contained herein is confidential, it is the property of Pentair Water. It is to be used solely for the purpose provided, and it is not to be disclosed to others without the prior written consent of Pentair Water.					CURVE JAW TYPE COUPLINGS ROTEX 110 ELASTOMER-IN-COMPRESSION	
REV	DATE	REVISION	BY	CK'D	DRAWN BY JPD	REV -
					DATE 04/25/07	256 3052 000
NOTES: 1. FINISH = 125 RMS. 2. 2 PLACE DECIMALS ± .06. 3. 3 PLACE DECIMALS ± .010. 4. ANGULAR DIMENSIONS ± 1/2°. 5. CHAMF. ALL MACH'D. SURFACE .005-.010x45° AND REMOVE ALL BURRS. 6. ALL PARTS MUST BE FREE FROM SCALE. 7. NO TOLERANCE NEEDED ON REFERENCE DIMENSIONS. 8. ALL BOLT CIRCLE TOLERANCE PER ANSI B16.5. 9. CONCENTRICITY TO CENTERLINE .005.					CHECKED BY JLF	SIZE THRU
					APPROVED BY JLF	B 256 3069 000

A B C D

A					B				
CPLG SIZE	HUB DESIGN	MAX. BORE	MIN. BORE	DH	L	E	L1	T	SETSCREW
125	1	5.688	2.362	11.42	13.39	2.36	5.51	1.57	M16

NOTE: MAXIMUM SPEED FOR SIZE 125 COUPLING IS 2000 RPM.

256 3070 000
THRU
256 3087 000

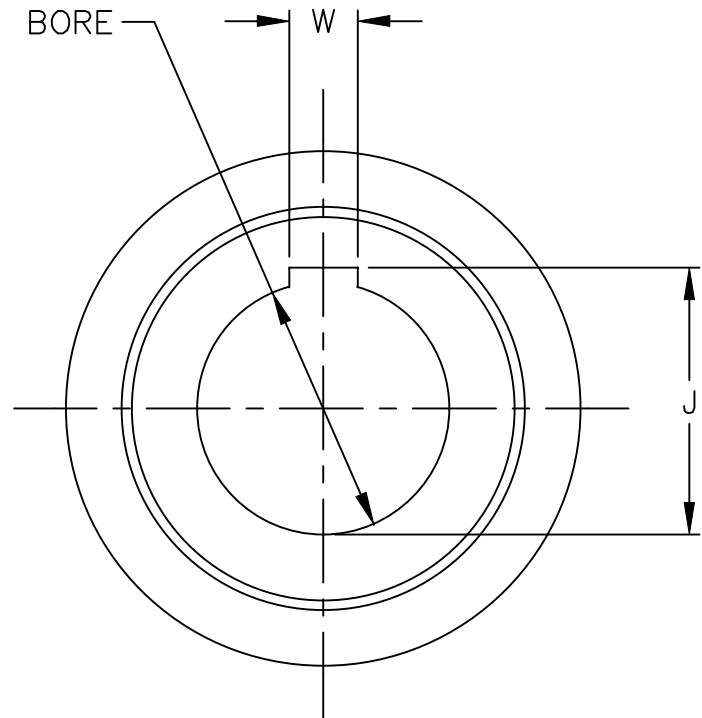
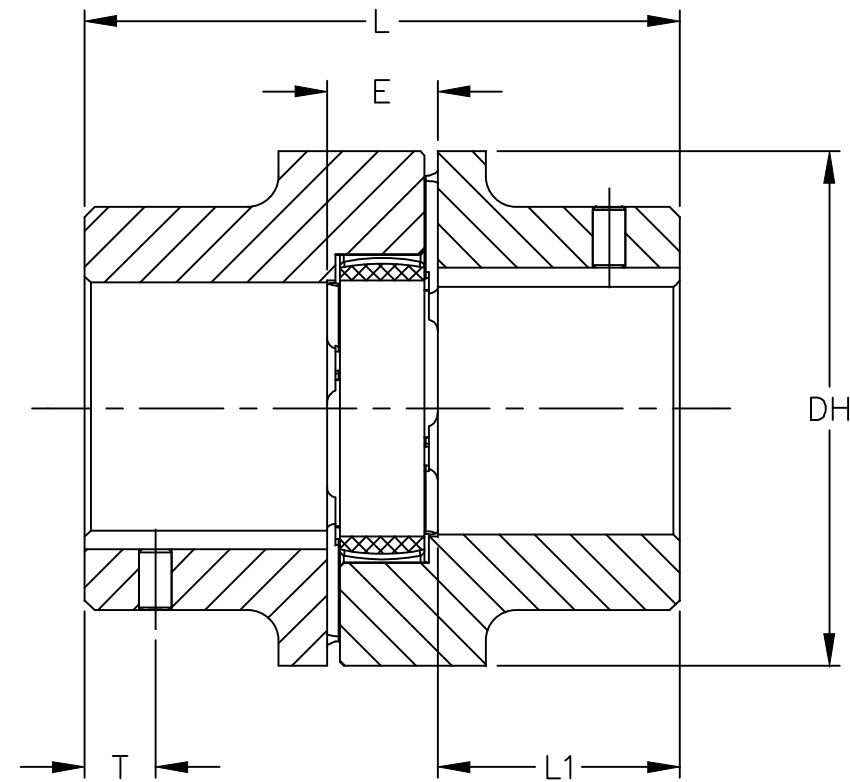

CPLG SIZE	BORE	KEYSEAT		J +.005 -.005	W +.002 -.000	PART NO.
		STANDARD	SPECIAL			
125	2.375	5/8x5/16	-	2.656	.625	3070
	2.500	5/8x5/16	-	2.783	.625	3071
	2.625	5/8x5/16	-	2.910	.625	3072
	2.750	5/8x5/16	-	3.037	.625	3073
	2.875	3/4x3/8	-	3.210	.750	3074
	3.000	3/4x3/8	-	3.337	.750	3075
	3.125	3/4x3/8	-	3.454	.750	3076
	3.375	7/8x7/16	-	3.765	.875	3077
	3.625	7/8x7/16	-	4.019	.875	3078
	3.750	7/8x7/16	-	4.146	.875	3079
	3.875	1x1/2	-	4.319	1.000	3080
	4.125	1x1/2	-	4.573	1.000	3081
	4.250	1x1/2	-	4.700	1.000	3082
	4.375	1x1/2	-	4.827	1.000	3083
						3084
	4.875	1 1/4x5/8	-	5.429	1.250	3085
						3086
					3087	

- NOTES:
1. THESE PART NUMBERS ARE FOR COUPLING HUB HALF ONLY. HUBS ARE SUPPLIED STANDARD WITH ONE SET SCREW. INSERT SPIDERS REFERENCE PART NO. 448 1054 000. FOR COMPLETE COUPLING, TWO COUPLING HUBS ARE NEEDED WITH ONE INSERT SPIDER.
 2. KTR CORP. ROTEX 125 CURVE JAW COUPLINGS.
 3. FOR INCH SIZES, BORES TO BE CLEARANCE-FIT. INCH TOLERANCE PER AGMA 9002-A86 CLASS 1 FIT; KEYWAY TOLERANCES PER ANSI B17.1
 4. FOR METRIC SIZES, BORES TO BE CLEARANCE-FIT. METRIC TOLERANCE PER ISO H7 FIT; KEYWAY TOLERANCES PER DIN 6885, Js9
 5. KTR PART DESCRIPTION: ROTEX 125 NODULAR IRON COUPLING HUB.

THESE BORES PROVIDE A SLIP FIT.

BORE (IN.)	TOLERANCE
OVER 2.000	+.0015 TO -.000

DO NOT SCALE DRAWING
PLOT SCALE .25 = 1

Pentair Water Pump Division
North Aurora Operations

COMPANY CONFIDENTIAL: Information contained herein is confidential, it is the property of Pentair Water. It is to be used solely for the purpose provided, and it is not to be disclosed to others without the prior written consent of Pentair Water.

REV	DATE	REVISION	BY	CK'D

NOTES:
1. FINISH = 125 RMS.
2. 2 PLACE DECIMALS ± .06.
3. 3 PLACE DECIMALS ± .010.
4. ANGULAR DIMENSIONS ± 1/2°.
5. CHAMF. ALL MACH'D. SURFACE .005-.010x45° AND REMOVE ALL BURRS.
6. ALL PARTS MUST BE FREE FROM SCALE.
7. NO TOLERANCE NEEDED ON REFERENCE DIMENSIONS.
8. ALL BOLT CIRCLE TOLERANCE PER ANSI B16.5.
9. CONCENTRICITY TO CENTERLINE .005.

DRAWN BY	DATE	CHECKED BY	APPROVED BY
JPD	04/25/07	JLF	JLF

CURVE JAW TYPE COUPLINGS ROTEX 125 ELASTOMER-IN-COMPRESSION

REV	SIZE	PART NO.
-	B	256 3070 000
		THRU
		256 3087 000