

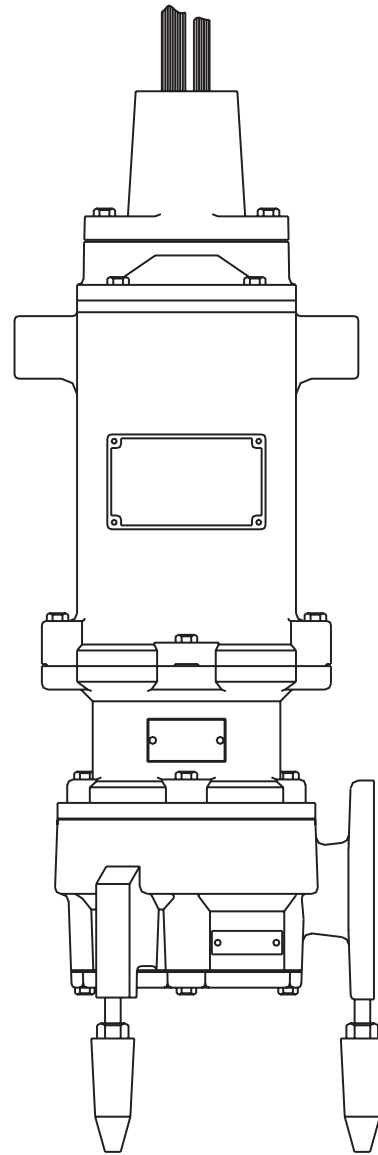

MYERS®



MODELS WGX30/50, WGX30H/50H/75H, V SX30/50 and VHX30/50/75

Hazardous Locations Class I, Division 1, Groups C & D

SUBMERSIBLE GRINDER PUMPS

INSTALLATION AND SERVICE MANUAL

For use with product built with RBC motor.

NOTE! To the installer: Please make sure you provide this manual to the owner of the equipment or to the responsible party who maintains the system.



(*Hazardous Location
Motor End)



APPROVED

CAUTION!

Read these safety warnings first before installing, servicing or operating any pump.

CALIFORNIA PROPOSITION 65 WARNING:

▲ WARNING This product and related accessories contain chemicals known to the State of California to cause cancer, birth defects or other reproductive harm.

GENERAL

1. Most accidents can be avoided by using common sense.
2. Read the operation and maintenance instruction manual supplied with the pump.
3. Do not wear loose clothing that can become entangled in the impeller or other moving parts.
4. This pump is designed to handle materials which could cause illness or disease through direct exposure.
Wear adequate protective clothing when working on the pump or piping.

ELECTRICAL

5. To reduce the risk of electrical shock, pump must be properly grounded in accordance with the National Electric Code and all applicable state and local codes and ordinances.
6. To reduce risk of electrical shock, disconnect the pump from the power source before handling or servicing.
7. Any wiring to be done on pumps should be done by a qualified electrician.
8. Never operate a pump with a power cord that has frayed or brittle insulation.
9. Never let cords or plugs lay in water.
10. Never handle connected power cords with wet hands.

PUMPS

11. Pump builds up heat and pressure during operation, allow time for pump to cool before handling or servicing.
12. Only qualified personnel should install, operate or repair pump.
13. Keep clear of suction and discharge openings. Do not insert fingers into pump with power connected.
14. Do not pump hazardous material not recommended for pump (flammable, caustic, etc.).
15. Make sure lifting handles are securely fastened each time before lifting.
16. Do not lift pump by the power cord.
17. Do not exceed manufacturer's recommendation for maximum performance, as this could cause the motor to overheat.

18. Secure the pump in its operating position so it cannot tip over, fall or slide.
19. Keep hands and feet away from impeller when power is connected.
20. Submersible solids handling pumps are not approved for use in swimming pools, recreational water installations, decorative fountains or any installation where human contact with the pumped fluid is common.
21. Do not operate pump without safety devices in place.

IMPORTANT! Myers® is not responsible for losses, injury or death resulting from a failure to observe these safety precautions, misuse or abuse of pumps or equipment.

GENERAL INFORMATION

Pump Models: These instructions cover the installation and service of the Myers pumps as listed on the front cover. The hazardous location models are Factory Mutual approved and listed hazardous location for hazardous sewage locations Class I, Division 1, Groups C & D.

Motor HP & Voltages: These pumps are offered in a three phase wiring configuration only. Voltages will vary according to the application.

Electrical Controls: All of these pump models must be used with a control panel. Myers-built control panels are designed to supply the correct electrical controls, motor starting equipment and include the circuitry for moisture and heat sensors. It is recommended that a Myers-built control panel be used so that all warranties apply.

General Construction: The motor construction is designed to meet Factory Mutual's requirements for Class I, Division 1, Groups C & D sewage applications. The hazardous location models are certified and nameplated with this approval. The motor chamber and seal chamber are filled with a high dielectric type oil for improved lubrication and heat transfer of the bearings and motor. Since the bearings have been designed for 50,000 hours of life, the oil should never require replacement under normal operating conditions. An air space above the oil level in both the seal and motor chambers is provided to allow for the expansion of the oil when at operating temperature. The power and control lines are sealed and strain relieved by a grommet in the cord cap, and internally through the use of a dielectric potting resin surrounding the electrical wires. All of the pump fasteners and shafts are made from corrosion resistant stainless steel, while the pump castings are made of ASTM A-48 Class 30 cast iron.

Hazardous Location Service: These pumps are to be used for handling sewage, wastewater and storm water only. Do not use in other hazardous locations. These pumps must be repaired and serviced only at Myers authorized service centers or at the Myers factory. Any unauthorized field repair voids warranty, hazardous location rating and Factory Mutual approval.

CAUTION: After the pump is installed and sewage has entered the basin there are methane and hydrogen sulfide gases, which are poisonous. Never enter a wet well unless the cover is open for a sufficient period of time to allow fresh air into the basin. Myers recommends using the rail lift-out system so that no service is required inside the basin.

Motor: Each motor is provided with heat sensor thermostats attached directly to the motor windings. The thermostats open if the motor windings see excessive heat and, in turn, open the motor contractor in the control panel, breaking the power to the pump. When the motor is stopped due to an overheated condition, it will not start until the motor has cooled and the heat sensor reset button is manually pushed on the front of the Myers control panel. This circuitry is provided in the Myers control panel designs.

The thermostats are set to open at a temperature of 248°F (120°C). The maximum contact rating is 18 amps at 115 VAC and 12 amps at 230 VAC. Motor winding insulation is good for Class F (311°F, 155°C).

Note: Failure to use proper circuitry and to connect the motor overheat protection in the control panel would negate all warranties and FM approval.

Motor Seal Failure Warning: The seal chamber is oil filled and provided with moisture sensing probes to detect water leakage through the lower shaft seal. The probes can also detect moisture present in the upper motor housing.

The presence of water energizes a red seal leak warning light at the control panel. This is a *warning light only*, and does not stop the motor. It indicates a leak has occurred and the pump must be repaired. Normally, this indicates the outboard seal has leaked. Allowing the unit to operate after the warning could cause upper seal leakage along with motor failure.

The resistance across the moisture sensing (seal failure) probes, should be checked after a seal leak warning light has lit. This can be done by disconnecting the red and orange control wires from the control panel, and measuring the resistance with an ohmmeter between the wires. If the measured values are below specification, then the pump may have a lower seal failure and require service.

On the Myers hazardous location control panels the seal leak test switch tests the seal leak circuit continuity. When pushed, the seal leak test bulb should light. If the test bulb does not light, it means either the wiring circuitry to the seal leak probes has been broken or the bulb has burned out.

Note: Myers-built control panels supply the correct circuitry for moisture and heat sensor connections. Failure to install the correct circuitry with proper connection would negate warranty and FM approval.

Motor Power Cord, Control Cord and Cord Cap Assembly:

Each motor power cord has 4 conductors – white, black, red and green. For a three phase motor the red, black and white conductors connect to the three line leads, and the green is connected to a good ground. Interchanging any two line leads will reverse the rotation of the motor.

Note: Rotation should be clockwise when observed from the top of the pump. This can be checked by noting which direction the pump torque is up on initial starting. A properly rotating pump will torque counterclockwise upon start.

The control cable has 5 conductors – black, white, red, orange and green. White and black connect to the heat sensor terminals in the control panels; red and orange connect to the seal failure terminals in the control panel; and the green connects to the ground in the control panel.

The cord cap is epoxy potted. The cord cap provides for a sealed wire connection. This allows the cord cap, with cords, to be removed from the motor. An approved hazardous location junction box is required for hazardous locations. *The control and power cables cannot be spliced!*

Note: Each cable has a green ground wire and must be properly grounded per the National Electric Code and local codes.

Electrical Motor Controls: All electrical controls and motor starting equipment should be as specified in these instructions. Consult factory for any acceptable alternates. For hazardous locations the controls and control panel must be installed outside the hazardous area, or approved hazardous location controls that are intrinsically safe must be used.

Junction Box: If a junction box is used in a hazardous location, it must be a hazardous location approved type with hazardous location cord connectors. Wires from the junction box must pass through a hazardous location seal connector.

Level Sensing Controls: Intrinsically safe-type float controls are recommended for all applications and required for hazardous location service. An intrinsically safe control panel relay will limit the current and voltage to the level controls. A Myers control panel can be supplied with this type circuitry.

The float level controls maintain the basin sewage water level by controlling pump turn-on and turn-off levels.

1. The lower turn-off control should be set so that the pump stops at approximately the top of the pump. Consult the factory for any settings below this point.
2. The upper turn-on control should be set above the lower turn-off control. The exact height between the two controls is determined by the number of pump starts desired and the depth of the basin. A maximum of 10 starts per hour should not be exceeded.
3. The override control is set at a specified height above the upper turn-on control.
4. The alarm control is set about 6" to 12" above the override control.
5. No control should be set above the inlet invert.

Electrical Connections: All electrical wiring must be in accordance with local code and only qualified electricians should make the installations. All wires should be checked for shorts to ground with an ohmmeter or megger after the connections are made. This is important, as one grounded wire can cause failure of the pump, control panel or personal injury.

WARNING: Disconnect pump from power source before servicing or handling pump.

REPLACING GRINDER COMPONENTS

This is the only disassembly operation allowed in the field. All other repairs must be done at the factory or at an authorized service facility.

IMPORTANT! Pump should be thoroughly cleaned of trash and deposits before starting disassembly operations.

CAUTION: DISCONNECT ALL POWER AND CONTROL

WIRES TO MOTOR AT CONTROL PANEL BEFORE STARTING DISASSEMBLY OPERATIONS. NEVER RELY ON OPENING CIRCUIT BREAKER ONLY.

DISASSEMBLY OF STATIONARY CUTTER PLATE AND ROTATING CUTTER: VS and VH SERIES

1. Remove retaining washer and screw from end of shaft. A screwdriver can be used to hold the shaft in place by wedging it between one of the four socket head cap screws and the rotating cutter while loosening the screw.
2. Using a rubber mallet, or soft metal hammer, bump rotating cutter in counterclockwise direction as thread is right-hand. Unthread rotating cutter from shaft. Be careful to not lose ring shims that space the rotating cutter from the stationary cutter plate.
3. Remove four socket head cap screws holding the stationary cutter plate to the volute. Remove stationary cutter from volute. If stationary cutter is stuck, the socket head cap screws can be threaded into tapped back-off holes in plate. Tighten screws to remove plate from volute.
4. Inspect rotating cutter and stationary cutter plate for wear and replace if worn.
5. Make sure pocket in volute is clean and reinstall stationary cutter plate using the four socket head cap screws. Apply blue Loctite® to the threads. Do not over-tighten cap screws.
6. Replace ring shims (if removed from the shaft) and thread rotating cutter onto shaft. Make sure threads on shaft are clean and use Never-Seez® or other graphite compound on threads before replacing rotating cutter.
7. Using a rubber mallet, or soft metal hammer, bump rotating cutter in clockwise direction to make sure it is seated on the impeller.
8. To ensure proper operation of the cutter mechanism, the gap between the stationary cutter plate and rotating cutter must be no more than .010". To check the gap use a .010" feeler gauge. If the .010" feeler gauge does not fit between the surface of the stationary cutter and rotating cutter and the motor shaft turns freely, the gap is set correctly. If the .010" feeler gauge fits between the surfaces, shims must be removed to close the gap.
9. Replace retaining washer and screw in the end of the shaft. Be sure screw is tight. A screwdriver can be used to hold the shaft in place by wedging it between one of the four socket head cap screws and the rotating cutter while tightening the screw.
10. Be sure shaft turns freely after reassembly. Some drag will occur due to the seal, but there should be no binding or tight spots when turning the rotating cutter.
11. If rotating cutter rubs or drags on stationary cutter plate, recheck gap and re-shim rotating cutter.

REPLACING GRINDER IMPELLER AND GRINDER SHREDDING RING: WG AND WGH SERIES

1. Remove screws from holding ring and remove ring.
2. Use two screwdrivers, one each on opposite sides of ring, and pry off snap ring that holds shredding ring in place. Remove shredding ring.
3. Hold impeller by prying against impeller cutting bar and remove cap screw from end of shaft.
4. Use large screwdriver in slot in end of shaft and bump on cutter vane with plastic hammer. Bump in counterclockwise direction as thread is right hand. It may take several bumps to loosen impeller.

If impeller cannot be loosened, it will be necessary to take unit to service facility for service. **DON'T CONTINUE TO POUND ON IMPELLER AS IMPELLER AND SHAFT CAN BE DAMAGED.**
5. If impeller comes off easily, clean up and replace if worn.
6. Be sure pump impeller has not loosened when grinder impeller is removed. This can be checked on reassembly of grinder impeller and shredding ring. Tips of impeller cutter vanes should extend about 1/8" below bottom of shredding ring. If more than 1/8" extends below ring it means pump impeller has loosened.

Remove grinder impeller and ring, remove bolts from pump case and remove case. Use back-off screws in motor mounting plate to pry loose from pump case.
7. After case is removed, wrap emery paper around shaft and hold with vise grip pliers. Use cloth on impeller and screw up against shroud. Now pump can be reassembled.
8. Clean all threads with wire brush and file smooth any threads that may be nicked.
9. Use graphite compound on threads before replacing grinder impeller.
10. Be sure cap screw in bottom of shaft is tight. Hold impeller with screwdriver between cutter bar and teeth of shredding ring while tightening cap screw.
11. Be sure impeller turns free by hand after reassembly. Some drag will occur due to seals but there should be no binding or tight spots when turning the grinder impeller.
12. ALWAYS use a rag on the impellers when turning to prevent cutting hands on the sharp corners of shredding ring.

WIRING DIAGRAMS

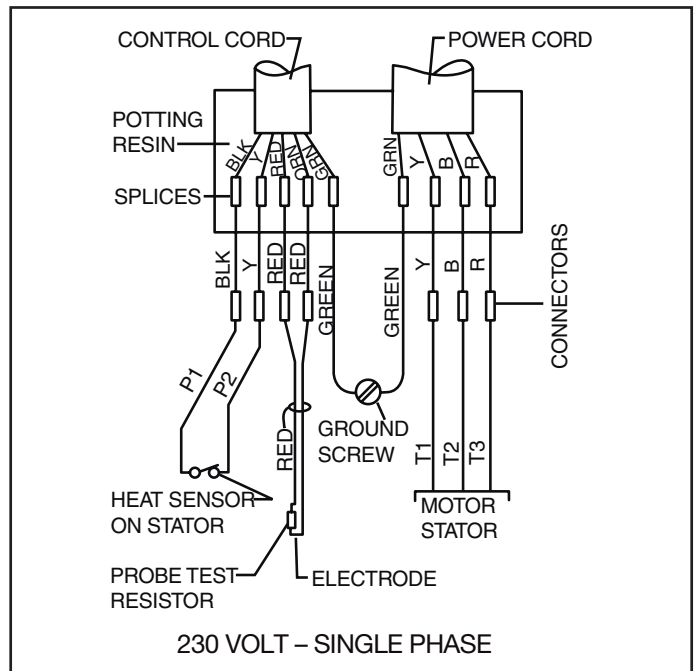
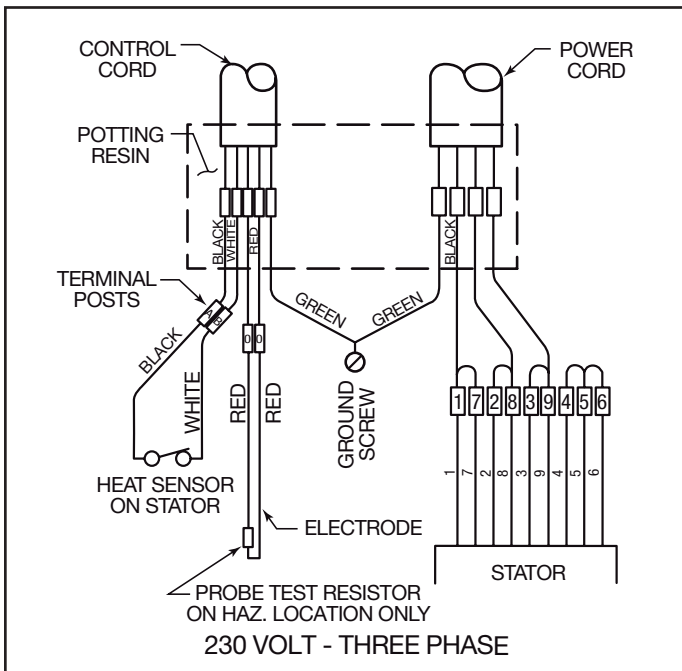
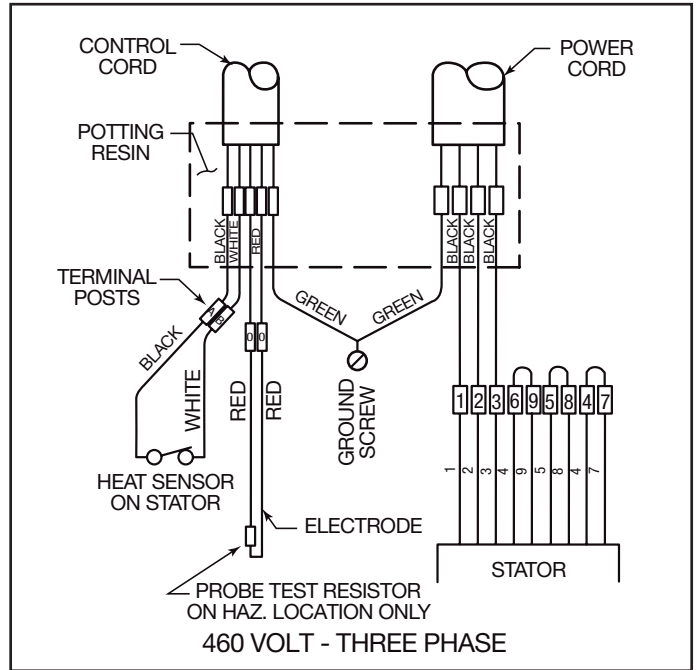
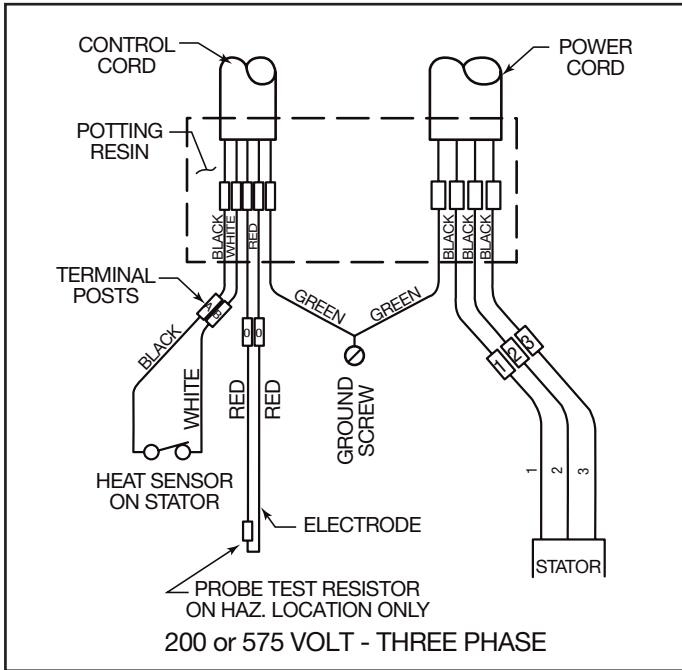

WET END PARTS

WGX30/WGX50

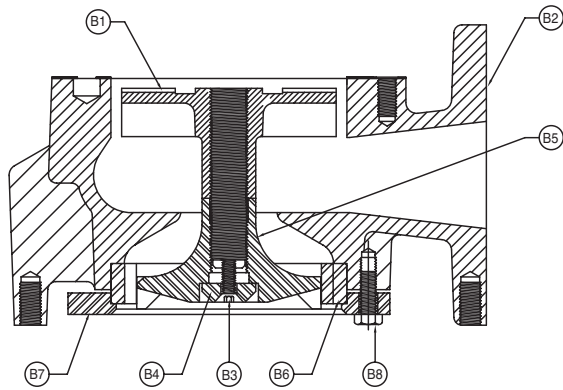

WGX30H/WGX50H/WGX75H

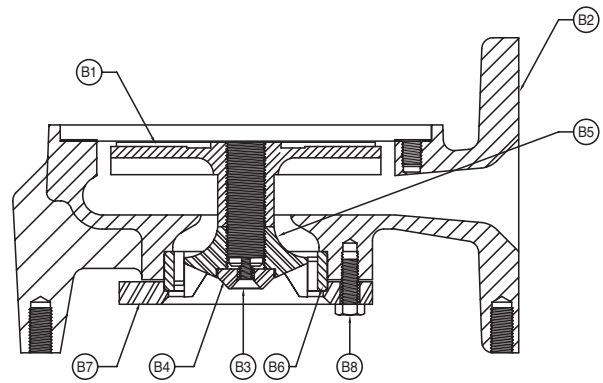

WET END PARTS CHARTS

Item	Description	Eng. No.	Qty.
B2	CASE; VOLUTE	22582D000	1
B3	SCREW; MACH FLT HD HEX SKT SST 5/16-18 UNC-3A x 1-1/4 LG	07597A021	1
B4	RETAINER; IMPELLER 5 HP GRINDER SST	22585A000	1
B5	IMPELLER; GRINDER SST 5 HP LOW HEAD	22584C000	1
B6	RING; SHREDDING SST 5 HP LOW HEAD	22586B000	1
B7	CLAMP; SHREDDING RING 5 HP GRIND PUMP DUCTILE IRON 64-45-12	22587C000	1
B8	SCREW; CAP HEX SST 3/8-16 x 1 LG	19101A010	4

Item	Description	Eng. No.	Qty.
B2	CASE; VOLUTE 5 HP	22639D000	1
B3	SCREW; MACH FLT HD HEX SKT SST 5/16-18 UNC-3A x 1-1/4LG	07597A021	1
B4	RETAINER; IMPELLER 5 HP GRINDER SST	22585A000	1
B5	IMPELLER; SHREDDING FOR HIGH HEAD GRINDER	26010B000	1
B6	RING; SHREDDING FOR HIGH HEAD GRINDER	25134B000	1
B7	CLAMP; SHREDDING RING 5 HP GRIND PUMP DUCTILE IRON 65-45-12	22643B000	1
B8	SCREW; CAP HEX SST 3/8-16 x 1 LG	19101A010	4

IMPELLER CHARTS (PART B1)

Pump	RPM	HP	Trim	Impeller
WGX30-21	3450	3	4.5	28203B011
WGX30-03	3450	3	4.5	28203B011
WGX30-23	3450	3	4.5	28203B011
WGX30-43	3450	3	4.5	28203B011
WGX30-53	3450	3	4.5	28203B011
WGX50-21	3450	5	5	28203B003
WGX50-03	3450	5	5.25	28203B001
WGX50-23	3450	5	5.25	28203B001
WGX50-43	3450	5	5.25	28203B001
WGX50-53	3450	5	5.25	28203B001

Pump	RPM	HP	Trim	Impeller
WGX30H-21	3450	3	5	28202C017
WGX30H-03	3450	3	5	28202C017
WGX30H-23	3450	3	5	28202C017
WGX30H-43	3450	3	5	28202C017
WGX30H-53	3450	3	5	28202C017
WGX50H-21	3450	5	6	28202C007
WGX50H-03	3450	5	6	28202C007
WGX50H-23	3450	5	6	28202C007
WGX50H-43	3450	5	6	28202C007
WGX50H-53	3450	5	6	28202C007
WGX75H-03	3450	7.5	6.5	28202C005
WGX75H-23	3450	7.5	6.5	28202C005
WGX75H-43	3450	7.5	6.5	28202C005
WGX75H-53	3450	7.5	6.5	28202C005

Note: Standard non-overloading impeller diameters shown.

MOTOR SPECIFIC PARTS LISTS

WGX30H/ WGX50H/ WGX75H

		3 HP		3 HP		5/7.5 HP		5/7.5 HP	
		230/1	200/3	230-460/3	575/3	230/1	200/3	230-460/3	575/3
A1	STATOR	22574C210	22574C211	22574C212	22574C214	22574C200	22574C201	22574C202	22574C204
A2	ROTOR	22636C101	22636C100	22636C100	22636C100	22636C203	22636C202	22636C202	22636C202
A3	BEARING	08565A022	08565A022	08565A022	08565A022	08565A022	08565A022	08565A022	08565A022
A4	BEARING	08565A023	08565A023	08565A023	08565A023	08565A023	08565A023	08565A023	08565A023

WGX30/ WGX50

		3/5 HP		3/5 HP	
		230/1	200/3	230-460/3	575/3
A1	STATOR	22574C200	22574C201	22574C202	22574C204
A2	ROTOR	22572C103	22572C102	22572C102	22572C102
A3	BEARING	08565A022	08565A022	08565A022	08565A022
A4	BEARING	08565A023	08565A023	08565A023	08565A023

CAP SCREW	TORQUE VALUE
3/8-16	20 ft.-lbs.
1/2-13	43 ft.-lbs.
5/8-11	93 ft.-lbs.
3/4-10	128 ft.-lbs.
7/8-14	193 ft.-lbs.

WET END PARTS VSX30/50 AND VHX30/50/75

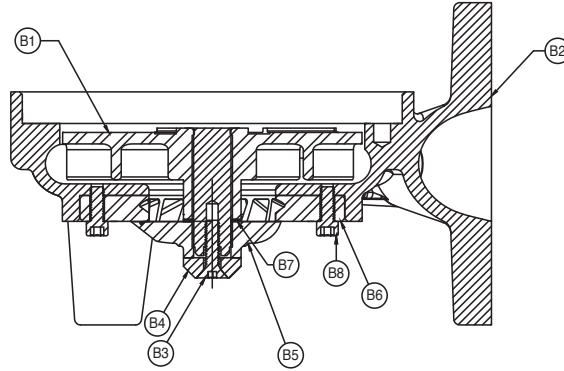

WET END PARTS CHART

Item	Description	Eng. No.	Qty.
B2	CASE; VOLUTE V SERIES GR 56 FRAME	22639D001	1
B3	SCREW; MACH FLT HD HEX SKT SST	07597A021	1
B4	RETAINER; IMPELLER 5HP GRINDER	22585A000	1
B5	CUTTER; ROTATING V SERIES 56 FRAME	28183B000	1
B6	PLATE; STATIONARY CUTTER VH SERIES 56 FRAME	28191B000	1
	PLATE; STATIONARY CUTTER VS SERIES 56 FRAME	28182B000	1
B7	SHIM	006280611	2
	SHIM	006280621	4
B8	SCREW; CAP (HEX SOC) 5/16-18 x 3/4	001780011	4

IMPELLER CHARTS (PART B1)

Pump	RPM	HP	Trim	Impeller
VSX30-21	3450	3	4.25	22640C378
VSX30-03	3450	3	4.25	22640C378
VSX30-23	3450	3	4.25	22640C378
VSX30-43	3450	3	4.25	22640C378
VSX30-53	3450	3	4.25	22640C378
VSX50-21	3450	5	4.75	22640C374
VSX50-03	3450	5	5	22640C372
VSX50-23	3450	5	5	22640C372
VSX50-43	3450	5	5	22640C372
VSX50-53	3450	5	5	22640C372

Pump	RPM	HP	Trim	Impeller
VHX30-21	3450	3	4.25	22640C378
VHX30-03	3450	3	4.5	22640C376
VHX30-23	3450	3	4.5	22640C376
VHX30-43	3450	3	4.5	22640C376
VHX30-53	3450	3	4.5	22640C376
VHX50-21	3450	5	5.38	22640C389
VHX50-03	3450	5	5.38	22640C389
VHX50-23	3450	5	5.38	22640C389
VHX50-43	3450	5	5.38	22640C389
VHX50-53	3450	5	5.38	22640C389
VHX75-03	3450	7.5	5.63	22640C387
VHX75-23	3450	7.5	5.63	22640C387
VHX75-43	3450	7.5	5.63	22640C387
VHX75-53	3450	7.5	5.63	22640C387

MOTOR SPECIFIC PARTS LISTS

VHX30/ VHX50/ VHX75

2 POLE		3 HP	3 HP	3 HP	3 HP	5/7.5 HP	5/7.5 HP	5/7.5 HP	5/7.5 HP
		230/1	200/3	230-460/3	575/1	230/1	200/3	230-460/3	575/1
A1	STATOR	22574C210	22574C211	22574C212	22574C214	22574C200	22574C201	22574C202	22574C204
A2	ROTOR/SHAFT	28208C101	28208C100	28208C100	28208C100	28208C103	28208C102	28208C102	28208C102
A3	BEARING	08565A022	08565A022	08565A022	08565A022	08565A022	08565A022	08565A022	08565A022
A4	BEARING	071670211	071670211	071670211	071670211	071670211	071670211	071670211	071670211

VSX30/ VSX50

2 POLE		3/5 HP	3/5 HP	3/5 HP	3/5 HP
		230/1	200/3	230-460/3	575/1
A1	STATOR	22574C200	22574C201	22574C202	22574C204
A2	ROTOR/SHAFT	28208C103	28208C102	28208C102	28208C102
A3	BEARING	08565A022	08565A022	08565A022	08565A022
A4	BEARING	071670211	071670211	071670211	071670211

MOTOR END PARTS

COMMON PARTS LIST

Item	Eng. No.	Description	Qty.
1	25343A100	PROBE; SEAL LEAK	2
	22912A000	RESISTOR	1
2	05022A092	PLUG; PIPE ST GALV 1/4 HEX HD w/LOCTITE® 513 COATING	2
3	19102A020 (WGX Series)	SCREW; CAP HEX SST 7/16 x 1-1/4 LG	4
	19102A021 (VSX/VHX Series)	SCREW; CAP HEX SST 7/16 x 1-1/4 LG	4
4	05434A043	SCREW; MACH ST 10-24 UNC x 3/8 LG	1
5	05876A112	RING,O; 5-1/2 OD x 5-1/4 ID x 1/8	1
6	22577A000	SEAL; 1-1/4 SHAFT	2
7	22569B702	35' CORD ASSEMBLY 14-4 – WGX30(H), WGX75H	1
	22569B631	35' CORD ASSEMBLY 10-4 – WGX30(H), WGX50(H)	1
	22569B632	35' CORD ASSEMBLY 8-4 SOOW – WGX30(H), WGX50(H), WGX75H	1
	22569B700	35' CORD ASSEMBLY 8-4 W – WGX30, WGX50(H)	1
8	05876A114	RING, O; 7 OD x 6-3/4 ID x 1/8	1
9	05876A123	RING, O; 4-7/8 OD x 4-5/8 ID x 1/8	1
10	06107A015	WASHER; LOCK SHKPRF INTERNAL ST NO 10	1
11	07597A017	SCREW; MACH FLT HD HEX SKT SST 5/16-18 UNC-3A x 1LG	2
12	12672A003	CONNECTOR; BUTT SOLDERLESS 12-10 WIRE	3
13	19102A006	SCREW; CAP HEX 7/16-14 UNC SST 1-1/2	4
14	19102A023	SCREW; CAP HEX SST 302 7/16-14 NC x 2-1/4	4
15	19331A006	WASHER; SPRING FINGER 1.189 ID x 1.830 OD	2
16	22571D000	HOUSING; MOTOR 5 HP GRINDER PUMP CI	1
17	22578A100	WIRE; ELECTRODE FOR 3-20 HP	2
18	22590B000	CAP, BEARING; UPPER 5 HP GRINDER PUMP CI	1

MODEL SPECIFIC PARTS LIST

Item	Description	WGX30/ WGX50	WGX30H/ WGX50H/ WGX75H	VHX30-75/ VSX30-50
19	O-RING	05876A113	05876A113	05876A113
20	SCREW; CAP SKT HD SST 3/8-16 UNC-3A x 1LG	06106A027	06106A028	06106A028
21	RING; RETAINING EXTERNAL SST 1-1/4 SHAFT	12558A008	12558A008	12558A008
22	UPPER SEAL HOUSING	22576D010	22576D010	22576D020
23	LOWER SEAL HOUSING	22580C000	22638C000	22638C000
24	RING; RETAINING INTERNAL	N/A	N/A	07756A015
25	RING; RETAINING EXTERNAL 1.375 SHAFT	N/A	N/A	12558A037

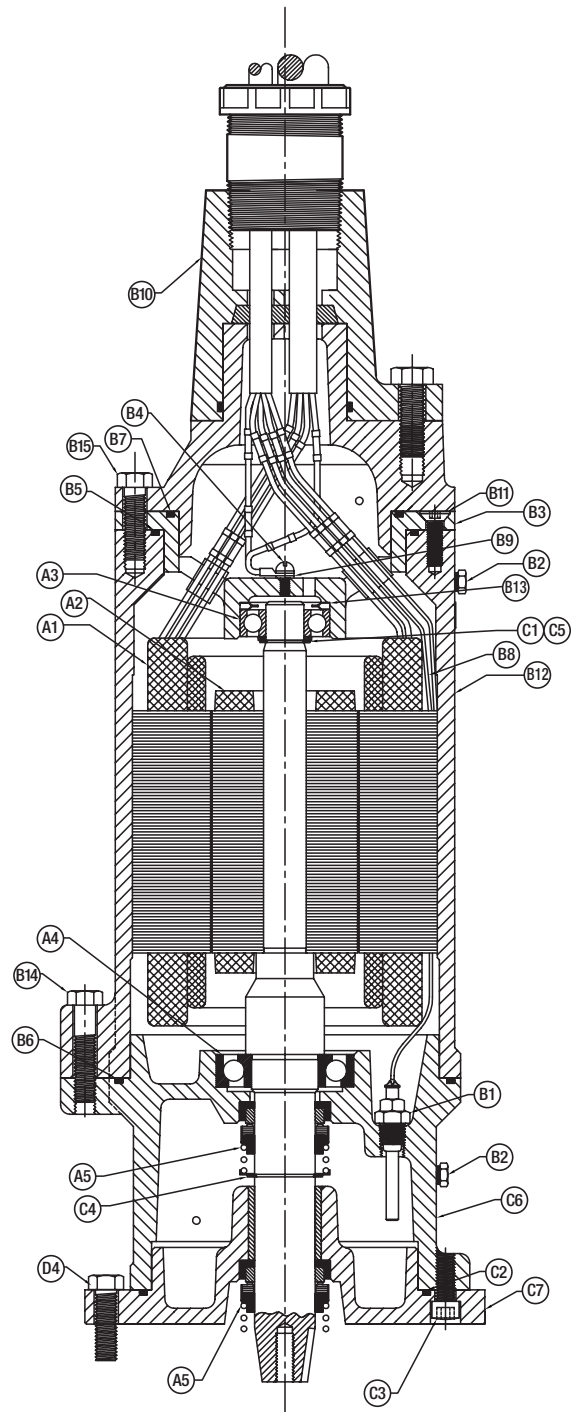

WIRING DIAGRAM

1 PHASE

BLACK, WHITE, AND RED MOTOR LEADS CAN ONLY BE CONNECTED TO PANEL TERMINAL BLOCKS AS SHOWN ON SCHEMATIC. INCORRECT CONNECTION CAN CAUSE DAMAGE TO PUMP AND/OR PANEL COMPONENTS. THREE PHASE OVERLOAD RELAY MUST BE CLASS 10 TRIP & AMBIENT COMPENSATED & CONNECTED IN THE 'DAISY CHAIN' CIRCUIT AS SHOWN.

Notes:

- 1) Level Switches Must Be Rated a Minimum of 2 Amps at 120 Volts
- 2) Torque all white field wiring terminals to 20 In.Lbs.
- 3) Field Wiring Must Be 60°C Copper Wire Minimum.
- 4) ----- = Items Not Supplied In Control Panel.
- 5) Pump power, heat sensor, and seal probe cables must pass through approved NEC 501.15 conduit seals.

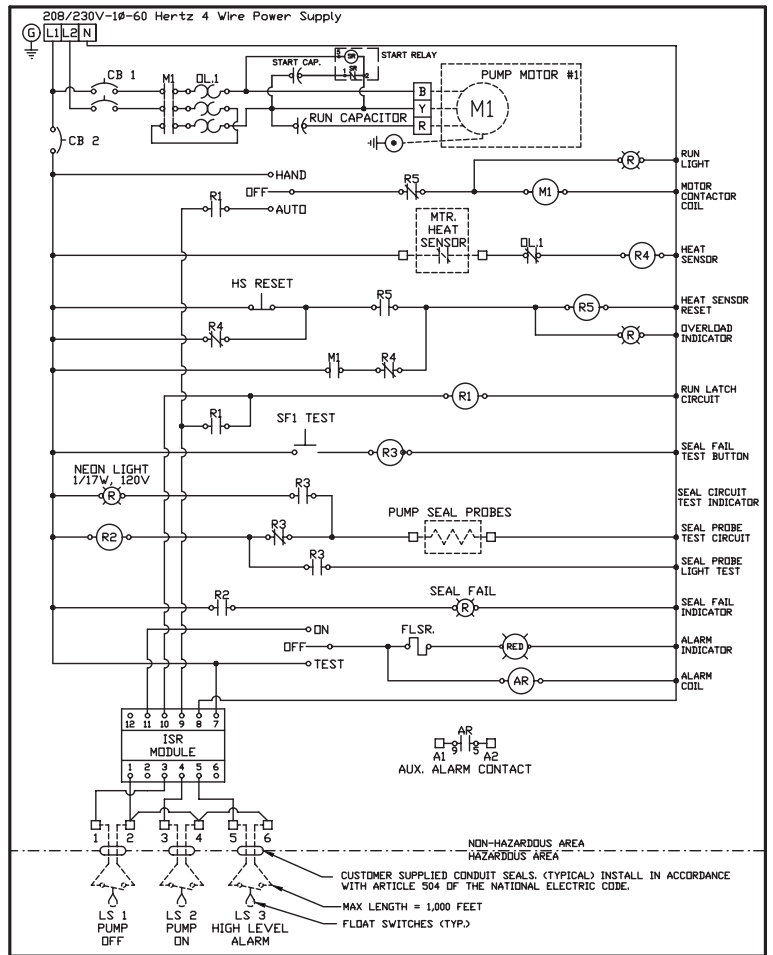

3 PHASE

Notes:

- 1) Level Switches Must Be Rated a Minimum of 2 Amps at 120 Volts
- 2) Torque all white field wiring terminals to 20 In.Lbs.
- 3) Field Wiring Must Be 60°C Copper Wire Minimum.
- 4) ----- = Items Not Supplied In Control Panel.
- 5) Pump power, heat sensor, and seal probe cables must pass through approved NEC 501.15 conduit seals.

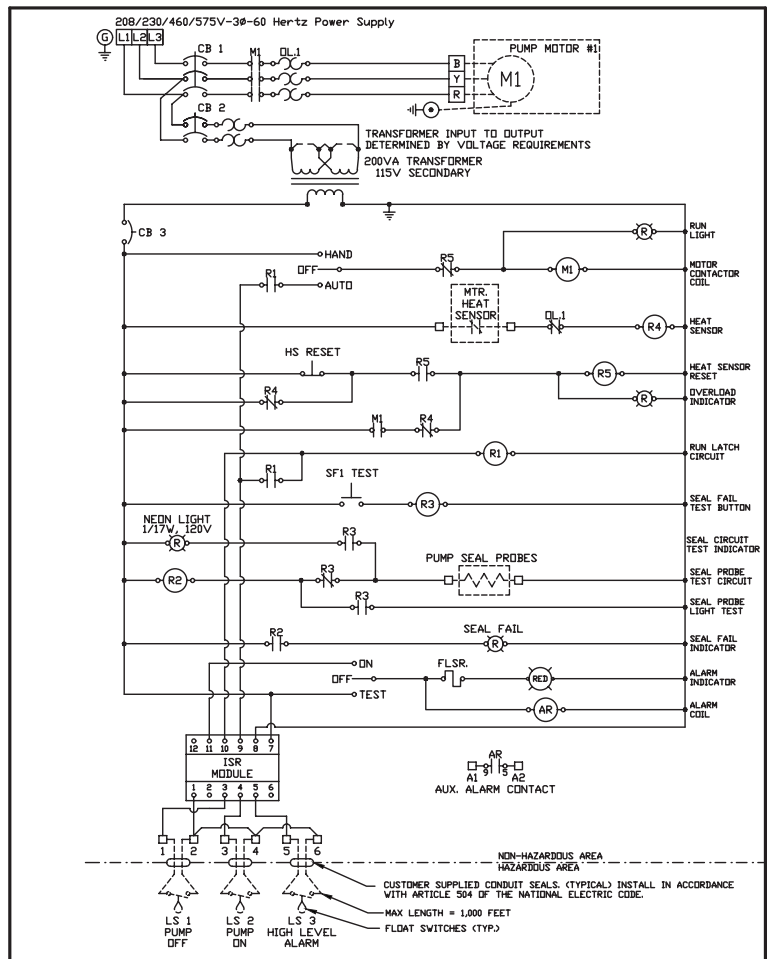

CHECK LIST IF PUMP DOES NOT OPERATE PROPERLY

Checking for Moisture in Motor: Use an ohmmeter or a megger and set on highest scale. Readings on the large power cord between any of the conductors red, black or white to the green conductor, or to the motor housing, should be greater than 1,000,000 ohms (1 megohm). Service work should only be done at an authorized service station. Note, readings should be taken with line leads disconnected from the control panel.

Resistance of Windings: Every motor winding has a fixed resistance. The windings must check close to specification values. Verification of the proper wiring of a dual voltage motor can also be checked by measuring the motor winding resistance.

CONDITION

Red light comes on at control box.

PROBABLE CAUSE

This indicates some water has leaked past the lower seal and has entered the seal chamber and made contact with the electrode probe. Pump must be removed for replacement of lower seal. This preventative repair will save an expensive motor.

Overload trips at control box and alarm buzzer or flashing red light comes on due to high water level in basin.

1. Push in on red reset button to reset overload. If overload trips again after short run, pump has some damage and must be removed from basin for checking.
2. Trouble may be from clogged impeller causing motor to overload or could be from failed motor.
3. Trouble may be from faulty component in control box. Always check control box before removing pump.

Yellow run light stays on continuously.

1. Indicates H-O-A switch may be in the Hand position.
2. Level control switch may have failed causing pump to continue to operate when water is below lower control.
3. Impeller may be partially clogged causing pump to operate at very reduced capacity.
4. Gate valve or check valve may be clogged causing low pump flow.
5. Pump may be air locked.

Circuit breaker trips.

1. Reset breaker by pushing completely down on handle then back to On position. If breaker trips again in few seconds it indicates excessive load probably caused by a short in the motor or control box. Check out instructions given with control box before pulling pump.
2. If this condition happens after an electrical storm, motor or control box may be damaged by lightning.
3. Resistance reading of the motor with lead wires disconnected from the control box can determine if trouble is in motor or control box.

Pump is noisy and pump rate is low.

1. Impeller may be partially clogged with some foreign objects causing noise and overload on the motor.
2. Impeller may be rubbing on wear ring due to bent shaft or misalignment.
3. Pump may be operating too close to shut-off. Check head.

Grease and solids have accumulated around pump and will not pump out of basin.

1. Lower control switch may be set too high.
2. Run pump on hand operation for several minutes with small amount of water running into basin to clean out solids and grease. This allows pump to break suction and surge which will break up the solids. If level switch is set properly this condition generally will not occur.
3. Trash and grease may have accumulated around floats causing pump to operate erratically.

V AND VR SERIES LIMITED WARRANTY

Pentair Myers® warrants its V and VR series grinders against defects in material and workmanship for a period of 24 months from the manufacturing date, or 36 months from the manufacturing date with completion of a start-up report within 30 days of installation. Product must be properly installed, serviced and operated in compliance with the manufacturer's instruction manuals.

During the warranty period and subject to the conditions set forth, Pentair Myers, at its discretion, will repair or replace to the original user, the parts that prove defective in materials and workmanship. Pentair Myers reserves the right to change or improve its products or any portions thereof without being obligated to provide such a change or improvement for prior sold and/or shipped units.

Start-up reports and electrical schematics may be required to support warranty claims. Submit at the time of start-up through the Pentair Myers website: <http://forms.pentairliterature.com/startupform/startupform.asp?type=m>. All seal fail and heat sensing devices must be connected, functional and monitored or this warranty will be void. Pentair Myers will cover only the lower seal and labor thereof for all dual seal pumps. Under no circumstance will Pentair Myers be responsible for the cost of field labor, travel expenses, rented equipment, removal/reinstallation costs or freight expenses to and from the factory or an authorized Pentair Myers service facility.

This limited warranty will not apply:

- a) To defects or malfunctions resulting from failure to properly install, operate or maintain the unit in accordance with the printed instructions provided;
- b) To failures resulting from abuse, accident or negligence;
- c) To failures resulting from excessive sand, lime, cement, gravel or other abrasive materials
- d) To failures caused by scale or corrosion build-up due to excessive hydrocarbons or chemical content
- e) To normal maintenance services and parts used in connection with such service;
- f) To units that are not installed in accordance with applicable local codes, ordinances and good trade practices;
- g) If the unit is moved from its original installation location;
- h) If unit is used for purposes other than for what it is designed and manufactured;
- i) To any unit that has been repaired or altered by anyone other than Pentair Myers or an authorized Pentair Myers service provider;
- j) To any unit that has been repaired using non factory specified/OEM parts.

Warranty Exclusions: PENTAIR MYERS MAKES NO EXPRESS OR IMPLIED WARRANTIES THAT EXTEND BEYOND THE DESCRIPTION ON THE FACE HEREOF. PENTAIR MYERS SPECIFICALLY DISCLAIMS THE IMPLIED WARRANTIES OF MERCHANTABILITY AND FITNESS FOR ANY PARTICULAR PURPOSE.

Liability Limitation: IN NO EVENT SHALL PENTAIR MYERS BE LIABLE OR RESPONSIBLE FOR CONSEQUENTIAL, INCIDENTAL OR SPECIAL DAMAGES RESULTING FROM OR RELATED IN ANY MANNER TO ANY PENTAIR MYERS PRODUCT OR PARTS THEREOF. PERSONAL INJURY AND/OR PROPERTY DAMAGE MAY RESULT FROM IMPROPER INSTALLATION. PENTAIR MYERS DISCLAIMS ALL LIABILITY, INCLUDING LIABILITY UNDER THIS WARRANTY, FOR IMPROPER INSTALLATION. PENTAIR MYERS RECOMMENDS INSTALLATION BY PROFESSIONALS.

Some states do not permit some or all of the above warranty limitations or the exclusion or limitation of incidental or consequential damages and therefore such limitations may not apply to you. no warranties or representations at any time made by any representatives of Pentair Myers shall vary or expand the provision hereof.



MYERS®

1101 MYERS PARKWAY
ASHLAND, OHIO, USA 44805
419-289-1144

490 PINEBUSH ROAD, UNIT #4
CAMBRIDGE, ONTARIO, CANADA N1T 0A5
800-363-PUMP

WWW.FEMYERS.COM

Warranty Rev. 04/17

STANDARD LIMITED WARRANTY

Pentair Myers® warrants its products against defects in material and workmanship for a period of 12 months from the date of shipment from Pentair Myers or 18 months from the manufacturing date, whichever occurs first – provided that such products are used in compliance with the requirements of the Pentair Myers catalog and technical manuals for use in pumping raw sewage, municipal wastewater or similar, abrasive-free, noncorrosive liquids.

During the warranty period and subject to the conditions set forth, Pentair Myers, at its discretion, will repair or replace to the original user, the parts that prove defective in materials and workmanship. Pentair Myers reserves the right to change or improve its products or any portions thereof without being obligated to provide such a change or improvement for prior sold and/or shipped units.

Start-up reports and electrical schematics may be required to support warranty claims. Submit at the time of start-up through the Pentair Myers website: <http://forms.pentairliterature.com/startupform/startupform.asp?type=m>. Warranty is effective only if Pentair Myers authorized control panels are used. All seal fail and heat sensing devices must be hooked up, functional and monitored or this warranty will be void. Pentair Myers will cover only the lower seal and labor thereof for all dual seal pumps. Under no circumstance will Pentair Myers be responsible for the cost of field labor, travel expenses, rented equipment, removal/reinstallation costs or freight expenses to and from the factory or an authorized Pentair Myers service facility.

This limited warranty will not apply: (a) to defects or malfunctions resulting from failure to properly install, operate or maintain the unit in accordance with the printed instructions provided; (b) to failures resulting from abuse, accident or negligence; (c) to normal maintenance services and parts used in connection with such service; (d) to units that are not installed in accordance with applicable local codes, ordinances and good trade practices; (e) if the unit is moved from its original installation location; (f) if unit is used for purposes other than for what it is designed and manufactured; (g) to any unit that has been repaired or altered by anyone other than Pentair Myers or an authorized Pentair Myers service provider; (h) to any unit that has been repaired using non factory specified/OEM parts.

Warranty Exclusions: PENTAIR MYERS MAKES NO EXPRESS OR IMPLIED WARRANTIES THAT EXTEND BEYOND THE DESCRIPTION ON THE FACE HEREOF. PENTAIR MYERS SPECIFICALLY DISCLAIMS THE IMPLIED WARRANTIES OF MERCHANTABILITY AND FITNESS FOR ANY PARTICULAR PURPOSE.

Liability Limitation: IN NO EVENT SHALL PENTAIR MYERS BE LIABLE OR RESPONSIBLE FOR CONSEQUENTIAL, INCIDENTAL OR SPECIAL DAMAGES RESULTING FROM OR RELATED IN ANY MANNER TO ANY PENTAIR MYERS PRODUCT OR PARTS THEREOF. PERSONAL INJURY AND/OR PROPERTY DAMAGE MAY RESULT FROM IMPROPER INSTALLATION. PENTAIR MYERS DISCLAIMS ALL LIABILITY, INCLUDING LIABILITY UNDER THIS WARRANTY, FOR IMPROPER INSTALLATION. PENTAIR MYERS RECOMMENDS INSTALLATION BY PROFESSIONALS.

Some states do not permit some or all of the above warranty limitations or the exclusion or limitation of incidental or consequential damages and therefore such limitations may not apply to you. No warranties or representations at any time made by any representatives of Pentair Myers shall vary or expand the provision hereof.



MYERS®

1101 MYERS PARKWAY
ASHLAND, OHIO 44805
PH: 855-274-8947
WWW.FEMYERS.COM

490 PINEBUSH ROAD, UNIT 4
CAMBRIDGE, ONTARIO, CANADA N1T 0A5
PH: 800-363-7867
WWW.FEMYERS.COM