

MYERS® MW50

The Myers MW50 series sewage pumps are constructed of the most durable combination of materials to withstand the harshest sewage environments. The non-clog impeller can pass up to 2" solids. Provides the flow and head required residential and light commercial applications. Models available for manual operation with external controls, or automatic operation with tethered, piggyback mechanical float switch.



APPLICATIONS

Sewage, high-capacity sump, effluent

SPECIFICATIONS

Capacities – 135 GPM (510 LPM)
Shut-off Head – 27' (8.23 m)
Operation – Manual or automatic
Solids Handling – 2" (50.8 mm)
Liquids Handling – Domestic sewage and drain water
Intermittent Liquid Temperature – Up to 140°F (60°C)
Motor/Electrical Data – 1/2 HP, 1625 RPM, PSC (1Ø), oil-filled, 115V, 9A, 1Ø, 60Hz; 230V, 4.5A, 1Ø, 60Hz
Acceptable pH Range – 5-9
Discharge, NPT – 2" (50.8 mm)
Housing – Cast iron
Power Cord – 20', 16/3, SJTW
Impeller – Thermoplastic
Volute Case – Class 30 cast iron
Shaft Seal – Type 6, carbon and ceramic
Minimum Sump Diameter – Simplex: 24" (61 cm); Duplex: 36" (91.4 cm)

FEATURES

Two-vane Impeller

Provides maximum efficiency and eliminates jamming between impeller and volute – engineered thermoplastic composition

Restore Performance

Original performance standards can be restored by easily replacing a worn volute seal ring

High-capacity Handling

Passes full 2" solids

Cool Running

Durable, oil-filled motor for continuous bearing lubrication and maximum heat dissipation

Powerful Starts

High-torque, permanent split capacitor (PSC) motor; no starting switches or relays to wear out

Protects Against High Heat

Low amp draw from the efficient PSC motor means less heat build-up

Longer-lasting Motor

Lower ball bearing eliminates sleeve bearing wear and reduces motor wear

Improved Sealing

Long, flexible Type 6 seal provides high-pressure sealing with improved seal face protection by location

RESIDENTIAL AND LIGHT COMMERCIAL SEWAGE PUMP

MYERS® MW50

ORDERING INFORMATION

Catalog Number	HP	Volts	Phase/Cycles	Amps	Discharge Size	Switch Type	Cord Length	Approx. Wt. Lbs.
MW50-11	1/2	115	1/60	9.0	2"	Manual	20'	42
MW5011P	1/2	115	1/60	9.0	2"	Tethered Automatic*	20'	43
MW50-21	1/2	230	1/60	4.5	2"	Manual	20'	42
MW5021P	1/2	230	1/60	4.5	2"	Tethered Automatic*	20'	43

*Piggyback

DIMENSIONS

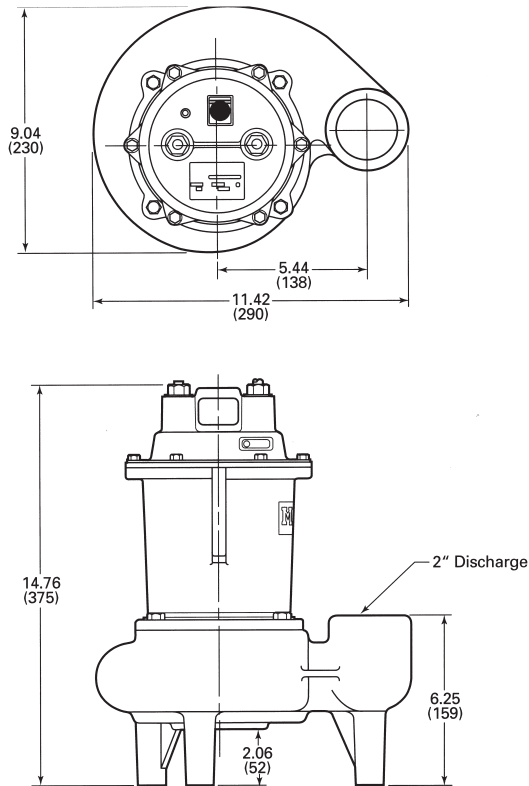

PUMP PERFORMANCE

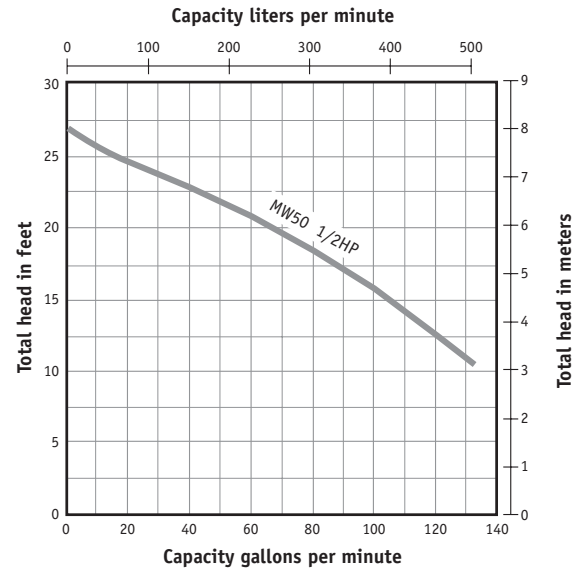

MYERS® MW50

SPECIFICATIONS

Sewage Pumps – Pump(s) shall be F. E. Myers MW50 series sewage pumps selected in accordance with the following design criteria:

Number of Pumps:	_____
Primary Design Flow:	_____
Primary Design Head:	_____
Minimum Shut-off Head:	27'
Motor Horsepower:	1/2
Motor Speed:	1625 RPM
Electrical:	115 Volts, 1Ø, 60 Hz or 230 Volts, 1Ø, 60 Hz

Pump – The pump shall be designed to handle raw sewage and be capable of passing 2 inch spherical solids. The pump shall be capable of handling liquids with temperatures to 140°F intermittent.

Motor – The pump motor shall be of the submersible type rated 1/2 hp at 1625 RPM and shall be for _____ 115 volts or _____ 230 volts single phase, 60 cycles. Single phase motor shall be of the permanent split capacitor type with no relays or starting switches. Stator winding shall be of the open type with Class A insulation rated for 105°C maximum operating temperature. The winding housing shall be filled with clean dielectric oil to lubricate bearings and seals, and transfer heat from the windings to the outer shell. The motor winding assembly shall be pressed into the stator housing for best alignment and heat transfer.

The motor shall be capable of operating over the full range of the performance curve without overloading the motor and causing any objectionable noise or vibration. The motor shall have two bearings to support the rotor; an upper sleeve bearing to accommodate radial loads and a lower sleeve bearing with thrust pad to take thrust and radial loads.

A heat sensor thermostat and overload shall be attached to the top end of the motor windings and shall be wired in series with the windings to stop the motor if the motor winding temperature reaches 221°F. The overload thermostat shall reset automatically when the motor cools to a safe operating temperature.

Power and Switch Cord – The motor power cord shall be 20 feet SJTW type. The power cord shall be of the positive sealing, quick-disconnect type. The power cable connection shall be sealed at the motor entrance by means of a compression nut which serves to make a positive electrical connection and prevent water from entering the cable jacket and motor housing.

Optional Control Switch – The sewage pump shall be controlled by an optional piggyback float switch. The float switch shall be of a non-mercury type and be capable of directly controlling the pump motor without the need for an external control panel.

Shaft Seal – The motor shall be protected by a rotating mechanical shaft seal. The seals shall have carbon and ceramic seal faces lapped to a tolerance of one light band. Metal parts and springs for seals shall be 300 series stainless steel.

Pump Impeller – The pump impeller shall be of the two vane enclosed type. The impeller shall be constructed of engineered thermoplastic or optional bronze. A stainless steel wear ring shall be pressed onto the neck of the impeller to provide a sealing surface. A replaceable Buna-N sealing cup shall effect a seal between the volute and impeller in order to maintain high efficiency and prevent recirculation.

Motor Castings – The motor housing castings shall be of high tensile strength Class 30 gray cast iron. Castings shall be treated with phosphate and chromate rinse and painted with a high quality air dry alkyd enamel for corrosion protection.

Pump Case – The pump case shall be a high efficiency volute design capable of passing 2 inch spherical solids. The pump volute shall be constructed of high tensile strength Class 30 gray cast iron.

Fasteners – All exposed fasteners shall be of 300 series stainless steel.

RESIDENTIAL AND LIGHT COMMERCIAL SEWAGE PUMP

MYERS® MW50



USA
293 WRIGHT STREET, DELAVAN, WI 53115 WWW.FEMYERS.COM
PH: 888-987-8677 ORDERS FAX: 800-426-9446

CANADA
490 PINEBUSH ROAD, UNIT 4, CAMBRIDGE, ONTARIO N1T 0A5
PH: 800-363-7867 ORDERS FAX: 888-606-5484

Because we are continuously improving our products and services, Pentair reserves the right to change specifications without prior notice.

© 2014 Pentair Ltd. All Rights Reserved.

M9031SSE (05/01/14)