

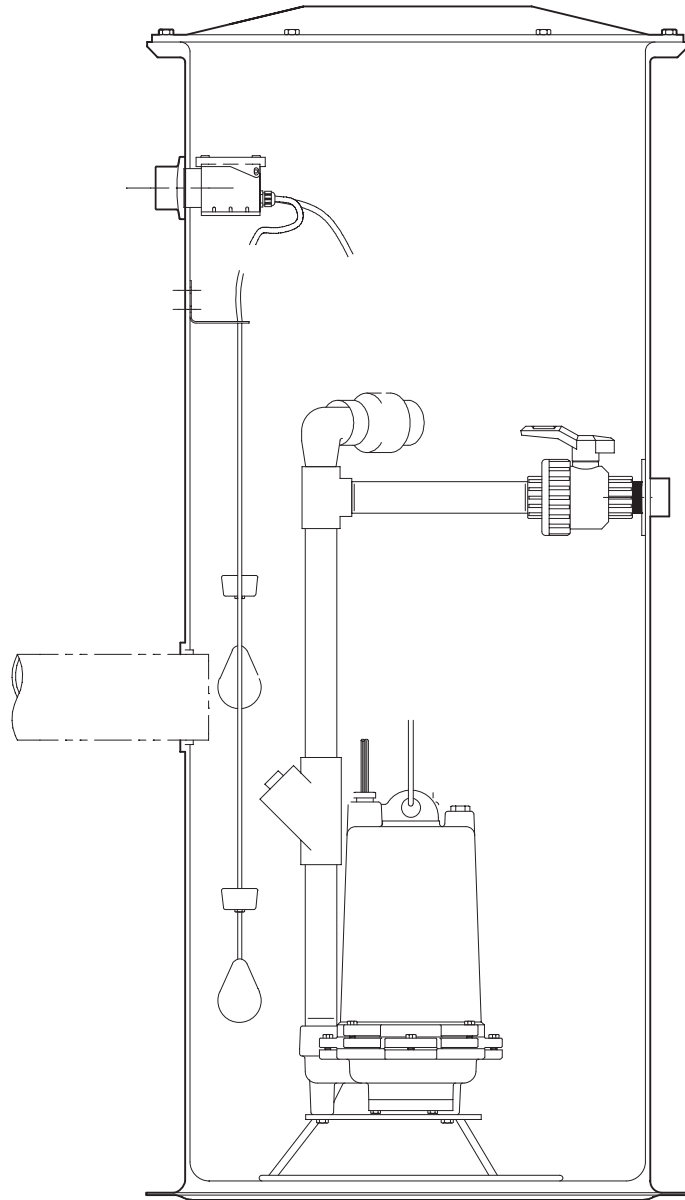

**MYERS®**



# MODEL SHA COMPLETE GRINDER PACKAGE SYSTEM

## INSTALLATION AND SERVICE MANUAL

NOTE! To the installer: Please make sure you provide this manual to the owner of the equipment or to the responsible party who maintains the system.

## GENERAL INFORMATION

Thank you for purchasing your Low Pressure Sewer Basin System.

### CALIFORNIA PROPOSITION 65 WARNING:

**▲ WARNING** This product and related accessories contain chemicals known to the State of California to cause cancer, birth defects or other reproductive harm.

## BEFORE INSTALLATION

This manual contains important information for the safe use of this product. Read this manual completely and follow the instructions carefully. Reasonable care and safe methods relating to the installation and operation of this product should be practiced. Check local codes and requirements before installation.

**▲ DANGER!** RISK OF ELECTRICAL SHOCK OR ELECTROCUTION. MAY RESULT IN SERIOUS INJURY OR DEATH OR FIRE HAZARD. INSTALLER MUST DISCONNECT ALL ELECTRICAL SOURCES PRIOR TO INSTALLATION. ONLY QUALIFIED PERSONNEL MAY INSTALL THIS SYSTEM. NFPA 70/NATIONAL ELECTRIC CODE (NEC) OR LOCAL CODES MUST BE FOLLOWED. SYSTEM MUST BE PROPERLY GROUNDED ACCORDING TO NEC.

**▲ WARNING!** BIOHAZARD RISK. ONCE THE WASTEWATER SOURCE HAS BEEN CONNECTED TO SYSTEM, BIOHAZARD RISK EXISTS. INSTALLER(S) AND/OR SERVICE PERSONNEL MUST USE PROPER PERSONAL PROTECTIVE EQUIPMENT AND FOLLOW HANDLING PROCEDURES PER OSHA 29 CFR 1910.1030 WHEN HANDLING EQUIPMENT AFTER WASTEWATER SOURCE HAS BEEN CONNECTED TO THE SYSTEM.

**▲ DANGER!** RISK OF FIRE OR EXPLOSION. DO NOT SMOKE OR USE OPEN FLAMES IN OR AROUND THIS SYSTEM. THIS SYSTEM IS NOT INTENDED FOR USE IN HAZARDOUS LOCATIONS PER NFPA 70 NATIONAL ELECTRIC CODE. CONSULT FACTORY FOR OPTIONAL EQUIPMENT RATED FOR THIS USE.

**▲ DANGER!** CUTTING RISK. RISK OF SERIOUS CUTTING OR AMPUTATION EXISTS. DISCONNECT ALL POWER SOURCES PRIOR TO HANDLING OR SERVICING PUMP OR GRINDING MECHANISM. PUMP MAY START WITHOUT WARNING. GRINDING MECHANISM IS EXTREMELY SHARP. USE CAUTION WHEN HANDLING GRINDER MECHANISM.

**▲ DANGER!** EXCAVATION LOCATION SHALL BE MADE ACCORDING TO LOCAL CODES AND REGULATIONS. CHECK WITH LOCAL UTILITY COMPANIES FOR THE LOCATION OF UNDERGROUND UTILITIES PRIOR TO EXCAVATION. CARE SHOULD BE TAKEN TO AVOID BURIED UTILITY LINES, PIPING, AND OTHER BURIED

STRUCTURES AND FOUNDATIONS. FAILURE TO FOLLOW THESE INSTRUCTIONS MAY RESULT IN SERIOUS PERSONAL INJURY OR DEATH.

## INSTALLATION SKILL REQUIREMENTS

The installation of a basin system is a specialized skill, which requires individuals with the basic understanding of excavating, pipe fitting, and electrical wiring. These instructions are meant only to be an installation guide; therefore, unusual installation conditions not covered in these instructions require experienced personnel capable of using reasonable engineering principles for the installation and operation of the system.

## BASIN INSTALLATION INSTRUCTIONS

### BASIN SYSTEM HANDLING

Factory built basin systems must not be dropped, dragged, rolled, or handled with sharp objects. Improper handling of basins may result in damage to the basin, damage to basin components, or leaks in the piping assemblies.

### STEP 1

The pad under the basin requires 4 to 6 inches of appropriate fill. The ideal basin pad is concrete in conjunction with antifoatation tie-down studs. Basin antifoatation tie-down kits are available from Myers. If concrete pad is not used, the aggregate must be compacted to a minimum 85% standard proctor density per ASTM D698, or as required by the authority having jurisdiction. Concrete pad or aggregate surface must be leveled flat and free of voids to conform to the basin bottom. Basin bedding depth should be calculated such that the basin top will protrude 3" above the normal grade upon final installation.

### STEP 2

Lifting of the basin may be done with a nylon or other nondamaging type material sling. Do not wrap a chain or steel cable around the basin as damage may result. Do not attach lifting mechanism around the discharge hub or electrical hub.

**▲ DANGER!** FAILURE TO PROPERLY SUPPORT ELECTRICAL CONDUIT, LINES AND CONNECTIONS MAY RESULT IN STRUCTURAL FAILURE. ELECTRICAL CONNECTIONS MAY BE DAMAGED EXPOSING LIVE ELECTRICAL CONNECTIONS.

**▲ CAUTION!** IF THE BASIN IS NOT TIED DOWN DURING INSTALLATION, RAIN OR FLOOD CONDITIONS MAY CAUSE THE BASIN TO FLOAT UPWARD, CAUSING DAMAGE TO THE BASIN OR BASIN CONNECTIONS. CLAIMS FOR THIS TYPE OF DAMAGE CANNOT BE PROCESSED BY MYERS.

### STEP 3

Lower the basin into excavation, position and level properly. Mount basin to base anchor bolts if an antil flotation tie-down kit is used. If basin is fiberglass, inspect basin and seal off any cuts or scratches to prevent fiberglass deterioration.

## INFLUENT AND DISCHARGE CONNECTIONS FOR FIBERGLASS BASINS

### STEP 1

An inlet grommet is the standard supplied influent connection device. Determine point at which influent line will enter basin and using a properly maintained piloted hole saw sized per chart below, drill a hole through the basin wall. If using a fiberglass basin, clean cut hole and apply a sealant coating to the cut section to prevent fiberglass deterioration. Insert the inlet grommet into the drilled hole.

Pipe Size	Hole Saw Diameter
3"	4"
4"	5"
6"*	7"

\*6" pipe size requires use of a fiberglass basin.

**▲ DANGER!** FAILURE TO USE A PROPERLY PILOTED HOLE SAW MAY RESULT IN DAMAGE TO BASIN WHICH MAY RESULT IN STRUCTURAL FAILURE OR SERIOUS LEAKS.

### STEP 2

Lubricate inside lip of inlet grommet with pipe soap. Clean outer end of influent pipe and push pipe through grommet. Ensure pipe does not protrude inside basin so as to interfere with pump removal or float operation.

### STEP 3

Close shutoff valve and make discharge line connection. It is strongly recommended that an additional shutoff valve and redundant check valve be located outside the basin at any force main entrances – **check local codes for specific requirements.**

## BACKFILL INSTRUCTIONS

The authority having jurisdiction has the right to require alternative materials or procedures for backfilling the installation.

**▲ WARNING!** FAILURE TO PROPERLY BACKFILL MAY RESULT IN DAMAGE TO THE BASIN WHICH COULD CAUSE LEAKS OR STRUCTURAL FAILURE. FAILURE TO FOLLOW THESE BACKFILL INSTRUCTIONS DURING THE INSTALLATION OF THE BASIN VOIDS THE BASIN WARRANTY.

**▲ CAUTION!** IN FREEZING CONDITIONS THE BACKFILL MUST BE DRY AND FREE OF ICE. DO NOT USE OTHER BACKFILL MATERIALS. FAILURE TO USE THE RECOMMENDED BED AND BACKFILL MATERIALS DURING THE INSTALLATION OF THE BASIN VOIDS THE BASIN WARRANTY.

### STEP 1

Obtain proper backfill material. The backfill material provides as much as 90% of the basin's support under certain stress conditions. The installer must be positive that correct bed and backfill materials are used per instructions as follows:

- Gravel – clean and free flowing with particle size not less than 1/8" nor more than 3/4" in diameter. Use this description when ordering or specifying as material varies upon geographical location. This material is commonly known as "pea gravel".
- Stone or gravel crushings with angular particle size of not less than 1/8" nor more than 1/2" diameter, washed and freeflowing, is acceptable as an alternative material.

### STEP 2

At least a 4 inch wide band of compacted aggregate must be placed in successive layers (6" lifts) around the entire periphery of the basin. Carefully compact aggregate under all piping and electrical lines. Cover grade should slope down 3" to the normal surrounding grade. Care must be taken to prevent damage to any influent, discharge, or electrical connections made to the basin.

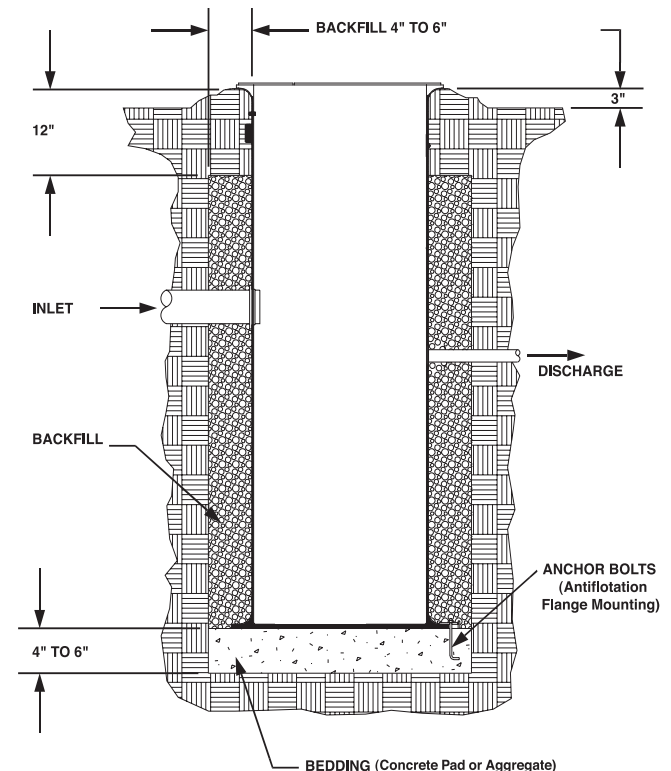

## FINAL BACKFILL FOR BASIN SYSTEMS

## INTERNAL BASIN INSTALLATION INSTRUCTIONS

Remove pump from carton. When unpacking unit, check for concealed damage. Claims for damage must be made at the receiving end through the delivery carrier. Damage cannot be processed from the factory.

### SYSTEMS DESCRIPTION

Factory built basin systems are available in 24" diameter basins with 48" through 96" depths in one foot increments. In the system, the pump and piping assembly are raised and lowered in the basin using rope attached to pump with integral union to facilitate piping disconnect.

### PUMP MODELS

The basin system may employ any 1 through 2 HP submersible grinder pump that uses cutter blades to grind solids into a slurry. These pump systems are designed for pumping effluent or sewage water only.

### GRINDER PUMP ATTACHMENTS

#### STEP 1

Attach the stainless steel foot bracket to bottom of the pump with bolts and washers provided.

#### STEP 2

Apply pipe by applying thread sealant to pipe threads and screw the discharge piping assembly into the pump discharge.

#### STEP 3

Attach lifting chain, cable or rope as supplied to the lifting eye bolts.

### INTERNAL BASIN CONNECTIONS

#### STEP 1

If the system is supplied with a float bracket, attach float switches to the float bracket by clamping strain relief bushings around the float cords, then inserting and twisting the bushings into the float bracket slots.

#### STEP 2

After grinder pump attachments have been made, lower the pump and piping assembly down, ensuring the discharge valve union aligns properly. Tighten the discharge valve union properly with discharge.

## SYSTEMS WITH JUNCTION BOX

### STEP 1

Ensure power source is off or disconnected and push pump power, seal failure/heat sensor, and float cords through cord grips in the junction box and tighten. To prevent corrosion or electrical short, plug any unused holes.

### STEP 2

Remove junction box cover and make all connections inside junction box to all incoming control panel wires. It is recommended that the customer furnish and install a conduit seal outside the basin to prevent surface water from entering the junction box.

## SYSTEMS WITHOUT JUNCTION BOX

### STEP 1

An inlet grommet for 2" PVC conduit is the standard supplied electrical conduit connection device. Determine the point at which the electrical conduit will enter the basin and, using a 3" diameter, properly maintained, piloted hole saw, drill a hole through the basin wall. If using a fiberglass basin, clean the edges of the hole and apply a sealant coating to the cut section to prevent fiberglass deterioration. Insert the inlet grommet into the drilled hole.

### STEP 2

Lubricate the inside lip of the inlet grommet with pipe soap. Clean the outer end of the conduit and push the conduit through the grommet. Ensure that the conduit does not protrude inside the basin so as to interfere with pump removal or float operation.

### STEP 3

Guide the pump and float switch cords through the conduit to the control panel. The pump cord length, control panel location and conduit length must allow the cords to run continuously to the control panel without splices.

### STEP 4

Make the electrical connections at the control panel. Seal the opening of the conduit at the entrance into the control panel with electrical putty or a similar sealant to prevent sewer gases from entering the control panel.

**▲ CAUTION! FAILURE TO PROPERLY SEAL THE ELECTRICAL CONDUIT FROM THE BASIN AT THE ENTRANCE TO THE CONTROL PANEL MAY ALLOW SEWER GASES TO CONDENSE INSIDE THE CONTROL PANEL AND CAUSE PREMATURE PANEL FAILURE. THIS WILL VOID ANY WARRANTY.**

## **PANEL WIRING**

**NOTE:** Failure to use a Myers approved control panel voids the pump/system warranty.

**IMPORTANT:** Properly connect the panel ground wire to a grounding rod. Improper grounding voids warranty.

### **STEP 1**

Ensure power source is off or disconnected.

### **STEP 2**

Connect pump power and float cords to panel terminals per the schematic. All conduits and cables entering the panel must be sealed off. Check panel wiring to ensure white, black, and red pump leads are connected according to the schematic and panel wire labels. Single phase pumps will run only if connected one way.

## **PREOPERATIONAL GRINDER PUMP CHECKS**

### **STEP 1**

Ensure power source is off or disconnected and remove pump from basin. With power off, turn radial cutter with a screwdriver to be sure it rotates freely.

## **PUMP OPERATIONS**

### **STEP 1**

Run clear water into the basin until motor housing is covered.

### **STEP 2**

Open the shut-off valve to the discharge line.

### **STEP 3**

Turn on the main breaker.

### **STEP 4**

Start the pump by pushing the "Push-to-run" push button inside the control panel.

### **STEP 5**

Check the pump amperage with clamp on ammeter on black pump lead. Readings higher than nameplate indicate clogged pump, miswiring, or improper voltage. If basin is not being pumped down and amperage readings are considerably lower than nameplate, then the pump may be air locked.

### **STEP 6**

Adjust floats so that the water level is above the pump motor housing, and the pump shuts off when the water level is 2 inches above the pump volute discharge.

## TROUBLE CHECKLIST

Troubles listed generally pertain to the pump and auxiliary components. Other trouble can occur from a faulty control box. These will be listed with the control box instructions.

CONDITION	PROBABLE CAUSE
<p><b>Pump runs but does not pump down the basin with the H-O-A switch on either Hand or Automatic position.</b></p>	<ol style="list-style-type: none"> <li>1. Cutters may be clogged. Amperage higher than nameplate may indicate this problem.</li> <li>2. Discharge gate valve may be closed.</li> <li>3. Clogging anywhere from cutters to check valve. This is evident if no water discharged out of the check valve after raising the pump to disconnect the sealing flange. Pull pump assembly and check for cause of clogging.</li> <li>4. Discharge head may be too high. Check elevation against design point of pump.</li> <li>5. Clogging beyond the sealing flange. This is evident if water is discharged through the check valve when raising the pump to disconnect the sealing flange. Inspect system basin piping or discharge piping from basin to locate clogging.</li> </ol>
<p><b>Basin level is pumped down when the "Push-to-run" push button is pushed, but is not pumped down in Automatic position.</b></p>	<ol style="list-style-type: none"> <li>1. Floats are not hanging free in the basin or are covered with grease. Pump the level down with the "Push-to-run" push button, so that the floats can be observed. Relocate and clean float(s) as necessary.</li> <li>2. If this is a new installation and original start-up, the floats may be miswired into the control panel. If the On and Off floats are reversed, the pump will short cycle on and off and will not pump the level down.</li> <li>3. Floats are malfunctioning. Pull the floats out of the basin and hang the Off and On floats from your hand. Tilt the Off float so that the large end is above the cord end – nothing should happen. While keeping the Off float tilted, tilt the On float in the same manner – the pump should come on. Suspend the On float again from your hand – the pump should continue to run. Finally, suspend the Off float – the pump should stop running. If this procedure does not cause the pump to operate as described, either replace the float(s) or replace the alternator relay if the system is duplex. <b>NOTE:</b> Use twisted shielded cable for seal failure cable runs in excess of 100 feet.</li> </ol>
<p><b>Pump run light stays on.</b></p>	<ol style="list-style-type: none"> <li>1. Lower float may have failed causing the pump to continue operating below the Off level.</li> <li>2. Pump may be air locked.</li> <li>3. Cutters may be clogged.</li> </ol>
<p><b>Circuit breaker trips when pump tries to start.</b></p>	<ol style="list-style-type: none"> <li>1. Short circuit in pump motor.</li> <li>2. Water may have entered the motor housing through either worn out mechanical seals or O-rings.</li> <li>3. Start component(s) failure. Check start capacitor and start relay for failure.</li> <li>4. Pump may be miswired to panel. The white, black, and red pump power leads must be connected correctly to panel.</li> </ol>

## FIBERGLASS SIMPLEX PARTS LIST

Ref. No.	Description	No. Req.	Part Number
1	Pump, MGPLD200-21, Sewage Grinder, 230V/60 Hz/1 $\phi$ , Positive Displacement	1	27315D011
	Pump, MG200-21, Sewage Grinder, 230V/60 Hz/1 $\phi$ , Centrifugal	1	26465D000
2	Stand for MGPLD200 Positive Displacement Pump	1	14887-003-1
	Stand for MG200 Centrifugal Pump	1	27078B005
3	Junction Box, NEMA-6, 2" NPT	1	12870-015-1
4	Float Control, Pump, 20' Cord	1	14595-320-1
5	Float Control, Alarm, 20' Cord	1	21813A322
6	Float Control Bracket	1	22470B005
7	Basin, 24" x 48", Fiberglass	1	23901D303
	Basin, 24" x 60", Fiberglass	1	23901D301
	Basin, 24" x 72", Fiberglass	1	23901D304
	Basin, 24" x 84", Fiberglass	1	23901D306
	Basin, 24" x 96", Fiberglass	1	23901D308
8	Basin Cover, Structural Foam	1	21936D200
9	Adapter, for 4" SCH40 PVC Pipe	1	24335A001
10	Adapter, for 2" SCH40 PVC Pipe or Conduit	2	24335A000
11	Flexible Discharge Pipe	1	13653-004-1
12	Discharge Valve, Single Union	1	11841-010-1
Not Shown	Control Panel, Positive Displacement Pump	1	27682A001
	Control Panel, Centrifugal Pump	1	27682A000

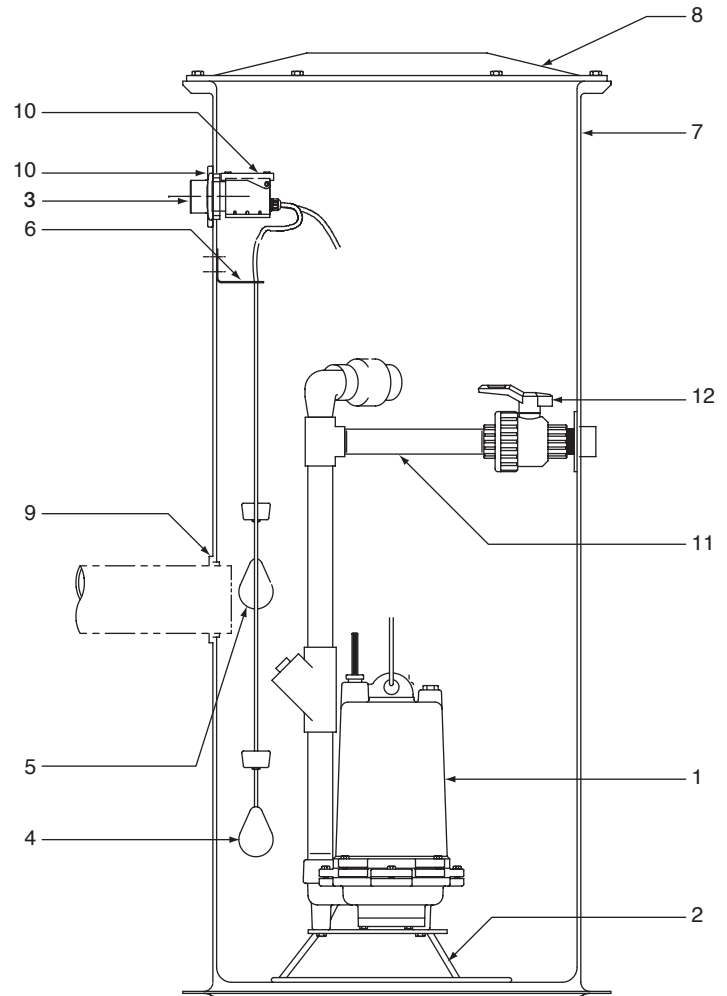

## STANDARD LIMITED WARRANTY

Pentair Myers® warrants its products against defects in material and workmanship for a period of 12 months from the date of shipment from Pentair Myers or 18 months from the manufacturing date, whichever occurs first – provided that such products are used in compliance with the requirements of the Pentair Myers catalog and technical manuals for use in pumping raw sewage, municipal wastewater or similar, abrasive-free, noncorrosive liquids.

During the warranty period and subject to the conditions set forth, Pentair Myers, at its discretion, will repair or replace to the original user, the parts that prove defective in materials and workmanship. Pentair Myers reserves the right to change or improve its products or any portions thereof without being obligated to provide such a change or improvement for prior sold and/or shipped units.

Start-up reports and electrical schematics may be required to support warranty claims. Submit at the time of start-up through the Pentair Myers website: <http://forms.pentairliterature.com/startupform/startupform.asp?type=m>. Warranty is effective only if Pentair Myers authorized control panels are used. All seal fail and heat sensing devices must be hooked up, functional and monitored or this warranty will be void. Pentair Myers will cover only the lower seal and labor thereof for all dual seal pumps. Under no circumstance will Pentair Myers be responsible for the cost of field labor, travel expenses, rented equipment, removal/reinstallation costs or freight expenses to and from the factory or an authorized Pentair Myers service facility.

This limited warranty will not apply: (a) to defects or malfunctions resulting from failure to properly install, operate or maintain the unit in accordance with the printed instructions provided; (b) to failures resulting from abuse, accident or negligence; (c) to normal maintenance services and parts used in connection with such service; (d) to units that are not installed in accordance with applicable local codes, ordinances and good trade practices; (e) if the unit is moved from its original installation location; (f) if unit is used for purposes other than for what it is designed and manufactured; (g) to any unit that has been repaired or altered by anyone other than Pentair Myers or an authorized Pentair Myers service provider; (h) to any unit that has been repaired using non factory specified/OEM parts.

Warranty Exclusions: PENTAIR MYERS MAKES NO EXPRESS OR IMPLIED WARRANTIES THAT EXTEND BEYOND THE DESCRIPTION ON THE FACE HEREOF. PENTAIR MYERS SPECIFICALLY DISCLAIMS THE IMPLIED WARRANTIES OF MERCHANTABILITY AND FITNESS FOR ANY PARTICULAR PURPOSE.

Liability Limitation: IN NO EVENT SHALL PENTAIR MYERS BE LIABLE OR RESPONSIBLE FOR CONSEQUENTIAL, INCIDENTAL OR SPECIAL DAMAGES RESULTING FROM OR RELATED IN ANY MANNER TO ANY PENTAIR MYERS PRODUCT OR PARTS THEREOF. PERSONAL INJURY AND/OR PROPERTY DAMAGE MAY RESULT FROM IMPROPER INSTALLATION. PENTAIR MYERS DISCLAIMS ALL LIABILITY, INCLUDING LIABILITY UNDER THIS WARRANTY, FOR IMPROPER INSTALLATION. PENTAIR MYERS RECOMMENDS INSTALLATION BY PROFESSIONALS.

Some states do not permit some or all of the above warranty limitations or the exclusion or limitation of incidental or consequential damages and therefore such limitations may not apply to you. No warranties or representations at any time made by any representatives of Pentair Myers shall vary or expand the provision hereof.



### MYERS®

1101 MYERS PARKWAY  
ASHLAND, OHIO, USA 44805  
419-289-1144

490 PINEBUSH ROAD, UNIT #4  
CAMBRIDGE, ONTARIO, CANADA N1T 0A5  
800-363-PUMP

[WWW.FEMYERS.COM](http://WWW.FEMYERS.COM)

Warranty Rev. 12/13