



EVERPURE® QC7I TRIPLE - MC² SYSTEM

DELIVERS PREMIUM QUALITY WATER FOR FOUNTAIN APPLICATIONS

QC7I Triple - MC² System: EV9275-03
MC² Replacement Cartridge: EV9612-56



APPLICATIONS

Fountain Beverage
For Most Dual-Carbonator Dispensers
Dispensers Using Up To 50 Tanks Of Syrup
or Bag-In-Box Per Month

FEATURES • BENEFITS

Improves the taste of fountain beverages and helps retain the drink's carbonation
Sanitary cartridge replacement is simple, quick and clean. Internal filter parts are never exposed to handling or contamination
Proprietary Micro-Pure(R) II filtration media effectively inhibits the growth of bacteria on the filter media that can decrease the life of the product
Protects drink system seals, pump, tubing and small orifices from clogging, corrosion and abrasive wear

Exclusive precoat filtration provides superior chlorine taste & odor reduction and micro-filters dirt and particles as small as 0.2* micron in size by mechanical means
Manifold features water shut-off, flushing valve and outlet pressure gauge

NSF/ANSI Standard 53 certified to reduce cysts such as *Cryptosporidium* and *Giardia* by mechanical means

* Validated by ISO 17025 accredited lab for 99.999% reduction of *Pseudomonas diminuta* following the ASTM F838-05 protocol for the validation of 0.2 µm sterilizing grade filters.

INSTALLATION TIPS

Choose a mounting location suitable to support the full weight of the system when operating.
Never use saddle valve for connection.
Use 3/4" water line.
Install vertically with cartridge hanging down.
Allow 2 1/2" (6.35 cm) clearance below the cartridge for easy cartridge replacement.
Flush cartridge by running water through system for five (5) minutes at full flow.

OPERATION TIPS

Change cartridges on a regular six (6) month preventative maintenance program.
Change cartridges when capacity is reached or when pressure falls below 10 psi (0.7 bar).
Service flow rate must not exceed 5.0 gpm (18.9 Lpm).
Always flush the filter cartridge at time of installation and cartridge change.

SIZING

Service Flow Rate: Maximum 5.0 gpm (18.9 Lpm)
Rated Capacity: 27,000 gallons (102,206 L)

EVERPURE® QC7I TRIPLE - MC² SYSTEM

EV9275-03

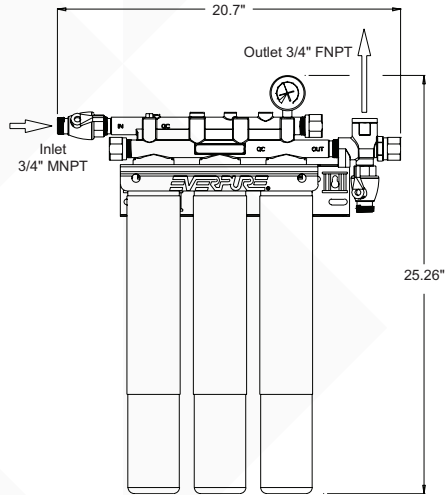

SPECIFICATIONS

Service Flow Rate

Maximum 5.0 gpm (18.9 Lpm)

Rated Capacity

27,000 gallons (102,206 L)

Pressure Requirements

10 – 125 psi (0.7 – 8.6 bar), non-shock

Temperature

35 – 100°F (2 – 38°C)

Overall Dimensions

25.26" H x 20.7" W x 5.5" D
(64.1 cm x 52.5 cm x 13.9 cm)

Inlet Connection

3/4"

Outlet Connection

3/4"

Electrical Connection

None required

Shipping Weight

15 lbs (6.8 kgs)

Operating Weight

24 lbs (10.8 kgs)



System Tested and Certified by NSF International against NSF/ANSI Standards 42 and 53 for the reduction of:

STANDARD NO. 42 — AESTHETIC EFFECTS

- Chemical Reduction
- Taste & Odor
- Chlorine

- Mechanical Filtration
- Nominal Particulate, Class I

STANDARD NO. 53— HEALTH EFFECTS

- Mechanical Filtration
- Cyst Reduction
- Turbidity Reduction
- Asbestos Reduction

EPA Est. No. 002623-IL-002

The contaminants or other substances removed or reduced by this drinking water system are not necessarily in your water. Do not use with water that is microbiologically unsafe or of unknown quality without adequate disinfection before or after the system. Systems certified for cyst reduction may be used with disinfected water that may contain filterable cysts.

Since the conditions under which our products may be used are beyond our control, we cannot accept any liability with respect to the improper installation, application and/or use of our products.

WARRANTY

Everpure water treatment systems by Pentair® (excluding replaceable elements) are covered by a limited warranty against defects in material and workmanship for a period of five years after date of purchase. Everpure replaceable elements (filter cartridges and water treatment cartridges) are covered by a limited warranty against defects in material and workmanship for a period of one year after date of purchase. See printed warranty for details. Pentair will provide a copy of the warranty upon request.



WATER QUALITY SYSTEMS

EVERPURE-SHURFLO WORLD HEADQUARTERS, 1040 MUIRFIELD DRIVE, HANOVER PARK, IL 60133 USA • FOODSERVICE.PENTAIR.COM
800.942.1153 (US ONLY) • 630.307.3000 MAIN • 630.307.3030 FAX • CSEVERPURE@PENTAIR.COM EMAIL

EVERPURE-SHURFLO AUSTRALIA, 1-21 MONASH DRIVE, DANDENONG SOUTH, VIC 3175, AUSTRALIA
011.1300 576 190 TEL • 011.61.39.562.7237 FAX • AU.EVERPURE@PENTAIR.COM EMAIL

EVERPURE-SHURFLO CHINA, 21F CLOUD 9 PLAZA, NO 1118, SHANGHAI, 200052, CHINA
86.21.3211.4588 TEL • 86.21.3211.4580 FAX • CHINA.WATER@PENTAIR.COM EMAIL

EVERPURE-SHURFLO INDIA, GREEN BOULEVARD, B-9/A, 7TH FLOOR - TOWER B SECTOR 62, NOIDA - 201301
91.120.419.9444 TEL • 91.120.419.9400 FAX • INDIACUSTOMER@PENTAIR.COM EMAIL

EVERPURE-SHURFLO EUROPE, PENTAIR WATER BELGIUM BVBA, INDUSTRIEPARK WOLFSTEE, TOEKOMSTLAAN 30, B-2200 HERENTALS, BELGIUM
+32.(0).14.283.504 TEL • +32.(0).14.283.505 FAX • SALES@EVERPURE-EUROPE.COM EMAIL

EVERPURE-SHURFLO JAPAN INC., HASHIMOTO MN BLDG. 7F, 3-25-1 HASHIMOTO, MIDORI-KU, SAGAMIHARA-SHI KANAGAWA 252-0143, JAPAN
81.(0)42.775.3011 TEL • 81.(0)42.775.3015 FAX • INFO@EVERPURE.CO.JP EMAIL

EVERPURE-SHURFLO SOUTHEAST ASIA, SOUTHEAST ASIA, 390 HAVELOCK ROAD, #04-01 KING'S CENTRE, SINGAPORE 169662
65.6768.5800 TEL • 65.6737.5149 FAX • CSEVERPURE@PENTAIR.COM EMAIL

All Pentair trademarks and logos are owned by Pentair, Inc. All other brand or product names are trademarks or registered marks of their respective owners. Because we are continuously improving our products and services, Pentair reserves the right to change specifications without prior notice. Pentair is an equal opportunity employer.