



► FROM PENTAIR WATER SOLUTIONS

# FX-11 WATER FILTRATION SYSTEM

System Part Number: 160-50010



## SYSTEM DESCRIPTION

The FX-11 water filtration system features a drop-in 10-inch carbon cartridge that reduces sediment, chlorine, taste and odors. It maintains a steady flow rate of 1.5 gallons per minute and filters up to 15,000 gallons before requiring a cartridge change.

## FEATURES • BENEFITS

- ◆ Gradient density filtration reduces chlorine, taste & odor while providing particulate reduction down to 2 microns\*
- ◆ Sturdy mounting bracket and full-flow inlet shutoff valve simplify installation
- ◆ Built-in pressure gauge visually indicates when filters need changing
- ◆ Inlet shutoff and pressure-relief valves simplify filter replacement
- ◆ NSF/ANSI Standard 42 certified for Bacteriostatic Effects and the reduction of Chlorine, Taste & Odor, and Particulate Class III

## APPLICATIONS

- ◆ Tea
- ◆ Coffee
- ◆ Foodservice
- ◆ Drinking water
- ◆ Fountain beverage

## INSTALLATION TIPS

- ◆ Choose a mounting location suitable to support the weight of the system while operating.
- ◆ Install vertically and allow 3" (7.62 cm) clearance below the cartridge for easy removal and replacement.
- ◆ Feed water temperature must not exceed 100°F (38°C).
- ◆ Do not install where the system could be exposed to freezing temperatures.
- ◆ Feed water supply pressure must not exceed 125 psi (non-shock). When pressure exceeds 85 psi, a pressure reducing valve is recommended.
- ◆ Flush cartridges by running water through the system for five (5) minutes.
- ◆ For more details, see the installation, operation, and maintenance guide included with the system.

\*As tested by Pentair

# FX-11 WATER FILTRATION SYSTEM

160-50010

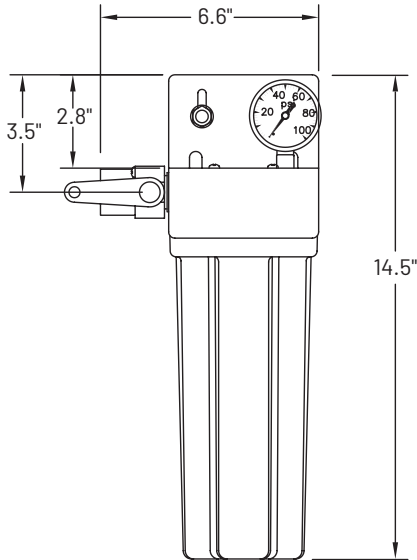

## SPECIFICATIONS

System	Performance
<b>Overall Dimensions</b> 14.5" L x 6.6" W x 5.1" D 36.3 cm x 16.8 cm x 13.0 cm	<b>Service Flow Rate</b> 1.5 gpm (5.69 lpm)
<b>Connections</b> Inlet: 1/2" PTC fittings Outlet: 1/2" PTC fittings	<b>Rated Capacity</b> 15,000 gal (56,781 L)
<b>Operating Pressure</b> 10 - 125 psi (0.7 - 8.6 bar)	<b>Chlorine Reduction</b> Yes
<b>Water Temperature</b> 35 - 100°F (2 - 38°C)	<b>Taste &amp; Odor Reduction</b> Yes
<b>Shipping Weight</b> 6 lbs (2.7 kgs)	<b>Particulate Reduction</b> Yes
<b>Electrical Connection</b> None required	

## REPLACEMENT CARTRIDGE

Model	Qty	Description	Part No
CTO-10	1	Primary filter	252-00210

For Pentair Everpure Product Warranties visit:  
<http://pentair.com/assets/foodservice-warranty>.  
 To receive a free copy email or call your Pentair representative using the information provided below.

It is recommended that filter cartridges be replaced every 12 months on a regular scheduled program, or when capacity is reached or if water pressure or flow to equipment becomes inadequate.

Do not use with water that is microbiologically unsafe or of unknown quality without adequate disinfection before or after the system.



System Tested and Certified by NSF International against NSF/ANSI Standard 42 for the reduction of:

- AESTHETIC EFFECTS
- Bacteriostatic Effects
- Chemical Reduction
- Taste & Odor
- Chlorine
- Mechanical Filtration
- Nominal Particulate Class III



1040 Muirfield Drive | Hanover Park, IL 60133 | 800.942.1153 (US Only) 630.307.3000 Main | [cseverpure@pentair.com](mailto:cseverpure@pentair.com) | [foodservice.pentair.com](http://foodservice.pentair.com)

All indicated Pentair trademarks and logos are property of Pentair. Third party registered and unregistered trademarks and logos are the property of their respective owners.

©2025 Pentair. All rights reserved.

160-50010 JL25