

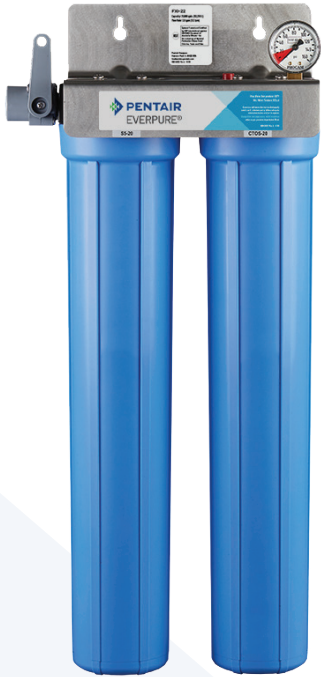

► FROM PENTAIR WATER SOLUTIONS

FXI-22 WATER FILTRATION SYSTEM

System Part Number: 160-50115



SYSTEM DESCRIPTION

The FXI-22 water filtration system features two drop-in 20-inch carbon cartridges that reduce sediment, chlorine, taste and odors. It features a scale-inhibiting technology designed to minimize scale buildup and prevent corrosion. The system maintains a steady flow rate of three (3) gallons per minute and filters up to 30,000 gallons before requiring a cartridge change.

FEATURES • BENEFITS

- ◆ Gradient-density sediment filtration reduces dirt, rust and sediment down to 2 microns*
- ◆ Additional 5 micron pre-filter provides added protection on water supplies with excessive sediment
- ◆ Sturdy mounting bracket and full-flow inlet shutoff valve simplify installation
- ◆ Built-in pressure gauge visually indicates when filters need changing
- ◆ Inlet shutoff and depressurization valves simplify filter replacement
- ◆ NSF/ANSI Standard 42 certified for Bacteriostatic Effects and the reduction of Chlorine, Taste & Odor, and Particulate Class III

APPLICATIONS

- ◆ Coffee
- ◆ Ice machines

INSTALLATION TIPS

- ◆ Choose a mounting location suitable to support the weight of the system while operating.
- ◆ Install vertically and allow 2½" (6.35 cm) clearance below the cartridge for easy removal and replacement.
- ◆ Feed water temperature must not exceed 100°F (38°C).
- ◆ Do not install where the system could be exposed to freezing temperatures.
- ◆ Feed water supply pressure must not exceed 125 psi (non-shock). When pressure exceeds 85 psi, a pressure reducing valve is recommended.
- ◆ Flush cartridges by running water through the system for five (5) minutes.
- ◆ For more details, see the installation, operation, and maintenance guide included with the system.

*As tested by Pentair

FXI-22 WATER FILTRATION SYSTEM

160-50115

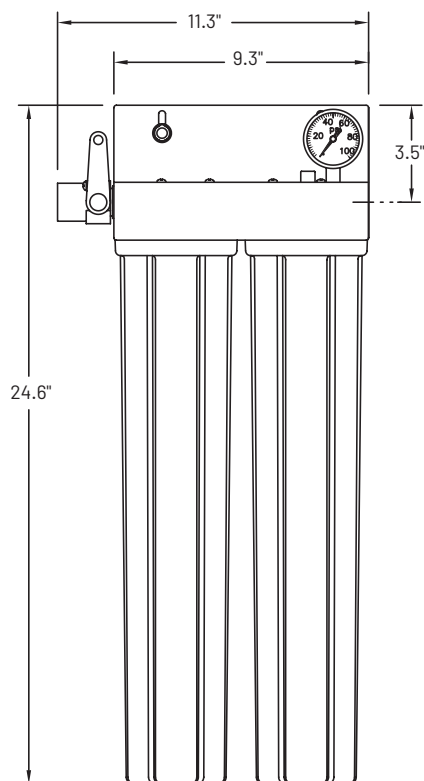

SPECIFICATIONS

System	Performance
Overall Dimensions 24.6" L x 11.3" W x 5.6" D 62.5 cm x 28.7 cm x 14.2 cm	Service Flow Rate Maximum 3.0 gpm (11.4 Lpm)
Connections Inlet: 1/2" PTC fittings Outlet: 1/2" PTC fittings	Rated Capacity 30,000 gallons (113,562 L)
Operating Pressure 10 - 125 psi (0.7 - 8.6 bar)	Chlorine Reduction Yes
Water Temperature 35 - 100°F (2 - 38°C)	Taste & Odor Reduction Yes
Shipping Weight 14 lbs (6.4 kgs)	Particulate Reduction Yes
Electrical Connection None required	

REPLACEMENT CARTRIDGE

Model	Qty	Description	Part No
CTOS-20	1	Primary filter	252-00320
S5-20	1	Sediment filter	252-10120

For Pentair Everpure Product Warranties visit:
<http://pentair.com/assets/foodservice-warranty>.
 To receive a free copy email or call your Pentair representative using the information provided below.

It is recommended that filter cartridges be replaced every 12 months on a regular scheduled program, or when capacity is reached or if water pressure or flow to equipment becomes inadequate.

Do not use with water that is microbiologically unsafe or of unknown quality without adequate disinfection before or after the system.



System Tested and Certified by NSF International against NSF/ANSI Standard 42 for the reduction of:

AESTHETIC EFFECTS
 Chemical Reduction
 Taste & Odor
 Chlorine
 Mechanical Filtration
 Nominal Particulate Class III



1040 Muirfield Drive | Hanover Park, IL 60133 | 800.942.1153 (US Only) 630.307.3000 Main | cseverpure@pentair.com | foodservice.pentair.com

All indicated Pentair trademarks and logos are property of Pentair. Third party registered and unregistered trademarks and logos are the property of their respective owners.

©2026 Pentair. All rights reserved.

160-50115 FE26