



► FROM PENTAIR WATER SOLUTIONS

FXAF-12B SYSTEM

System Part Number: 160-50340



SYSTEM DESCRIPTION

The **FXAF-12B** is a single-housing water filtration system. Gradient-density media filters sediment down to 5 microns and provides chlorine, taste & odor reduction. These features can help ensure optimum equipment performance and deliver better-tasting beverages and ice.

FEATURES • BENEFITS

- ◆ Gradient-density sediment filtration media provides chlorine, taste & odor reduction and filters dirt and sediment as small as 5 microns
- ◆ Integrated scale inhibitor helps minimize scale and corrosion buildup on equipment surfaces
- ◆ Built-in pressure gauge allows visual monitoring of when filters need to be changed
- ◆ Sturdy mounting bracket and full-flow inlet shut-off valve simplify installation
- ◆ Easy, quick change cartridge replacement

APPLICATIONS

- ◆ Ice
- ◆ Coffee
- ◆ Espresso
- ◆ Tea
- ◆ Fountain Beverage

INSTALLATION TIPS

- ◆ Always flush the cartridge at time of installation and cartridge change.
- ◆ Do not exceed cartridge specifications for temperature and pressure.
- ◆ Allow 3" clearance below system for filter housing removal and cartridge replacement.
- ◆ For more details, see the installation, operation, and maintenance guide included with your Everpure from Pentair Water Solutions system.

FXAF-12B SYSTEM

160-50340

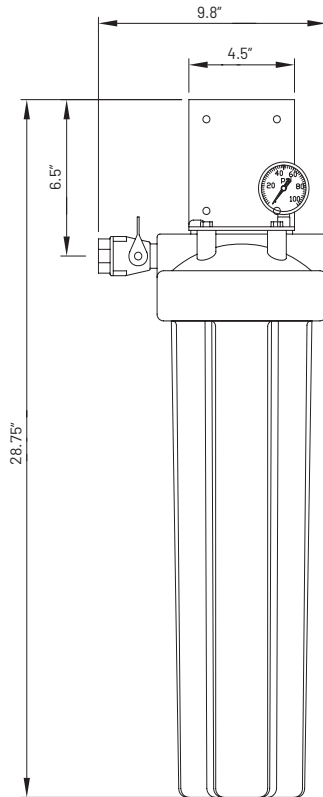

SPECIFICATIONS

Cartridge

Overall Dimensions
28.75" H x 9.8" W x 5.1" D
(73.0 cm x 24.9 cm x 12.9 cm)

Connections
Inlet Connection: 3/8" FNPT
Outlet Connection: 3/8" FNPT

Operating Pressure
10 - 125 psi (0.7 - 8.6 bar) non-shock

Water Temperature
35 - 100°F (2 - 38°C)

Shipping Weight
18 lbs (8.1 kgs)

Electrical Connection
None required

Performance

Service Flow Rate
8.0 gpm (30.3 lpm)

Rated Capacity
N/A

REPLACEMENT CARTRIDGE

Model	Qty	Description	Part No
S5-20B	2 pk	Drop-in filter cartridge	252-10410

For Pentair Everpure Product Warranties visit:
<http://pentair.com/assets/foodservice-warranty>.
To receive a free copy email or call your Pentair representative using the information provided below.

It is recommended that filter cartridges be replaced every six (6) months on a regular scheduled program, or when capacity is reached or if water pressure or flow to equipment becomes inadequate.

Always replace filter cartridges at least once per year.

Do not use with water that is microbiologically unsafe or of unknown quality without adequate disinfection before or after the system.



1040 Muirfield Drive | Hanover Park, IL 60133 | 800.942.1153 (US Only) 630.307.3000 Main | cseverpure@pentair.com | foodservice.pentair.com

All indicated Pentair trademarks and logos are property of Pentair. Third party registered and unregistered trademarks and logos are the property of their respective owners.

©2024 Pentair. All rights reserved.

160-50340 JL24