

OP175/16 SYSTEM

REVERSE OSMOSIS WATER TREATMENT SYSTEM WITH STORAGE TANK

System:

- OP175/16: 164-00216

Replacement Cartridges:

- CTO-Q10: 300-05828

- AMS-Q115: 204-52820

- MA-Q10: 300-05850



APPLICATIONS

- ◆ Combi Ovens
- ◆ Steam Ovens
- ◆ Proofers and Humidifiers

FEATURES • BENEFITS

- ◆ Significantly reduces scale and corrosion problems related to high TDS, water hardness and chlorides
- ◆ Ideal for all applications where TDS, hardness and chloride reduction are necessary to meet manufacturer's warranty requirements
- ◆ Integrated mineral-addition cartridge provides TDS needed for conductivity sensors and optimal mineral content for all equipment applications
- ◆ High capacity prefilters take out sediment and chlorine and protect the RO membrane
- ◆ Digital before-and-after TDS meter for push-button monitoring of membrane performance and optimized water quality
- ◆ Sample port allows quick and simple system checks and adjustments
- ◆ Integrated system bypass valve reduces service interruptions and down-time
- ◆ All consumables are easy to-change Qwik-Twist cartridges
- ◆ Built-in pressure gauge allows visual monitoring of operating pressure
- ◆ Simple, easy-to-install and service design

INSTALLATION TIPS

- ◆ Feed water connection to system should be COLD only. Tempered water up to 80°F (26.6°C) can be used.
- ◆ Do not exceed system specifications for temperature and pressure.
- ◆ Provide a dedicated water line of at least 1/2" I.D. to the unit for consistent flow and pressure to the system.
- ◆ Allow 3" clearance below system for filter cartridge removal and replacement.
- ◆ Connect filtered water line to steam production connections only. Do not use for condenser and wash-water.
- ◆ Detailed installation, operation and maintenance manual are included with each system.

SIZING

- ◆ Drain Connection: 2.0 gpm Minimum Flow
- ◆ Storage Tank Capacity: 16 gals.

OPERATION TIPS

- ◆ Change cartridges on a regular six (6) month preventative maintenance program.
- ◆ Change cartridges when capacity is reached or when flow becomes too slow.
- ◆ Always flush the filter cartridge at time of installation and cartridge change.

OP175/16 SYSTEM

164-00216

System:

- OP175/16: 164-00216

Replacement Cartridges:

- CTO-Q10: 300-05828
- AMS-QT15: 204-52820
- MA-Q10: 300-05850

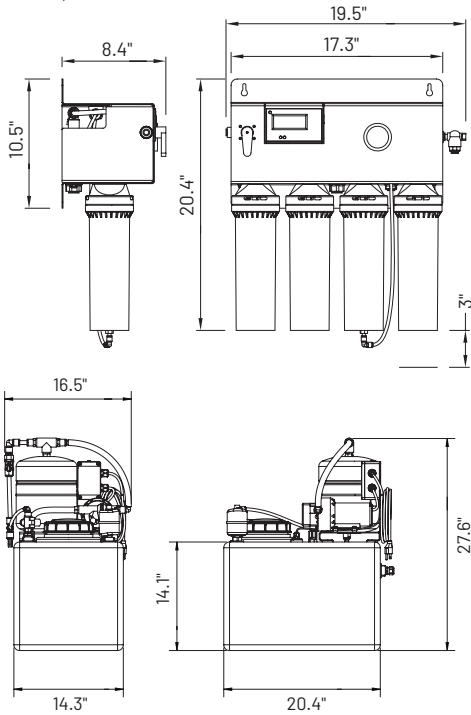

SPECIFICATIONS

- ◆ **Service Flow Rate**
Up to 4 gpm (15 Lpm) at 50 psi
- ◆ **Daily Production Rate**
175 gpd (633 Lpd) at 77°F (25°C), 60 psi (4.1 bar) feed water pressure. Production will vary based on water supply temperature and pressure
- ◆ **Storage Tank Capacity**
16 gallons (60.6 L)
- ◆ **Drain Connection**
Minimum 2.0 gpm (7.6 Lpm)
- ◆ **Pressure Requirements**
60 - 85 psi (3.5 - 5.9 bar), non-shock
- ◆ **Inlet Water Temperature**
40 - 100°F (4 - 38°C)
- ◆ **Overall Dimensions**
Processor:
20.4" H x 19.5" W x 8.4" D
51.8 cm x 49.5 cm x 21.3 cm
Tank:
27.3" H x 16.5" W x 20.4" D
69.3 cm x 42 cm x 51.8 cm

- ◆ **Inlet Connection**
3/8" Push Fit Tubing
- ◆ **Outlet Connection**
1/2" I.D. hose
- ◆ **Shipping Weight**
100 lbs (45.36 kgs)
- ◆ **Electrical Connection**
Repressurization Pump:
120 VAC / 60 Hz / 2 Amps

Feed Water Chemistry

Feed TDS	Up to 1200 ppm
Feed pH	6-10 units
Hardness*	12 grains or less
Free Chlorine	<2 mg/L
Iron	0.1 mg/L max
Turbidity	0.50 NTU
Manganese	0.05 mg/L max
Hydrogen Sulfide	0.00 mg/L

* For water outside of these parameters, call Pentair Customer Service.

The contaminants or other substances removed or reduced by this drinking water system are not necessarily in your water. Do not use with water that is microbiologically unsafe or of unknown quality without adequate disinfection before or after the system.

Since the conditions under which our products may be used are beyond our control, we cannot accept any liability with respect to the improper installation, application and/or use of our products.

For Pentair® Everpure® Product Warranties visit:
<http://pentair.com/assets/foodservice-warranty>

Options

Model	Description	Part No
Air-Gap Kit	Air-Gap Approved for drain line	164-89905
BPA200	Booster Pump Assy	164-85015
QTPTCR-10-1	QT Chloramine Reduction System	160-52085
PRV	Pressure Reducing Valve	164-89938

Replacement Media

Model	Qty	Description	Part No
CTO-Q10	2	Pre-Filter	300-05828
AMS-QT15	1	Membrane	204-52820
MA-Q10	1	Post-Filter	300-05850

It is recommended that pre/post-filters and mineral addition cartridges are changed every six (6) months, when capacity is reached or when feed water pressure or flow becomes inadequate.



United States | 1040 Muirfield Drive | Hanover Park, IL 60133 | 800.942.1153 (US Only) 630.307.3000 Main | cseverpure@pentair.com | foodservice.pentair.com
Australia | 1-21 Monash Drive | Dandenong South, Vic 3175 | Australia | 011.1300 576 190 Tel | au.everpure@pentair.com
China | 21F Cloud 9 Plaza, NO 1118 | Shanghai, 200052 | China | 86.21.3211.4588 Tel | china.water@pentair.com
India | Boulevard, B-9/A, 7th Floor - Tower B Sector 62 | Noida - 201301 | 91.120.419.9444 Tel | indiacustomer@pentair.com
Europe | Pentair Water Belgium BVBA | Industriepark Wolfstee, Toekomstlaan 30, B-2200 Herentals | Belgium | +32.(0).14.283.504 Tel | sales@everpure-europe.com
Japan | Japan Inc. | Hashimoto MN Bldg. 7F, | 3-25-1 Hashimoto, Midori-ku, Sagami-hara-shi | Kanagawa 252-0143 | Japan | 81.(0)42.775.3011 Tel | info@everpure.co.jp
Southeast Asia | 390 Havelock Road, | #04-01 King's Centre | Singapore 169662 | 65.6768.5800 Tel | cseverpure@pentair.com

All indicated Pentair trademarks and logos are property of Pentair. Third party registered and unregistered trademarks and logos are the property of their respective owners. Because we are continuously improving our products and services, Pentair reserves the right to change specifications without prior notice. Pentair is an equal opportunity employer.