

# OPS175CR/16 SYSTEM

## REVERSE OSMOSIS WATER TREATMENT SYSTEM WITH STORAGE TANK

**System:**

- OPS175CR/16: 164-01416

**Replacement Cartridges:**

- CTO-Q10: 300-05828

- AMS-QT15: 204-52820

- CTO-Q10CR: 300-05821

- ILMA-10.14: 252-70255



### APPLICATIONS

- ◆ Combi Ovens
- ◆ Steamers
- ◆ Proofers

### FEATURES • BENEFITS

- ◆ Significantly reduces scale and corrosion problems related to high TDS, water hardness and chlorides
- ◆ Ideal for combi and steam oven applications where mineral reduction is necessary to meet manufacturer's warranty requirements
- ◆ Integrated mineral-addition cartridge provides TDS needed for conductivity sensors and optimal mineral content for steam equipment applications
- ◆ High capacity pre-filter protects the membrane against damage from sediment and chlorine
- ◆ Operating pressure gauge allows visual monitoring of system production and pre-filter condition
- ◆ Plumbed-in post filter reduces chloramine
- ◆ Sealed hydropneumatic storage tank provides needed capacity and delivers pressurized water to downstream equipment.
- ◆ Optimized water line to equipment is 1/2" I.D. hose. A 3/4" Garden Hose Thread (GHT) connector is provided for connection to equipment when applicable.
- ◆ Integrated system bypass valve reduces costly service interruptions and down-time
- ◆ Compact, modular design utilizes installation under counters and in tight spaces
- ◆ Non-electric design operates on available water pressure
- ◆ Simple, easy-to-install and service design

### INSTALLATION TIPS

- ◆ Feed water connection to system should be COLD only. Tempered water up to 80° F (26.6°C) can be used.
- ◆ Do not exceed system specifications for temperature and pressure.
- ◆ Provide a dedicated feed water supply with a 1/2" FPT valve.
- ◆ For use with steam generation only. Do not use for condensate or wash-water.

- ◆ Allow 3" clearance below system for filter cartridge removal and replacement.
- ◆ Detailed, illustrated installation guide is included with each system.

### SIZING

- ◆ Drain Connection: 2.0 gpm Minimum Flow
- ◆ Storage Tank Capacity: 16 gals.

### OPERATION TIPS

- ◆ Change cartridges on a regular six (6) month preventative maintenance program.
- ◆ Change cartridges when capacity is reached or when flow becomes too slow.
- ◆ Membrane life varies depending on feed water conditions and pre-filter maintenance. It is recommended to replace the membrane every 18 months.
- ◆ Always flush the filter cartridge at time of installation and cartridge change.

# OPS175CR/16 SYSTEM

164-01416

- System:  
 - OPS175CR/16: 164-01416  
 Replacement Cartridges:  
 - CTO-Q10: 300-05828  
 - AMS-QT15: 204-52820  
 - CTO-Q10CR: 300-05821  
 - ILMA-10.14: 252-70255

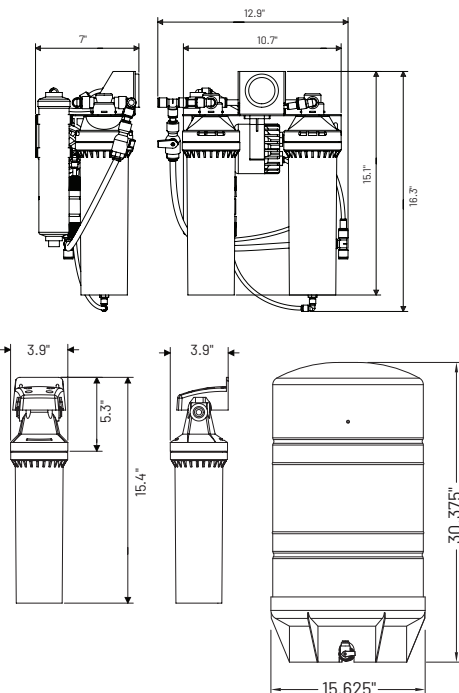

The contaminants or other substances removed or reduced by this drinking water system are not necessarily in your water. Do not use with water that is microbiologically unsafe or of unknown quality without adequate disinfection before or after the system.

Since the conditions under which our products may be used are beyond our control, we cannot accept any liability with respect to the improper installation, application and/or use of our products.

For Pentair® Everpure® Product Warranties visit:  
<http://pentair.com/assets/foodservice-warranty>



## SPECIFICATIONS

- ◆ **Service Flow Rate**  
 Dependent on water level / pressure in storage tank
- ◆ **Daily Production Rate**  
 175 gpd (633 Lpd) at 77°F (25°C), 60 psi (3.5 bar) feed water pressure. Production will vary based on water supply temperature, and pressure and desired blended TDS setting.
- ◆ **Drain Connection**  
 Minimum 2.0 gpm (7.6 Lpm)
- ◆ **Storage Tank Capacity**  
 16 gallons (61 L)
- ◆ **Pressure Requirements**  
 60 - 85 psi (3.5 - 5.9 bar), non-shock
- ◆ **Inlet Water Temperature**  
 40 - 100°F (4 - 38°C)
- ◆ **Overall Dimensions**  
**Processor:**  
 16.3" H x 12.9" W x 7" D  
 41.4 cm x 32.7 cm x 17.8 cm  
**Post Filter:**  
 15.4" H x 3.9" W x 3.9" D  
 39.1 cm x 9.9 cm x 9.9 cm  
**Tank:**  
 30.375" H x 15.625" dia.  
 77.15 cm x 39.62 cm

- ◆ **Inlet Connection**  
 3/8" Push Fit Tubing
- ◆ **Outlet Connection**  
 1/2" I.D. hose
- ◆ **Shipping Weight**  
 51 lbs (23.13 kgs)
- ◆ **Electrical Connection**  
 None required

## Feed Water Chemistry

Feed TDS	Up to 1200 ppm
Feed pH	6-10 units
Hardness*	12 grains or less
Free Chlorine	<2 mg/L
Iron	0.1 mg/L max
Turbidity	0.50 NTU
Manganese	0.05 mg/L max
Hydrogen Sulfide	0.00 mg/L

\*For water outside of these parameters, call Pentair Customer Service.

## Options

Model	Description	Part No
PRV	Pressure Reducing Valve	164-89938
BPS100	Booster Pump Assy	164-85010
Air-Gap Kit	Air-Gap Approved for Drain	164-89905

## Replacement Media

Model	Qty	Description	Part No
CTO-Q10	1	Pre-Filter	300-05828
AMS-QT15	1	Membrane	204-52820
ILMA-10.14	1	Mineral Addition	252-70255
CTO-Q10CR	1	Post-Filter	300-05821

It is recommended that pre/post-filters and mineral addition cartridges are changed every six (6) months, when capacity is reached or when feed water pressure or flow becomes inadequate.

**United States** | 1040 Muirfield Drive | Hanover Park, IL 60133 | 800.942.1153 (US Only) 630.307.3000 Main | [cseverpure@pentair.com](mailto:cseverpure@pentair.com) | [foodservice.pentair.com](http://foodservice.pentair.com)  
**Australia** | 1-21 Monash Drive | Dandenong South, Vic 3175 | Australia | 011.1300 576 190 Tel | [au.everpure@pentair.com](mailto:au.everpure@pentair.com)  
**China** | 21F Cloud 9 Plaza, NO 1118 | Shanghai, 200052 | China | 86.21.3211.4588 Tel | [china.water@pentair.com](mailto:china.water@pentair.com)  
**India** | Boulevard, B-9/A, 7th Floor - Tower B Sector 62 | Noida - 201301 | 91.120.419.9444 Tel | [indiacustomer@pentair.com](mailto:indiacustomer@pentair.com)  
**Europe** | Pentair Water Belgium BVBA | Industriepark Wolfstee, Toekomstlaan 30, B-2200 Herentals | Belgium | +32.(0).14.283.504 Tel | [sales@everpure-europe.com](mailto:sales@everpure-europe.com)  
**Japan** | Japan Inc. | Hashimoto MN Bldg. 7F, | 3-25-1 Hashimoto, Midori-ku, Sagami-hara-shi | Kanagawa 252-0143 | Japan | 81.(0)42.775.3011 Tel | [info@everpure.co.jp](mailto:info@everpure.co.jp)  
**Southeast Asia** | 390 Havelock Road, | #04-01 King's Centre | Singapore 169662 | 65.6768.5800 Tel | [cseverpure@pentair.com](mailto:cseverpure@pentair.com)

All indicated Pentair trademarks and logos are property of Pentair. Third party registered and unregistered trademarks and logos are the property of their respective owners. Because we are continuously improving our products and services, Pentair reserves the right to change specifications without prior notice. Pentair is an equal opportunity employer.