

BWS1500/300 HF PLUS SYSTEM

REVERSE OSMOSIS WATER TREATMENT SYSTEM WITH STORAGE TANK

System:

- BWS1500/300: HF Plus 164-15581

Replacement Cartridges:

- CTO-Q: 300-05830

- MA-Q15: 300-05855

Replacement Membrane:

- AMS-4021XLE: 204-44021



APPLICATIONS

- ◆ Any foodservice equipment where it is desirable to remove existing Total Dissolved Solids (TDS) and provide a consistent balance of buffered TDS. Designed for multiple point-of-use applications where up to 10 gpm is required.

FEATURES • BENEFITS

- ◆ Significantly reduces scale and corrosion problems related to high TDS, water hardness and chlorides
- ◆ Microprocessor controller provides system status and pump time-delay on start-up for pump protection
- ◆ Rotary vane pressure pump assures consistent production
- ◆ Adjustable reject flow control minimizes water use due to seasonal fluctuations in water temperature
- ◆ Precision blending valve allows the user to accurately and precisely blend filtered water with mineral-addition water to a desired optimized TDS Level
- ◆ High capacity Pre-filters take out sediment and chlorine and protect the RO membrane
- ◆ Digital before-and-after TDS meter for push-button monitoring of membrane performance and optimized water quality
- ◆ Sample port enables quick and simple system checks and adjustments
- ◆ Built-in pressure gauge allows visual monitoring of operating pressure
- ◆ Integrated system bypass valve reduces down-time or service interruptions
- ◆ All consumables are easy-to-change Qwik-Twist cartridges
- ◆ 1" high-flow outlet for high demand applications

INSTALLATION TIPS

- ◆ Feed water connection to system should be COLD only. Tempered water up to 80°F (26.6°C) can be used.
- ◆ Do not exceed system specifications for temperature and pressure.
- ◆ Provide a dedicated water line of at least 1/2" I.D. to the unit for consistent flow and pressure to the system.
- ◆ Allow 3" clearance below system for filter cartridge removal and replacement.
- ◆ Connect filtered water line to steam production connections only. Do not use for condensate or wash-water.

- ◆ Detailed installation, operation and maintenance manual is included with each system.
- ◆ Mount the unit where it can be easily viewed and accessed.

SIZING

- ◆ Drain Connection: 5.0 gpm Minimum Flow
- ◆ Storage Tank Capacity: 300 gals.

OPERATION TIPS

- ◆ Change cartridges on a regular six (6) month preventative maintenance program.
- ◆ Change cartridges when capacity is reached or when flow becomes too slow.
- ◆ Membrane life varies depending on feed water conditions and pre-filter maintenance. It is recommended to replace the membrane every 18 months.
- ◆ Always flush the filter cartridge at time of installation and cartridge change.

BWS1500/300 HF PLUS SYSTEM

164-15581

System:

- BWS1500/300: HF Plus 164-15581

Replacement Cartridges:

- CTO-Q: 300-05830

- MA-Q15: 300-05855

Replacement Membrane:

- AMS-4021XLE: 204-44021

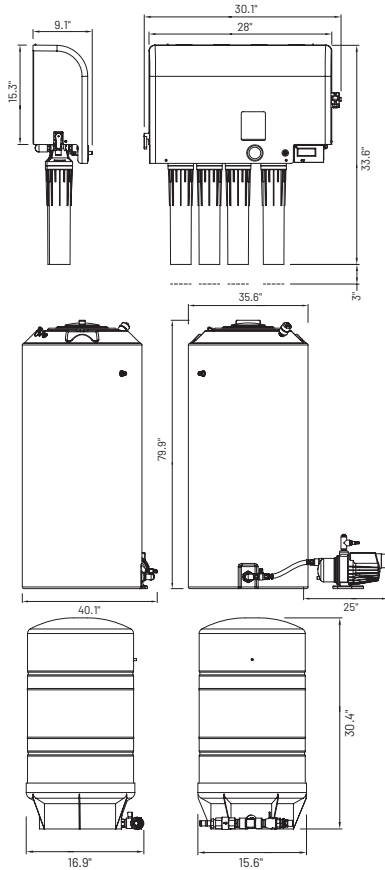

SPECIFICATIONS

- ◆ **Service Flow Rate**
Up to 10 gpm (>38 Lpm) at 60 psi
- ◆ **Daily Production Rate**
1,500 gpd (5,678 Lpd)(typical with blend) at 77°F (25°C), 60 psi (3.5 bar) feed water pressure. Production will vary based on water supply temperature and pressure, and desired blended TDS setting.
- ◆ **Storage Tank Capacity**
300 gallons (1135.62 L)
- ◆ **Drain Connection**
Minimum 5.0 gpm (18.9 Lpm)
- ◆ **Pressure Requirements**
30 - 90 psi (2.1 - 6.2 bar), non-shock
- ◆ **Inlet Water Temperature**
40 - 100°F (4 - 38°C)
- ◆ **Overall Dimensions**
Processor:
 33.6" H x 30.1" W x 9.1" D
 85.3 cm x 76.5 cm x 23.1 cm
Tank:
 79.9" H x 35.6" dia.
 203 cm x 90.4 cm
Buffer Tank:
 30.4" H x 15.6" dia.
 77.2 cm x 39.6 cm

- ◆ **Inlet Connection**
1/2" Push Fit Tubing
- ◆ **Outlet Connection**
1" I.D. hose
- ◆ **Shipping Weight**
340 lbs (154.22 kgs)
- ◆ **Electrical Connection**
Processor:
 120 VAC / 60 Hz / 6 Amps
Repressurization Pump:
 120 VAC / 60 Hz / 10 Amps

Feed Water Chemistry

Feed TDS	Up to 1200 ppm
Feed pH	6-10 units
Hardness*	12 grains or less
Free Chlorine	<2 mg/L
Iron	0.1 mg/L max
Turbidity	0.50 NTU
Manganese	0.05 mg/L max
Hydrogen Sulfide	0.00 mg/L

* For water outside of these parameters, call Pentair Customer Service.

The contaminants or other substances removed or reduced by this drinking water system are not necessarily in your water. Do not use with water that is microbiologically unsafe or of unknown quality without adequate disinfection before or after the system.

Since the conditions under which our products may be used are beyond our control, we cannot accept any liability with respect to the improper installation, application and/or use of our products.

For Pentair Everpure Product Warranties visit:
<http://pentair.com/assets/foodservice-warranty>

Options

Model	Description	Part No
Air-Gap Kit	Air-Gap Approved for drain line	164-89905

Replacement Media

Model	Qty	Description	Part No
CTO-Q	3	Pre-Filter	300-05830
AMS-QT4021XLE	1	Membrane	204-44021
MA-Q15	1	Post-Filter	300-05855

It is recommended that pre/post-filters and mineral addition cartridges are changed every six (6) months, when capacity is reached or when feed water pressure or flow becomes inadequate.



United States | 1040 Muirfield Drive | Hanover Park, IL 60133 | 800.942.1153 (US Only) 630.307.3000 Main | cseverpure@pentair.com | foodservice.pentair.com
Australia | 1-21 Monash Drive | Dandenong South, Vic 3175 | Australia | 011.1300 576 190 Tel | au.everpure@pentair.com
China | 21F Cloud 9 Plaza, NO 1118 | Shanghai, 200052 | China | 86.21.3211.4588 Tel | china.water@pentair.com
India | Boulevard, B-9/A, 7th Floor - Tower B Sector 62 | Noida - 201301 | 91.120.419.9444 Tel | indiacustomer@pentair.com
Europe | Pentair Water Belgium BVBA | Industriepark Wolfstee, Toekomstlaan 30, B-2200 Herentals | Belgium | +32.(0).14.283.504 Tel | sales@everpure-europe.com
Japan | Japan Inc. | Hashimoto MN Bldg. 7F, | 3-25-1 Hashimoto, Midori-ku, Sagami-hara-shi | Kanagawa 252-0143 | Japan | 81.(0)42.775.3011 Tel | info@everpure.co.jp
Southeast Asia | 390 Havelock Road, | #04-01 King's Centre | Singapore 169662 | 65.6768.5800 Tel | cseverpure@pentair.com

All indicated Pentair trademarks and logos are property of Pentair. Third party registered and unregistered trademarks and logos are the property of their respective owners. Because we are continuously improving our products and services, Pentair reserves the right to change specifications without prior notice. Pentair is an equal opportunity employer.