



► FROM PENTAIR WATER SOLUTIONS

# QTCR-2 SYSTEM

System Part Number: 170-52132



## SYSTEM DESCRIPTION

The QTCR-2 water filtration system utilizes activated carbon to reduce particulates, chloramine, chlorine, taste & odor at a flow rate of 3.4 gpm for 20,000-gallons. These features can help enhance water quality and extend the efficiency and lifespan of equipment.

## FEATURES • BENEFITS

- ◆ Gradient-density media filters dirt and particles as small as 5 microns.
- ◆ Activated-carbon filtration provides chloramines, chlorine, taste & odor reduction.
- ◆ Manifold design helps reduce potential leak points.
- ◆ Sturdy, powder-coated mounting bracket and multi-function valve simplify installation.
- ◆ Multi-function valve provides:
  - Shutoff valve for quick and simple filter replacements
  - System bypass valve for easy system maintenance
  - Flush port to flush cartridges after installation
- ◆ Built-in gauge visually indicates when filters may need to be changed
- ◆ Easy, Qwik-Twist replacement cartridges

## APPLICATIONS

- ◆ Fountain beverage

## INSTALLATION TIPS

- ◆ Choose a mounting location suitable to support the weight of the system while operating.
- ◆ Install vertically and allow 3" (7.62 cm) clearance below the cartridge for easy removal and replacement.
- ◆ Feed water temperature must not exceed 100°F (38°C).
- ◆ Do not install where the system could be exposed to freezing temperatures.
- ◆ Feed water supply pressure must not exceed 125 psi (non-shock). When pressure exceeds 85 psi, a pressure reducing valve is recommended.
- ◆ Flush cartridges by running water through the system for five (5) minutes.
- ◆ For more details, see the installation, operation, and maintenance guide included with your Everpure from Pentair Water Solutions system.

# QTCR-2 SYSTEM

170-52132

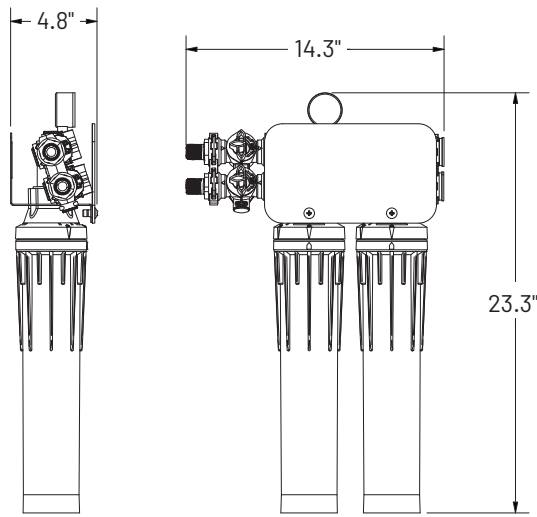

## SPECIFICATIONS

System	Performance
<b>Overall Dimensions</b> 23.3" L x 14.3" W x 4.8" D 59.2 cm x 36.3 cm x 12.2 cm	<b>Service Flow Rate - Maximum</b> 3.4 gpm (12.9 Lpm)
<b>Connections</b> Inlet Connection: 1/2" MNPT Outlet Connection: 1/2" MNPT	<b>Rated Capacity</b> 20,000 gallons (75,700 L)
<b>Operating Pressure</b> 10 - 125 psi (0.7 - 8.6 bar)	<b>Chlorine Reduction</b> Yes
<b>Water Temperature</b> 35 - 100°F (2 - 38°C)	<b>Taste &amp; Odor Reduction</b> Yes
<b>Operating Weight</b> 17 lbs (7.7 kgs)	<b>Chloramine Reduction</b> Yes
<b>Shipping Weight</b> 9 lbs (4.1 kgs)	<b>Particulate Reduction</b> Yes
<b>Electrical Connection</b> None required	

## REPLACEMENT CARTRIDGE(S)

Model	Qty	Description	Part No
CTO-QCR2	2	Primary filter	300-05833

For Pentair Everpure Product Warranties visit:  
<http://pentair.com/assets/foodservice-warranty>.  
To receive a free copy email or call your Pentair representative using the information provided below.

It is recommended that filter cartridges be replaced every six (6) months on a regular scheduled program, or when capacity is reached or if water pressure or flow to equipment becomes inadequate.

Always replace filter cartridges at least once per year.

Do not use with water that is microbiologically unsafe or of unknown quality without adequate disinfection before or after the system.

The contaminants or other substances reduced by this drinking water system are not necessarily in your water.



System Tested and Certified by NSF International against NSF/ANSI Standard 42 for the reduction of:

STANDARD NO. 42 –  
AESTHETIC EFFECTS  
Chemical Reduction  
Taste & Odor  
Chlorine  
Chloramine  
Mechanical Filtration  
Nominal Particulate Class III



1040 Muirfield Drive | Hanover Park, IL 60133 | 800.942.1153 (US Only) 630.307.3000 Main | [cseverpure@pentair.com](mailto:cseverpure@pentair.com) | [foodservice.pentair.com](http://foodservice.pentair.com)

All indicated Pentair trademarks and logos are property of Pentair. Third party registered and unregistered trademarks and logos are the property of their respective owners.

©2024 Pentair. All rights reserved.

170-52132 JL24