



# EVERPURE® CGS-10 10" SINGLE FILTER HOUSING

FOODSERVICE SYSTEM HOUSING FOR DROP-IN CARTRIDGES

CGS-10 10" Single Filter Housing: EV9100-10



## APPLICATIONS

Foodservice

## FEATURES • BENEFITS

10" low profile Slim Line single bowl housing assembly accepts drop-in cartridges

Includes wall mounting bracket and hardware for fast and easy installation

Manufactured of durable polypropylene

System includes water pressure gauge

Equipped with a pressure relief button to relieve water pressure during cartridge changes

Has excellent chemical resistance

System is shipped fully assembled

Choose the appropriate cartridge for your needs

Cartridge sold separately

## INSTALLATION TIPS

Choose a mounting location suitable to support the full weight of the system when operating.

Install vertically so bowl hangs down.

Allow 2 1/2" clearance below the cartridge for easy cartridge replacement.

Make sure o-ring on bowl is sufficiently lubricated .

Always screw on bowls by hand; do not use a housing wrench.

Flush filter by running water through filter according to cartridge instructions.

## OPERATION TIPS

Change cartridges on a regular six (6) month preventative maintenance program.

Change cartridges when capacity is reached or when pressure decreases.

Always inspect o-ring; change and/or lubricate if necessary.

Clean bowl with mild solution of detergent before inserting new cartridge.

Always flush the filter cartridge at time of installation and cartridge change.

## SIZING

Service Flow Rate: Maximum 2 gpm (7.6 Lpm)

# EVERPURE® CGS-10 10" SINGLE FILTER HOUSING

## EV9100-10

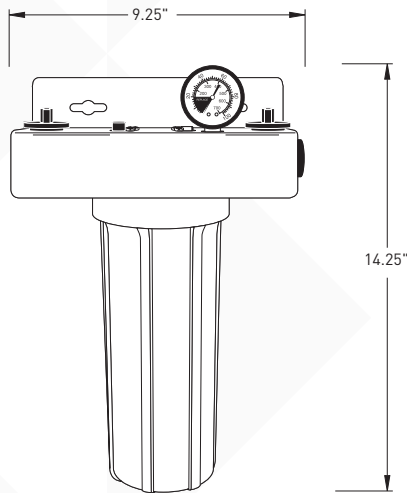

### SPECIFICATIONS

#### Service Flow Rate

Maximum 2 gpm (7.6 Lpm)

#### Pressure Requirements

30 - 125 psi (2.1 - 8.6 bar), non-shock

#### Overall Dimensions

14.25" H x 9.25" W x 5.25" D  
(36.1 cm x 23.4 cm x 13.3 cm)

#### Inlet Connection

3/8"

#### Outlet Connection

3/8"

#### Temperature Limits

40 - 100°F (4.4 - 38°C)

#### Electrical Connection

None required



Systems are Tested and Certified by NSF International against NSF/ANSI 42 & 53 for the reduction of the claims specified on the Performance Data Sheet and at [www.nsf.org](http://www.nsf.org).

The contaminants or other substances removed or reduced by this drinking water system are not necessarily in your water. Do not use with water that is microbiologically unsafe or of unknown quality without adequate disinfection before or after the system.

### WARRANTY

Everpure water treatment systems by Pentair® (excluding replaceable elements) are covered by a limited warranty against defects in material and workmanship for a period of five years after date of purchase. Everpure replaceable elements (filter cartridges and water treatment cartridges) are covered by a limited warranty against defects in material and workmanship for a period of one year after date of purchase. See printed warranty for details. Pentair will provide a copy of the warranty upon request.



#### WATER QUALITY SYSTEMS

EVERPURE-SHURFLO WORLD HEADQUARTERS, 1040 MUIRFIELD DRIVE, HANOVER PARK, IL 60133 USA • [FOODSERVICE.PENTAIR.COM](mailto:FOODSERVICE.PENTAIR.COM)  
800.942.1153 (US ONLY) • 630.307.3000 MAIN • 630.307.3030 FAX • [CSEVERPURE@PENTAIR.COM](mailto:CSEVERPURE@PENTAIR.COM) EMAIL

EVERPURE-SHURFLO AUSTRALIA, 1-21 MONASH DRIVE, DANDENONG SOUTH, VIC 3175 AUSTRALIA  
011.1300.576.190 TEL • 011.61.39.562.7237 FAX • [AU.EVERPURE@PENTAIR.COM](mailto:AU.EVERPURE@PENTAIR.COM) EMAIL

EVERPURE-SHURFLO CHINA, 21F CLOUD 9 PLAZA, NO 1118, SHANGHAI, 200052, CHINA  
86.21.3211.4588 TEL • 86.21.3211.4580 FAX • [CHINA.WATER@PENTAIR.COM](mailto:CHINA.WATER@PENTAIR.COM) EMAIL

EVERPURE-SHURFLO INDIA, GREEN BOULEVARD, B-9/A, 7TH FLOOR - TOWER B SECTOR 62, NOIDA - 201301  
91.120.419.9444 TEL • 91.120.419.9400 FAX • [INDIACUSTOMER@PENTAIR.COM](mailto:INDIACUSTOMER@PENTAIR.COM) EMAIL

EVERPURE-SHURFLO EUROPE, PENTAIR WATER BELGIUM BVBA, INDUSTRIEPARK WOLFSTEE, TOEKOMSTLAAN 30, B-2200 HERENTALS, BELGIUM  
+32.(0).14.283.504 TEL • +32.(0).14.283.505 FAX • [SALES@EVERPURE-EUROPE.COM](mailto:SALES@EVERPURE-EUROPE.COM) EMAIL

EVERPURE-SHURFLO JAPAN INC., HASHIMOTO MN BLDG. 7F, 3-25-1 HASHIMOTO, MIDORI-KU, SAGAMIHARA-SHI KANAGAWA 252-0143, JAPAN  
81.(0)42.775.3011 TEL • 81.(0)42.775.3015 FAX • [INFO@EVERPURE.CO.JP](mailto:INFO@EVERPURE.CO.JP) EMAIL

EVERPURE-SHURFLO SOUTHEAST ASIA, 390 HAVELOCK ROAD, #04-01 KING'S CENTRE, SINGAPORE 169662  
65.6768.5800 TEL • 65.6737.5149 FAX • [CSEVERPURE@PENTAIR.COM](mailto:CSEVERPURE@PENTAIR.COM) EMAIL

All Pentair trademarks and logos are owned by Pentair, Inc. or its affiliates. All other registered and unregistered trademarks and logos are the property of their respective owners. Because we are continuously improving our products and services, Pentair reserves the right to change specifications without prior notice. Pentair is an equal opportunity employer.