



# EVERPURE® TWIN SERIES HEAD

FILTER HEAD EXCLUSIVELY FOR EVERPURE REPLACEMENT CARTRIDGES

Twin Series Head: EV9272-24



## APPLICATIONS

Foodservice

## FEATURES • BENEFITS

New redesigned commercial quality filter head for Everpure filter cartridges

A cartridge nesting feature provides a more secure and durable fit

Includes mounting box bracket and screws for fast and easy installation. No extra mounting plate is required

Built-in water shut-off valve and flushing valve makes cartridge change outs easy

Series plumbed for use with a fine filter cartridge and any Everpure problem solving cartridge

Corrosion resistant hardware

New modular design of box bracket allows for future retrofitting of add-on components without disassembly of system. Optional wing bracket kits available

Engineered for durability, strength and longevity

All wetted parts have passed NSF® extraction tests

## INSTALLATION TIPS

Mounts directly onto flat surface.

Install vertically so cartridge hangs down.

Allow 2-1/2" (6.35 m) clearance below the cartridge for easy cartridge replacement.

Flush filter by running water through filter according to cartridge instructions.

## OPERATION TIPS

Change cartridges on a regular six (6) month preventative maintenance program.

Change cartridges when capacity is reached or when flow becomes too slow.

Always flush the filter cartridge at time of installation and cartridge change.

## SIZING

Rated Capacity: Varies according to filter cartridge used

# EVERPURE® TWIN SERIES HEAD

## EV9272-24

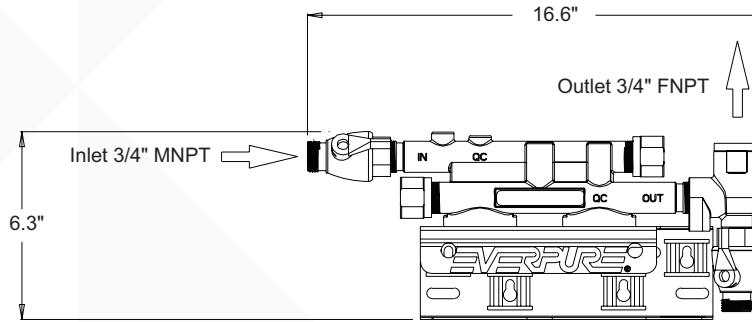

### SPECIFICATIONS

#### Overall Dimensions

6.3" H x 16.6" W x 5.5" D  
(16.0 cm x 42.1 cm x 13.9 cm)

#### Inlet Connection

3/4"

#### Outlet Connection

3/4"

#### Rated Capacity

Varies according to filter cartridge used

#### Electrical Connection

None required

#### Shipping Weight

3 lbs (1.3 kgs)

The contaminants or other substances removed or reduced by this drinking water system are not necessarily in your water. Do not use with water that is microbiologically unsafe or of unknown quality without adequate disinfection before or after the system.

### WARRANTY

Everpure water treatment systems by Pentair® (excluding replaceable elements) are covered by a limited warranty against defects in material and workmanship for a period of five years after date of purchase. Everpure replaceable elements (filter cartridges and water treatment cartridges) are covered by a limited warranty against defects in material and workmanship for a period of one year after date of purchase. See printed warranty for details. Pentair will provide a copy of the warranty upon request.



#### WATER QUALITY SYSTEMS

EVERPURE-SHURFLO WORLD HEADQUARTERS, 1040 MUIRFIELD DRIVE, HANOVER PARK, IL 60133 USA • FOODSERVICE.PENTAIR.COM  
800.942.1153 MAIN (US ONLY) • 630.307.3000 MAIN • 630.307.3030 FAX • CSEVERPURE@PENTAIR.COM EMAIL

EVERPURE-SHURFLO AUSTRALIA, 1-21 MONASH DRIVE, DANDENONG SOUTH, VIC 3175, AUSTRALIA  
011.1300.576.190 TEL • 011.61.39.562.7237 FAX • AU.EVERPURE@PENTAIR.COM EMAIL

EVERPURE-SHURFLO CHINA, 21F CLOUD 9 PLAZA, NO 1118, SHANGHAI, 200052, CHINA  
86.21.3211.4588 TEL • 86.21.3211.4580 FAX • CHINA.WATER@PENTAIR.COM EMAIL

EVERPURE-SHURFLO INDIA, GREEN BOULEVARD, B-9/A, 7TH FLOOR - TOWER B SECTOR 62, NOIDA - 201301  
91.120.419.9444 TEL • 91.120.419.9400 FAX • INDIACUSTOMER@PENTAIR.COM EMAIL

EVERPURE-SHURFLO EUROPE, PENTAIR WATER BELGIUM BVBA, INDUSTRIEPARK WOLFSTEE, TOEKOMSTLAAN, 30 B-2200 HERENTALS, BELGIUM  
+32.(0).14.283.500 TEL • +32.(0).14.283.505 FAX • SALES@EVERPURE-EUROPE.COM EMAIL

EVERPURE-SHURFLO JAPAN INC., HASHIMOTO MN BLDG. 7F, 3-25-1 HASHIMOTO, MIDORI-KU, SAGAMIHARA-SHI KANAGAWA 252-0143, JAPAN  
81.(0)42.775.3011 TEL • 81.(0)42.775.3015 FAX • INFO@EVERPURE.CO.JP EMAIL

EVERPURE-SHURFLO SOUTHEAST ASIA, SOUTHEAST ASIA, 390 HAVELOCK ROAD, #04-01, KING'S CENTRE, SINGAPORE 169662  
65.6768.5800 TEL • 65.6737.5149 FAX • CSEVERPURE@PENTAIR.COM EMAIL

All Pentair trademarks and logos are owned by Pentair, Inc. or its affiliates. All other registered and unregistered trademarks and logos are the property of their respective owners. Because we are continuously improving our products and services, Pentair reserves the right to change specifications without prior notice. Pentair is an equal opportunity employer.