



EVERPURE® INSURICE® SINGLE PF-4SI SYSTEM

SEDIMENT FILTRATION (0.5 MICRON) FOR PREMIUM QUALITY WATER FOR ICE APPLICATIONS

Insurice Single PF-4SI System: EV9324-61
4SI Replacement Cartridge: EV9606-51
EC110 Prefilter Cartridge: EV9534-12



APPLICATIONS

- Ice Machines
- High Capacity
 - High Volume
 - High Flow

Everpure 4SI and 7SI Cartridges meet ASHRAE Standard 188P which is designed to prevent bacteria from entering and/or reproducing in a hospital water system

FEATURES • BENEFITS

Effectively filters dirt and particles as small as 1/2 micron in size by mechanical means

Utilizes depth filtration and Fibredyne™ media for superior dirt-holding capability

NSF/ANSI Standard 53 certified to reduce cysts such as *Cryptosporidium* and *Giardia* by mechanical means

Leaves chlorine and chloramines within water that is supplied to equipment which helps to reduce slime growth in ice machine and ice bin

Reduces ice machine maintenance, service costs and downtime caused by scale buildup which can result in the clogging of distribution lines, malfunction of probes, floats, pumps, solenoids and valves, and higher energy consumption (as tested by Everpure)

Sanitary cartridge replacement is simple, quick and clean; internal filter parts are never exposed to handling or contamination

INSTALLATION TIPS

Choose a mounting location suitable to support the full weight of the system when operating.

Never use saddle valve for connection.

Use 3/4" water line.

Do not connect system to water-cooled condenser.

Install vertically with cartridges hanging down and allow 2½" (6.35 cm) clearance below the cartridge for easy cartridge replacement.

Flush cartridges by running water through system for five (5) minutes at full flow.

OPERATION TIPS

Change cartridges on a regular six (6) month preventative maintenance program.

Change cartridges when capacity is reached or when flow becomes too slow.

Service flow rate must not exceed 2.0 gpm (7.57 Lpm).

Always flush the filter cartridge at time of installation and cartridge change.

Inspect Everpure EC110 Cartridge periodically to determine dirt load.

Replace Everpure EC110 Cartridge when dirt has penetrated through to the inner core of the cartridge.

SIZING

Service Flow Rate: 2.0 gpm (7.57 Lpm)

Rated Capacity: 15,000 gal (56,700 L) of particulate and scale reduction*

*Estimated. Actual capacity may vary depending on volume of particulate in incoming water.

EVERPURE® INSURICE® SINGLE PF-4SI SYSTEM

EV9324-61

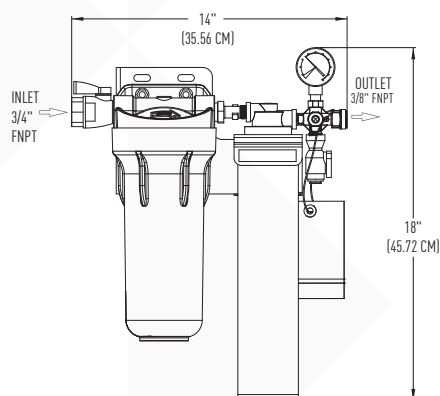

SPECIFICATIONS

Service Flow Rate

Maximum 2.0 gpm (7.57 Lpm)

Rated Capacity

15,000 gal (56,700 L) of particulate and scale reduction*

Pressure Requirements

10 - 125 psi (0.7 - 8.6 bar), non-shock

Temperature

35 - 100°F (2 - 38°C)

Overall Dimensions

18" L x 14" W x 6.47" D
(45.72 x 35.56 x 16.4 cm)

Inlet Connection

3/4"

Outlet Connection

3/8"

Shipping Weight

10 lbs (4.5 kgs)

Operating Weight

19 lbs (8.6 kgs)

Electrical Connection

None required

*Estimated. Actual capacity may vary depending on volume of particulate in incoming water.



System Tested and Certified by NSF International against NSF/ANSI Standards 42 and 53 for the reduction of:

STANDARD NO. 42 —
AESTHETIC EFFECTS

Mechanical Filtration
Nominal Particulate Class I

STANDARD NO. 53 —
HEALTH EFFECTS

Mechanical Filtration
Cyst

WARRANTY

Everpure water treatment systems by Pentair® (excluding replaceable elements) are covered by a limited warranty against defects in material and workmanship for a period of five years after date of purchase. Everpure replaceable elements (filter cartridges and water treatment cartridges) are covered by a limited warranty against defects in material and workmanship for a period of one year after date of purchase. See printed warranty for details. Pentair will provide a copy of the warranty upon request.

The contaminants or other substances removed or reduced by this drinking water system are not necessarily in your water. Do not use with water that is microbiologically unsafe or of unknown quality without adequate disinfection before or after the system. Systems certified for cyst reduction may be used with disinfected water that may contain filterable cysts.

EPA Est. No. 002623-IL-002



WATER QUALITY SYSTEMS

EVERPURE-SHURFLO WORLD HEADQUARTERS, 1040 MUIRFIELD DRIVE, HANOVER PARK, IL 60133 USA • FOODSERVICE.PENTAIR.COM
800.942.1153 (US ONLY) • 630.307.3000 MAIN • 630.307.3030 FAX • CSEVERPURE@PENTAIR.COM EMAIL

EVERPURE-SHURFLO AUSTRALIA, 1-21 MONASH DRIVE, DANDENONG SOUTH, VIC 3175 AUSTRALIA
011.1300 576 190 TEL • 011.61.39.562.7237 FAX • AU.EVERPURE@PENTAIR.COM EMAIL

EVERPURE-SHURFLO CHINA, 21F CLOUD 9 PLAZA, NO 1118, SHANGHAI, 200052, CHINA
86.21.3211.4588 TEL • 86.21.3211.4580 FAX • CHINA.WATER@PENTAIR.COM EMAIL

EVERPURE-SHURFLO INDIA, GREEN BOULEVARD, B-9/A, 7TH FLOOR - TOWER B SECTOR 62, NOIDA - 201301
91.120.419.9444 TEL • 91.120.419.9400 FAX • INDIACUSTOMER@PENTAIR.COM EMAIL

EVERPURE-SHURFLO EUROPE, PENTAIR WATER BELGIUM BVBA, INDUSTRIEPARK WOLFSTEE, TOEKOMSTLAAN 30, B-2200 HERENTALS, BELGIUM
+32.(0).14.283.504 TEL • +32.(0).14.283.505 FAX • SALES@EVERPURE-EUROPE.COM EMAIL

EVERPURE-SHURFLO JAPAN INC., HASHIMOTO MN BLDG. 7F, 3-25-1 HASHIMOTO, MIDORI-KU, SAGAMIHARA-SHI KANAGAWA 252-0143, JAPAN
81.(0)42.775.3011 TEL • 81.(0)42.775.3015 FAX • INFO@EVERPURE.CO.JP EMAIL

EVERPURE-SHURFLO SOUTHEAST ASIA, 390 HAVELOCK ROAD, #04-01 KING'S CENTRE, SINGAPORE 169662
65.6768.5800 TEL • 65.6737.5149 FAX • CSEVERPURE@PENTAIR.COM EMAIL

All Pentair trademarks and logos are owned by Pentair, Inc. or its affiliates. All other registered and unregistered trademarks and logos are the property of their respective owners. Because we are continuously improving our products and services, Pentair reserves the right to change specifications without prior notice. Pentair is an equal opportunity employer.