

# COLDRINK® 4 - 7FC SYSTEM

DELIVERS QUALITY WATER FOR HIGH-FLOW FOUNTAIN APPLICATIONS

Coldrink 4 - 7FC System EV9328-74  
7FC Replacement Cartridge: EV9692-61 (1 PK)  
EC210 Prefilter Cartridge: EV9534-26 (6 PK)



## APPLICATIONS

- ◆ Fountain beverage

## FEATURES • BENEFITS

- ◆ Enhances beverage quality, consistency, and retains carbonation
- ◆ Easy, sanitary, quick-change filter replacement
- ◆ Proprietary Pentair™ Everpure™ Fibredyne™ II media inhibits the growth of bacteria on the filter media that can decrease product life
- ◆ Exclusive Fibredyne™ II media provides chlorine taste & odor reduction and micro-filters dirt and particles as small as 0.2\* micron in size by mechanical means
- ◆ Balanced cartridge for optimum performance in varying water qualities
- ◆ Plate-mounted system allows for easy installation and startup
- ◆ Manifold features a water shutoff, flushing valve and outlet pressure gauge
- ◆ 20" prefilter reduces dirt and particles
- ◆ NSF/ANSI Standard 53 certified to reduce cysts such as *Cryptosporidium* and *Giardia* by mechanical means

## INSTALLATION TIPS

- ◆ Choose a mounting location suitable to support the full weight of the system when operating.
- ◆ Never use a saddle valve for connection.
- ◆ Use 3/4" water line.
- ◆ Do not connect system to water-cooled condenser.
- ◆ Install vertically with cartridges hanging down and allow 2½" (6.35 cm) clearance below the cartridge for easy cartridge replacement.
- ◆ Flush cartridges by running water through system for five (5) minutes at full flow.

## OPERATION TIPS

- ◆ Change cartridges on a regular six (6) month preventative maintenance program.
- ◆ Change cartridges when capacity is reached or when pressure falls below 10 psi (0.7 bar).
- ◆ Always flush the filter cartridge at time of installation and cartridge change.
- ◆ Inspect Pentair Everpure EC210 cartridge periodically to determine dirt load.
- ◆ Replace EC210 cartridge when dirt has penetrated through to the inner core of the cartridge.

## SIZING

- ◆ Service Flow Rate:  
Maximum 10.0 gpm (37.85 Lpm)
- ◆ Rated Capacity:  
100,000 gallons (378,541 L)

\*Validated by ISO 17025 accredited lab for 99.999% reduction of *Pseudomonas diminuta* following the ASTM F838-05 protocol for the validation of 0.2 µm sterilizing grade filters.

EPA Est. No. 002623-IL-002

# COLDRINK 4 - 7FC SYSTEM

EV9328-74

Coldrink 4 - 7FC System EV9328-74  
7FC Replacement Cartridge: EV9692-61 (1 PK)  
EC210 Prefilter Cartridge: EV9534-26 (6 PK)

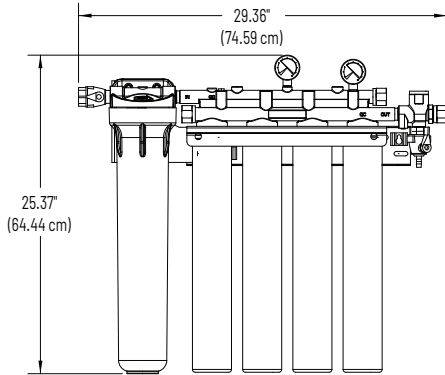

## SPECIFICATIONS

- ◆ **Service Flow Rate**  
Maximum 10.0 gpm (37.85 Lpm)
- ◆ **Rated Capacity**  
100,000 gallons (378,541 L)
- ◆ **Pressure Requirements**  
10 - 125 psi (0.7 - 8.6 bar), non-shock
- ◆ **Temperature Limits**  
35 - 100°F (2 - 38°C)
- ◆ **Overall Dimensions**  
29.36" H x 25.37" W x 6.04" D  
(74.59 x 64.44 x 15.3 cm)
- ◆ **Inlet Connection** 3/4"
- ◆ **Outlet Connection** 3/4"
- ◆ **Electrical Connection**  
None
- ◆ **Shipping Weight**  
43 lbs (19.5 kgs)
- ◆ **Operating Weight**  
55 lbs (24.95 kgs)

The contaminants or other substances removed or reduced by this drinking water system are not necessarily in your water. Do not use with water that is microbiologically unsafe or of unknown quality without adequate disinfection before or after the system.

Since the conditions under which our products may be used are beyond our control, we cannot accept any liability with respect to the improper installation, application and/or use of our products.

For Pentair Everpure Product Warranties visit:  
<http://pentair.com/assets/foodservice-warranty>



SYSTEM TESTED AND CERTIFIED BY NSF INTERNATIONAL AGAINST NSF/ ANSI STANDARDS 42 AND 53 FOR THE REDUCTION OF:	
STANDARD NO. 42 – AESTHETIC EFFECTS	STANDARD NO. 53 – HEALTH EFFECTS
Chemical Reduction	Mechanical
Taste & Odor	Filtration
Chlorine	Cyst
Mechanical Filtration	Turbidity
Nominal Particulate Class I	

**United States** | 1040 Muirfield Drive | Hanover Park, IL 60133 | 800.942.1153 (US Only) 630.307.3000 Main | [cseverpure@pentair.com](mailto:cseverpure@pentair.com) | [foodservice.pentair.com](http://foodservice.pentair.com)  
**Australia** | 1-21 Monash Drive | Dandenong South, Vic 3175 | Australia | 011.1300 576 190 Tel | [au.everpure@pentair.com](mailto:au.everpure@pentair.com)  
**China** | 21F Cloud 9 Plaza, N0 1118 | Shanghai, 200052 | China | 86.21.3211.4588 Tel | [china.water@pentair.com](mailto:china.water@pentair.com)  
**India** | Boulevard, B-9/A, 7th Floor - Tower B Sector 62 | Noida - 201301 | 91.120.419.9444 Tel | [indiacustomer@pentair.com](mailto:indiacustomer@pentair.com)  
**Europe** | Pentair Water Belgium BVBA | Industriepark Wolfstee, Toekomstlaan 30, B-2200 Herentals | Belgium | +32.(0).14.283.504 Tel | [sales@everpure-europe.com](mailto:sales@everpure-europe.com)  
**Japan** | Japan Inc. | Hashimoto MN Bldg. 7F, | 3-25-1 Hashimoto, Midori-ku, Sagamihara-shi | Kanagawa 252-0143 | Japan | 81.(0)42.775.3011 Tel | [info@everpure.co.jp](mailto:info@everpure.co.jp)  
**Southeast Asia** | 390 Havelock Road, | #04-01 King's Centre | Singapore 169662 | 65.6768.5800 Tel | [cseverpure@pentair.com](mailto:cseverpure@pentair.com)

All indicated Pentair trademarks and logos are property of Pentair. Third party registered and unregistered trademarks and logos are the property of their respective owners