



# EVERPURE® PARALLEL 202 PREFILTER KIT

HIGH-VOLUME PREFILTER SYSTEM MAXIMIZES LIFE OF SUBMICRON FILTERS

Parallel 202 Prefilter Kit: EV9336-52  
EC204 Replacement Cartridge: EV9108-40  
Parallel 202 Without Surge Tank: EV9100-24  
Extra Capacity Surge Tank: EV9336-51

## APPLICATIONS

Add-on Components Address High Particulate, Algae and Other Related Water Issues

High-Volume Combination Applications  
Extends The Life Of Submicron Filters



## FEATURES • BENEFITS

Delivers quality water to high volume fountain dispensers, coffee makers and ice machines where extreme water conditions demand larger capacity filters

Extends the life of submicron filter system cartridges

Special dual gradient prefilter cartridges reduce dirt and other particles at least 10-microns in size

Ideal for water supplies with excessive dirt loads

Additional draw down capacity for high volume locations and peak demand times

Parallel 4" x 20" sumps hold high efficiency cartridges

Built-in water meter determines water demand and usage for all equipment

Includes fittings for connections to existing Everpure filtration systems

Allows for 12-gallon reserve of filtered water

## INSTALLATION TIPS

Never use saddle valve for connection.

Use 3/4" water line.

Do not connect system to water-cooled condenser.

Install vertically with bowls hanging down.

Allow 2-1/2" (6.35 cm) clearance below the cartridge for easy cartridge replacement.

Flush cartridges by running water through system for five (5) minutes at full flow.

## OPERATION TIPS

Change cartridges on a regular six (6) month preventative maintenance program.

Change cartridges when capacity is reached or when pressure falls below 10 psi (0.7 bar).

Service flow rate must not exceed 10 gpm (37.8 Lpm).

Always flush the filter cartridge at time of installation and cartridge change.

## SIZING

Service Flow Rate: Maximum 10 gpm (37.8 Lpm)

# EVERPURE® PARALLEL 202 PREFILTER KIT

## EV9336-52

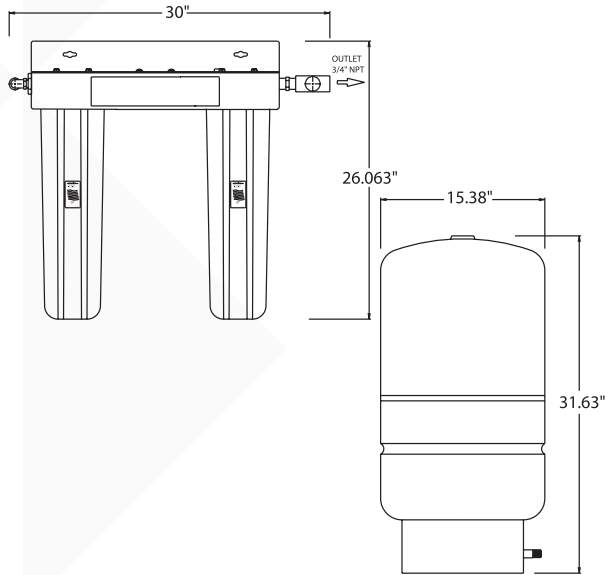

The contaminants or other substances removed or reduced by this drinking water system are not necessarily in your water. Do not use with water that is microbiologically unsafe or of unknown quality without adequate disinfection before or after the system.

### WARRANTY

Everpure water treatment systems by Pentair® (excluding replaceable elements) are covered by a limited warranty against defects in material and workmanship for a period of five years after date of purchase. Everpure replaceable elements (filter cartridges and water treatment cartridges) are covered by a limited warranty against defects in material and workmanship for a period of one year after date of purchase. See printed warranty for details. Pentair will provide a copy of the warranty upon request.



### WATER QUALITY SYSTEMS

EVERPURE-SHURFLO WORLD HEADQUARTERS, 1040 MUIRFIELD DRIVE, HANOVER PARK, IL 60133 USA • FOODSERVICE.PENTAIR.COM  
800.942.1153 MAIN (US ONLY) • 630.307.3000 MAIN • 630.307.3030 FAX • CSEVERPURE@PENTAIR.COM EMAIL

EVERPURE-SHURFLO AUSTRALIA, 1-21 MONASH DRIVE, DANDENONG SOUTH, VIC 3175, AUSTRALIA  
011.1300.576.190 TEL • 011.61.39.562.7237 FAX • AU.EVERPURE@PENTAIR.COM EMAIL

EVERPURE-SHURFLO CHINA, 21F CLOUD 9 PLAZA, NO 1118, SHANGHAI, 200052, CHINA  
86.21.3211.4588 TEL • 86.21.3211.4580 FAX • CHINA.WATER@PENTAIR.COM EMAIL

EVERPURE-SHURFLO INDIA, GREEN BOULEVARD, B-9/A, 7TH FLOOR - TOWER B SECTOR 62, NOIDA - 201301  
91.120.419.9444 TEL • 91.120.419.9400 FAX • INDIACUSTOMER@PENTAIR.COM EMAIL

EVERPURE-SHURFLO EUROPE, PENTAIR WATER BELGIUM BVBA, INDUSTRIEPARK WOLFSTEE, TOEKOMSTLAAN, 30 B-2200 HERENTALS, BELGIUM  
+32.(0).14.283.500 TEL • +32.(0).14.283.505 FAX • SALES@EVERPURE-EUROPE.COM EMAIL

EVERPURE-SHURFLO JAPAN INC., HASHIMOTO MN BLDG. 7F, 3-25-1 HASHIMOTO, MIDORI-KU, SAGAMIHARA-SHI KANAGAWA 252-0143, JAPAN  
81.(0)42.775.3011 TEL • 81.(0)42.775.3015 FAX • INFO@EVERPURE.CO.JP EMAIL

EVERPURE-SHURFLO SOUTHEAST ASIA, SOUTHEAST ASIA, 390 HAVELOCK ROAD, #04-01, KING'S CENTRE, SINGAPORE 169662  
65.6768.5800 TEL • 65.6737.5149 FAX • CSEVERPURE@PENTAIR.COM EMAIL

All Pentair trademarks and logos are owned by Pentair, Inc. or its affiliates. All other registered and unregistered trademarks and logos are the property of their respective owners. Because we are continuously improving our products and services, Pentair reserves the right to change specifications without prior notice. Pentair is an equal opportunity employer.

### SPECIFICATIONS

#### Service Flow Rate

Maximum 10 gpm (37.8 Lpm)

#### Pressure Requirements

10 – 90 psi (0.7 – 6.2 bar), non-shock

#### Temperature

35 – 100°F (2 – 38°C)

#### Overall Dimensions

26.125" H x 23.25" W x 8.5" D  
(66.3 cm x 59 cm x 21.5 cm)

#### Inlet Connection

3/4"

#### Outlet Connection

3/4"

#### Electrical Connection

None Required

#### Shipping Weight

Prefilter 32.5 lbs (14.7 kgs)

Surge Tank 35 lbs (15.8 kgs)

#### Operating Weight

Prefilter 41.5 lbs (18.8 kgs)

Surge Tank 133 lbs (60.3 kgs)