



EVERPURE® FC10 & FC20 FILTER CARTRIDGES

DELIVER PREMIUM QUALITY WATER FOR FOUNTAIN APPLICATIONS

FC10 Cartridge 12 PK: EV9537-10

FC20 Cartridge 12 PK: EV9537-20



APPLICATIONS

Fountain

FEATURES • BENEFITS

Drop-in cartridges for taste, odor, sediment and cyst reduction by mechanical means

Exclusive Fibredyne™ II media provides a superior balance of chlorine, taste & odor reduction, and dirt-holding capabilities for particles as small as 1/2-micron size by mechanical means

NSF/ANSI Standard 53 certified to reduce cysts such as *Cryptosporidium* and *Giardia* by mechanical means

Reduce chlorine taste & odor and other offensive contaminants that can adversely affect the taste of beverages

Protect drink system seals, pump, tubing and small orifices from clogging, corrosion and abrasive wear

Improve the taste of fountain beverages and helps retain the drink's carbonation

Increased capacity for extended reduction of chemical and mechanical contaminants

Balanced cartridge for optimum performance in varying water qualities

Compatible with E10 and E20 housings

INSTALLATION TIPS

Install vertically so bowls hang down.

Allow 2-1/2" (6.35 cm) clearance below the cartridge for easy cartridge replacement.

Flush cartridge by running water through system for five (5) minutes at full flow.

Inspect O-ring during each cartridge change. Lubricate and/or replace if necessary.

OPERATION TIPS

Replace cartridge when flow rate becomes inconveniently slow or before rated capacity is reached. It is recommended to replace cartridge at least once per year.

Change cartridges when capacity is reached or when pressure falls below 10 psi (0.7 bar).

Always flush the filter cartridge at time of installation and cartridge change.

SIZING

Service Flow Rate:

FC10 1.5 gpm (5.67 lpm) recommended

FC20 2.5 gpm (9.46 lpm) recommended

Rated Capacity:

FC10: 15,000 gallons (56,781 L)

FC20: 25,000 gallons (94,635 L)

EVERPURE® FC10 & FC20 FILTER CARTRIDGES

EV9537-10 • EV9537-20

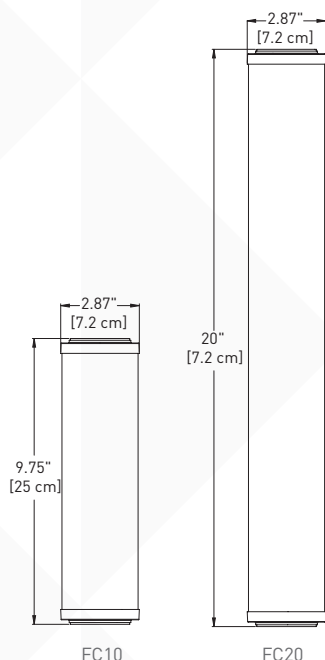

SPECIFICATIONS

Service Flow Rate

FC10 1.5 gpm (5.67 lpm) recommended
 FC20 2.5 gpm (9.46 lpm) recommended

Rated Capacity

FC10: 15,000 gallons (56,781 L)
 FC20: 25,000 gallons (94,635 L)

Pressure Requirements

10 - 125 psi (0.7 - 8.6 bar), non-shock

Temperature

35 - 100°F (2 - 38°C)

FC10 Overall Dimensions

9.75" L x 2.87" dia. (25 x 7.2 cm)

FC20 Overall Dimensions

20" L x 2.87" dia. (50.7 x 7.2 cm)

Electrical Connection

None required



Cartridges Tested and Certified by NSF International against NSF/ANSI Standards 42 and 53 for the reduction of:

STANDARD NO. 42 – AESTHETIC EFFECTS

- Chemical Reduction
- Taste & Odor
- Chlorine

Mechanical Filtration
 Nominal Particulate Class I

STANDARD NO. 53 – HEALTH EFFECTS

- Mechanical Filtration
- Turbidity
- Cyst

WARRANTY

Everpure water treatment systems by Pentair® (excluding replaceable elements) are covered by a limited warranty against defects in material and workmanship for a period of five years after date of purchase. Everpure replaceable elements (filter cartridges and water treatment cartridges) are covered by a limited warranty against defects in material and workmanship for a period of one year after date of purchase. See printed warranty for details. Pentair will provide a copy of the warranty upon request.

EPA Est. No. 086074-NH-001

The contaminants or other substances removed or reduced by this drinking water system are not necessarily in your water. Do not use with water that is microbiologically unsafe or of unknown quality without adequate disinfection before or after the system. Systems certified for cyst reduction may be used with disinfected water that may contain filterable cysts.



WATER QUALITY SYSTEMS

EVERPURE-SHURFLO WORLD HEADQUARTERS, 1040 MUIRFIELD DRIVE, HANOVER PARK, IL 60133 USA • FOODSERVICE.PENTAIR.COM
 800.942.1153 (US ONLY) • 630.307.3000 MAIN • 630.307.3030 FAX • CSEVERPURE@PENTAIR.COM EMAIL

EVERPURE-SHURFLO AUSTRALIA, 1-21 MONASH DRIVE, DANDENONG SOUTH, VIC 3175 AUSTRALIA
 011.1300.576.190 TEL • 011.61.39.562.7237 FAX • AU.EVERPURE@PENTAIR.COM EMAIL

EVERPURE-SHURFLO CHINA, 21F CLOUD 9 PLAZA, NO 1118, SHANGHAI, 200052, CHINA
 86.21.3211.4588 TEL • 86.21.3211.4580 FAX • CHINA.WATER@PENTAIR.COM EMAIL

EVERPURE-SHURFLO INDIA, GREEN BOULEVARD, B-9/A, 7TH FLOOR - TOWER B SECTOR 62, NOIDA - 201301
 91.120.419.9444 TEL • 91.120.419.9400 FAX • INDIACUSTOMER@PENTAIR.COM EMAIL

EVERPURE-SHURFLO EUROPE, PENTAIR WATER BELGIUM BVBA, INDUSTRIEPARK WOLFSTEE, TOEKOMSTLAAN 30, B-2200 HERENTALS, BELGIUM
 +32.(0).14.283.504 TEL • +32.(0).14.283.505 FAX • SALES@EVERPURE-EUROPE.COM EMAIL

EVERPURE-SHURFLO JAPAN INC., HASHIMOTO MN BLDG. 7F, 3-25-1 HASHIMOTO, MIDORI-KU, SAGAMIHARA-SHI KANAGAWA 252-0143, JAPAN
 81.(0)42.775.3011 TEL • 81.(0)42.775.3015 FAX • INFO@EVERPURE.CO.JP EMAIL

EVERPURE-SHURFLO SOUTHEAST ASIA, 390 HAVELOCK ROAD, #04-01 KING'S CENTRE, SINGAPORE 169662
 65.6768.5800 TEL • 65.6737.5149 FAX • CSEVERPURE@PENTAIR.COM EMAIL

All Pentair trademarks and logos are owned by Pentair, Inc. or its affiliates. All other registered and unregistered trademarks and logos are the property of their respective owners. Because we are continuously improving our products and services, Pentair reserves the right to change specifications without prior notice. Pentair is an equal opportunity employer.