

EVERPURE® KLEENWARE® HTS-11 SYSTEM

SCALE PREVENTION AND CORROSION CONTROL FOR WAREWASHING EQUIPMENT

Kleenware HTS-11 System: EV9799-11
HT-10 Replacement Cartridge: EV9799-22



APPLICATIONS

Commercial dishwashers
Commercial glassware washers
Warewashing booster heaters

FEATURES • BENEFITS

Scale control system features HydroBlend™

Opaque (red) high temperature bowl allows for hot water [up to 170°F (76.6°C)] feed installations

Transparent replacement cartridge containing HydroBlend™ scale inhibitor, which is effective up to 200°F (93.3°C)

Specially designed flow through head assures consistent, predictable product feed rates

Inhibits mineral deposits and provides corrosion protection

Extends the life of expensive foodservice equipment

INSTALLATION TIPS

The HTS-11 system must be used as a unit (i.e. high temperature bowl, head and cartridge)

Install vertically using the mounting bracket provided

Use 3/4" water line and observe proper inlet/outlet water directions

Some pressure relief mechanism should be provided downstream of the system to permit releasing line pressure when changing cartridges

Delimiting of equipment prior to installation is recommended, but not required

OPERATION TIPS

Inspect HT-10 cartridge at least every six (6) months for replacement

Pre-existing equipment scale may be dislodged and settle to the bottom of a chamber which can clog drain initially. Remove any settled scale

In new installations, the HydroBlend™ usage rate may start high, but will reduce as existing scale is removed

Replace HT-10 cartridge before HydroBlend™ compound is completely used up

SIZING

Service Flow Rate: Maximum 15 gpm (56.8 Lpm)

EVERPURE® KLEENWARE® HTS-11 SYSTEM

EV9799-11

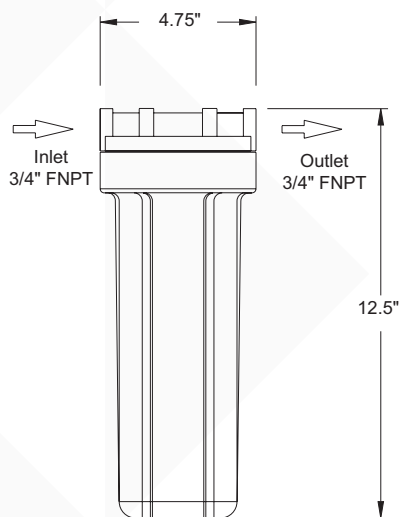

SPECIFICATIONS

Overall Dimensions

12.5" L x 4.75" W x 4.625" D
(31.7 x 12 x 11.7 cm)

Connections

Inlet Connection: 3/4"

Outlet Connection: 3/4"

Service Flow Rate

Maximum 15 gpm (56.8 Lpm)

Pressure Requirements

10 - 200 psi (0.7 - 13.6 bar), non-shock

Temperature

170°F (77°C)

Operating Weight

8 lbs (3.6 kg)

Shipping Weight

7 lbs (3.1 kg)

Electrical Connection

None required

The contaminants or other substances removed or reduced by this drinking water system are not necessarily in your water. Do not use with water that is microbiologically unsafe or of unknown quality without adequate disinfection before or after the system. Systems certified for cyst reduction may be used with disinfected water that may contain filterable cysts.

WARRANTY

Everpure water treatment systems by Pentair® (excluding replaceable elements) are covered by a limited warranty against defects in material and workmanship for a period of five years after date of purchase. Everpure replaceable elements (filter cartridges and water treatment cartridges) are covered by a limited warranty against defects in material and workmanship for a period of one year after date of purchase. See printed warranty for details. Pentair will provide a copy of the warranty upon request.



FILTRATION & PROCESSING SOLUTIONS

EVERPURE-SHURFLO WORLD HEADQUARTERS, 1040 MUIRFIELD DRIVE, HANOVER PARK, IL 60133 USA • WWW.EVERPURE.COM
800.942.1153 MAIN (US ONLY) • 630.307.3000 MAIN • 630.307.3030 FAX • CSEVERPURE@PENTAIR.COM EMAIL

EVERPURE-SHURFLO AUSTRALIA / NEW ZEALAND, 1-21 MONASH DRIVE, DANDENONG SOUTH, VIC, 3175, AUSTRALIA
1300.576.190 TEL • AU.EVERPURE@PENTAIR.COM EMAIL

EVERPURE-SHURFLO CHINA, 21F CLOUD 9 PLAZA, NO 1118, SHANGHAI, 200052, CHINA
86.21.3211.4588 TEL • 86.21.3211.4580 FAX • CHINA.WATER@PENTAIR.COM EMAIL

EVERPURE-SHURFLO INDIA, GREEN BOULEVARD, B-9/A, 7TH FLOOR - TOWER B SECTOR 62, NOIDA - 201301
91.120.419.9444 TEL • 91.120.419.9400 FAX • INDIACUSTOMER@PENTAIR.COM EMAIL

EVERPURE-SHURFLO EUROPE, PENTAIR WATER BELGIUM BVBA, INDUSTRIEPARK WOLFSTEE, TOEKOMSTLAAN, 30 B-2200 HERENTALS, BELGIUM
+32.(0).14.283.500 TEL • +32.(0).14.283.505 FAX • SALES@EVERPURE-EUROPE.COM EMAIL

EVERPURE-SHURFLO JAPAN INC., HASHIMOTO MN BLDG. 7F, 3-25-1 HASHIMOTO, MIDORI-KU, SAGAMIHARA-SHI KANAGAWA 252-0143, JAPAN
81.(0)42.775.3011 TEL • 81.(0)42.775.3015 FAX • INFO@EVERPURE.CO.JP EMAIL

EVERPURE-SHURFLO SOUTHEAST ASIA, 390 HAVELOCK ROAD, #04-01, KING'S CENTRE, SINGAPORE 169662
65.6795.2213 TEL • FAX: 65.6795.2219 FAX • CSEVERPURE@PENTAIR.COM EMAIL

All Pentair trademarks and logos are owned by Pentair, Inc. All other brand or product names are trademarks or registered marks of their respective owners. Because we are continuously improving our products and services, Pentair reserves the right to change specifications without prior notice. Pentair is an equal opportunity employer.