



EVERPURE® ENDURANCE® HIGH FLOW TRIPLE SYSTEM

DELIVERS PREMIUM QUALITY WATER FOR HIGH VOLUME COMBINATION APPLICATIONS

Endurance High Flow Triple: EV9437-31
Endurance Triple Cartridge Kit: EV9628-71*

* not shown



APPLICATIONS

Multiple Equipment and Combination Applications

High-Volume Installations

FEATURES • BENEFITS

High capacity allows system to keep up high water demands and allows longer periods between replacing filter cartridges

Unique pretreatment system features pleated membrane with a large surface area

Sanitary cartridge replacement is simple, quick and clean; internal filter parts are never exposed to handling or contamination

Exclusive Fibredyne™ II media provides superior chlorine taste & odor reduction and micro-filters dirt and particles as small as 0.2[†] micron in size by mechanical means

Compact design nearly the same footprint as the Everpure High Flow CSR Quad System

Outstanding dirt-holding capabilities

Utilizes Everpure Phosphate Cartridge for scale reduction

NSF/ANSI Standard 53 certified to reduce cysts such as *Cryptosporidium* and *Giardia* by mechanical means

[†] Validated by ISO 17025 accredited lab for 99.999% reduction of *Pseudomonas diminuta* following the ASTM F838-05 protocol for the validation of 0.2 µm sterilizing grade filters

INSTALLATION TIPS

Choose a mounting location capable of safely supporting the full weight of the system when in operation.

Use 3/4" water line.

Fountain equipment connections are made to the outlet part of the system before the Everpure 2SR-BW Cartridge.

Coffee brewer and ice machine connections are made after the Everpure 2SR-BW Scale Inhibitor Cartridge; a tee is required.

Install vertically with cartridges hanging down and allow 5" (12.7 cm) clearance below the cartridge for easy replacement.

Frame is designed to mount on 16" centers (wall studs).

OPERATION TIPS

Change filter cartridges on a regular 12-month preventative maintenance program.

Change cartridges when capacity is reached or when flow becomes too slow, but at least annually.

Always flush the filter cartridge at time of installation and cartridge change.

Flush cartridges by running water through flushing valve for five (5) minutes at full flow.

SIZING

Rated Service Flow: 11.25 gpm (42.6 lpm)

Rated Capacity: Up to 150,000 gallon (567,810 L)

EVERPURE® ENDURANCE® HIGH FLOW TRIPLE SYSTEM EV9437-31

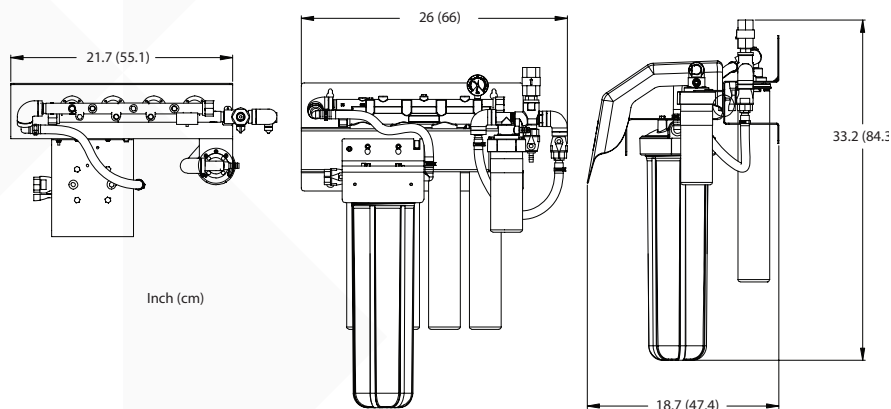

System Tested and Certified by NSF International against NSF/ANSI Standards 42 and 53 for the reduction of:

STANDARD NO. 42 –
AESTHETIC EFFECTS

- Bacteriostatic Effects
- Chemical Reduction
Taste and Odor
Chlorine
- Mechanical Filtration
Nominal Particulate Class I

STANDARD NO. 53 –
HEALTH EFFECTS

- Mechanical Filtration
Cyst

SPECIFICATIONS

Rated Capacity

Up to 150,000 gallon (567,810L) or one year

Rated Service Flow

11.25 gpm (42.6 lpm)

Pressure Requirements

10 - 100 psi (0.7 – 6.9 bar), non-shock

Temperature

35 - 100°F (2 - 38°C)

Overall Dimensions

33.2" H x 26" W x 18.7" D
(84.3 cm x 66 cm x 47.4 cm)

Connections

3/4"

Shipping Weight

46 lbs (20.87 kgs)

Operating Weight

63.8 lbs (28.9 kgs)

Electrical Connection

None required

EPA No. 002623-IL-002

The contaminants or other substances removed or reduced by this drinking water system are not necessarily in your water. Do not use with water that is microbiologically unsafe or of unknown quality without adequate disinfection before or after the system. Systems certified for cyst reduction may be used with disinfected water that may contain filterable cysts.

Since the conditions under which our products may be used are beyond our control, we cannot accept any liability with respect to the improper installation, application and/or use of our products.

WARRANTY

Everpure water treatment systems by Pentair® (excluding replaceable elements) are covered by a limited warranty against defects in material and workmanship for a period of five years after date of purchase. Everpure replaceable elements (filter cartridges and water treatment cartridges) are covered by a limited warranty against defects in material and workmanship for a period of one year after date of purchase. See printed warranty for details. Pentair will provide a copy of the warranty upon request.



WATER QUALITY SYSTEMS

EVERPURE-SHURFLO WORLD HEADQUARTERS, 1040 MUIRFIELD DRIVE, HANOVER PARK, IL 60133 USA • FOODSERVICE.PENTAIR.COM
800.942.1153 (US ONLY) • 630.307.3000 MAIN • 630.307.3030 FAX • CSEVERPURE@PENTAIR.COM EMAIL

EVERPURE-SHURFLO AUSTRALIA, 1-21 MONASH DRIVE, DANDENONG SOUTH, VIC 3175 AUSTRALIA
011.1300 576 190 TEL • 011.61.39.562.7237 FAX • AU.EVERPURE@PENTAIR.COM EMAIL

EVERPURE-SHURFLO CHINA, 21F CLOUD 9 PLAZA, NO 1118, SHANGHAI, 200052, CHINA
86.21.3211.4588 TEL • 86.21.3211.4580 FAX • CHINA.WATER@PENTAIR.COM EMAIL

EVERPURE-SHURFLO INDIA, GREEN BOULEVARD, B-9/A, 7TH FLOOR - TOWER B SECTOR 62, NOIDA - 201301
91.120.419.9444 TEL • 91.120.419.9400 FAX • INDIACUSTOMER@PENTAIR.COM EMAIL

EVERPURE-SHURFLO EUROPE, PENTAIR WATER BELGIUM BVBA, INDUSTRIEPARK WOLFSTEE, TOEKOMSTLAAN 30, B-2200 HERENTALS, BELGIUM
+32.(0).14.283.504 TEL • +32.(0).14.283.505 FAX • SALES@EVERPURE-EUROPE.COM EMAIL

EVERPURE-SHURFLO JAPAN INC., HASHIMOTO MN BLDG. 7F, 3-25-1 HASHIMOTO, MIDORI-KU, SAGAMIHARA-SHI KANAGAWA 252-0143, JAPAN
81.(0)42.775.3011 TEL • 81.(0)42.775.3015 FAX • INFO@EVERPURE.CO.JP EMAIL

EVERPURE-SHURFLO SOUTHEAST ASIA, 390 HAVELOCK ROAD, #04-01 KING'S CENTRE, SINGAPORE 169662
65.6768.5800 TEL • 65.6737.5149 FAX • CSEVERPURE@PENTAIR.COM EMAIL

All Pentair trademarks and logos are owned by Pentair, Inc. or its affiliates. All other registered and unregistered trademarks and logos are the property of their respective owners. Because we are continuously improving our products and services, Pentair reserves the right to change specifications without prior notice. Pentair is an equal opportunity employer.