

CGS-22 20" DUAL SERIES HOUSING

FOODSERVICE SYSTEM HOUSING FOR DROP-IN CARTRIDGES

CGS-22 20" Dual Series Housing: EV9100-22



APPLICATIONS

- ◆ Foodservice

FEATURES • BENEFITS

- ◆ 20" low profile Slim Line™ dual bowl housing in series configuration
- ◆ Manufactured of durable polypropylene
- ◆ System includes water pressure gauge
- ◆ Includes wall mounting bracket and hardware for fast and easy installation
- ◆ System is shipped fully assembled
- ◆ Choose the appropriate cartridges for your needs
- ◆ Cartridges sold separately
- ◆ Bowl housing assembly accepts drop-in cartridges
- ◆ Has excellent chemical resistance
- ◆ Equipped with a pressure relief button to relieve water pressure during cartridge changes

INSTALLATION TIPS

- ◆ Choose a mounting location suitable to support the full weight of the system when operating
- ◆ Install vertically so bowls hang down
- ◆ Allow 2½" (6.35 cm) clearance below the cartridge for easy cartridge replacement
- ◆ Make sure o-ring on bowl is sufficiently lubricated
- ◆ Always screw on bowls by hand; do not use a housing wrench
- ◆ Flush filter by running water through filter according to cartridge instructions

OPERATION TIPS

- ◆ Change cartridges on a regular six (6) month preventative maintenance program
- ◆ Change cartridges when capacity is reached or when pressure decreases
- ◆ Always inspect o-ring; change and/or lubricate if necessary
- ◆ Clean bowl with mild solution of detergent before inserting new cartridge
- ◆ Always flush the filter cartridge at time of installation and cartridge change

SIZING

- ◆ Rated Capacity:
Varies according to filter used
- ◆ Service Flow Rate:
Maximum 4 gpm (15.1 Lpm)

CGS-22 20" DUAL SERIES HOUSING

EV9100-22

CGS-22 20" Dual Series Housing: EV9100-22

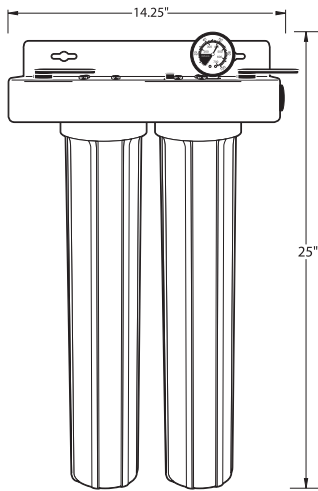

SPECIFICATIONS

- ◆ **Overall Dimensions**
25" H x 14.25" W x 5.25" D
(63.5 x 36.1 x 13.3 cm)
- ◆ **Connections**
Inlet Connection: 1/2"
Outlet Connection: 1/2"
- ◆ **Rated Capacity**
Varies according to filter used
- ◆ **Service Flow Rate**
Maximum 4 gpm (15.1 Lpm)
- ◆ **Pressure Requirements**
30 - 125 psi (2.1 - 8.6 bar), non-shock
- ◆ **Temperature**
40 - 100°F (4.4 - 38°C)
- ◆ **Electrical Connection**
None required

WARRANTY

EVERPURE® Product Warranties visit:
www.pentair.com/assets/foodservice-warranty

The contaminants or other substances removed or reduced by this drinking water system are not necessarily in your water. Do not use with water that is microbiologically unsafe or of unknown quality without adequate disinfection before or after the system. Systems certified for cyst reduction may be used with disinfected water that may contain filterable cysts.

Since the conditions under which our products may be used are beyond our control, we cannot accept any liability with respect to the improper installation, application and/or use of our products.



1040 Muirfield Drive
Hanover Park, IL 60133
United States
800.942.1153 (US Only)
630.307.3000 Main
cseverpure@pentair.com

Australia
1-21 Monash Drive
Dandenong South, Vic 3175
Australia
011.1300 576 190 Tel
au.everpure@pentair.com

China
21F Cloud 9 Plaza, NO 1118
Shanghai, 200052
China
86.21.3211.4588 Tel
china.water@pentair.com

India
Boulevard, B-9/A,
7th Floor - Tower B Sector 62
Noida - 201301
91.120.419.9444 Tel
indiacustomer@pentair.com

Europe
Pentair Water Belgium BVBA
Industriepark Wolfstee,
Toekomstlaan 30,
B-2200 Herentals
Belgium
+32.(0)14.283.504 Tel
sales@everpure-europe.com

Japan Inc.
Hashimoto MN Bldg. 7F,
3-25-1 Hashimoto, Midori-ku,
Sagamihara-shi
Kanagawa 252-0143
Japan
81.(0)42.775.3011 Tel
info@everpure.co.jp

Southeast Asia
390 Havelock Road,
#04-01 King's Centre
Singapore 169662
65.6768.5800 Tel
cseverpure@pentair.com