

PARTS LIST

ITEM	PART NO.	DESCRIPTION	REQ'D
1	11877	SHAFT	1
2	12622	NO. 9 NON-ROK KEY	1
3	4258	RET. RING EXT.	3
4	4259	RET. RING INT.	2
5	4991	3/8 STD. LOCK WASHER	2
6	12314	MECH SEAL	1
7	12256	SEAL SEAT	1
8	11633	CAP SCREW 3/8-16x3/4	2
9	P-12710	1/4 LIGHT LOCK WASHER	3
10	12857	CAP SCREW 1/4-20x7/8	3
11	12856	END RATE	1
12	10515	SCREW 1/4-20x3/8	1
13	10944	CAM (180)	1
14	10615	IMPELLER	1
15	12902	HOUSING	1
16	12393	MOUNTING BRACKET	1
17	4264	THRUST WASHER	1
18	12251	O' RING	1
19	12855	GASKET	1
20	5133	SPACER BRG	1
21	12227	BODY	1
22	12211	BALL BRG.	2
23	4432	NO. 9 WOODRUFF KEY	1
24	17653	JEFFY BAG N#5	1
25	17659	CARTON Y	1
26	12209	LABEL	1

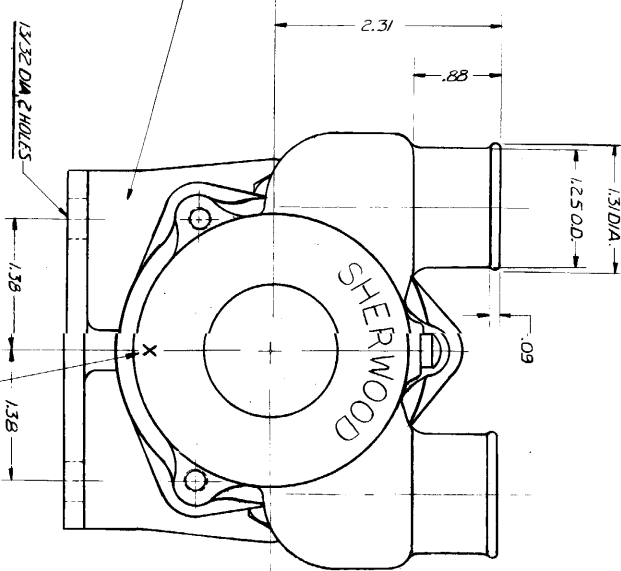
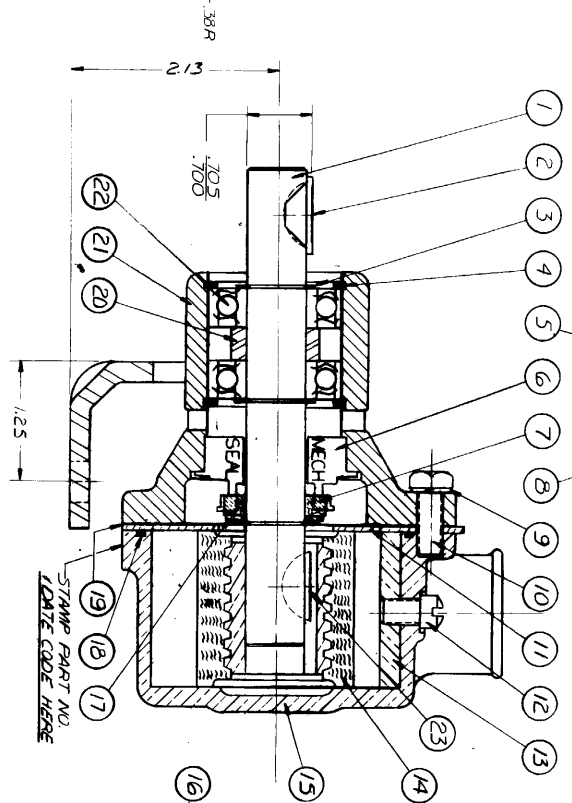
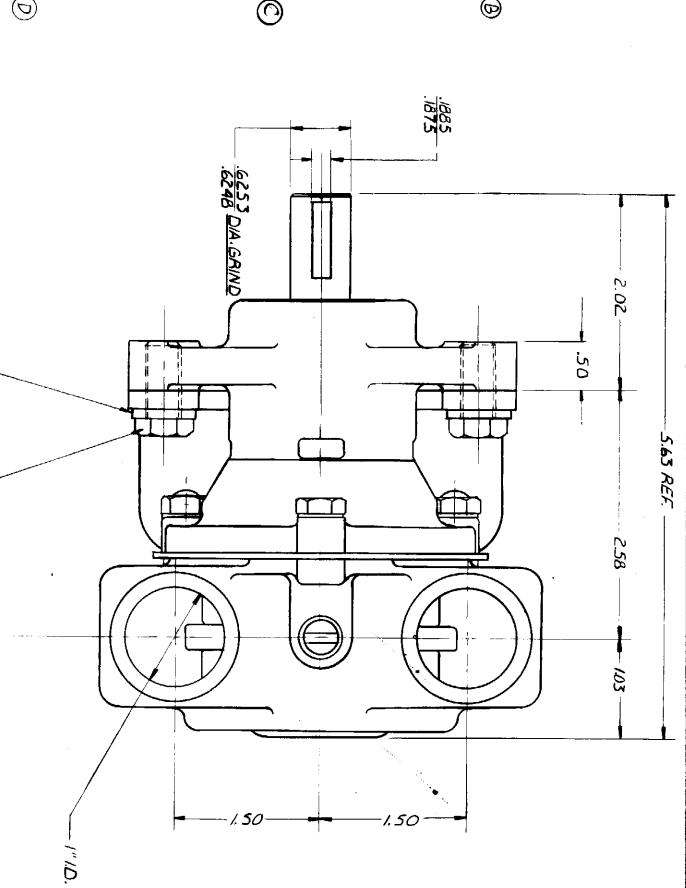
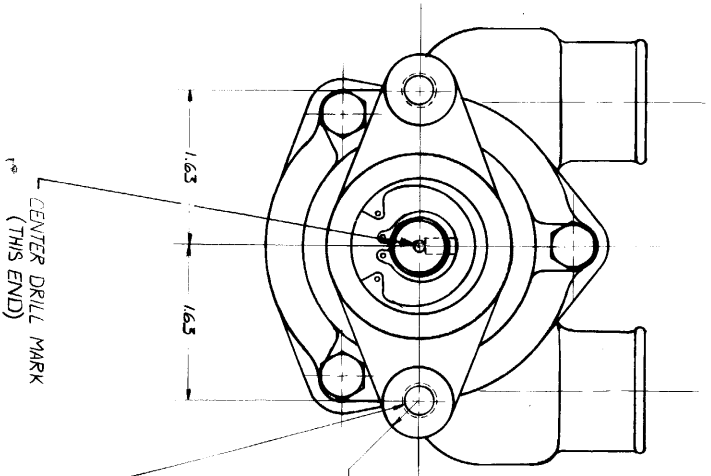

SERVICE ASSY NO.'S	COMPONENT ITEM NO.'S
SEAL & SEAT ASSY NO. 12859	6 & 7
MAJOR REPAIR KIT	NO. 12794
MINOR REPAIR KIT	NO. 12394

REV	DESCRIPTION	DATE	BY
E	12859 WAS 12322	5/1/79	SM
D	17644 WAS 17636	5/19/78	SM
C	12802 WAS 11904	5/1/78	SM
B	12314 WAS B388	5/1/78	SM
A	IDENTIFICATION STAMP ADDED		
REV	DESCRIPTION		

FLOW CURVE: 71035R-71036R

UNLESS OTHERWISE SPECIFIED TOLERANCE TO BE

CAST DIMENSION ± .020
MACHINED DIMENSION ± .010
FRACTIONAL ± .005
DECIMAL ± .005
ANGLES ± 1/2°

ALLOW 1/16 STOCK ON ALL FINISHED SURFACES FOR MACHINING
BREAK ALL SHARP EDGES TO MAX
CAST FILLERS AND RADII 1/16 R

SHERWOOD
A DIVISION OF HYDRO CORPORATION
500 E. WASHINGTON AVE. DETROIT, MICHIGAN 48226

DRAWN BY: R.A. DATE: 11/8-79
CHECKED BY: J.C. DATE: 11/5-79
APPROVED BY: J.C.

TITLE: PUMP ASSEMBLY - RUBBER IMPELLER

MATERIAL: SEE DETAILS

DWG NO: 64