



# ACU-TROL<sup>®</sup> CHEMICAL CONTROLLER FOR POOL AND SPA MODEL AK600



## INSTALLATION AND USER'S GUIDE



IMPORTANT SAFETY INSTRUCTIONS  
*READ AND FOLLOW ALL INSTRUCTIONS*  
SAVE THESE INSTRUCTIONS

# CONTENTS

<b>SECTION 1</b>	<b>4</b>	<b>SECTION 8 The Configuration Menu</b>	<b>48</b>
Information	4	General Setup Screen	48
<b>IMPORTANT WARNING &amp; SAFETY INSTRUCTIONS 4</b>		Global Alarm %	49
Controller Installation Configuration	6	Global Alarm Delay	49
Exploded View	6	Overfeed Clear Times	50
Parts List	7	Module 1, 2, or 3 Name	50
Controller CHEMICAL CONTROLLER OVERVIEW	8	Backlight Time	50
<b>TECHNICAL SUPPORT</b>		DFL1 Backlight	51
The Importance of Water Maintenance	9	Data Setup	51
<b>SECTION 2 Installation</b>	<b>10</b>	Time Spacing	51
Installation Preparation	10	% Used	52
Installation Overview	13	Number of Days	52
Mounting the Controller	14	Data Line	52
Plumbing Installation	15	Relay On Times Index	52
Electrical Installation	16	Event Index	52
Input Voltage Selection	17	Graphing the Event Index	53
Controller Installation Configuration	18	Sensor Setup	54
Exploded View	18	The System Menu	55
Parts List	19	Time	55
Controller Inputs & Outputs	20	Date	55
Chemical Feed Pump Installation	20	Weekday	56
Solenoid Location	21	Units	56
Using An Existing Main Timer	21	Program Mode (Version D6 and Higher)	56
Erosion Feeder Location	21	HOA	56
Flow or Pressure Switch	21	Serial Number	56
<b>SECTION Hardware 22</b>		The System Menu Sub Menus	57
Modules	22	Hardware Configuration	57
Sensor Modules	22	Display	58
Communication Modules	23	Display Setup	59
Memory Module	23	Printer Setup	61
Relay Modules	24	Security	62
Remote RS485 Modules	2	Entering a Password	64
<b>SECTION AK1200 Flow Cell</b>	<b>26</b>	Entering a Password	64
AK1200 Flow Cell	26	Reset Menu	65
Flow Cell Assembly	27	<b>SECTION 9 Programming</b>	<b>68</b>
Flow Cell Mounting	27	MPS Modules	68
Inlet and Exit Lines	28	Select MPS to Configure	69
Sensors	28	Select New Configuration	70
<b>SECTION Sensors</b>	<b>29</b>	Modifying MPS Settings Screen	71
pH and ORP Sensors	30	The Wiz Button	71
pH and ORP Sensor Care	30	Alarm Configuration	72
Flow Sensors	31	Automatic Set Point Alarms	72
Pressure Sensors	31	Pager/Voice/Email Alarms	73
Finishing your Installation	31	Communication	74
<b>SECTION 6 Operations</b>	<b>32</b>	Voice Communication	76
Introduction	32	Voice Communication Menus	77
Navigating in the Controller	32	Voice Button	78
Selecting Items	33	Voice system Testing	79
Changing Item Values	33	PVE	79
The Alphanumeric Keyboard	34	Pager Testing	80
Initializing the Controller	35		
<b>SECTION 7 The System Menu</b>	<b>36</b>		
The Display Menu	37		
The Specific Display Screen	38		
The Data Display Screen	39		
Program the Data Recording Interval	41		
Summary Display Screen	42		
MPS Timers	44		
Information Screen	46		

# CONTENTS

<b>SECTION 11 Service</b>	<b>81</b>	<b>SECTION 13 Appendix</b>	<b>122</b>
Manual MPS Operation	82	ORP Calibration Curves	122
Calibration	84	ORP Chemical Standards	123
pH Calibration	84	Calculated PPM Calibration Curve	124
ORP Calibration	86	Programming Command List	125
ORP Calibration for Large Systems	88	Programming Command List	126
Calibrating Calculated PPM	89	Proportional Feed Gain	127
Calibrating Temperature	90	MPS Wizards	128
Calibrating Digital Flow	91	Program for Super Chlorination	128
Conductivity Setup	93	Program for Dechlorination	129
Entering a Cyanuric Acid Measurement	94	Program for Auto Fill	130
Entering an Alkalinity Measurement	94	Program for chemical Storage	
Entering a Total Dissolved Solids Measurement	95	Tank Auto Fill	130
Entering a Hardness Measurement	96	Program for pH	131
Global Disable	96	Program for PPM	132
Clear Overfeeds	97	Program for Temperature	132
Enter Password	98		
Troubleshooting	98		
<b>SECTION 12 Optional Features</b>	<b>99</b>		
AK Color Setup	99		
Overview	99		
Expansion Modules	99		
Overview	100		
AKColor Configuration	102		
AKColor Setup	103		
AKColor Diagnostic Screen	104		
AKColor Start Up	106		
Cleaning the Sensor	107		
Loading the AKColor Reagents	108		
Calibration	109		
Preparation for Non-Operation	109		
Troubleshooting	109		
PPM Reading is 0 or 9.99	109		
Internal Red LED is on Continuously	109		
The Clear Voltage is Reading > 4.0 Volts	110		
The Clear Voltage is Reading < 2.3 Volts	110		
DPD and Clear Voltage are the Same	110		
Chemicals Don't Last	110		
Inaccurate Readings	111		
Network - AK245	112		
AK245 Installation	112		
Setting an AK245 Address	114		
Output Signals	115		
0-25MA Signals	115		
4-25MA Signals	115		
0-5V Signals	115		
Reversing1	15		
Electrical Specifications	116		
Controller Network - AK245 Setup	116		
Resetting AK245 Setup	118		
Controller Viewing AK245 Sensors	119		
Finishing and Testing	120		
Troubleshooting	120		

## IMPORTANT WARNING AND SAFETY INSTRUCTIONS



**SERIOUS BODILY INJURY OR DEATH CAN RESULT IF THIS PRODUCT IS NOT INSTALLED AND USED CORRECTLY.**



**INSTALLERS, POOL OPERATORS AND POOL OWNERS MUST READ THESE WARNINGS AND ALL INSTRUCTIONS BEFORE USING THIS PRODUCT.**



Most states and local codes regulate the construction, installation, and operation of public pools and spas, and the construction of residential pools and spas. It is important to comply with these codes, many of which directly regulate the installation and use of this product. Consult your local building and health codes for more information.



**IMPORTANT NOTICE - Attention Installer:** This Installation and User's Guide ("Guide") contains important information about the installation, operation and safe use of this product. This Guide should be given to the owner and/or operator of this product.

**DO NOT INSTALL THE CHEMICAL CONTROLLER WHERE IT CAN BE READILY ACCESSIBLE TO THE PUBLIC.**



Before installing this product, read and follow all warning notices and instructions in this Guide. Failure to follow warnings and instructions can result in severe injury, death, or property damage. Call (800) 831-7133 for additional free copies of these instructions.



### **RISK OF ELECTRICAL SHOCK OR ELECTROCUTION:**

**BEFORE WORKING ON THE CHEMICAL CONTROLLER: Always disconnect power to the controller at the circuit breaker before servicing. Failure to do so could result in death or serious injury to service person, pool users or others due to electric shock.**

**BE SURE TO DISCONNECT ALL SUPPLY CONNECTIONS BEFORE SERVICING.**

This product must be installed by a licensed or certified electrician or a qualified pool professional in accordance with the National Electrical Code (NEC), NFPA 70 or the Canadian Electrical Code (CEC), CSA C22.2. All applicable local installation codes and ordinances must also be adhered to. Improper installation will create an electrical hazard which could result in death or serious injury to pool users, installers or others due to electrical shock, and may also cause damage to property.



**BEFORE USING YOUR POOL, SPA OR HOT TUB, CHECK THE pH AND SANITIZER LEVELS OF THE WATER.**



**Do not permit children to operate this equipment.**



When mixing acid with water, ALWAYS ADD ACID TO WATER. NEVER ADD WATER TO ACID. When adding any chemical to the pool/spa, be sure to follow the manufacturer's instructions thoroughly.



**DO NOT MIX SODIUM HYPOCHLORITE AND MURATIC ACID**



Risk of electrical shock. Connect the Chemical Controller to a ground-fault interrupter-circuit (GFCI). Contact a qualified electrician if you cannot verify that the receptacle is protected by a GFCI.



**DISABLING THE OVERFEED TIMERS USING THE "CLEAR OVERFEED LIMITS" OR FLOW SWITCH WILL VOID NSF CERTIFICATION.**

**IF "CLEAR OVERFEED LIMIT" SETTING IS SET TO 24 HOURS, DO NOT SET "FEED TIME" GREATER THAN 20 HOURS AS THIS WILL VOID NSF CERTIFICATION.**

## IMPORTANT WARNING AND SAFETY INSTRUCTIONS

**⚠ WARNING** **WARNING CHEMICAL BURN HAZARD:** Make sure all pumps are switched off at the main circuit breakers at the house before drilling into any pipes. Securely fasten all electrical, water and chemical lines. Locate chemical feed pumps and chemical storage tanks in a safe and secure area.

**⚠ WARNING** Strictly follow the acid manufacturers safety and handling protocols including hand, body and eye protection when transferring or handling acid. Safety precautions should be used when handling Muriatic acid to control pH water levels. Muriatic acid can cause serious body injury and damage pool equipment. Extra care must be taken when installing, maintaining and operating acid pump feed systems. Acid is dangerous to handle and should be properly contained, transported, poured, stored, and dispensed.

**⚠ WARNING** Check the pH and sanitizer levels of the water before use.

Periodically use an independent pH and Chlorine test kit to verify that pH and chlorine is at a safe level. If the pH and Oxidation Reduction Potential (ORP) or Flow Cell sensors are broken, depleted or dirty with oils, lotions, or other contaminants, they can report inaccurate results to the system causing incorrect water chemistry, which could harm people or equipment.

Check the IntelliChem main status display each day to ensure there are no Alarm messages. See “Troubleshooting” section for more information. installing, maintaining and operating acid pump feed systems. Acid is dangerous to handle and should be properly contained, transported, poured, stored, and dispensed.

### GENERAL WARNINGS AND SAFETY PRECATIONS

PLEASE READ THIS USER MANUAL completely before installing or operating the equipment. The Controller Pool and Spa Chemical Controller is a Class 1 product for protection against electric shock and a Type 1 product with regards to disconnection of the control circuits.

Be sure to observe the following safety precautions:

- Do not permit anyone untrained or under the age of 18 to use this product.
- Unit must be properly grounded.
- Front panel must be closed before power is applied.
- Always turn OFF main circuit breaker to unit and all equipment before servicing.
- Touching the controller’s internal parts could result in injury and or damage to the controller. In case of a malfunction, only a qualified technician should repair the controller.
- Risk of Electric Shock. Connect only to a grounding type receptacle protected by a ground-fault circuit interrupter (GFCI).
- Do not bury cord. Route cord to eliminate external damage.
- Be careful not to damage any of the insulation on wires or the power cord. Should the cord be damaged, return it to your dealer for a replacement. Continued use could result in fire or electric shock.
- To reduce the risk of electric shock, do not use an extension cord to connect unit to electric supply, provide a properly located GFCI.
- Never remove or install any cables on the circuit cards when power is applied, damage to the components may occur.

#### **⚠ WARNING** **CHEMICAL BURN HAZARD**

Make sure pumps are OFF before drilling into pipes.  
Securely fasten all electrical, water and chemical lines. Locate chemical feed pumps and chemical storage tanks in a safe and secure area.

#### **⚠ WARNING** **CHEMICAL HAZARD CONDITION**

**DO NOT TURN CHEMICAL FEED PUMPS ON WHEN BOTH FLOW CELL VALVES ARE CLOSED.**

# Controller Chemical Controller Installation Configuration

## Exploded View

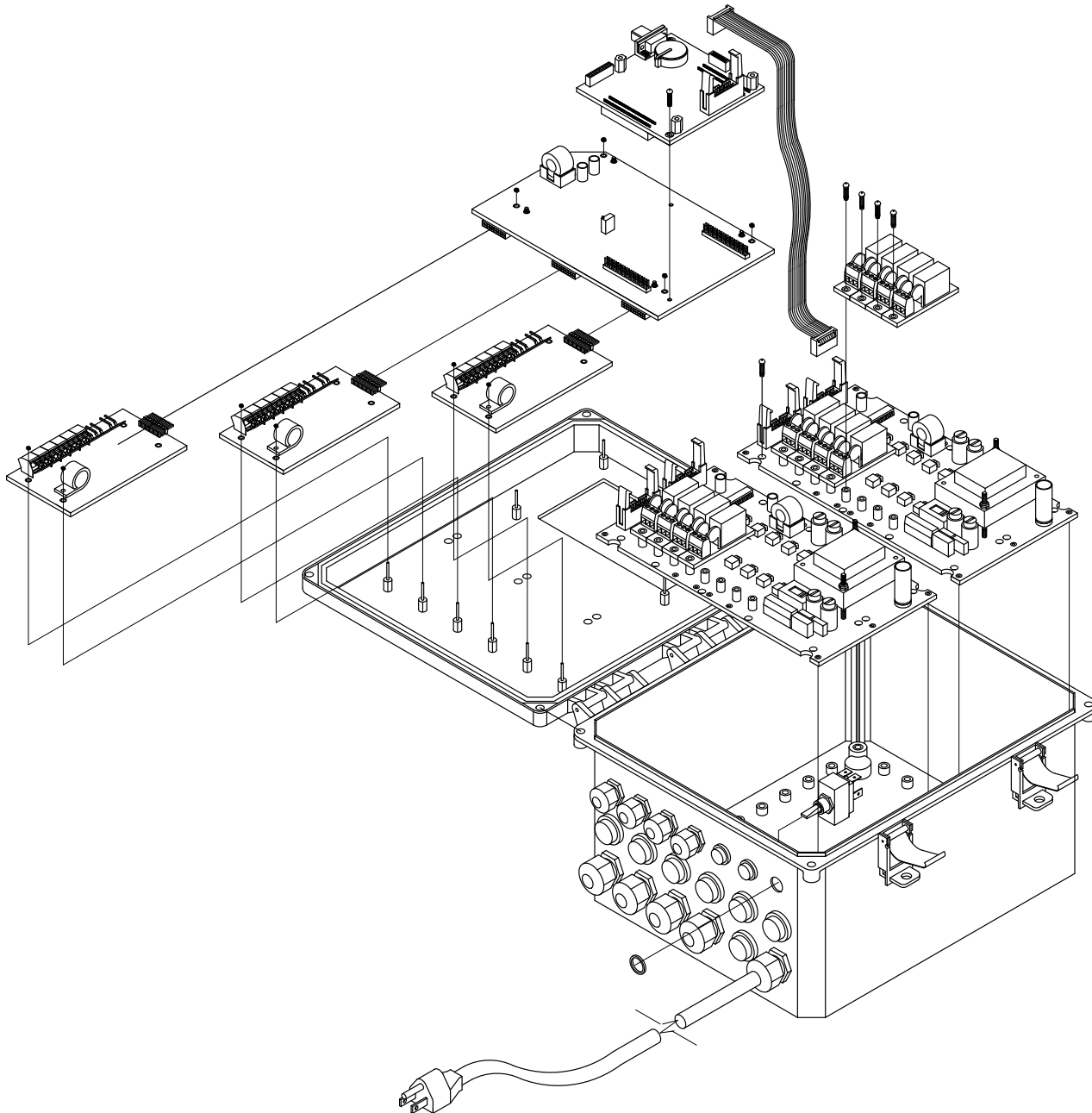

### WARNING

For 230 VAC Power the Controller Input Voltage Selection Switch **MUST** be changed from 115 VAC to 230 VAC or damage will occur to the Controller. This damage is **NOT** covered by the warranty. Do **NOT** connect any load not rated for the supply voltage to any of these relays.

## Parts List

DWG. #	PART #	DESCRIPTION
1		Enclosure, Controller, lid, overlay, and hardware
2	714000720	Kit, Controller, Power Switch
3	755000190	Cord, Power, Controller, GFCI ** Not permitted in all areas**
4	714000110	Strain Relief, 5/8", liquid tight
5	714000100	Strain Relif, 1/2", liquid tight
6	724000120	PCB, Relay Board, Controller, 4 NO
7	724000130	PCB, Sensor, pH, ORP, Temp, 3 switch
8	724000090	PCB, Motherboard, Controller
9	724000100	PCB, Interface Board, Controller
10	724000110	Display, Touchscreen, Controller
11		Ribbon Cable, Controller
12		Relay board mounting screws
13	724000050	Socket, Relay NO(110/24/Dry)
14	714000120	Kit, latch, Integra Enclosure

### Not Shown

725000020	Modem, Standard
735000010	Modem, Wireless
724000150	PCB, Sensor, Pressure, Temp
724000160	PCB, Sensor, pH, ORP, Cond, Temp
724000180	PCB, Sensor, pH, ORP, Color, Temp
724000190	PCB, Sensor, pH, ORP, Color, Cond, Temp.
724000060	Socket, Relay, NC (110/24/Dry)

### ORP and pH Sensor Replacement Part Numbers

<b>ORP SENSOR</b>	<b>P/N 744000340</b>
<b>PH SENSOR</b>	<b>P/N 744000260</b>

## Controller CHEMICAL CONTROLLER OVERVIEW

Acu-Trol®<sup>®</sup>, a technological leader in swimming pool automation, congratulates you on your selection of the Controller Chemical Controller ("Controller") swimming pool controller. The Controller will maintain the pH and sanitizer levels, maintain a set temperature, and control up to 16 external devices in a pump room, on up to three pools or spas. The Controller is specifically designed to be easy to use and install while meeting the needs of the most demanding applications.

### *The Controller Chemical Controller features:*

**MODULAR DESIGN:** The Controller is designed to grow with your needs. Increase the number of bodies of water, add true PPM control, conductivity control, or add additional relays to automate your pump room. The Controller can be easily modified at the installation site with only a few basic tools.

**INTERFACE:** The Controller uses a touch screen display panel with a built in graphical user interface for simple operation. A full alphanumeric keyboard is available for easy calibration and programming. An automatic backlight ensures clear visibility of the touch panel, and conserves power by turning on only when the touch screen is in use.

**MEMORY:** The Controller has built-in memory that automatically saves your programming. If your controller ever loses power, it will retain all programmed values.

**DATA RECORDING:** The Controller has the ability to record data from all sensors and to store up to 6505 measurement lines, the equivalent of 271 days of hourly recordings.

**CALCULATED READINGS:** The Controller calculates and displays the free available chlorine, scaling index values for each body of water, and two (2) differential readings based on the four (4) pressure sensors.

**RELAYS:** The ability to control up to 16 relay modules enables the Controller to automate nearly every device in your pump room. There are various types of relay module configurations available to meet most load requirements.

**DETAILED DISPLAY:** In addition to the chemical readings, the Controller will display important information about the relays controlling each device. It will tell your operator whether each relay is currently on or off, how long each relay has been on, and any relays that have reached their programmed time limits and are now in alarm.

**SENSORS:** The Controller can interpret readings from many types of sensors, allowing you to measure pH, ORP, true PPM, Temperature, pressure, and conductivity. Each sensor has its own unique circuitry, isolating it for more exact measurements.

**VOLTAGE:** The Controller can be configured to use either 115 VAC or 230 VAC. This allows the controller to be plugged in to an existing outlet, or wired directly in to the electrical system.



The Controller Installation, Operation and Programming Guide explains the procedures for proper installation and operation. Section one (1) the installation guide, consists of Sections 2, 3, 4, and 5, and introduces the parts of the controller and the process to follow when installing the electrical and plumbing portions. Section two (2) the operation guide, consists of Section 6, and describes all the available screens and menus of the controller, from navigating and initializing the screens to programming and customizing specifications. Section three (3) the programming guide, consists of Sections 7, 8, 9, 10, 11, and 12, and describes troubleshooting strategies, optional devices that may be added to your Controller, and many of the relevant charts and diagrams..

### **Technical Support**

**Phone: (800) 831-7133 - Fax: (800) 284-4151  
visit [www.pentairpool.com](http://www.pentairpool.com) and [www.staritepool.com](http://www.staritepool.com):**

## **The Importance of Water Maintenance**

A chemical controller is designed to maintain specific levels of disinfecting and balancing chemicals. Disinfecting chemicals help to control the growth of bacteria and other organisms in the water of a pool or spa. Balancing chemicals keeps a pool or spa at a certain pH level, preventing the water from becoming acidic, and corroding the pool and its equipment, or becoming basic, and causing buildup on the equipment.

Water maintenance is an important part of operating a pool and spa. Pool operators should be trained in water maintenance by an authority recommended by their local health department. Water maintenance requirements are generally determined by the county or state and can vary widely. However, most requirements fall within the following range recommended by the National Swimming Pool Foundation:

**Filtration:** Minimum turnover rate of six hours for a pool and 30 minutes for a spa.

**Water Balance:** – pH 7.2 – 7.6, alkalinity 80-120 PPM.

**Oxidation Reduction Potential (ORP)** – A reading of 650 mV - 750 mV.

**Total Dissolved Solids** - Should not exceed 2000 PPM.  
(excluding pools using a salt chlorine generator)

This information is meant to provide pool operators with a basic idea of the range of water maintenance requirements, and the importance of water maintenance. To ensure that your facility is in compliance with all local regulations please check with your local health department.

## Section 2 Installation

### Installation Preparation

As soon as your controller is delivered, inspect the shipping carton carefully for damage. Report any damage directly to the shipping company. Compare the packing list to the contents of the carton. If anything is missing contact your local Acu-Trol dealer. Use care when unpacking equipment to avoid damage or loss of small parts.

We strongly recommend that you plan out the pool room layout before you install the Controller Chemical Controller. Figure 1 is a sample of a pool room layout. Your layout will vary depending on your equipment, the size of your room, etc. It is important to mark and plan all electrical and plumbing connections before making changes to the existing system.

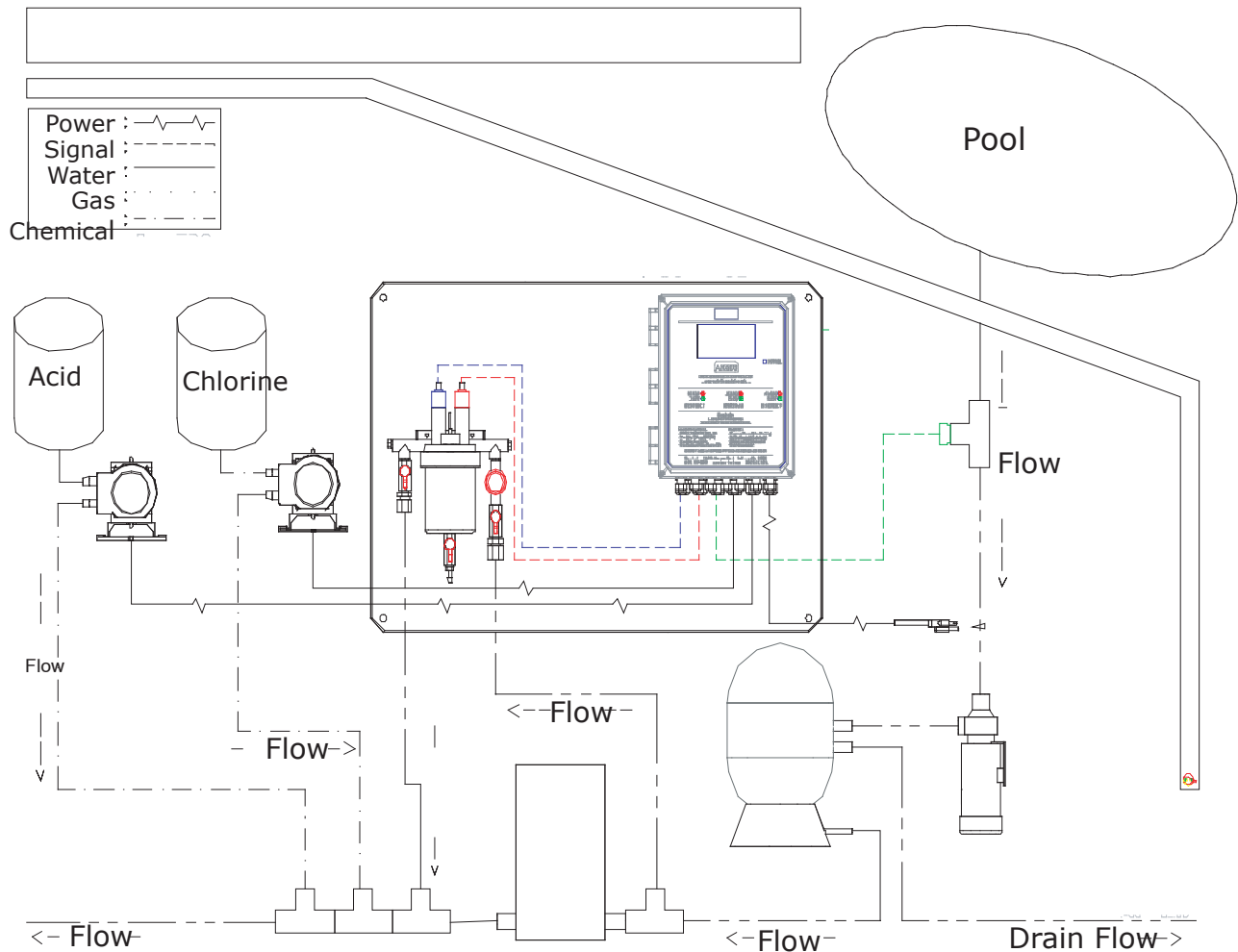

Figure 1. Controller Chemical Controller System

The modular design of the Controller allows the connection and control of any device to any relay. Determine which device you want to connect to each relay or input before you begin the installation process. For Controller can control multiple bodies of water. It is helpful if the configuration for each body of water is the same: i.e. your pH pump is always connected to relay 1.

Below are Relay and Input Mapping Tables to help in the planning and organization of new installations. Use these tables to record your input and relay configurations. This information will be valuable when the system has an alarm, or when you choose to upgrade the system to control an additional body of water.

### Example Input Table

INPUT NAME	SYSTEM NAME	INPUT USED FOR
PH1	Kids Pool	Flow cell measurement for acid feed control
ORP1	Kids Pool	Flow cell measurement for Cl feed control
Temp1	Kids Pool	Flow cell measurement for heater control
FL1	Kids Pool	Flow cell magnet indicates flow

### Example Relay Table

RELAY	SYSTEM NAME	RELAY USED FOR	VOLTAGE
1	Kids Pool	Acid Feed Pump	115VAC
2	Kids Pool	Erosion Feeder Solenoid	24VAC
3	Kids Pool		
4	Kids Pool	Heater Control	Dry

To simplify the installation process, Acu-Trol manufactures the Controller with default factory relay and input configurations. The factory default settings are stored in the controller and can be reloaded at any time.

Site Name \_\_\_\_\_

**Input Mapping Table**

INPUT NAME	SYSTEM NAME	INPUT USED FOR

**Relay Mapping Table**

RELAY	SYSTEM NAME	RELAY USED FOR	VOLTAGE
1			
2			
3			
4			
5			
6			
7			
8			
9			
10			
11			
12			
13			
14			
15			
16			

**VOLTAGE:** In most cases, the devices attached to the controller will use the same voltage as the Controller. A controller configured to use 115 VAC will not be able to run devices requiring 230 VAC, and vice versa. The Controller relay modules will switch the module's voltage to the load to turn it ON and disconnect the voltage from the load to turn it OFF.

## Installation Overview

The following steps are required to completely install an Controller Chemical Controller:

1. Identify new and existing equipment to be connected.
2. Decide if the sensors will be in-line, in a separate by-pass line, or if the AK1200 flow cell will be used.

**CAUTION**

**If the AK1200 is used, the input water maximum pressure is 25 PSI.**

3. Determine the supply voltage, 115 VAC or 230 VAC, and set the supply voltage switch as necessary.
4. Determine if the control to the equipment uses the same voltage as the supply voltage. All controlled equipment must be compatible.
5. Determine the plumbing locations for the flow cell bypass inlet and outlet.
6. Mount the Controller away from direct sunlight and on a flat vertical surface.
7. Connect the supply voltage with main breaker off (Must be a separate dedicated circuit GFCI).
8. If using an AK1200 flow cell install the bypass now.
9. Connect the sensors.
10. Test the plumbing for leaks.
11. Turn on/plug in the Controller for the first time.
12. Test the equipment, using the Controller manual relay mode.
13. Calibrate the probes, then recalibrate as the probes acclimate to the water. Acclimation can take as little as two hours or as long as 24 hours.
14. Program the Controller.
15. Call or visit the controller over the next few days to insure the system is balanced and in control. Fine-tune the setup if necessary.

## Mounting the Controller Chemical Controller

Select a location for mounting the Controller that will meet the following conditions:

- At least ten (10) feet from open water.

### WARNING

**Proper and safe operation requires an earth ground connection.**

- Supply power must be routed to the Controller in accordance with the applicable codes in the area; the supplied cord is not code in some areas. Please have a licensed electrician perform any and all electrical.
- The installation surface must be solid and vertical. Do not mount the controller in a horizontal position.

### WARNING

**Keep the Controller out of direct sunlight and inside a room if possible, a shade screen should be used for outdoor installations.**

- Maintain adequate clearance for opening the enclosure door.
- The environment should be free of chemical fumes and excessive heat. Do not install the Controller in areas that exceed 110° Fahrenheit.
- Mount the controller as far as possible from potential sources of electrical interference. To mount the Controller to your chosen surface:

- Attach the four (4) mounting brackets to the back of the controller, using the supplied hardware.

- Hold the controller against the mounting surface with the lid closed and mark the four (4) holes located in the top and bottom brackets connected to the controller.

- Prepare holes as necessary and secure controller.

- Make sure the controller box is not

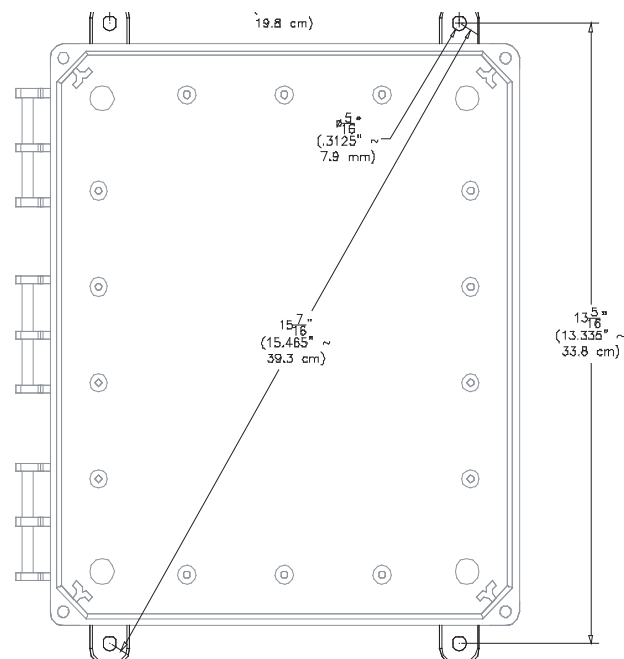

## 2.4 Plumbing Installation

Every Controller Chemical Controller installation will be different depending on the type of equipment you have, the plumbing that already exists, and the amount of available room for the installation. It is strongly suggested that you create an installation plan for the plumbing and the controller. This section gives the basic principles to be applied for any specific installation, which are listed as follows:

- Turn OFF all equipment.
- Determine a suitable location for the AK1200 Flow Cell. (See flow cell manual for detailed setup instructions).
- Securely mount the AK1200.
- Locate where the water will be supplied from and returned to each AK1200.
- Install the supply and return lines for each AK1200.
- Locate the chemical injection points.
- Prepare and install the chemical injectors.
- Install the chemical storage containers.
- Install the sensors.
- Turn on the main circulation pump.
- Check for leaks.
- Verify flow switch magnet in AK1200 is being pushed up with the flow.
- Verify the AK1200 is not under any vacuum by opening the bottom sample valve. A stream of water should be released. If no water is released, and you see bubbling around the sample port, close the AK1200 outlet valve until the bubbling stops and a stream of water is released from the sample port.
- Leave the 1200 flow cell full of water to allow sensors to begin acclimating to system water.
- Call or visit several times over the next few days to verify system integrity

### WARNING

**To ensure that your installation complies with all local codes have a licensed plumber complete all plumbing installations.**

## Electrical Installation

Each electrical installation for the Controller Chemical Controller is different depending on the electrical codes in your local area, the types of devices you want the Controller to control, and the existing wiring in your facility. While we are unable to provide you with specific advice regarding your installation, we do suggest that you follow these basic steps.

- Identify the new and existing equipment to be connected.
- Determine the supply voltage, 115 VAC or 230 VAC and if an external ON/OFF switch is necessary.
- Determine if the equipment control voltage and supply voltage are the same.
- Connect the supply voltage. (Must be on a separate dedicated GFCI circuit)
- Connect each load to the corresponding relay.
- Connect the sensors. Route the sensor wires through the three small strain reliefs' into the controller and install them in to the appropriate connectors in the sensor module.
- The polarity (+ and -) of the pH and ORP sensors must be observed.
- The ORP sensor (+) is marked ORP+
- The pH sensor (+) is marked pH+
- The green leads are (-) polarity.
- Do not cut the sensor wires.
- After the wiring is complete, close the panel and tighten the strain reliefs'. Wrap and tie any excess wire into a coil.
- Do not stuff excess wire inside the controller.
- Test the equipment, using the Controller manual relay mode.



### CAUTION

**To ensure compliance with all state and local codes, have a licensed electrician perform any and all electrical work.**



## Input Voltage Selection

The Controller Chemical Controller operates on input voltages of 115 VAC or 230 VAC. The factory default input voltage is set for 115 VAC. The supply power is most commonly used to power the feed pumps and other external loads. If all the loads are 115 VAC then use 115 VAC and if all the loads are 230 VAC then use 230 VAC as the input voltage. It is also possible to have one relay board powered with 115 VAC and another relay board with 230 VAC. This is beneficial when there is a mix of load voltages. If you need to have your relay boards use different input voltages please contact your local Acu-Trol dealer for further instructions and assistance.

### WARNING

**If the Controller Chemical Controller is connected to 230 VAC the voltage switch on the relay board must be changed to 230 VAC.**

### Electrical Limits for the Controller Chemical Controller

ITEM	DESCRIPTION	LIMIT
Input Voltage	Maximum Input AC Voltage	250 VAC
Input Current	Maximum Current for All Relays	10 Amps VAC per relay board
Input Current	Maximum Current for Single Relays	5 Amps VAC
Temperature	Minimum/Maximum Operating Temp	30-110 °F
Standby Current	Current with all relays OFF, LED ON	90 mA (AC) Typical
	Current with all relays OFF, LED OFF	65 mA (AC) Typical
Sensor Range	pH	4.2-9.8 pH units
	ORP	0-999 mV
	Temp	32 – 212°F
	AKColor PPM	0 – 8 PPM

# Controller Chemical Controller Installation Configuration

## Illustrated Parts View

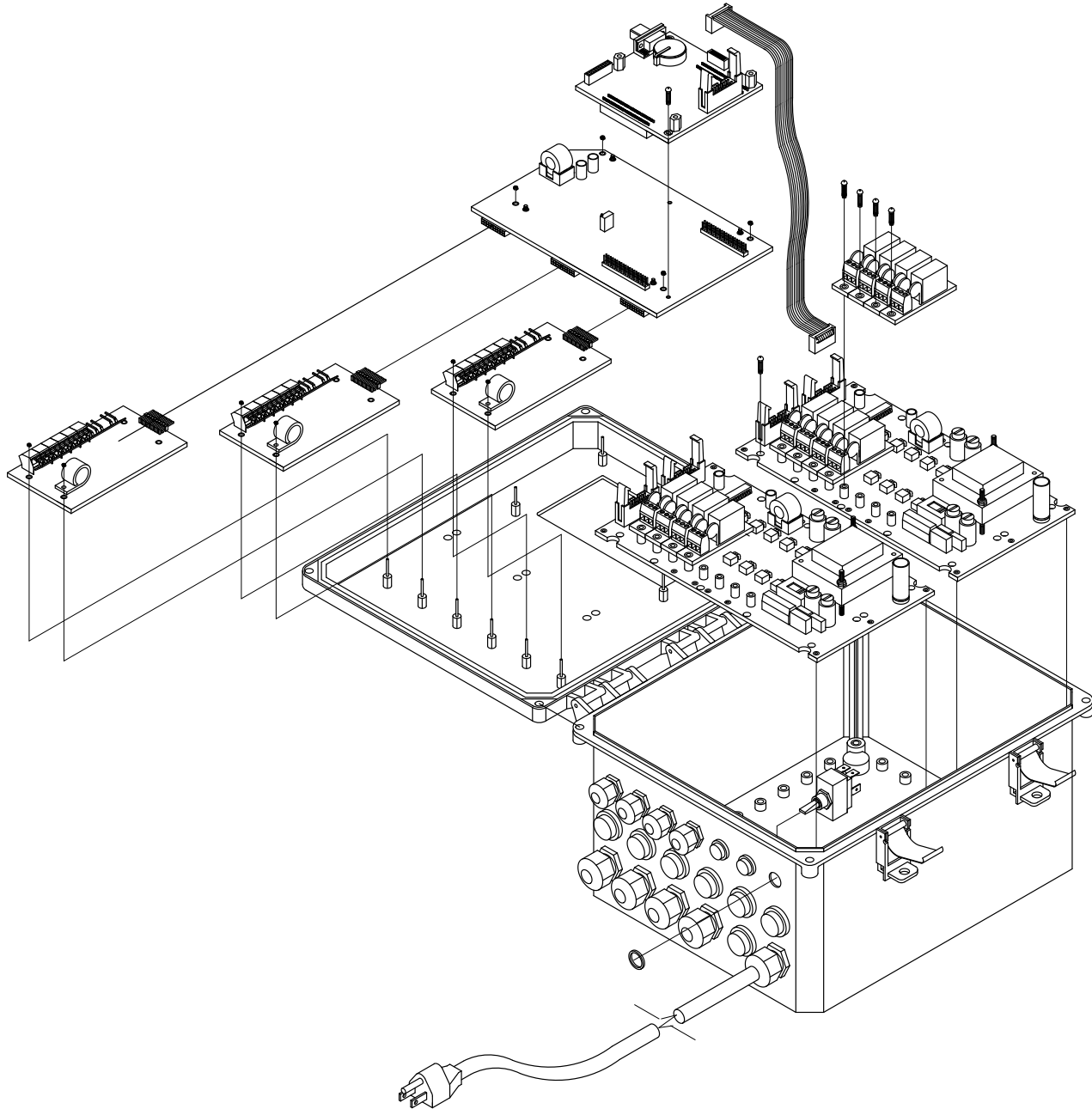

### WARNING

For 230 VAC Power the Controller Input Voltage Selection Switch **MUST** be changed from 115 VAC to 230 VAC or damage will occur to the Controller. This damage is **NOT** covered by the warranty. Do **NOT** connect any load not rated for the supply voltage to any of these relays.

---

**Parts List**

DWG. #	PART #	DESCRIPTION
1		Enclosure, Controller, lid, overlay, and hardware
2	714000720	Kit, Controller, Power Switch
3	755000190	Cord, Power, Controller, GFCI ** Not permitted in all areas**
4	714000110	Strain Relief, 5/8", liquid tight
5	714000100	Strain Relif, 1/2", liquid tight
6	724000120	PCB, Relay Board, Controller, 4 NO
7	724000130	PCB, Sensor, pH, ORP, Temp, 3 switch
8	724000090	PCB, Motherboard, Controller
9	724000100	PCB, Interface Board, Controller
10	724000110	Display, Touchscreen, Controller
11		Ribbon Cable, Controller
12		Relay board mounting screws
13	724000050	Socket, Relay NO(110/24/Dry)
14	714000120	Kit, latch, Integra Enclosure

**Not Shown**

725000020	Modem, Standard
735000010	Modem, Wireless
724000150	PCB, Sensor, Pressure, Temp
724000160	PCB, Sensor, pH, ORP, Cond, Temp
724000180	PCB, Sensor, pH, ORP, Color, Temp
724000190	PCB, Sensor, pH, ORP, Color, Cond, Temp.
724000060	Socket, Relay, NC (110/24/Dry)

## Controller Chemical Controller Inputs & Outputs

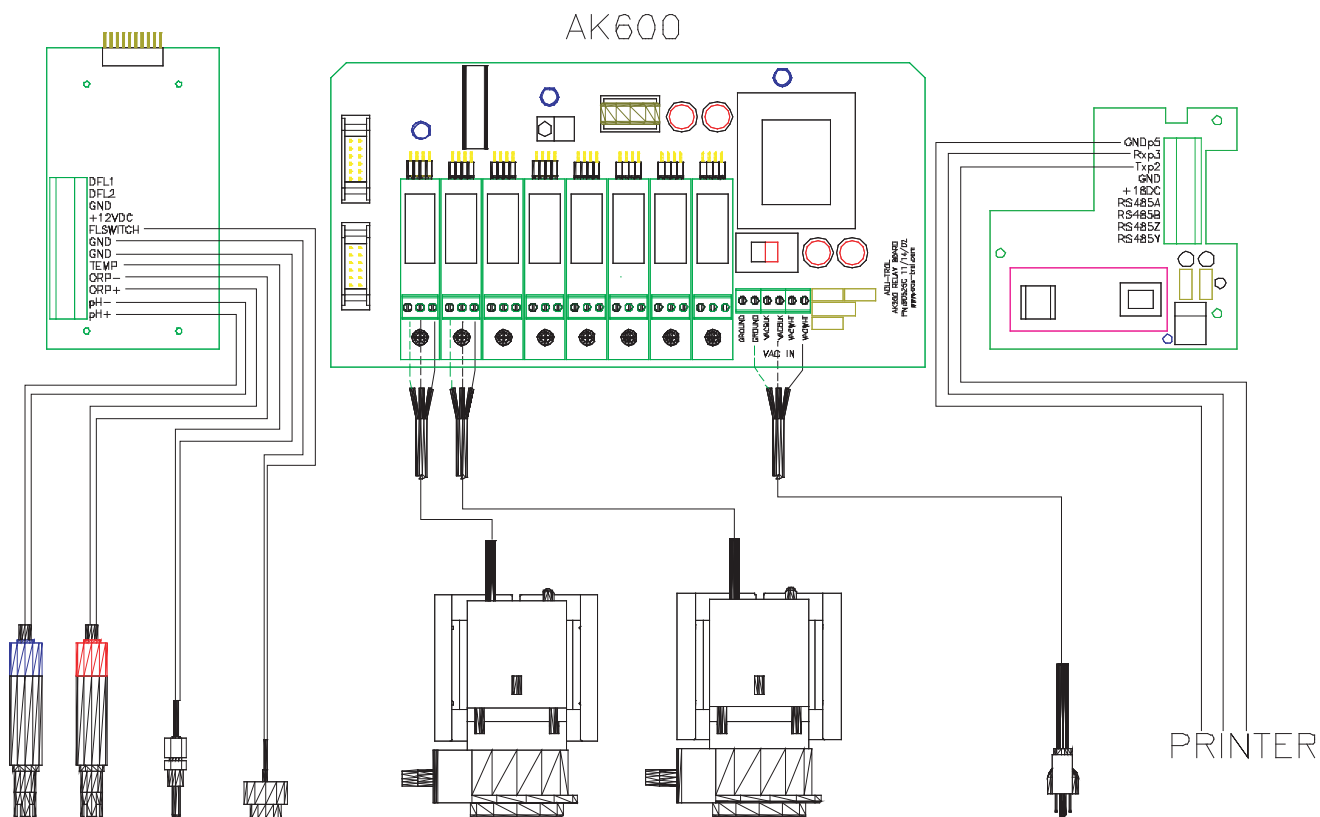

## Chemical Feed Pump Installation

Follow the instructions included with the chemical feed pump for installation if it is not already installed. Follow the list below for location recommendations:

- Mount at least 10 feet from open water.
- Close enough to the Controller for the feed pump power cords to reach.
- Remove the electric plugs from the feed pumps and strip the ends.
- Route the power cords to the Controller through the lower fittings and attach to the appropriate relay terminals on the appropriate relay module boards.
- Conduit or external plugs can also be used (according to the codes in the local area).
- When installing metal conduit into the controller, a ground LUG should be used to connect the conduit to the relay board ground.

## Solenoid Location

For a sanitizer erosion feeder a solenoid valve will be required to control the flow through the feeder. The solenoid should be installed on the inlet side of the feeder to minimize chemical contact with the internal parts of the solenoid, unless otherwise specified by the feeder manufacturer. The solenoid may have an inlet side and an outlet side; make sure the direction is correct. Special fittings for the solenoid may need to be obtained.

The control relay can supply a variety of voltages depending on the relay module installed (115, 230, 24 VAC or switch only). In order to support a 230 solenoid, a 230 supply voltage must be provided.

## Erosion Feeder Location

To install a sanitizer erosion feeder follow the instructions included with the feeder for installation if it is not already installed.

## Flow or Pressure Switch

It is highly recommended that a flow or pressure switch be used to prevent the Controller from feeding chemicals if the main pump is OFF. Any flow switch used in this manner should be closed when flow is present and open when flow is absent.

The AK1200 flow cell has a built in flow switch that protects against feeding chemicals in a NO flow condition.

### WARNING

**When using anything other than Acu-Trol switch devices the flow switch must not supply any voltage to any switch inputs or damage to the controller may occur.**

## Using An Existing Main Timer

After the Controller has been mounted cut the plug off the end of the supplied cord and strip the wires. Route the wires to the timer box and use an electrical strain relief connector to fasten the power cord to the box at the entry point. When using 115 VAC, connect the hot and neutral to the corresponding hot and neutral on the switched side in the timer box. For 230 VAC connect the white and black wires to the two hot wires in the timer box. For 230 VAC the Controller will use both wires as hot for two (2) phase 230 VAC or one wire as hot for single phase 230 VAC.

### CAUTION

**Only use proper wires and conduits for these conditions in accordance with all local codes and regulations.**

## Section 3 Hardware

### Modules

Modules are the electronic controls and components that make up the Controller. Each module has a specific function or functions that tell the controller what information to accept, and what information to display. The modular design of the Controller enables it to interface with many types of modules including Sensor, Communication, Relay, Memory and Remote.

#### Sensor Modules

Sensor modules determine the types of sensors that the controller can receive signals from. There are six available sensor modules for the Controller. They are:

- AK610: pH, ORP and Temperature control, calculated PPM can also displayed.
- AK612: Pressure control, Temperature, 5 Switch inputs.
- AK613: pH, ORP, Temperature, and Conductivity/TDS control
- AK615: pH, ORP, Temperature and Colorimetric PPM control
- AK616: pH, ORP, Temperature, Colorimetric PPM and Conductivity/TDS control.
- AK617: Pressure, Temperature, 5 Switch inputs and Backwash Stager Control

The following table lists the sensor modules with the sensors they interface with. The sensor number indicates how many sensors are included with the module; \* indicates the sensors not included with the sensor module.

Module	pH	ORP	Colorimetric	Conductivity	Temperature	Flow Switch	Pressure	Flow Rate	Backwash Stager
AK610	1	1			1	1		2*	
AK612					1	5	4		
AK613	1	1		1	1	1		2*	
AK615	1	1	1		1	1		1*	
AK616	1	1	1	1	1	1		1*	
AK617					1	5	4*		2

## Communication Modules

The Controller has the ability to work with several types of communication modules. The controller can communicate with a PC through an RS232 cable, a standard modem, or a wireless modem. The Controller can also communicate directly with a serial printer, and certain remote modules. Most of the communication modules can be installed simultaneously; however the corresponding hardware will only allow one communication device to function at a time.

AK620: High-speed voice modem. This modem has only the modem connector, and no other connectors

AK621: A high speed voice modem with the addition of two more com-ports. These additional comports include an additional serial RS232 interface for printers and an RS485 for remote module connections.

AK622: Two additional communication ports. These additional com-ports include an additional serial RS232 interface for printers and an RS485 for remote module connections. No modem is included in this communication module.

Wireless Modem: The wireless modem allows the controller to be accessed over the internet from any PC. Wireless modems are a perfect solution for installations without phone lines. Please note that the wireless modem and the standard modem can not be installed in the same controller.

## Memory Module

The memory module expands the data recording capabilities of the Controller and enables the controller to be accessed from any touch tone telephone.

The Controller memory module expands the size of the data log in the controller. It enables the controller to record each time one of the 16 available relays turns on or off, and the corresponding time and date. The memory module will hold up to 4500 lines of relay state change data.

The Controller Voice module is included in the memory module. The memory module is required for voice operation of the Controller. The voice module enables communication with the controller from any standard touch tone telephone. This module allows the operator to hear the chemical readings and relay on and off times over the phone. He or she can then make any necessary adjustments to the controller's programming using a simple menu.

Note: For more information on the operation of memory, communication, or sensor modules please refer to the PROGRAMMING GUIDE.

### WARNING

**Removing the memory chip from the board will erase all the data stored on the memory module.**

## Relay Modules

The AK 600 is able to automate nearly any device in your pump room. The controller uses a relay module to turn electricity to the device on and off. Each Controller can control up to 16 relay modules. Each relay module can control one device. All relay modules must be installed in a relay board. A relay board can hold 8 relay modules. An Controller can hold two relay boards. Relay boards can be installed at the factory, or added later in the field.

Relay modules are available in seven different models. The type of relay module used depends on the load requirements of the device you wish to control with the relay module. To determine the load requirements, please consult the instruction manual or the device manufacturer. Any combination of the seven models of relay modules can be installed in the eight available slots on a relay board, so long as the combination does not exceed the combined maximum current for the relay board. The combined maximum current for any individual relay board is 10 amps. The combined maximum current for two relay boards is 20 amps. The maximum relay current for the relay board is 5 amps when switching 115 VAC and .5 amps when switching 24 VAC.

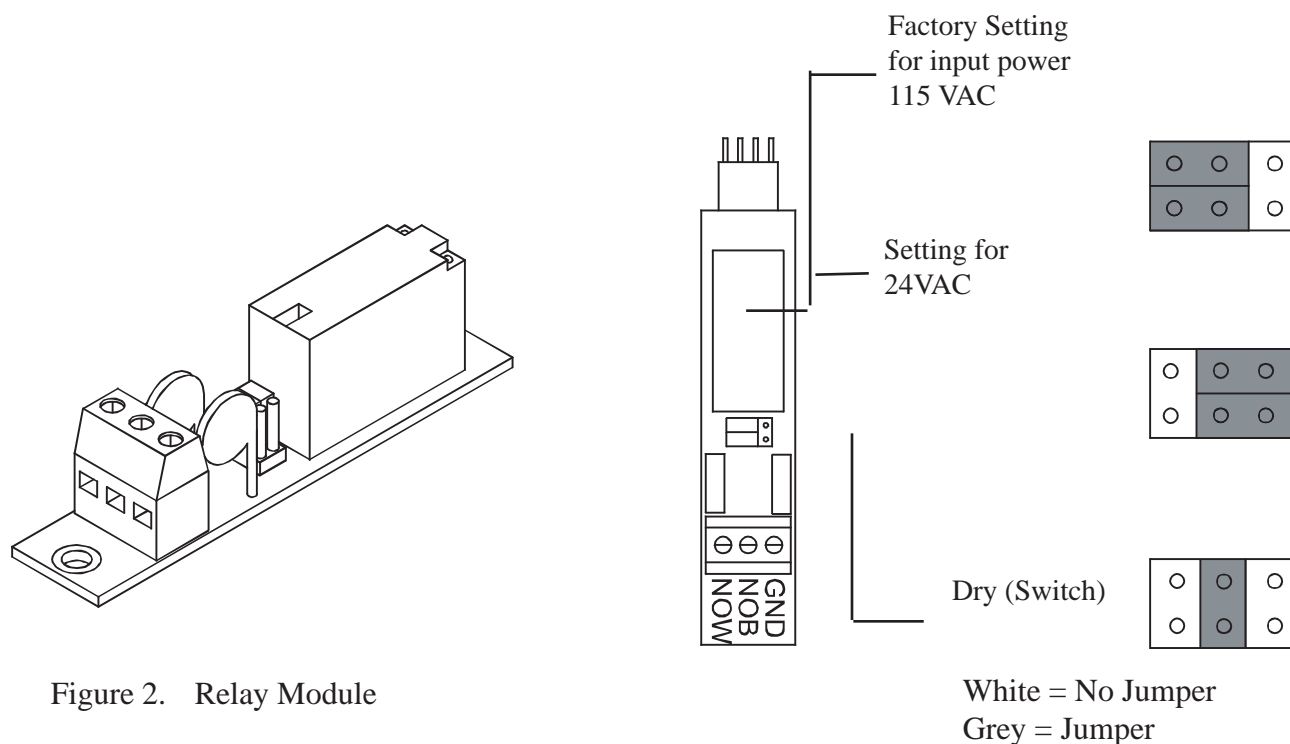

- **DRY CONTACTS:** These relays act as a dry contact switch only and have no connection to the input VAC. The relay ratings are 5A and 250 VAC
- **115 VAC Normally Closed:** These relays supply the input voltage to the load when the relay is in the "OFF" mode. Note that both VAC inputs are controlled by the relay. The relay ratings are 5A and 250 VAC.
- **115 VAC Normally Open:** These relays supply the input voltage to the load when the relay is in the "ON" mode. Note that both VAC inputs are controlled by the relay. The relay ratings are 5A and 250 VAC.



- **115 VAC SPDT:** These relays are hardwired selectable to be either NO (Normally Open) or NC (Normally Closed) switching of the input voltage. They are always powered, and the wiring will dictate whether the power flows in the on or off position. The relay ratings are 5A and 250 VAC. The neutral is common for both NO and NC.
- **24 VAC Normally Closed:** These relays supply 24 VAC to the load when the relay is in the "OFF" mode. Note that both VAC inputs are controlled by the relay. The relay ratings are 5A and 250 VAC.
- **24 VAC Normally Open:** These relays supply 24 VAC to the load when the relay is in the "ON" mode. Note that both VAC inputs are controlled by the relay. The relay ratings are 5A and 250 VAC.
- **24 VAC SPDT:** These relays are hardwired selectable to be either NO (Normally Open) or NC (Normally Closed) switching of the 24 VAC. They are always powered, and the wiring will dictate whether the power flows in the on or off position. The relay ratings are 5A and 250 VAC. The neutral is common for both NO and NC.

## Remote RS485 Modules

The remote modules are connected to the Controller using RS485 serial communication and require the appropriate communication module. These modules can be located up to 4000 feet from the Controller. The present modules are as follows:

**AK245 Quad Output:** This module has four (4) isolated outputs of which each can be configured for 0-5VDC, 0-25mA, or 4-20mA: Each output on this module is isolated and the 4-20mA includes power. These outputs can be used for variable loads and for remote monitoring equipment, including chart recorders, pumps, and valves.

**AK250 Quad Input:** This module has four (4) isolated inputs of which each can be configured for 0-5VDC or 4-20mA input. These inputs can be used for sensors and controls. There are also four (4) switch inputs for general switch operations.

## SECTION 4 AK1200 Flow Cell

### 4.1 AK1200 Flow Cell

Remove flow cell from shipping carton and make sure all parts are included with AK1200 flow cell.

- 1 – AK1200 Lid
- 1 – Flow switch magnet
- 1 -Sample barb fitting
- 1 - Filter assembly w/ O-Ring
- 1 - Flow switch w/ O-Ring, 2' and 10' wire lengths available.
- 2 - Mounting screws
- 1 – AK1200 Jar with O-Ring
- 3 - ¼" Valves.
- 4 - ¼" NPT by ½" flex fittings.
- 2 - ¼" plugs.
- 1 - ¼" Close Nipple
- 1 - Thread Sealing Tape
- 1 – Pressure gauge\*

Note that ½" flexible tubing is not included and must be supplied by the installer.

\* Use of Pressure Gauge is Optional

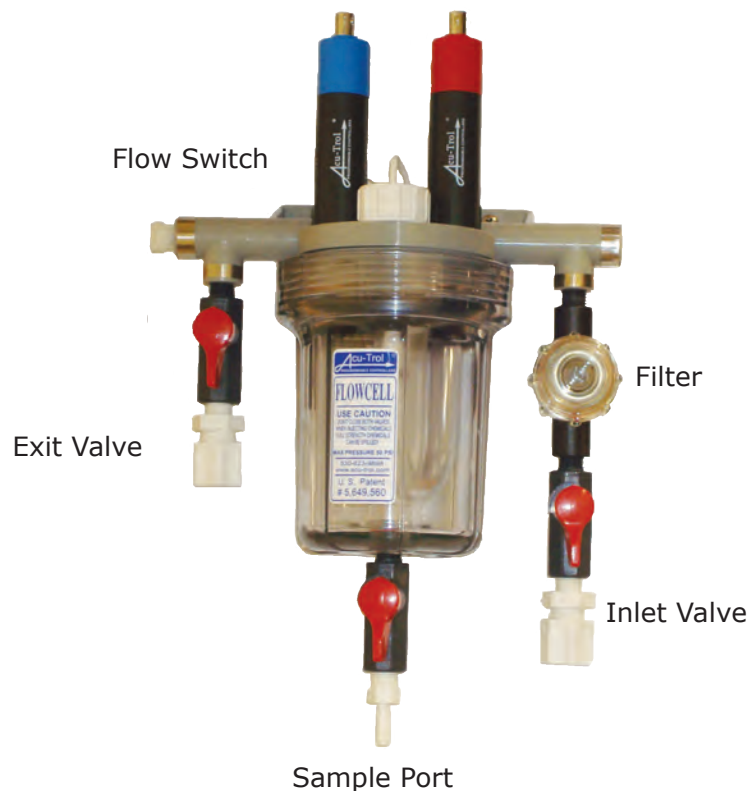

## Flow Cell Assembly

### WARNING

DO NOT OVER TIGHTEN FITTINGS ON GRAY FLOW CELL TOP AS THIS MAY BREAK OR CRACK FLOW CELL TOP.

1. Wrap all four flex fittings with thread seal tape. Install two flex fittings into two ball valves.
2. Wrap barb fitting with thread seal tape. Install barb into remaining ball valve.
3. Wrap both ends of the close-nipple with thread seal tape. Install into the filter assembly using (either end OK). Hand-tighten only.
4. Install one ball valve into the filter.
5. Install the filter and remaining ball valves as shown in the figure.
6. Verify that the flow switch magnet is in the flow cell tube with the large, or hat end pointing down.

**NOTE: Wrap fittings only twice around with thread seal tape.**

### Flow Cell Mounting

1. Select a suitable location for the flow cell meeting the following recommendations:
2. The flow cell location should be within ten (10) feet of the controller so the sensor wires will reach.
3. The sensors should be away from direct sunlight, as this may affect the readings.
4. The location should be where some water spillage will not damage anything. Preferably below the level of the controller.
5. Securely mount the bracket to wall using the two supplied screws.
6. Securely fasten all electrical, water and chemical lines.
7. Locate chemical feed pumps and chemical storage tanks in a safe and secure area.
8. Check filter daily for debris buildup and clean as needed.
9. To clean filter, turn both flow cell inlet and exit valves OFF, (see caution in paragraph above) remove filter cover and filter, being careful not to lose seal.
10. Clean stainless steel filter and return to housing being careful to seat it properly. The filter screen can be easily damaged if seated improperly when the cap is installed.
11. Maximum operating pressure = 25 lbs.
12. Extreme pressure variances may affect readings and can cause damage to the sensors.
13. Avoid installing the outlet before the main pump as the vacuum may damage the chemical sensors.
14. Only inject chemicals on the outlet side of the AK1200.
15. Do not over tighten fitting on flow cell top.

## Inlet and Exit Lines

1. It is essential that the supply line be at a higher pressure than the discharge line so the water will flow through the cell at a steady rate in the right direction. Installing a ball valve in the main circulation line may be required if the pressure is too low.
2. Inlet should be installed after filter and before heater.
3. Exit should be installed after heater and as far away from any equipment as possible.
4. Drill and tap at above locations with 7/16" drill and 1/4" NPT tap. Choose a location on a fitting where the pipe enters so you are drilling through both the pipe and fitting to get maximum depth of thread.
5. Install 1/4" NPT by 1/2" flex fittings then route inlet and exit lines.

## Sensors

1. Keep pH and ORP sensors wet at all times, install the sensors into the flow cell. Hand-tighten only and save caps for future use, fill flow cell with water. The sensors have O-Rings and don't require thread seal tape.
2. Route the flow switch wires into the controller through the strain relief and connect to the controller. One wire (either one) to ground and one to the appropriate input switch.

### CAUTION

The flow switch is a dry contact only. (No Current)  
Use with any other brand controller VOIDS WARRANTY

3. Route the chemical sensors into the controller through the strain relief and connect to the controller. The sensor wires are labeled and the plus and minus polarity must be observed.
4. Turn the main pump on and open the valves to test for leaks and the free movement of the magnet. The Magnet must be all the way up in order to close the flow switch. 1/4 GPM will push the magnet all the way up.

### WARNING

Make sure that all pumps are OFF before drilling into pipes.

### WARNING

Never turn chemical feed pumps on when both  
flow cell valves are closed..

## Section 5 Sensors

The Controller can accept readings from a wide variety of sensors. The sensors that the Controller is able to read depend on the sensor module installed in the controller. Each sensor has its own unique circuitry that is connected directly to the micro-controller for measurement. The pH, ORP, PPM and conductivity sensors are isolated from each other and from the input power. Isolation of each sensor ensures more accurate measurements.

The Controller measures the following sensor measurements with the listed characteristics:

1. pH
  - Range: 4.22 to 9.78,  $\pm 0.02$ .
  - This measurement is temperature compensated.
2. ORP
  - Range: 0 to 999 mV,  $\pm 1$ mV.
3. Conductivity
  - Range: 0 to 9999  $\mu$ S.
  - This measurement is temperature compensated.
4. Temperature
  - Range: 32 to 212  $^{\circ}$ F,  $\pm 0.02$ .
5. Flow Switch
  - This input measures if a switch is open or closed.
6. Flow Rate (1 to 6 inputs);
  - Range: 0 to 5000 gallons per minute.
7. Pressure (1 to 4 inputs),
  - Range: 100 PSI,  $\pm 0.1$ PSI.
  - The Controller has 12VDC available to power the sensor.
8. AKColor Colormetric PPM Sensor
  - Range 0 to 8 PPM

### **WARNING**

Sensors are shipped with a protective cap covering the electrode tip to protect the sensing element. Sensors should be kept in the protective cap until ready for installation, if the sponge in the cap becomes dry, wet it with tap water. During shipment, air bubbles may have entered the electrode, carefully shake the electrode downward (like a thermometer) to dispel the air from the sensing elements inside the electrode. Before using the sensor, remove the cap.

## pH and ORP Sensors

pH electrodes sense the acidity of the water and work with any acid or base. The blue bands on the cables identify the pH sensors. Each sensor is also identified on the sensor body. ORP electrodes are used to monitor the Oxidation-Reduction Potential (sanitization quality of the water) of a given solution. The sensing element of the ORP electrode is made of a precious metal such as platinum or gold. The red bands on the cables identify ORP sensors.

The polarity (+ and -) of the pH and ORP sensors must be observed. The ORP sensor (+) is color-coded red and the pH sensor (+) is color-coded blue, and the green leads are (-) polarity coded. Leave excess wire outside the controller enclosure. **Do not stuff excess wire inside the controller as this may cause excess strain on sensor and relay connections. Do not cut the sensor wires.** If the cable is longer than needed, it should be coiled neatly and attached under the controller enclosure.

## pH and ORP Sensor Care

Contamination of the sensing elements often results in slow response and inaccurate readings. Clean the elements by the following procedures:

### pH and ORP sensors

- Wash electrode tip in a liquid detergent and water. Carefully use a soft bristled toothbrush to wash the electrode tip and white sensing ring.
- Rinse after cleaning. To install, place in flow cell according to the diagram and hand tighten.
- Make sure the O-ring is installed on sensor.
- If the cable is longer than needed, it should be coiled neatly and attached under the cabinet.

### pH Sensors Only

- Attempt to clean the sensor with liquid detergent first.
- If this is not successful, swirl the tip of the sensor in a 5 parts water 1 part muriatic acid solution for 10 - 20 seconds.
- Rinse again and reinstall.

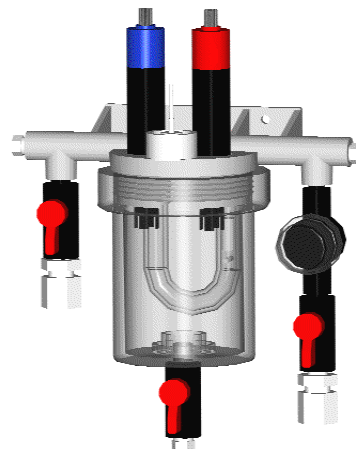

---

## Flow Sensors

The Controller can accept information from two types of flow sensors:

- 1) Flow switches
- 2) Digital flow sensors.

Each AK610, 611, and 613 sensor module has three (3) flow inputs. The first flow input, FS1, must be a flow switch. The Second and third flow inputs, FS2 and FS3, can be either a digital flow sensor or a flow switch.

The AK612 and 617 pressure sensor modules have five flow inputs and are primarily used for backwash operations. Each of these five flow inputs must be a flow switch. This sensor module is not compatible with digital flow sensors.

When installing a digital flow sensor, follow the instructions that come with the sensor. Most digital flow sensors will have three different colored wires. One will be a positive wire, which provides the supply voltage for the sensor.

1. The wire with the positive charge should be installed in the connection on the sensor module labeled +12.
2. The second wire will be a ground or negative voltage wire. This should be connected to the ground connection on the sensor module.
3. The third wire, the signal, should be connected to either the FS2 or FS3 slot.

## Pressure Sensors

The AK612 or AK617 sensor modules have the ability to receive signals from up to four amplified pressure sensors. The Controller can accept readings from any pressure sensor that has an output of 0.500 volts at 0 PSI, and 4.50 volts at 100 PSI. Pressure measurements can not be calibrated.

When installing a pressure sensor, connect the red wire to +12, the black wire to the ground and the white wire to the pressure input on the AK612 or AK617.

## Finishing your Installation

To following outlines some finishing touches needed for any good installation.

1. Verify the programming in the Controller
2. Balance the water to your desired set point.
3. Turn the Controller on, and allow it to begin automatically controlling the water balance.
4. Calibrate all sensors to the balanced water.
5. If the sensors have not finished acclimating to the system water, recalibrate the sensors the following day.
6. Call or visit several times over the next few days to fine-tune the setup and programming.
7. Submit the registration card for your controller to Acu-Trol.

## Section 6 Operations

### Introduction

This PROGRAMMING GUIDE introduces and describes all the available screens and menus of the Controller, from navigating and initializing the screens to programming and customizing specifications. If you have any questions after reading through this manual, please contact your local Acu-Trol dealer for further assis-

### Navigating in the Controller Chemical Controller

The Controller has a touch screen display, similar to a PDA or an ATM machine. All of the menus in the Controller are accessed using this touch panel display. The touch screen display should be operated using the plastic stylus included with the controller. Hold the stylus as you would an ordinary pen, being careful not to touch the display with fingers. Do NOT exert pressure when using the stylus or you may damage the display.

#### WARNING

Using a pen or other sharp object on the touch screen will damage the display.

There are three main menu selections in the Controller, DISPLAY, CONFIG, and SERVICE. All other menu selections are contained in these three main menu choices. To Access one of these three main menus, touch the menu title with the stylus. Note: The small xx on the top right-hand side of the screen can be used to back out to the previous screen. Touching the left corner (hidden symbol) will exit out all the way back to the main menu.

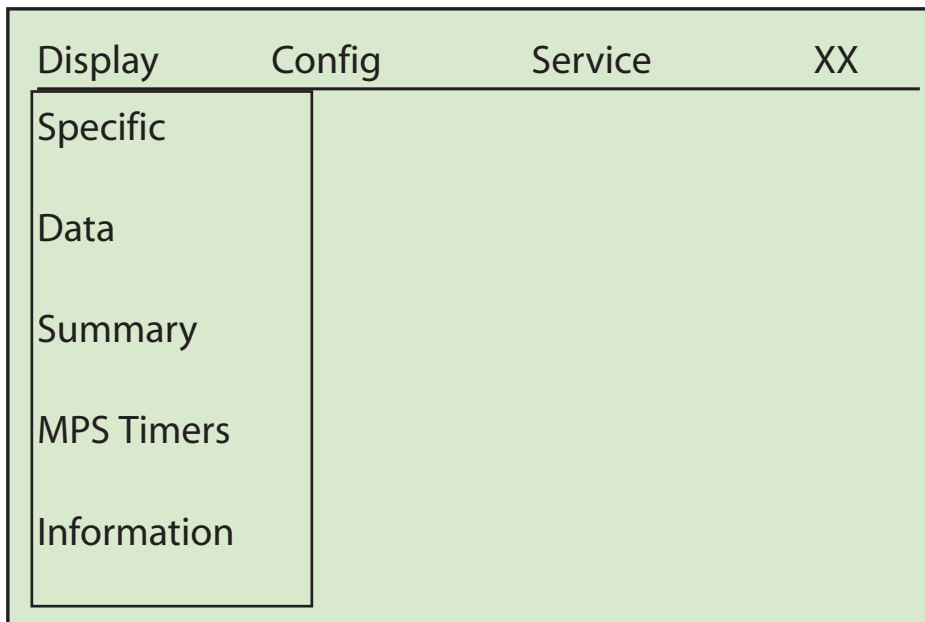



---

## Selecting Items

The Controller offers the option to make changes or to customize the screens. There are several methods for selecting menu items in the menu screens.

The System menus are accessed by touching the menu item title directly on the screen. In this manual, System menus are always in BOLD CAPITAL LETTERS. There are three system menus in the Controller, DISPLAY, CONFIG, and SERVICE.

Each main menu contains a series of related sub-menus. Sub-menu titles will always be in Bold Letters. To access these sub-menus, touch the sub-menu title with the stylus.

Some of the sub-menus include on-screen buttons. On-screen buttons are indicated in this manual in Bold Italic Highlighted Letters. On-Screen buttons are used to organize large sub-menus into categories. Touching an on screen button will open up a smaller section of a sub-menu. All of the items contained in a button menu will be related to a specific part or function of the controller.

A few of the buttons in the Controller are multifunction or toggling buttons 

These buttons are used in cases where there are a limited number of specific choices for a certain setting or program parameter. Pressing one of these buttons changes the button label as well as the current controller setting. Multifunction or toggling buttons will be shown in Regular Italic Highlighted Letters.

When there is a list of 7 or more items to select from, a set of directional arrows will appear at the bottom of or on the right side of the screen. These arrows are used to scroll through the list of choices. The current item will be highlighted as you scroll. When directional arrow keys appear at the top right of the screen they are used to access the previous and/or next screen.

## Changing Item Values

The Controller offers several ways to change or input information in the controller. The method you will use to change a value will depend upon the type of value it is and the number of choices available for that variable. Some items will have a limited number of specific choices. In this situation a Change button will appear at the bottom right hand corner of the screen. Once you highlight the item you wish to change using the directional arrows, pressing the Change button will scroll through the choices for that item. Once you reach the choice you wish to select, use the Enter or OK button to exit and save your changes.

Other items have a longer list of specific choices. For these items you will be shown the entire list of choices, along with directional arrows to help you scroll through the choices. Once the choice you wish to select is highlighted, press the Enter or OK button at the bottom of the screen.

Many of the settings in the Controller are completely user selectable. For these settings you may enter any combination of letters, numbers, and symbols. The controller will generally prompt you for a certain number of characters, and will reject characters that do not meet certain logical standards for that specific setting. Any setting that requires a user specified value will automatically launch the alphanumeric keyboard.

## The Alphanumeric Keyboard

The Controller includes an alphanumeric keyboard with capital letters, numbers and special characters. If the item being changed needs this keyboard it will appear and the current value or text will be displayed, ready for editing. The correct format for the value being entered is shown on the guide line above the text entry line.

To edit any character, touch the character with the stylus. Then use the alphanumeric keyboard to enter a new character or change the character above the underline. Use the Enter button at the bottom of the screen to save your changes.

The top line on the alphanumeric keyboard screen holds several shortcut buttons. The "CAPS" button is used to change from capital to lower case letters. When "CAPS" is displayed, the alphanumeric keyboard will display capital letters. When "caps" is displayed, the alphanumeric keyboard will display lower case letters. Touching the "CAPS" button with the stylus will toggle between the two choices. The "d" button can be used to delete or clear a character. The "I" button will insert a space for a character in between two existing characters. The ">" and "<" buttons are used to move the cursor right and left while editing the characters.

The Enter button saves your changes and closes the alphanumeric keyboard. If the values you have entered do not match the required format, an error message will appear. To return to the alphanumeric keyboard, touch the screen with your stylus. The Cancel button closes the alphanumeric keyboard without making any changes to the current settings and values. Once changes have been saved the only way to return to the original value is to re-enter it.

CAPS											x d I < >			
Enter Value (###)														
-> n														
Q	W	E	R	T	Y	U	I	O	P	@	&	7	8	9
A	S	D	F	G	H	J	K	L	:	-	=	4	5	6
Z	X	C	V	B	N	M	,	.	/	#	?	1	2	3
Cancel													0	.

## Initializing the Controller

Anytime the controller is turned on, the Controller will perform a brief check of its internal systems and load variables into memory for operation. After this check the controller will open the initialization screen and display the results of this check.

The initialization screen displays information about the controller. It will tell the operator the model of the controller, the version of firmware the controller is using, and display a list of detected hardware. This list may include modems, printers, sensor cards, and memory modules; the exact list is determined by the components in your controller. If the external memory module was previously installed and is now not detected, an error message will be displayed in the initialization screen.

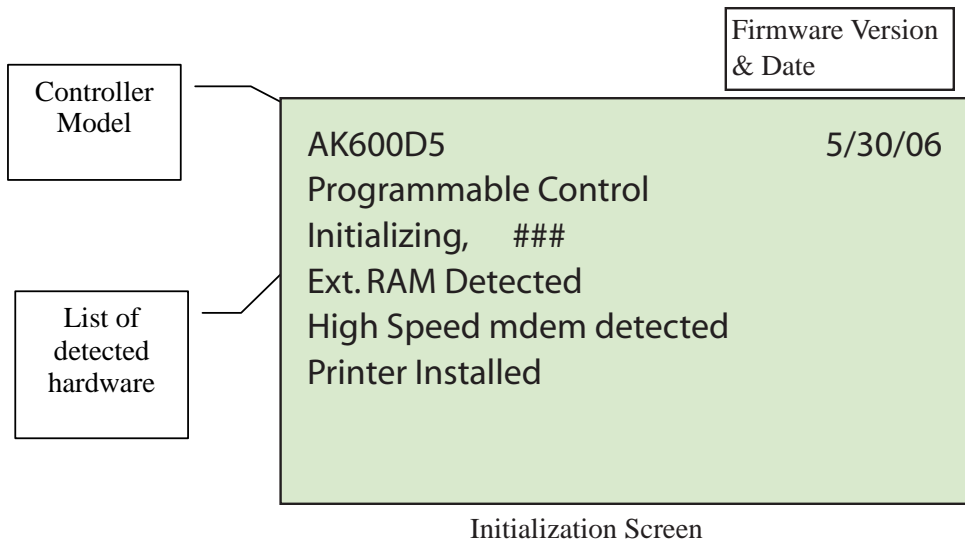

Once all initialization tests have been passed, the controller will automatically open the Dealer Information screen.



## Section 7 The System Menu

Once the controller has identified itself, it will open the system menu screen. The system menu screen displays the unique serial ID number for your Controller. It also displays the current time, day and date. The MPS status for the relays is also displayed on the system menu screen. This information will tell you if any relays have been changed to manual operation only, turned off, or globally disabled.

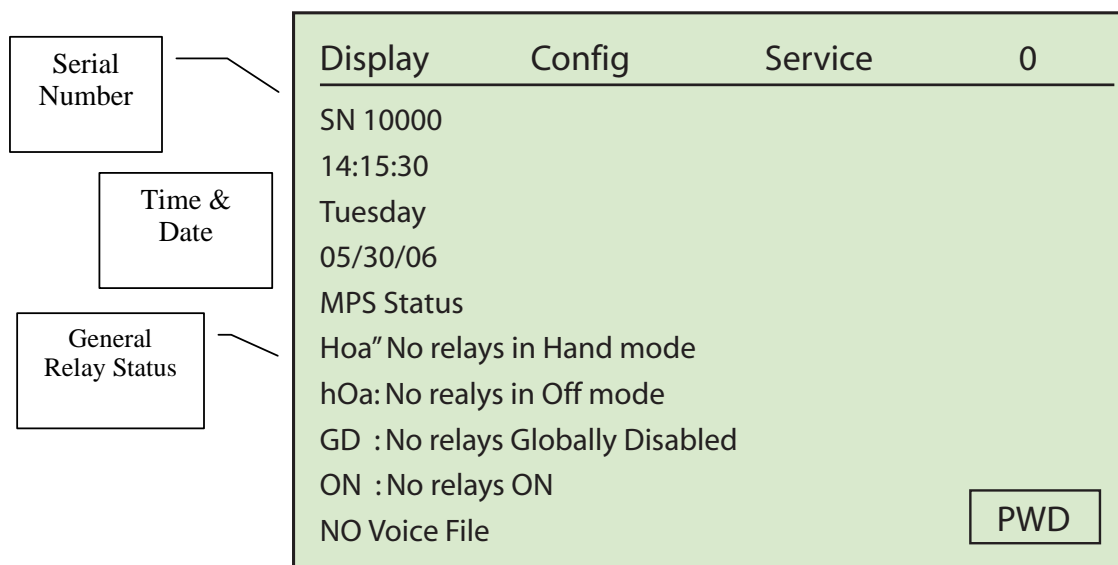

System Menu Screen

### NOTE

If the external memory is installed, but the voice file is missing or corrupt, the message "No Voice File" will be displayed on this screen.

### NOTE

The serial number, time day and date may be replaced with various warning messages and not always displayed on the system menu screen.

The Controller has many features to protect the security of your pool or spa. Your controller can be programmed with up to 7 passwords, providing 4 access levels. The default factory setting for the Controller does not have any passwords. You may choose to program passwords as a part of your set up. Once a password or passwords have been programmed, no one will be able to progress beyond the display menu without entering the password. To enter a password, press the PWD button on the bottom right hand corner of the system menu screen. The alphanumeric keyboard will automatically open for you to enter the password.

There are three menu headings on the System menu screen. These three menus, DISPLAY, CONFIG and SERVICE, are opened by touching the appropriate heading with your stylus. After touching one of the three system menu headings, a drop down menu will appear and display the sub-menus underneath each system menu.

## The Display Menu

The DISPLAY MENU has five sub-menus, Specific, Data, Summary, MPS Timers, and Information. Each of these sub-menus will help you to view the data captured by the Controller.

- The Specific sub-menu displays an overview of chemical levels and feed times for each pool or spa controlled by the Controller
- The Data sub-menu displays the data recorded from the sensors at a set interval.
- The Summary submenu displays the chemical levels for up to three pools or spas
- The MPS Timers submenu displays the status of each mini program
- The Information submenu displays information about the status of the Controller.

A more detailed description of each display submenu will follow this section.

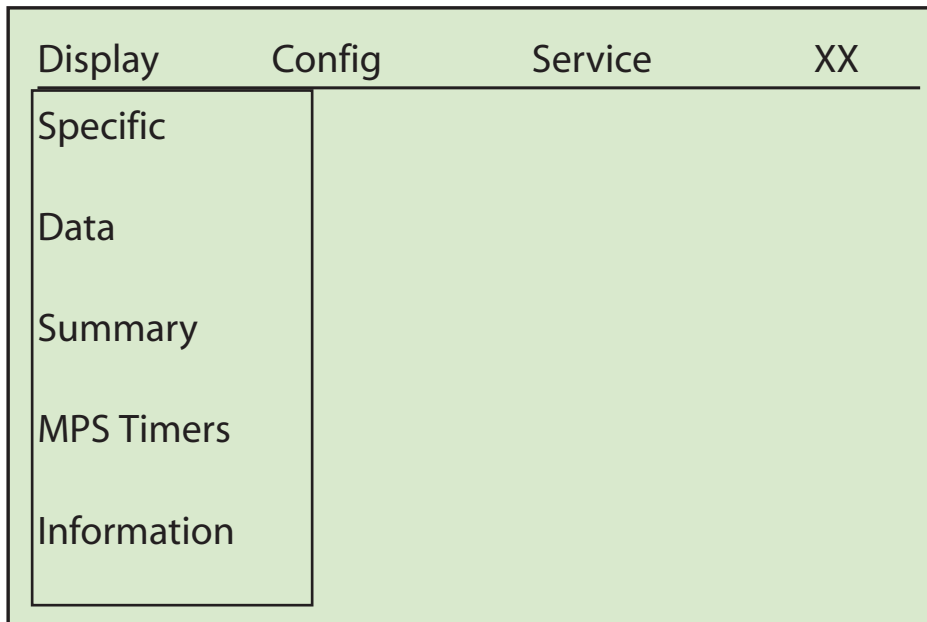

Display Menu

## The Specific Display Screen

The Specific Screen displays an overview of the current chemical levels and feed times for one pool or spa. When the Controller is controlling more than one pool or spa, a series of numbers will appear next to the screen title, System. These numbers correspond with a specific body of water. To view information on a specific pool or spa, press the corresponding number in the screen heading.

System	1	2	3	XX
ITEM	Meas	Set	On Today	Flow
pH1	7.06 <input type="checkbox"/>	7.50	00:00:00	1 <input type="checkbox"/>
ORP	486 <input type="checkbox"/>	700	02:23:26	2 <input type="checkbox"/> 3 <input type="checkbox"/>
Temp1	77.5 <input type="checkbox"/>	76.9	01:36:17	
P1L	0.0			
P1H	2.9			

Specific Screen

The specific screen can display measurements from eight sensor inputs. The controller will display the name of each sensor input along with its current measurement, the user specified set point, the time the corresponding feed devices have been on in the last 24 hours, and whether the flow to the system is on or off. You may change the order that the sensor displays this information in.

Each column on the specific screen serves a specific function. The Controller is designed so that the operator can find the current measurement for each sensor input quickly and easily. The name of each sensor input being received is displayed under the ITEM heading.

All current measurements are displayed under the Meas heading. The box next to the current measurement is used to display whether the corresponding relay is currently on or off. An X in this box indicates that the relay is currently on. An O in this box indicates that the feed relay has already been on for its maximum allotted time. This is called an overfeed alarm. The controller will not allow this relay to feed more chemicals in to the system until the overfeed timers are reset. An "a" to the left of the relay status box indicates that an alarm condition for that relay exists.

The ON TODAY heading displays the total time that the associated relay has been on since the controller was reset. The Controller factory default settings will reset the controller every 24 hours at 8:00 am. The controller can also be manually reset.

The Flow column is used to indicate whether or not there is flow in the system. When there is flow an X will appear in the box. The box will be empty if no flow is detected.

If the Controller has any kind of alarm it will alert you here. The controller will display the alarm condition, as well as the relay that has met or exceeded this condition. More information about specific alarm codes may be found on p. .

## The Data Display Screen

The Data Display screen displays recorded data from selected sensors. The operator has the ability to choose how often the controller will record its readings. The Controller can record data at any interval in the range of two (2) seconds to eighteen (18) hours. In the absence of power, the Controller retains all recorded data and program values for up to ten (10) years.





Mm/dd	hh:mm	pH1	ORP	PPM1	Temp	xx
05/30	14:00	7.06	485	1.01	77.7	
05/30	13:00	7.06	486	1.02	77.5	
05/30	12:00	7.06	486	1.01	77.7	
05/30	11:00	7.05	485	1.02	77.8	
05/30	10:00	7.05	485	1.03	77.7	
05/30	09:00	7.05	486	1.05	77.9	
05/30	08:00	7.06	475	1.01	78.7	
05/30	07:00	7.06	475	.95	80.3	
05/30	06:00	7.07	470	.91	80.5	
05/30	05:00	7.07	473	.90	79.7	

Data Display Screen

The Data Display screen will show up to 10 lines of recorded readings at a time. The controller will automatically display the 10 most recent recorded data lines. Each line of data contains the time and date of the recording, and the sensor readings at the time the record was made. Sensor data readings from Modules 1-3 may be obtained by touching the desired module one, two or three (1, 2, or 3), on the bottom right hand portion of the screen.

The status code of the flow, alarm, remote, modem, and password security level for all three sets of sensors are recorded during each reading. To view these status code readings, usually referred to as the FARMP readings, use the right arrow button  while in the data display screen. The status code reading is displayed under the first letter of the device name.

- F
  - o the Flow status code,
    - Records whether the flow was on or off at the time of the reading.
      - 1 = Flow
      - 0 = No Flow
- A
  - o the Alarm status code,
    - Records whether or not any alarms were on at the time of the reading.
      - 1 = Alarm
      - 0 = No Alarm
- R
  - o the RS232 status code,
    - Records whether an RS232 connection was in use since the last reading.
      - 1 = RS232 Connection in use
      - 0 = RS232 Connection not in use
- M
  - o the Modem status code,
    - Records whether or not the installed modem was in use since the last reading.
      - 1 = Modem in use
      - 0 = Modem not in use
- P
  - o The user determined password level
    - Records the pre-determined password level of anyone using the controller since the last reading.
- B
  - o The Backlight Status
    - Records Whether or not the touch screen backlight was on at the time of the reading.
      - B = Backlight on
      - = Backlight not on
- W
  - o Sensor Warning
    - Sensors may have been over calibrated or need to be replaced
      - W = Sensor Warning
      - = no sensor warning

The Controller has the ability to store 6505 lines of data, the equivalent of 271 days of hourly recordings. To view more data measurement lines, you can scroll line by line using the up and down arrow     buttons on the bottom of the screen. To scroll more quickly through the data, the page down PD and page up PU buttons will move your view up or down a page. A page in the data display screen is the equivalent of 10 lines of data. To find data from a specific day, the day down DD button will take you to the first reading of the previous date and day up DU buttons will move you to the first reading of the following date. To see additional information on the same line, use the left and right arrow buttons.



## Program the Data Recording Interval

The factory default data recording interval is one hour. To change the data recording interval start in the system screen. Open the CONFIG menu by pressing on the heading with your stylus

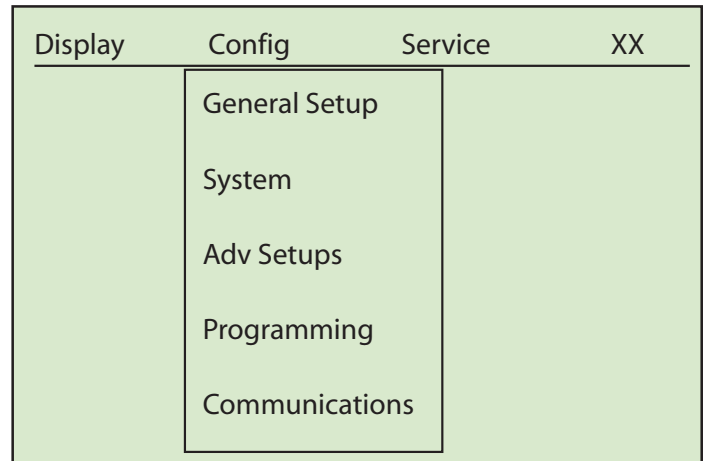

Open the General Setup Menu by pressing on the menu title with your

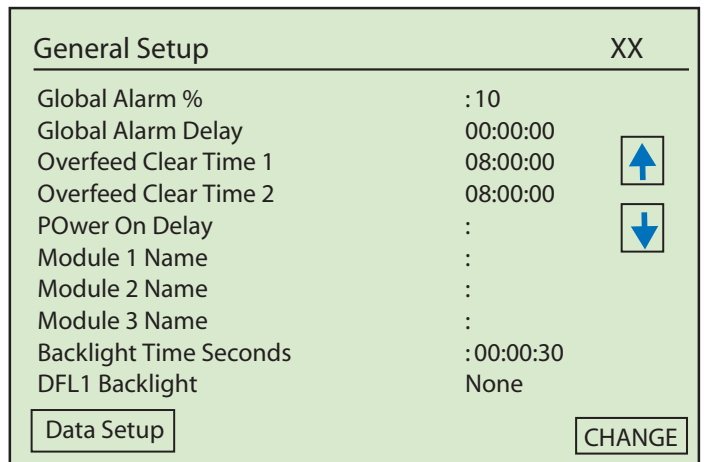

Open the Data Setup menu by pressing the Data Setup button.

The Data Setup menu will open with the time spacing already highlighted. Press the change button with your stylus. The alpha numeric keyboard will automatically open and prompt you for a new data recording interval.

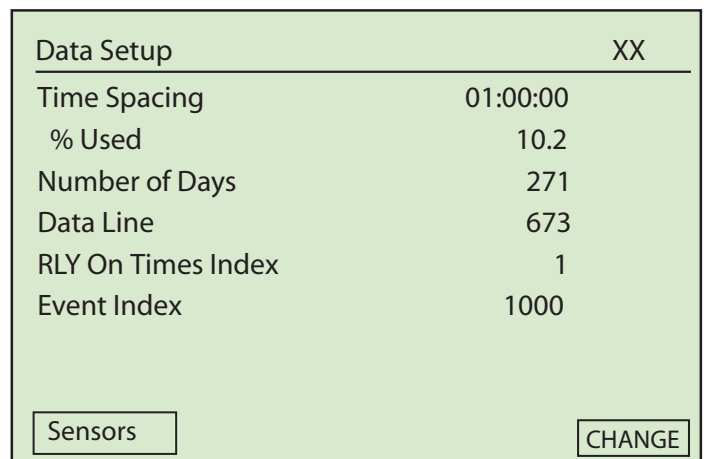

## Summary Display Screen

The Summary Screen provides a brief overview of the sensor readings and relay status for all systems controlled by the Controller. For each system, the Controller will display the current pH reading, the current ORP reading, the current temperature, the feed relay status, and the flow status for each individual system.

SYS 1			SYS 2			SYS3			XX											
pH1	7.06	<input type="checkbox"/>	pH1	7.06	<input type="checkbox"/>	pH1	7.06	<input type="checkbox"/>												
ORP1	486	<input type="checkbox"/>	ORP1	486	<input type="checkbox"/>	ORP1	486	<input type="checkbox"/>												
TEMP	77.5	<input type="checkbox"/>	TEMP	77.5	<input type="checkbox"/>	TEMP	77.5	<input type="checkbox"/>												
F1	<input type="checkbox"/>	F2	<input type="checkbox"/>	F3	<input type="checkbox"/>	F1	<input type="checkbox"/>	F2	<input type="checkbox"/>	F3	<input type="checkbox"/>									
NEXT	R1-R12:	x																		PWD

Summary Screen

The Controller will display the status of the feed relays controlling the chemicals to the system. The feed relay status is displayed in a box to the right of the current sensor reading. If the feed relay status box has an "O" inside, the relay assigned to this sensor is in overfeed and will not turn on again until the overfeed timer is cleared. An X in the feed relay status box indicates that the relay is currently on. On occasion a letter "a" will appear to the right of the feed relay status box. This "a" indicates that the feed relay is in alarm.

The summary screen also displays the flow switch status for each system. The flow status is located on the bottom left hand side of the summary screen. The system is identified by an F and then the number of the system, 1, 2, or 3. The box to the right of the System number is used to display the status of that system. An "X" will appear in this box when there is flow in the system.

The status for each of the first 12 relays in the Controller is displayed along the bottom of the summary screen. There are twelve individual boxes. The order of these boxes is the same as the numbering scheme of the relays: relay one status is displayed in the first box, relay 12 status in the last box, etc. When a relay is on an "X" will appear in its specific box.

The summary screen will be slightly different depending on the types of sensors and devices you have installed on your Controller. If the Controller has been set up to work with an AK Color system with an AK615 or AK616 sensor module, the letter "c" will appear to the right of the SYS 3 heading. For more information on the AK Color refer to Section 12.1.

The summary screen also contains a brief overview of information that can help you to maintain your water balance. The Water balance screen is reached by pressing the NEXT button at the bottom right hand corner of the summary screen.

	SYS 1	SYS 2	SYS 3	XX
Alkalinity	80	80	80	
Hardness	450	450	450	
TDS PPM	1500	1300	1500	
Cyanuric	0	0	0	
Langelier (LSI)	0.0 B	0.0 B	0.0 B	
Puckorius (PSI)	7.55 B	7.55 B	7.55 B	
Ryzner (RSI)	7.06 C	7.06 C	7.06 C	
NaCl PPM	27647	27647	27647	
B = Balanced      C = Corrosive      S = Scaling				
<input type="button" value="NEXT"/>				

Water Balance Screen

The Controller will calculate your waters score on several water balance indices based on the sensor measurements and some values that must be entered by the operator. A "C" will appear next to any index value that indicates your water is corrosive. A "B" will appear next to any index value that indicates your water is balanced. An "S" will appear next to any index value that indicates your water is scaling.

NET	CH1	CH2	CH3	CH4	SW1234	xx
1	0	0	0	0	0000	
2	0.0	0.0	0.0	0.0	0000	
3	0	0	0	0	0000	
4	0	0	0	0	0000	
5	0	0	0	0	0000	
1	0	0	0	0	0000	
2	0	0	0	0	0000	
3	0	0	0	0	0000	
4	0	0	0	0	0000	
5	0	0	0	0	0000	
<input type="button" value="NEXT"/>						

Summary / RS485 Screen

Touching NEXT again will take you to the RS485 network screen. These screens allow you to view sensor values of any networked sensors. The Controller can display information from five networked sensors. The RS485 network screen is actually two screens combined in to one display: the first five lines on the screen displays the sensor values, and the

**NOTE**  
If no network items are installed, the NEXT button takes you back to the summary screen.

## MPS Timers

The Controller contains 16 physical relays and 8 soft relays. Physical relays are used to control the devices in your pool room. Soft relays are used to expand the capabilities of the relays and can be used to program the controller to react to the conditions created by the physical relays.

The relays in the Controller are organized in to five distinct groups. The physical, or R relays are used to control physical devices attached to your controller. “R” relays are numbered 1 through 16. Soft relays, or S relays are used to run operations where more than one device is involved. “S” relays are numbered 1-8. Alarm or A relays are used to turn on an alarm condition when user specified conditions are met. “A” relays are the alarm relays, numbered 1-4. Pager/Voice/Email relays, or PVE relays are used to tell the Controller to call a specific pager number and to send it a user specified numeric string of information. “P” relays are numbered 1-8. V relays are the voice relays, numbered 1-16.

To view the status of a specific group of relays, use the appropriately lettered button at the bottom of the MPS Timer Screen. The MPS timers for the relays in the Controller are displayed in groups of four. The MPS timers are grouped numerically by relay group when displayed. The first four R MPS timers will always be displayed first. To view other timers, press the NEXT 4 button on the bottom right of the screen. This button will scroll forward to the next group of four MPS timers. To scroll backwards, use the PREV 4 button on the bottom left of the MPS Timers screen.

MPS#	TOTAL	ON-TODAY	TIMER	xx
R 1	0000:13	00:00:00	00:00:00	
	Day Count: 0		Cnt: 0	
R 2	0006:51	00:12:20	00:00:39	
	Day Count: 0		Cnt: 348	
R 3	0000:19	00:00:00	00:00:00	
	Day Count: 0		Cnt: 0	
R 4	0002:22	00:18:17	00:00:10	
	Day Count: 1		Cnt: 237	
<div style="display: flex; justify-content: space-around; align-items: center;"> <span>[ R ]</span> <span>[ S ]</span> <span>[ A ]</span> <span>[ PVE ]</span> </div>				
<div style="display: flex; justify-content: space-between; align-items: center;"> <span>[ PREV 4 ]</span> <span>[ OK ]</span> <span>[ NEXT 4 ]</span> </div>				

MPS Timer Screen

Mini Programs are used to control all the relays in the Controller. These mini programs tell the controller which relay to turn on, when to turn them on, how long they should stay on for, and how long to wait before turning on again. They can also tell the controller to page or call a specific technician when a specific condition occurs.

---

The Controller uses up to forty-four (44) Mini Programs (MPS) to determine which relays, alarms and pagers should be ON or OFF. Each relay in the Controller can be operated with any one of the 44 mini programs. Relays in the Controller are configured at the factory to accept any of the mini programs and function with the selected program. More information about selecting an MPS for each relay in use can be found in the section on programming, located on p.

The MPS timers screen is often used when troubleshooting the programming of the Controller. This screen can be used to determine how long each relay and its associated device have been on since the controller was last reset, the total time the relay has been on for the current date, and the amount of time remaining until the relay turns on or off again.

The TOTAL column in the MPS timers Screen displays the total time that each relay and the associated device(s) have been on since the last controller reset.

The ON-Today column displays the amount of time that each relay has been on for the current date.

The TIMER column displays the amount of time left until the relay will turn on or off, depending on its current state. The current state of each relay is displayed in the box at the end of each row.

An empty box indicates that the relay is currently off and the timer is counting down until the relay turns on again.

A box with an "X" in it indicates that the relay is currently on and the timer is counting the time until the relay turns off.

This screen also displays the CNT or count, the number of times the relay has turned on since the settings were last cleared.

## Information Screen

The Information Screen contains system information about the operation of your Controller. This screen provides information on how long the controller has been in operation, its serial number and the date of the last software update.

AK600D5 5/30/06		xx
1. Power On Cycles		32
2. Total Hours On		1056
3. Serial Number		10000
4. Future		
5. MPS Delay		0
6. Relays On		1
7. Watchdog Timer:		0
8. Constant Checksum		###
9. FAULTS:	NO SYSTEM FAULTS	
10. Model	AK600D5 (Date)	
11. F1= gpm, Tot = kgal, Temp = Far		

### Information Screen

1. Power ON Cycles. A power cycle is a change in the power status, from on to off or off to on. The Controller counts and displays the number of times the power to the controller has been turned ON.
2. Total Hours ON: The Controller counts and displays the total number of hours that it has been in operation. The hours of operation are not cleared if power to the controller is cycled or lost.
3. Serial Number: The unique number for this controller. Enter this number on the warranty registration card and return to Acu-Trol immediately.
4. MPS Delay: This displays the number of seconds the controller will wait before turning any relay on. To ensure proper relay function, this number must be zero (0). During the initialization and power up phases of operation, This delay is temporarily set at thirty (30) seconds to allow sensor readings to adjust to the current water conditions before it attempts to make any adjustments.
5. Relays ON: This displays the number of relays that are currently on.

- 
7. **Watchdog Timer.** The Controller has several built in programs that observe the functions of the controller and ensure that the controller is functioning properly. The watchdog timer monitors the Controller for unexpected operations. If the Controller has an error, the watchdog timer will reset the system and clear the error. The Information screen displays how many times this watchdog reset has occurred.
8. **Faults:** System faults in the Controller are rare: this line generally reads NO SYSTEM FAULTS. If an internal system fault occurs, this line will display information about the fault. Each fault has a specific failure code. The message indicates which fault is present. Controllers with a system fault will generally not function properly. Contact your local Acu-Trol dealer for assistance.
9. **Model:** Displays the current software version in the controller, and the date that software was released.
10. **Fl=gpm, Tot=kgal, Temp=Far:** This line indicates the units that the controller is currently configured to display Flow Rate, Total Flow, and Temperature in. The Controller can display this information in standard or metric units. The controller must display all of these measurements in the same measurement system. You will not be able to display some information in standard

## Section 8 The Configuration Menu

The CONFIGURATION MENU contains all of the sub-menus that allow the user to program and customize the Controller. When programming or organizing the Controller it is important to remember that all changes are automatically saved. There is no way to reverse selections once they have been made. Cycling the power to the Controller will not reset the programming in the controller.

The CONFIGURATION MENU contains these sub-menu options: General Setup, System, Adv Setups, Programming and Communication.

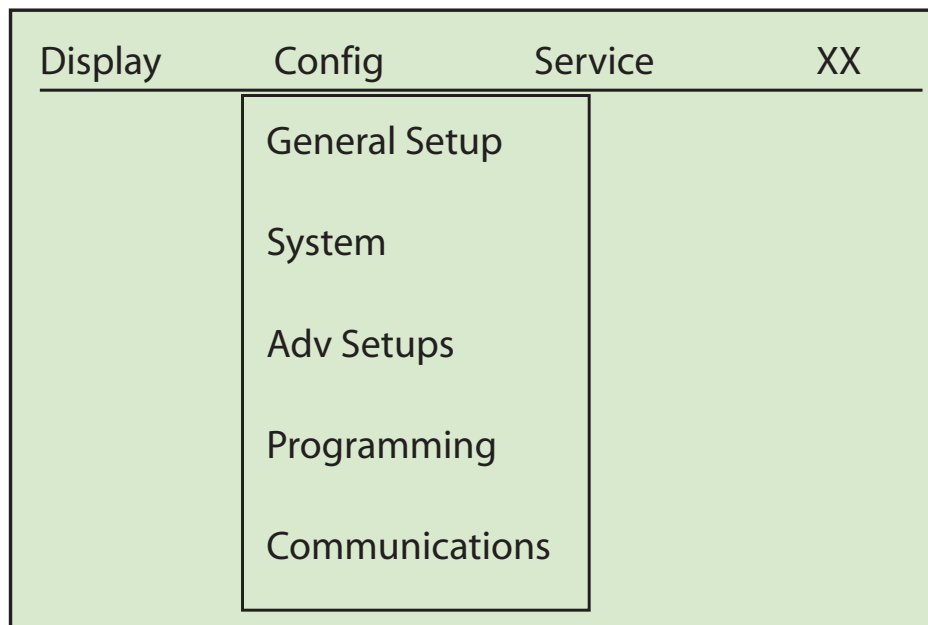

Configuration Screen



To access each of these sub-menus, touch the display on the item you would like to look at or change.

### General Setup Screen

The General Setup screen is used to set up the basic parameters of operation for your Controller. This screen is used to set alarm parameters, the overfeed reset time, and to name each system for easy identification. The General Setup screen also contains the Data Setup Submenu.

The General Setup menu contains eight menu items, which are discussed in detail in the next few sections. These menu items contain no sub-menus. To change the settings of these items, use the up and down arrows on the right side of the screen to scroll through the menu items. The current menu item will be highlighted. When you reach the menu item you want to select, press the CHANGE button with your stylus. Settings in the General Setup screen need to be entered carefully. These settings are used in many of the Controller's functions, and an incorrect value will complicate the troubleshooting process and could result in an incorrect reading.



General Setup		XX
Global Alarm %	: 10	
Global Alarm Delay	00:00:00	
Overfeed Clear Time 1	08:00:00	
Overfeed Clear Time 2	08:00:00	
POwer On Delay	:	
Module 1 Name	:	
Module 2 Name	:	
Module 3 Name	:	
Backlight Time Seconds	:00:00:30	
DFL1 Backlight	None	
<input type="button" value="Data Setup"/>		<input type="button" value="CHANGE"/>

General Setup Screen

### Global Alarm %

The global alarm percentage is the most basic alarm condition in the Controller. The user sets the global alarm percentage. The Controller monitors the chemical measurements, and then compares them to the set point. The global alarm percentage is used to calculate an acceptable operating range for the chemicals in the system. The acceptable operating range is the global alarm % above and below the set point. If any of the chemical measurements are outside of this acceptable operating range, the Controller will activate the alarm.

The Global Alarm % is measured in percentage units. The factory default global alarm % is 10%. To change the global alarm percentage, highlight the item using the up and down arrow buttons. Once highlighted, press the CHANGE button. The alphanumeric keyboard will automatically appear and allow you to enter a new global alarm percentage. Once you are done entering the new global alarm percentage, press the ENTER button to save your changes.

The Specific display screen and the Summary display screen both display the letter "a" next to a sensor measurement if the measurement is far away from the set point. This acceptable operating range is based on the global alarm percentage. The letter "a" alarm indicator is always based on the alarm percentage, even if

### Global Alarm Delay

Some fluctuation of the chemical levels is normal in every body of water. A reading outside of the acceptable operating range may soon be corrected by the scheduled addition of chemicals to the water. To allow the controller time to react to the situation as well as time for new chemicals to mix in to the system, the Controller will delay activating its alarm LED and any programmed pager routines for a specific period of time.

The Global Alarm Delay is measured in seconds. The factory default global alarm delay is ten (10) minutes. To change this value, use the up and down arrow buttons to highlight the global alarm delay menu item. To select, press the CHANGE button. The Controller will automatically launch the alphanumeric keyboard and prompt you to enter the new value. Once you are done entering the new global alarm delay, press the ENTER button to save your changes.

The Global Alarm Delay behaves differently from the Global Alarm %. This delay is only used when the Programming/Alarm/Wiz is reset. In the programming for the alarm the delay that is used is the Global Alarm Delay. If the delay is changed in the Config/General menu there is nothing else that has changed and the original alarm delay is still in effect. To use the new delay go to the Programming/Alarms and either use the “WIZ” button to reset all parameters for the selected alarm to defaults with the new delay, or edit the Alarm and manually change the delay. The delay has no effect on the ‘a’ that appears next to the measurement in the display screens. Whenever the measurement is out of the range of the Alarm % the ‘a’ will appear.

### Overfeed Clear Times

The Controller bases much of its programming on a 24 hour clock. All of the timers in the Controller are set to meet certain criteria within 24 hours. To maintain operations, the controller must clear and reset these timers every twenty four hours. There are two overfeed clear times in the Controller. To have the controller clear the timers just once per day, set both Overfeed clear times to the same time.

The factory default Overfeed Clear Time 1 and 2 are set for 8:00 a.m. However, it is possible to set the overfeed clear time to any hour of the day. When the current time matches the Overfeed Clear time, the overfeed timers will be cleared and any appropriate data saved. To change the overfeed clear time, use the up and down arrow buttons to highlight the appropriate Overfeed Clear Time menu item. To select, press the CHANGE button. The Controller will automatically launch the alphanumeric keyboard and prompt you to enter the new value. Once you are done entering the new overfeed clear time, press the ENTER button to save your changes.

*NOTE: The Controller's Overfeed feature is equivalent to the amount of time the chemical feeders will feed during an alarm condition.*

### Module 1, 2, or 3 Name

The Controller has the ability to control up to three bodies of water. This means that your Controller will be displaying 3 ORP values, 3 pH values, etc. In order to make it easy to assign measurements to a specific body of water, it is possible to give each body of water a name, instead of relying on memory to identify which system number belongs to which body of water.

To change the system name of a body of water, use the up and down arrow buttons to highlight the Module 1, 2, or 3 menu items. To select, press the CHANGE button. The Controller will automatically launch the alphanumeric keyboard and prompt you to enter the new system name. Once you are done entering the new system names, press the ENTER button to save your changes.

### Backlight Time

The Controller has a backlight built in to the touch screen display. The backlight will automatically light any time the touch screen is pressed. The length of time that the backlight is on after the screen has been touched can be programmed by the operator.

The factory default value for Back Light Time is 30 seconds. To change the back light time, use the up and down arrow buttons to highlight the Back Light Time menu items. To select, press the CHANGE button. The Controller will automatically launch the alphanumeric keyboard and prompt you to enter the new back light time. Once you are done entering the new backlight time, press the ENTER button to save your changes.

## DFL1 Backlight

The Controller is configured to allow a user to turn on the Controller backlight with an external switch instead of the touch screen. The external switch can be wired in to the controller using the DFL1 slot in any one of the three systems (or modules) installed in the Controller. In order for the external switch to work properly, you will need to tell the Controller in which slot you have installed the switch.

To select the switch slot for the DFL1 backlight, use the up and down arrow buttons to highlight the Back Light Time menu items. To select the module that the switch has been wired to, press the CHANGE button. This will toggle the selection between the three available modules and none (no external switch installed). When you reach the appropriate module, exit the screen.

## Data Setup

The Controller has the ability to store 6505 lines of data, the equivalent of 271 days of hourly recordings. These readings can be viewed in the Data Display Screen. (For more information please see p. 37) The DATA SETUP button located in lower left corner of General Setup screen is used to access the Data Setup Menu. This menu allows the operator to view information about the data records, and to set the time interval for data recording. The Data Setup menu also contains the SENSORS button, which opens the Sensor Setup sub-menu.

Data Setup		XX
Time Spacing	01:00:00	
% Used	10.2	
Number of Days	271	
Data Line	673	
RLY On Times Index	1	
Event Index	1000	
Sensors		CHANGE

Data Setup Screen

### Time Spacing

The time spacing in the Data Setup menu is the Amount of time between recordings. The time between recordings in the Controller can range from two second intervals to eighteen hour intervals. The factory default setting has the Controller record the sensor readings once per hour. The time spacing is the only value in this screen which can be changed. All the other menu items are information to help the operator manage the data memory.

## % Used

This line displays the percentage of the data memory that has been filled. When 100% of the data memory has been filled the controller will begin to record over the existing data, oldest data first.

## Number of Days

The Controller will use the user specified time spacing to calculate the number of day's worth of readings that the memory will hold. Once calculated, the Controller will display this information here.

## Data Line

The Controller will display the number of the data line that will hold the next recording. The Controller has 6700 available data lines. When all the data lines have been filled, the Controller will begin to record over the existing data, deleting the oldest data line first.

## Relay On Times Index

The Relay On Times Index is an incremental record of the number of times the relay on times have been saved. When the overfeed timers reset themselves, the controller saves the relay on times for future use, and increments the Relay On Times Index. The Relay On Times Index can range from 1 to 365.

## Event Index

The Event Index is only available on controllers that have the Controller memory module installed. The Event index will record the number of times each relay is turned on or off. These power cycles are recorded in to the expanded memory along with the date and time of the recording.

Only Controller's with Expansion Memory module can use the Event Index. The event index is a timed record of every ON and OFF cycle that relays 1 – 16 go through. When relay #1 turns on an entry is made in the index noting the time and date and the current state of all relays. Later when relay #1 turns off another index entry will be made.

The example below is an actual section from a data index. The first column is the date, the second is the time, and the next sixteen columns are the ON/OFF state of relays 1-16, A "0" means that the relay was OFF and a "1" means that the relay was ON. According to the index relay #4 came on at 09:34:48 and turned off at 09:34:52. So the total on time was 4 seconds.

```

                                     111 1111
Date      Time      1234 5678 9012 3456
05/07/6002 09:34:52 0000 1100 0000 0000
05/07/6002 09:34:48 0001 1100 0000 0000
05/07/6002 09:32:28 0000 1100 0000 0000
05/07/6002 09:32:24 0001 1100 0000 0000
05/07/6002 09:32:20 0000 1100 0000 0000
05/07/6002 09:31:00 0001 1100 0000 0000
05/07/6002 09:30:34 0000 1100 0000 0000
05/07/6002 09:28:44 0001 1100 0000 0000

```

---





To see how many index entries you have you can press the DATA SETUP button located in the lower left corner of General Setup window. The Event Index is the number of records currently stored. The maximum number of records that can be stored is 4,500. When all 4,500 records have been used the oldest recorded entries will start to be over written. On a very active controller the last 7 – 10 days will be indexed. The amount of days recorded depends on how often relays or going on and off.

### Graphing the Event Index

The most powerful usage of the event index comes when you graph is against the sensor data index. This can be done with the AcuGraph software package. When you graph events against sensor data you can actually see trends and control in action. In the below graphs you can see two sanitizer relays label Chlor (Chlorinator) and B/U (Backup) come on when ORP1 level drops.

## Sensor Setup

The Controller will allow the operator to determine which sensor measurements are displayed when viewing the data in the System and Summary Display Screens. To access the Sensor Setup menu, touch the SENSORS button, located in the lower left corner of Data Setup screen.

MODULE	Sensor Setup			XX
Measurement	M1	M2	M3	
PH	<input type="checkbox"/>	<input type="checkbox"/>	<input type="checkbox"/>	
ORP	<input type="checkbox"/>	<input type="checkbox"/>	<input type="checkbox"/>	
PPM	<input type="checkbox"/>	<input type="checkbox"/>	<input type="checkbox"/>	
Temp	<input type="checkbox"/>	<input type="checkbox"/>	<input type="checkbox"/>	
Cond	<input type="checkbox"/>	<input type="checkbox"/>	<input type="checkbox"/>	
Cond	<input type="checkbox"/>	<input type="checkbox"/>	<input type="checkbox"/>	
Plow	<input type="checkbox"/>	<input type="checkbox"/>	<input type="checkbox"/>	
Phigh	<input type="checkbox"/>	<input type="checkbox"/>	<input type="checkbox"/>	
<input type="button" value="Toggle"/>	<input type="button" value="Toggle"/>			<input type="button" value="CHANGE"/>



Sensor Setup menu

The Sensor Setup menu contains a list of all possible sensors that could possibly be measured by each installed sensor module. The main sensor list contains pH, ORP, PPM, Temp, Cond, Flo1, Plow (Pressure Low), and Phigh (Pressure High). There are more possible sensors than are listed in this screen. To view these additional choices, use the toggle buttons on the lower left hand side of the screen. The first TOGGLE button will scroll through choices on the fifth line; the sensor choices available in this second menu include Flo1, Flo2, Tot1, TOT2, CPPM, and TPPM. The second TOGGLE button will scroll through choices on the sixth line; the sensor choices available in this third menu are Flo1, Flo2, Tot1, Tot2, CPPM, TPPM, and Cond. An X will appear in each box under the Module header to show which measured functions are being displayed for that module board.

It is possible to select the sensor readings that will be displayed when viewing the data for each module. Use the directional arrows to highlight the sensor checkbox for each module. Once highlighted, touching the CHANGE button in the lower right hand of screen selects, or unselects, the sensor box highlighted for each module. The selections have no effect on the data being recorded, only the data to be displayed.

## The System Menu

The System menu is one of the most important menus in the Controller. This menu is the gateway to all the menus and settings for the controller system itself, the hardware, the security settings, and the sensor module assignments. The System menu is a very large submenu and contains multiple sub-menus, as well as important system settings. The following sections will explain each of these submenus in detail.

System Menu		XX
Time	: 11:14:00	
Date	: 05/30/06	
Weekday	: Monday	
Units	: English	
HOA	: Enabled	
Program Mode	: Easy	
Serial #	: 10000	
<input type="button" value="HARDWARE"/>	<input type="button" value="DISPLAY"/>	<input type="button" value="PRINT"/>
<input type="button" value="SECURITY"/>	<input type="button" value="Reset Menu"/>	<input type="button" value="CHANGE"/>

System Menu

One of your first steps to set up an Controller will be to set the Time, Date, Weekday, Units, and Mode. These are set at the factory, but may need to be entered or changed. The time, date, day, and units are critical components to most of the programs that will be run by the Controller. In order for the controller to function correctly, these values must be correct. These settings are important for calculating correct readings and troubleshooting.

### Time

The current time of day is displayed here. The Controller uses a 24 hour clock. Times will range from 00:00:00 (12:00 a.m.) to 23:59:59 (11:59 p.m.)

To change the current time, Use the directional arrows to highlight the settings. Then press the CHANGE button to select the item. The alphanumeric keyboard will automatically launch and prompt you to enter a value. Once the value has been entered, press the ENTER button to save your changes.

### Date

The current date is displayed here. The date can be displayed in either metric or English units. If metric is selected the date is entered as dd/mm/yr, for English units the date is entered as mm/dd/yr.

To change the current date, use the directional arrows to highlight the settings. Then press the CHANGE button to select the item. The alphanumeric keyboard will automatically launch and prompt you to enter a value. Once the value has been entered, press the ENTER button to save your changes.

## Weekday

The current day of the week is displayed here. To change the current day of the week, use the directional arrows to highlight the settings. Use the change button to scroll through the selections, which includes Monday through Sunday. Once you have reached the appropriate day, exit the selected item using the up and down arrow buttons.

## Units

The Controller can display measurements in Metric or English units. To select one of these measurement systems, use the directional arrows to highlight the settings. Use the change button to toggle between the two measurement systems.

## Program Mode

(Version D6 and Higher)

The Controller will allow the user to select between Easy and Advanced programming modes. When set to Advanced the ability to change and add commands as well as the sequencing capability of the Controller are enabled. When in easy programming mode only the values of a command can be changed.

### **CAUTION**

When editing an MPS, if sequences other than 1 are used the MPS will default to advanced programming. If an MPS is contained in advanced programming, its associated values can be edited at any time in easy programming, so long as only sequence 1 is used.

## HOA

The Controller can operate solely on the programming provided by the operator. However, it can also be configured to allow the operator to change easily between manual operation, having certain relays off altogether, and allowing the programming to manage the controller. This configuration is called HOA mode. When HOA mode is enabled, a button in the MPS screen will allow the user to easily turn relays off and on manually, turn individual relays off completely, and to allow the controller programming to operate the relay.

To select one of these measurement systems, use the directional arrows to highlight the settings. Use the change button to toggle between the two measurement systems. For more information on working with relays with HOA enabled, please see p.80.

## Serial Number

The serial number can be viewed here. The serial number is a unique identification number for your Controller. It can not be changed.



## The System Menu Sub Menus



The System Menu contains a number of sub-menus that are accessed through buttons on the system menu screen. These sub-menus include: HARDWARE, DISPLAY, PRINT, SECURITY, and RESET MENU: Each system sub-menu contains a group of like items, dealing with the overall function of the system.

### Hardware Configuration

The Hardware Configuration sub-menu is used when the sensor modules in the Controller are expanded or changed. To open the Hardware Configuration menu, touch the HARDWARE button, in the System menu.

The Hardware Configuration menu contains a list of each installed sensor module. This list is organized by the number of the module slot the sensor module is installed in. The Controller will display the sensor module number, as well as the sensors supported by that module.

The modem, serial port and the external ram are automatically detected and selected, not user selected, and their status is displayed here.

Hardware Configuration		XX
Module 1	: AK610, pH, ORP, T	
Module 2	: AK613, pH, ORP, T, Cond	
Module 3	: Empty	
RS232 Type	: PC	
Relay Type	: 8 Relay Type	
High Speed Modem	: MT5600	
UART(RS485+Printer)	: EMPTY	
512K RAM Expansion	: Empty	
		<input type="button" value="CHANGE"/>

Hardware Configuration Screen

To navigate the Hardware Configuration Menu, use directional arrows to highlight the sensor module you wish to change.

Once you have selected the sensor module, touch the CHANGE button to toggle through the following sensor module options: Empty, AK610, AK612, AK614, AK615, AK616, and AK617. The correct sensor module numbers must be selected for the Controller to measure correctly. Your Controller will automatically be configured at the factory with the correct sensor modules. This step will only be necessary if you uninstall or change the original sensor modules.

After selecting the correct sensor module for each of the three modules, touch the x in the upper right hand corner to return to the System Menu. Your new entry will automatically be saved by the controller. The controller will then ask you; "Do you want to reset the associated 4 relays to the factory defaults for Module 1, 2 or 3?" If you press "Y" the programming of the relays will change to the default programming for that type of sensor module. Pressing "N" will not make any changes to the current programming.

### CAUTION

The AK612 pressure sensor can only be installed in module three (M3).

The hardware configuration menu is also used to select the communication method being used by the controller. The RS232 Type menu option is used to enable the wireless modem or the RS232 connection on the motherboard. the PC option enables the RS232 connection or the dial pu modem, while the internet option enables the wireless modem.



In addition, the hardware configuration menu is used to select the type of relay board being used by your Controller. This menu item allows previous versions of the Controller or AK200 controller to work with the current Controller design. If you are using a new controller, please set this to 8 relay type, no matter how many relays are installed. If you are using an older version of the rley board, contact your Acu-Trol dealer for assistance.



## Display

The DISPLAY submenu is used to display the order that information from each sensor is displayed in the SUMMARY and SPECIFIC display screens. It is also the gateway used to change the order that the information from each sensor is displayed in. The Display menu is opened by pressing the DISPLAY button in the SYSTEM menu.

Use the directional arrows to scroll within the display menu. The current item will be highlighted. Once you have reached the item you wish to edit, press the CHANGE button. This will open the Display Setup screen, where the list of measurements and relay number can be assigned.

#	RLY MEAS	RLY MEAS	RLY MEAS	XX
1.	1 pH1	5 pH2	0 pH3	
2.	2 ORP1	6 ORP2	0 ORP3	
3.	0	0	0	
4.	4 Temp1	8 Temp2	0 Temp3	
5.	0	0	0	
6.	0	0	0	
7.	0	0	0	
8.	0	0	0	
9.	0	0	0	

CHANGE

Display Screen

## Display Setup

The Display Setup screen opens the list of measurements that can be displayed. This screen will enable you to select which measurement will be displayed on a specific line. It also will enable the user to select the relay that will be controlling that measurement. When you install a new sensor card in the controller, the factory default settings for that card will be automatically updated and displayed here.

Navigate the screen by using directional arrows to move the arrow to the desired measurement or condition for each line. It is also possible to select a specific relay to associate with a specific measurement by touching the relay number to the left and then entering the measurement you wish to associate with that relay. The process needs to be repeated for each relay and measurement

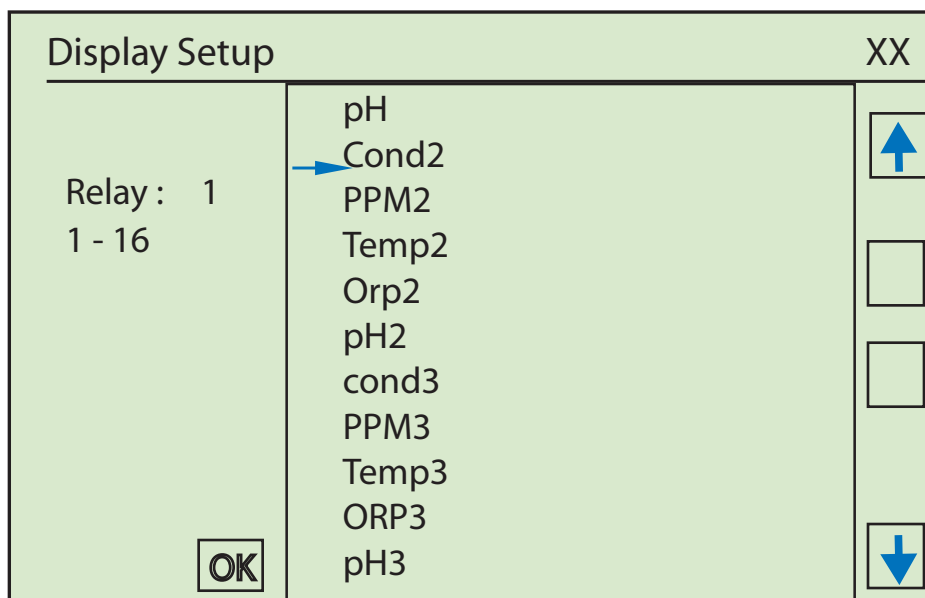

Display Setup Menu

The Display Setup menu contains all of the available sensors. An overview of each of these measurements, and their requirements are listed below.



- Cond1, 2, 3: Conductivity measurements monitor the mineral content of the water. These measurements range from 0 to 9999 uS. When using conductivity sensors the TDS and NACL concentrations can also be calculated by the Controller, described in the Calibrating Conductivity section. The Controller can monitor up to three conductivity sensors. Enabling conductivity on an Controller requires an AK613 or AK614 sensor module.
- FI1, 2, 3, 4, 5, 6: Digital flow inputs monitor the rate of flow of the water in the system. These inputs should be connected to digital flow meters only. The output is displayed in gallons per minute (gpm) or liters per minute (lpm) depending on the units selected by the operator. A specific sensor module is not required to monitor digital flow meters. Digital flow meters do not have a default configuration, and will need to be configured manually.

- Lan1, 2, 3: The Langlier saturation index is an indication of the waters tendency to be scaling, corrosive or balanced. The controller will use current measurements along with the alkalinity, Total dissolved solids (TDS) and hardness input by the operator. If a conductivity sensor is in use the TDS used in the calculation will be the measured TDS from the sensor.
- ORP1, 2, 3: ORP is the oxidation reduction potential measurement of the water. This measurement is used to control the sanitizer and in the calculation of the displayed PPM measurement.
- Temp1, 2, 3: The temperature inputs require the AK10K negative coefficient thermistor.
- P1H, P2H: Pressure High is used to identify the high pressure input for the differential pressure sensor. An AK612 pressure card is required to read both high and low pressures.
- P1L, P2L: Pressure, low is used to identify the low pressure input for the differential pressure sensor. An AK612 pressure card is required to read both high and low pressures.
- PPM1, 2, 3: The Controller can use the AK610 sensor card to display a calculated PPM reading. The Controller can also measure Colormetric PPM using the AK615 and AK616 sensor modules and an AKColor.
- pH 1, 2, 3: The pH of the water in your system is very important for pool maintenance. The Controller will monitor the pH of your water using any of the available sensor modules. The pH input uses temperature compensation for increased accuracy.
- TPPM 1, 2, 3: There are two types of chlorine in your system: free chlorine which is available for sanitization, and combined chlorine, which has combined with other molecules in the water and is no longer able to sanitize. The total chlorine measurement will tell you how much total chlorine you have in your system using an AKCOLOR TOTAL and an AK615 or AK616 sensor module.
- CPPM 1, 2, 3: There are two types of chlorine in your system: free chlorine which is available for sanitization, and combined chlorine, which has combined with other molecules in the water and is no longer able to sanitize. The combined chlorine measurement will tell you how much unavailable chlorine you have in your system using an AKCOLOR TOTAL and an AK615 or AK616 sensor module. Combined chlorine measurement from an AKCOLOR TOTAL.

## Printer Setup

To open the Printer Setup screen, touch the PRINT button, in the System Menu. The Printer Setup screen contains the controls for the Communication module that will allow you to print your stored data from the Controller with a serial printer.

There are two methods of communicating with serial printers. One uses an RS232 cable to connect directly to the motherboard of the Controller. The other method uses the serial connections on the communication board to connect a serial printer directly to the Controller. Both methods expand the ability of Controller to allow the operator to print data lines, the controller setup, and the saved data.

Printer Setup		XX
Moterhboard RS232	PC	
Print time Interval	01:00:00	
Printer Type	Wide	
If Modem Board Installed		
Printer assigned to the Modem RS232.		
Changing the Motehrboard RS232		
disables communications with the PC.		
<input type="button" value="Send Setup to Printer"/>		
<input type="button" value="Send Data to Printer"/>		<input type="button" value="CHANGE"/>

Printer Setup Screen



RS232 method: The first method uses the RS232 connector on the motherboard. An RS232 cable is used to connect directly to a printer. When the RS232 connection is used for a printer, it disables the ability to communicate with a PC using the motherboard RS232 connector. The Motherboard RS232 setting on the Printer Setup Screen controls the port setup for the RS232 connection. Pressing the CHANGE button will allow you to switch between printer and PC communication.

The second method uses the serial connections on the communication board, which adds an additional serial port, dedicated for serial printers. Once the printer communication board (AK633) is installed, two additional buttons will appear on the Printer setup screen. This method allows data to be manually sent to the printer.

To prepare to print, press the Send Setup to Printer: This will send the setup file to the printer. To print, press the Send Data to Printer button to send the data file to the printer. The printing can be aborted at any time by touching the top line when printing.

## Security

One of the most important features of the Controller is the multiple levels of password security that are available for your use. To access the Main Security Setup Screen, press the SECURITY button, located in the System Menu. This screen is used to set passwords, and enable and manage different security levels. Your Controller will be shipped to you without any security passwords.

Main Security Setup		XX
Master	:	
Operator	:	
Operator	:	
Operator	:	
Service	:	
Service	:	
Service	:	
CLEAR ALL	:	select
		<input type="button" value="CHANGE"/>

Security Screen

The security system in the Controller has four (4) security levels. Each security level will have its own password. Each security level allows a different level of access. The Controller will allow you to set one master password, three passwords at the operator access level, and three passwords at the service access level. A password protected controller will allow any user to view the display menu screen without entering a password. It is strongly suggested that you assign each technician or operator their own password. This will allow you to monitor when the controller is viewed or modified, and by whom.

**SERVICE:** A service level password will provide the most limited access to the Controller. A password at this

level will allow the user to access the standard functions used to service the Controller and the body of water. A service password will allow the holder to view the current readings, as well as calibrate or manually turn on relays; any changes in the programming are blocked. There are three passwords at this security level.

**OPERATOR:** An operator level password allows viewing and modification of most of the settings in the Controller. The operator security level will allow the user to access all areas of the controller, with

the exception of the security setup menus. An individual with operator level access will be able to service the controller, as well as make changes to the programming and calibration data stored by the Controller. There are three (3) passwords at this security level.

**MASTER:** The master password allows the highest level of security clearance. The master password will allow the user to access and modify every screen and command in the Controller, including the creation and management of passwords. A master password must be entered in to the controller before any other levels of passwords are created. Operator and service level passwords will not be able to be assigned if there is no master password. There is only one master password per controller. On any Controller with password protection, the security level of the password currently in use will be displayed in the upper right corner of the Main Menu screen. The Controller will record the security level and the password in use in the data log, along with the current measurements and relay conditions. This information will tell the supervisor who accessed the controller and at what time.

#### Security Level Summary

LEVEL	#	Description
MASTER	1	Access to all screens including Security.
OPERATOR	2	Access to all screens except Security.
OPERATOR	3	
OPERATOR	4	
SERVICE	5	Access to all items in the Display and Service menu only except for global disable.
SERVICE	6	
SERVICE	7	

To enable the advanced menu with the voice modem a password is required. When the password is entered it must match the first four numbers of one of the passwords in the security menu. In addition, only numbers are allowed. A valid password would be “1234abcd”, then to access the advanced menu press 1,2,3,4 on the touch tones on the phone. Invalid passwords include: “123”, 12a34, and 1two.

The Controller also provides an additional layer of security by allowing an on site operator to activate a communication lockout. This will prevent anyone from viewing or modifying the controller and its programming with a modem or other communication device.

To activate the communication lockout mode you will need to make some adjustments to the Sync Bytes in your Controller and your AcuCOM software package. Sync Bytes provide a secondary form of security. The Controller and the AcuCOM software package both contain Sync Bytes. To communicate with a controller the sync bytes in the communication software and the sync bytes in the controller must match. Every controller with a modem is shipped with a corresponding version of AcuCOM software. If you wish to limit access to your Controller so that only a few individuals or computers can communicate with it; you will need to change the sync byte values in the Controller and in the AcuCOM software. For assistance with this, please contact your local

**NOTE**

When a password has been entered to allow access, it will be reset when the backlight turns off.

**NOTE**



The password can use upper and lower case characters in addition to numbers and symbols.

**NOTE**

When the wireless modem is being used any password must be entered and security must be enabled or direct communication "WILL NOT BE ALLOWED." This is one of the main security features of the wireless.

### Entering a Password

Selecting a password and using the multiple security levels available in the Controller will help you to protect your system, your patrons and your investment. Multiple security level passwords should be selected as soon as the controller is installed.

Main Security Setup		XX
Master	:	
Operator	:	
Operator	:	
Operator	:	
Service	:	
Service	:	
Service	:	
CLEAR ALL	: select	
		<input type="button" value="CHANGE"/>

### Security Screen



To enter a password, use the directional arrows to highlight the desired level and touch the CHANGE button with your stylus. The alpha numeric keyboard will automatically open. Each password may be up to ten (10) characters. You may use any combination of the characters available in the Controller's alphanumeric keyboard. Once you have selected your password, touch the OK button to save your password and close the alphanumeric keyboard.

To clear all of the passwords, use the directional arrows to highlight the CLEAR ALL command. Press the CHANGE button with your stylus to clear the current passwords. If you forget the Master password, you will need to contact your dealer for assistance.

## Reset Menu

The Controller saves the factory default programming in its memory. As you are using and programming your controller, you may want or need to reactivate these factory default settings. The Reset Menu will enable the operator to restore some or all of these factory default settings. The Reset Menu also allows the operator to clear alterations made by the operator to the function of the controller, such as clearing any sensor calibrations or resetting the hardware configuration.

The Reset Menu is one of the many sub-menus of the SYSTEM menu. To access the Reset Menu, use your stylus to press the RESET MENU button in the SYSTEM menu screen.

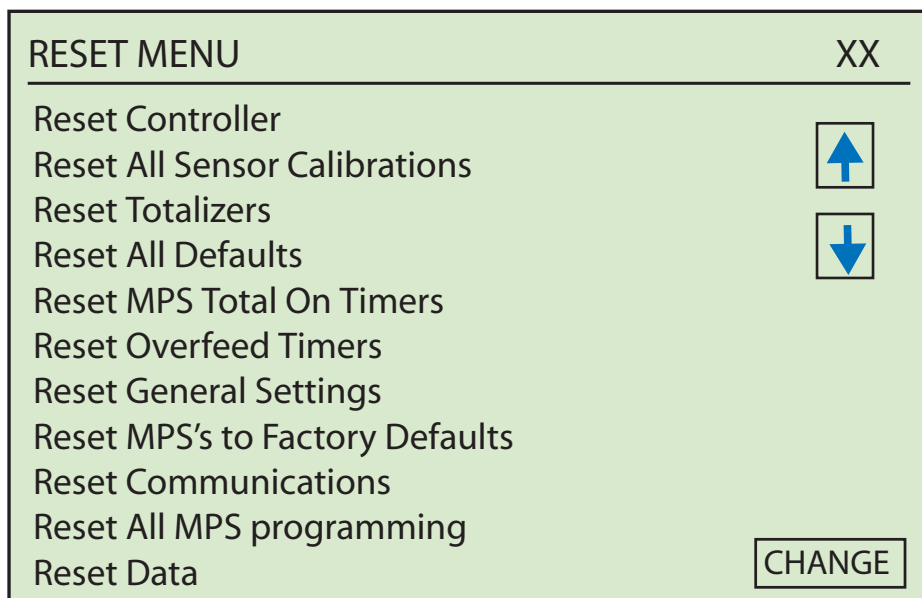

The RESET MENU contains multiple menu items. Each menu item allows the user to reactivate some or all of the factory default settings for the Controller.

- Reset Controller: This command has the same affect as turning the Controller OFF and ON without actually cycling power.
- Reset All Sensor Calibrations: This command clears all sensor calibrations, with the exception of any installed flow meters. Once these calibrations have been cleared, each individual sensor will need to be re-calibrated in the calibration screen.

- **Reset Totalizers:** This command clears the accumulated volume measurements for all flow meters.
- **Reset Configuration:** This command clears the hardware sensor modules and leaves the programming intact. It is highly recommended that you do not use this setting without assistance from your dealer.
- **Reset MPS Total ON Timers:** Clears the cumulative MPS relay timers for all relays. Clearing these timers will allow you to monitor how long any one relay is on over a certain period of time. Total On Timers are not reset when the overfeed timers clear.
- **Reset Overfeed Timers:** Clears the daily MPS timers for all relays. This command is especially useful when you have reached your feed time limit and your Controller is in overfeed on one or more relays.
- **Reset General Settings:** This command sets the general settings to the factory defaults. The general settings on the Controller include the alarm parameters, the sensor set-up, and the organization of the data log.
- **Reset MPS to Factory Default:** This action sets all relay configurations (MPS) to the factory default settings and deletes all previous programming. It is important to specify the Hardware Set-up from the System screen before performing this reset.
- **Reset Communications:** This command resets the user programmed communication options to factory default settings.
- **Reset All MPS Programming:** This command clears all relay (MPS) programming.
- **Reset Data:** Clears all Normal data, Event Data, and Relay On Time records

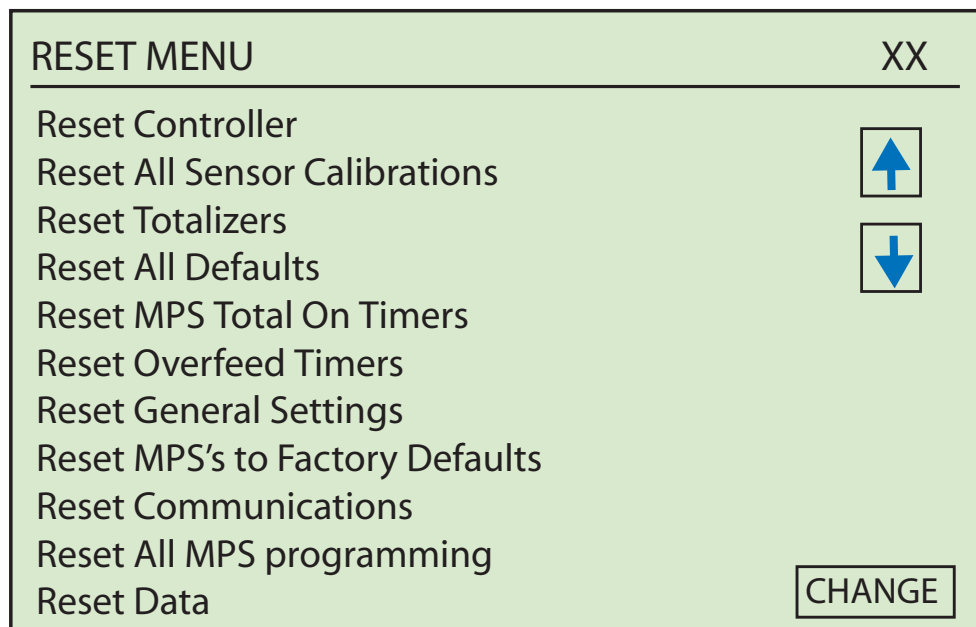

To activate one of the reset commands, Use the directional arrows to highlight the appropriate command for the items you wish to reset and touch the CHANGE button. The controller will ask “Are you sure: Y or N”. Press the Y button to reset the selected settings. Press the N button if you do not wish to reset the selected settings at this time. Once you have confirmed your choice, The Reset Menu will stay open for any more changes you wish to make.

Touching the “--more--” command at the top of the screen will open a second reset menu with the following options.

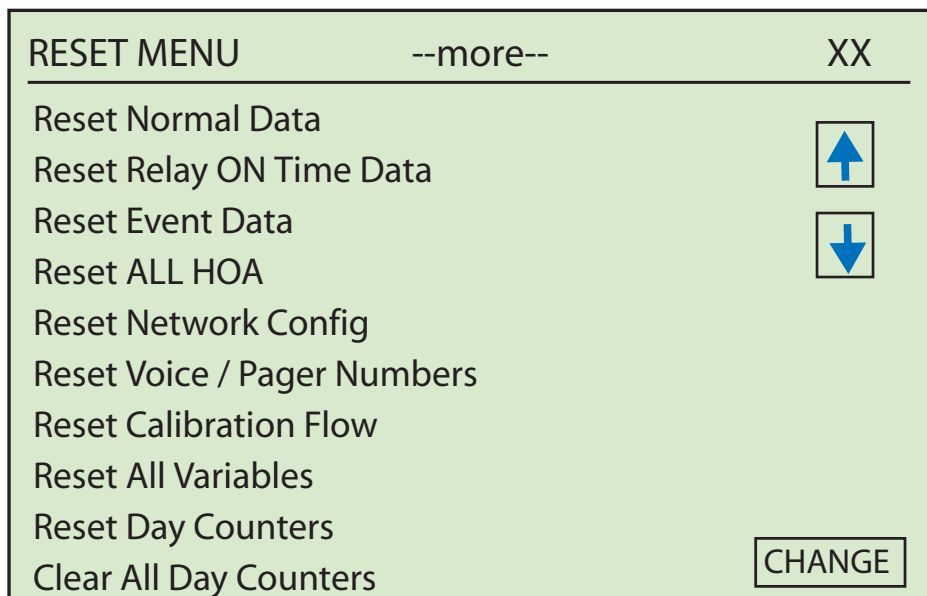

(more) Reset Menu Screen

- Reset Normal Data: This command clears just the normal data records in the data log.
- Reset Relay ON Time Data: This command clears the cumulative timers for only the Relay ON Time.
- Reset Event Data: This command clears just the event data records from the data log.
- Reset All HOA: This command Sets HOA setting to “Automatic on ALL relays when the HOA function has been turned on.
- Reset Network Config: This command clears all of the user programmed RS485 Network settings.
- Reset Voice/Pager Numbers: Clears all Pager, Voice, and Email entries.
- Reset Calibration Flow: Resets all Flow calibrations to defaults.
- Reset All Variables: Resets the Controller to the factory deefault settings.
- Reset Day Counters: Not Used
- Clear All Day Counters: Not Used.

## Section 9 Programming

The Controller has an easy programming interface which allows the operator to modify the timing, set points, and other operating parameters and variables that are a part of the standard factory programs or wizards. These wizards have been optimized to work with your Controller. Mini Programs are used to control all the relays in the Controller. These mini programs tell the controller which relay to turn on, when to turn them on, how long they should stay on for, and how long to wait before turning on again. They can also tell the controller to page or call a specific technician when a specific condition occurs.

To enable these programs to work on any system and with any device, any relay or MPS in the AK 600 can be programmed using a wizard and then modified to suit the system being controlled. The Controller uses up to forty-four (44) Mini Programs (MPS) to determine which relays, alarms and pagers should be ON or OFF. Each relay in the Controller can be operated with any one of the 44 mini programs. Relays in the Controller are configured at the factory to accept any of the mini programs and function with the selected program.

In rare cases one of the many available wizards will not meet the needs of your application. In these situations a custom program may be able to be written for your specific application. Please feel free to

### MPS Modules

Programming your Controller to operate one or multiple devices is done in the Select MPS module screen. The Controller contains 16 physical relays and 8 soft relays. Physical relays are used to control the devices in your pool room. Soft relays are used to expand the programming of the 16 physical relays.

Select MPS Module	XX			
Relays	1 - 4	5 - 8	9 - 12	13 - 16
Soft	1 - 4	5 - 8		
Alarms	1 - 4			
PVE	1 - 4	5 - 8		
	9 - 12	13 - 16		

The relays in the Controller are organized in to five distinct groups. The physical, or R relays are used to control physical devices attached to your controller. Soft relays, or S relays are used to run operations where more than one device is involved. Alarm or A relays are used to turn on an alarm condition when user specified conditions are met. Pager/Voice/Email relays, or PVE relays are used by the Controller to communicate with a pager, voice line, or email account.

To open the Select MPS module screen, use your stylus to open the CONFIG menu and then the Programming sub-menu. Once you have done this, the Select MPS Module screen will open. All the MPS relays are numbered and are viewed in groups of four on the display screen. To configure a specific relay, touch the number of its group directly on the screen.

### Select MPS to Configure

The Select MPS to Configure screen opens the specific group of four relay modules and their status. This screen will allow you to perform two functions: access and change the programming wizard controlling the relay and change the function of the relay.

Select MPS Module to Configure			XX
RLY01	<input type="checkbox"/>	pH - Acid	M1 <input type="button" value="WIZ"/>
RLY02	<input type="checkbox"/>	Sanitizer	M1 <input type="button" value="WIZ"/>
RLY03	<input type="checkbox"/>	Empty	<input type="button" value="WIZ"/>
RLY04	<input type="checkbox"/>	Temp	M1 <input type="button" value="WIZ"/>
<input type="button" value="PREV 4"/>		<input type="button" value="OK"/>	<input type="button" value="NEXT 4"/>

Select MPS to Configure Screen

You may scroll through all of the Relays in the Controller using the NEXT 4 or PREV 4 buttons on the bottom of the screen. Once you have finished in this screen, press the OK button to exit from this screen.

To change which device the relay is controlling, you will need to open the Select New Configuration Screen. To do this, press the WIZ button on the same line as the MPS you wish to configure. The Select New Configuration screen will automatically be opened.

## Select New Configuration

The Select New Configuration screen allows you to select the type of device you wish to control with the MPS relay you have selected

Select New Configuration		XX
PRESSING OK RESETS ALL COMMANDS AND TIMERS FOR THIS MPS!!!  MODULE 1 <input type="checkbox"/> 2 <input type="checkbox"/> 3 <input type="checkbox"/>  <input type="button" value="CANCEL"/> <input type="button" value="OK"/>	Empty	<input type="button" value="↑"/>
	Sanitizer	
	Sanitizer/Super	
	pH - Acid	<input type="checkbox"/>
	pH - Base	
	Heater	<input type="checkbox"/>
	Circ / Pump Basic	
	→ De - Chlor	
	Alarm	
	Pager/ Voice	
Backwash Start	<input type="button" value="↓"/>	



All of the configuration options for the MPS you have selected are in a list on the right hand side of the screen. The arrow shows the configuration option that is currently highlighted for selection. Use the directional arrows to move this cursor arrow to the control type you wish to set for the selected MPS relay. Once you have selected the appropriate device, press the OK button. IF you do not wish to change your previous programming at this time, press the CANCEL button.



To access additional commands press the  on the left side of screen to scroll up or down one page at a time.

### CAUTION

Sensor Modules must be selected in the Select New Configuration Screen to ensure that the MPS is programmed correctly.

## Modifying MPS Settings Screen

Select the MPS that is to be changed in the Select MPS to Configure screen. The following screen, Modifying MPS Settings will open. In this detailed command screen, you can scroll through the commands for your selected MPS using the up and down arrows  .

PH - Acid		XX
<hr/>		
SequencesON		
Manual ON Time	00:01:00	
Prop GON %	10	
On if pH >	7.50	
Max Time On	00:01:00	

Modifying MPS Settings Screen

Press on the value that is to be changed. You may edit the name of the MPS by pressing on the top line of the Modifying MPS settings Screen. You will be taken to the editing screen, where you can change the name. The name can be up to 20 characters long. If you wish to disable relays while making changes to the programming, please use the Global Disable command in the service menu.

## The Wiz Button

MPS Wizards offer various types of programming which are known and optimized. The wizard inserts a complete program for the MPS module selected and erases the original programming. Please see the Appendix for a list of MPS Wizard programs and descriptions.

To configure an individual MPS, follow the instructions below:

1. Begin by touching CONFIG then Programming.
2. Touch an appropriate MPS grouping from the Select MPS Module screen.
3. After selecting the MPS module group, the MPS Module to Configure screen opens the list of modules for individual selection. Press the WIZ button to enter the wizard selection screen.

## Alarm Configuration



The Controller is designed to allow the operator to have full control over the programming of alarms. The typical alarm assignments are as follows:

ALARM	LED	Pager/Voice
Alarm 1	Sensor Module 1	Yes
Alarm 2	Sensor Module 2	Yes
Alarm 3	Sensor Module 3	Yes
Alarm 4		Yes

The alarms are programmed the same as any MPS. There will be commands that check for out of range measurements and an alarm ON delay, so the alarm condition must exist for a period of time before the alarm activates.

### Automatic Set Point Alarms

The global alarm percentage is the most basic alarm condition in the Controller. The user sets the global alarm percentage. The Controller monitors the chemical measurements, and then compares them to the set point. The global alarm percentage is used to calculate an acceptable operating range for the chemicals in the body of water. The acceptable operating range is the global alarm % above and below the set point. If any of the chemical measurements are outside of this acceptable operating range, the Controller will activate the LED alarm on its front panel.

General Setup		XX
Global Alarm %	: 10	
Global Alarm Delay	00:00:00	
Overfeed Clear Time 1	08:00:00	
Overfeed Clear Time 2	08:00:00	
POver On Delay	:	
Module 1 Name	:	
Module 2 Name	:	
Module 3 Name	:	
Backlight Time Seconds	:00:00:30	
DFL1 Backlight	None	
<input type="button" value="Data Setup"/>		<input type="button" value="CHANGE"/>



---

The Global Alarm % is measured in percentage units. The factory default global alarm % is 10%. To change the global alarm percentage, highlight the item using the up and down arrow buttons. Once highlighted, press the CHANGE button. The alphanumeric keyboard will automatically appear and allow you to enter a new global alarm percentage. Once you are done entering the new global alarm percentage, press the ENTER button to save your changes.

The global alarm % does have some limitations. If you wish to have a different acceptable operating parameter for each sensor, you will need to set each alarm separately. If most of the acceptable operating parameters you wish to set are the same, set the global alarm percentage, and turn off the alarm percentage using “Disable Alarm %”, as the last command on the MPS associated with the sensors you wish to set a different operating range for. You will then need to program the alarms for that MPS manually. To totally disable the global alarm percentage in your Controller, set the alarm percentage to zero.

When the set point alarm is ON a lower case “a” will appear next to the MPS status. The set point alarm will not turn ON the existing alarms one through four (1-4), only the “a” will appear.

To have an alarm turn ON, add the command “ON If SET ALARM” for each MPS, on the appropriate alarm. If a set point alarm is active, the specific display will show “ON If SET ALRM 5” for relay 5 instead of the actual measurement. Note: The only way to get the lower case “a” to appear is to use the alarm percentage feature. A benefit of this feature is if the set points are changed, the alarm band will be automatically adjusted, reducing programming.



### Pager/Voice/Email Alarms

The pager and voice programming will typically have commands that turn ON. It’s possible to have the pagers programmed with tighter tolerances than the normal alarms, so that the Service Company gets a page before the alarm actually turns ON. The SPECIFIC screen will display up to two (2) alarms that are active for each module. The last two lines on the display will switch from measurement data (if programmed to) to alarm information, if the alarm is on. Only two (2) alarms will display, even if there are more active.

## Communication

The ability to communicate is one of the most useful and beneficial features of the Controller. While modems are optional equipment we strongly recommend that you consider a modem when making your purchase. Modems are especially useful because they enable an operator to monitor and maintain the water balance and to operate the controller from any computer with the AcuCOM software package.

The Communication Menu contains important information that tells your Controller how you wish it to communicate. You will need to tell the controller what ring to pick up on, how long to wait before picking up again, and who to communicate with before you will be able to use the remote communication features of the Controller. To enter each of the following values, use directional arrows to highlight each item.

Communications Setup	--more--	XX
Rings to Answer On	:1	
Long Hangup Time	00:30:00	
Sync Byte 1:	0	
Sync Byte 2:	0	
Voice Code:	0	
	<input type="button" value="PVE"/>	<input type="button" value="VOICE"/>
	<input type="button" value="PVE"/>	<input type="button" value="CHANGE"/>

Communications Setup Screen

**Rings to answer on:** The number of rings the controller will allow before it will answer the call. The number of rings can range from one to nine (1-9). The number 0 will tell the controller not to answer any calls.

**Long Hang-up Time:** The AcuCOM software used to communicate with your Controller has two different hang up commands. The standard hang up releases the line immediately and instructs the Controller to pick up the next incoming call. The long hang up instructs the controller to not pick up any incoming calls for a certain period of time. This allows the operator to set up multiple controllers on the same phone line. The default long hang-up time in the Controller is 30 minutes. This generally will provide enough time for you to view other controllers sharing the same phone line, without locking you out of any controller for an extended period of time. The more controllers there are sharing a phone line, the longer your long hang-up time will need to be.

**Sync Bytes:** Sync Bytes provide a secondary form of security. The Controller and the AcuCOM software package both contain Sync Bytes. To communicate with a controller the sync bytes in the software and the sync bytes in the controller must match. Every controller with a modem is shipped with a corresponding version of AcuCOM software. If you wish to limit access to your Controller so that only a few individuals or computers can communicate with it; you will need to change the sync byte values in the Controller and in the AcuCOM software. For assistance with this, please contact your local Acu-Trol dealer, or Acu-Trol technical support.

Voice Code: When using the voice mode the controller will identify itself with the serial number if this code is zero (0). If you wish the controller to identify itself with another type of numeric identity code, enter this code as the voice code. The controller will identify itself with the numeric code you have entered in this slot.

VOICE, PAGER #'S and PAGER TEST: All screen buttons are explained and described in the following pages. The Voice button is only available when the Controller memory module is installed.

To open the Modem Advanced Diagnostics sub-menu, select the `–more–` displayed at the top of the Communications set-up screen. You may be asked for information from this screen if you contact the Acu-Trol Service Center. There is no changeable information on this screen except for the modem reset button in the lower left hand portion of the touch screen.

Modem Advanced Diagnostics		XX	
Status:	32	PagDelay :	0
Timer :	16400	PagNumber:	0
CMD :	0	PagStatus :	0
From Modem :	&KO-SDR = 7S8 = 4 OK AT#		
CLS = 0 OK			
<input type="button" value="Reset"/>			

Modem Advanced Diagnostics Screen

Status: Modem status code.

Timer: Modem count – a number that counts down every 200 ms.

CMD: current Controller modem control command in use. 0 means modem is not in use or waiting.

From Modem: Strings being sent to the Controller by the modem.

PagDelay: Delay until the next page in seconds.

PagNumber: Program number doing the paging.

PagStatus: Pagers cued up to be paged. The number is represented in decimal form and must be converted to binary to see which pagers are cued. In the example above you see 129 = 0081 (HEX) = 10000001 (Binary) which is pager #1 and #8 in the cue.

RESET the modem and initialize the modem.

---

## Voice Communication

When the optional Expansion Memory module is installed, the Controller will answer in voice mode when called from a remote phone. The Controller will cycle through the measurements and give the status for each body of water being controlled. Use this window to listen and record all messages.

In order for the voice communication system to work, you will need to complete the following steps:

1. A 4 digit security password will need to be set into the "Config/System/Security" menu before you can access the voice menu options.
2. To use voice activation for an alarm condition you will need to set it up in the "Config/Programming/PVE menu.

To verify that the unit is working properly:

1. Call into the direct dial number assigned to the controller using a touch tone phone.
2. The unit will pick up on the number of rings set in the "Config/Communication Setup" Menu screen.
3. The system will then ask you to press "3" on your touch-tone phone. (If you do not press "3" the system will communicate as if it were communicating with a computer system).
4. Once "3" has been pressed, the system will go into voice mode and instruct you to:
  - 4a. Press "\*" when you are ready for the system to hang up.  
A long hang up is always performed.
  - 4b. The controller will then announce the serial number of the system, or if enabled, the voice code.
  - 4c. Press "0" to change to a different menu.
  - 4d. The system will begin speaking the information that is shown on the "Display/Summary" screen.
  - 4e. This information will be repeated until you choose to go to another menu or hang up.

## Voice Communication Menus

Once you have called into the unit and established voice communication you can press 0 to open up additional areas to control or change some values.

In order to access any of the menu items you will need to input a proper password. While in voice mode, the Controller has only one level of password security. All passwords will have access to the same menus

### Controller Voice Communications Menu

Press #	Function	Action	DTMF
3	Voice Call Established		3
	Greeting w/Serial Number		
3	Cycles through all readings and status of relays		* - Hang Up, 1 - 3 for data on that pool, 0 for the main menu.
4	Menu 1: Status Report	Go to # 3	1
5	Menu 2: MPS On Time	Will voice the MPS status and the feed time for the day	1 -- 44 #, 0 to return to the menu
6	Menu 3: Manual Feed	Enter MPS number, Will continuously voice the status of that MPS, Press # to cycle the on/off status. 0 to exit.	1 -- 44 #, 0 to return to the menu
7	Menu 4: Global Disable	Enter MPS number to disable/enable for 12 hours, will cycle through all MPS that are in GD.	1 -- 44 #, 0 to return to the menu
8	Menu 5: Calibrate pH	Enter module #, then pH without the decimal point	Will cycle/repeat the reading. When done press # to accept, 0 to exit without saving.
9	Menu 6: Calibrate ORP	Enter module #, then ORP without the decimal point.	Will cycle/repeat the reading. When done press # to accept, 0 to exit without saving.
10	Menu 8: Manual Sequence 3	Enter the MPS to enable /disable the manual sequence 3. Note Controller will stay in this mode until the Controller is accessed in non-voice mode.	1 -- 44 #, 0 to return to the menu
11	Menu 9: Manual Sequence 4	Enter the MPS to enable / disable the manual sequence 4. Note the Controller will stay in this mode until the Controller is accessed in a non-voice mode.	1 -- 44 #, 0 to return to the menu
12	Menu #: Help	Will cycle through help messages.	0 to return to menu

If no buttons are pressed on the phone for two (2) minutes, the Controller will automatically hang up.

When listening to the readings, press 1, 2, or 3 to go quickly to that pool. To hear the reading on pool 3 it is not necessary to wait for the first two pools.

## Voice Button

To RECORD or PLAYBACK a manual call must be placed to the Controller while in this menu. If the call is placed to the Controller without being in this window, it will go to data mode or normal voice mode. There are 100 different phrases/words the Controller has recorded and each one must be in the correct index.

Status:	Not Ready	XX
Manually Call the UNIT and be in This menu to record or playback (Statement or value)		
String Time (x100):	291	
Status =	Not Ready	
Seconds Remaining (250 Max)	45	
Word / Phase Index	0	
Record : 3-STOP	PREV 4	PREV
PLAYBACK	NEXT 4	NEXT

Touch the NEXT/PREV or NEXT4/PREV4 to go to the index necessary to record, then touch the RECORD: 3-STOP button.

Speak into the phone to record after the status switches to record and touch three (3) when done. The three (3) button on the phone must be held down in order to stop the recording when finished. Touch PLAYBACK button to listen to the recording. Repeat for all the phrases.

(Statement or Value): Press 3 to enter voice mode: Phrase index 0, by touching PREV the index will go to the next one.

String Time: The string time for the first phrase is 2.54 seconds. The times will vary according to personal messages. The length of time does not matter, so long as the total is less than 250 seconds.

STATUS: Ready or Not Ready will be indicated.

Seconds Remaining: Each string time will vary according messages, maximum is 250 seconds.

Word/Phrase Index: Numerical listing of the number of words used.

RECORD: 3-STOP: Record button changes status to record. Touch the three (3) button on the phone to stop recording.

PLAYBACK: Playback button to listen to the recording.

### NOTE

The high speed modem MTS5600 is the only modem that supports voice communication with the Controller. If you are unsure which modem your controller has installed, check the "Config/System/hardware" menu for the modem information.

## Voice system Testing

You will want to verify that your Controller has been correctly configured to call out when alarm conditions occur. To verify that the system will call out properly, you will need to verify that the system is able to call out. Check to see that a proper set of numbers are entered into the “Config/Setup/PVE” program. Then select “PVE Test”. The system will dial that number/s and when that phone call is received a voice will tell the individual the serial number of the unit and the current readings.

## PVE

By touching the PVE button on the Communication screen the PVE numbers may be entered. The Controller has the ability to call up to sixteen (16) pagers, voice lines, or emails when an alarm condition or any number of other operator selectable conditions occurs. All information about the page is contained in the dial string entered. Up to twenty-nine (29) digits for each PVE may be entered. The number should include the following.

Select PVE	XX
1. 18001234567 , , , 12345 , , 123#	
2. 18009871234	
3. ralf@skylab.com	
4. AM	
<b>NEXT 4</b>	

Select Pager # Screen

Pagers: First character must not be ‘-‘ and can’t include an ‘@’. Enter the pager number, commas, PIN (if used), more commas, and a code for this Controller.

A typical pager number would look like the number in the screen above. This pager has a pin access code of 12345, and the actual number going to the pager is 1 2 3. Note: The # symbol is not inserted automatically; it must be included in the string. When getting this page, the pager would show the code numbers 1 2 3. The code may be anything and each code should be unique so which controller the page came from is known. The same pager can also use more than one entry by using different conditions to start the page. This can alert to different alarm conditions. Touch NEXT 4 to continue entering the list of pager numbers. If the code is the letter B the serial number will be automatically inserted.

**VOICE:** First character must be '-' and can't include an '@'. Simply enter the phone number to be called, EX: -2345678#.

**EMAIL:** Must be a valid email address including the '@' symbol. The first character can't be '-'.

**ACUMANAGE DATA PACKET:** If the PVE is simply "AM", then if this PVE is activated a data packet will automatically be sent.

The commas are used to create a delay. The standard comma delay is four (4) seconds. Longer delays can be obtained by using more commas.

## Pager Testing

Touching this button will cause the Controller to dial all the pager numbers for a quick pager test. Another way to test the pagers is to use the manual mode. To do this a manual time of two (2) seconds should be added to the programming of the pagers, then select the MPS to be dialed in the manual mode.



# Sectionr 11      Service

The SERVICE MENU contains all of the functions used in the day to day operation of the Controller. All of the commands you will need to perform the daily and weekly service necessary on your pool or spa are contained in this menu. These service activities will help you to provide the best operation and maintenance of your system with the Controller.

Display	Config	Service	XX
		Manual	
		Calibration	
		Global Disable	
		Clear Overfeeds	

Service Menu Screen

Touching the SERVICE menu line in the main menu will open a pull down menu that contains all of the service sub-menu options. These include: Manual, Calibration, Global Disable, and Clear Overfeeds. These sub-menus will allow you to manually turn on and off each relay, calibrate your sensors, turn off multiple relays for a specified period of time, reset the controller or the overfeed timers, and enter a service level password to access the service menu.

## Manual MPS Operation

The Controller will allow you and your service technician to choose whether each relay in the Controller is operated manually, by the programming in the controller, or off completely. This determination is done in the Manual screen. To open this screen, touch the Manual sub-menu item line in the SERVICE pull down menu. The Select MPS Module screen will automatically open.

Select MPS Module	XX			
Relays	1 - 4	5 - 8	9 - 12	13 - 16
Soft	1 - 4	5 - 8		
Alarms	1 - 4			
PVE	1 - 4	5 - 8		
	9 - 12	13 - 16		

You will then need to select the group of relays that the relay you wish to manually operate, turn off, or return to the control of the Controller. To select the desired MPS module grouping, press the appropriate number range in the correct relay category. Once you have done this, the Manually Toggle MPS screen will automatically open. When you select the relay that you want to manually open or close you will be shown the Manually Toggle MPS screen.

Manually Toggle MPS	XX
RLY01 <input type="checkbox"/> pH - Acid	hoA
RLY02 <input type="checkbox"/> Sanitizer	hoA
RLY03 <input type="checkbox"/> Empty	hoA
RLY04 <input type="checkbox"/> Temp	hoA
PREV 4	OK
	NEXT 4

Manually Toggle MPS Screen

To temporarily turn off a relay, touch the box to right of the MPS relay to manually turn the relay ON or OFF. If the MPS relay is currently ON, it will turn OFF. An X will appear in this box to show that this relay is OFF. If the relay has exceeded its daily on time and is now in overfeed, an O will appear in this box. The Hoa buttons to the right of the relays allow the relays to be turned on permanently, disabled permanently, or control of them returned to the Controller. The Controller will come from the factory with all relays in the Automatic mode. To indicate this, the A of the Hoa button will be capitalized.

To change this mode, press the appropriate Hoa button. Pressing this button will toggle through your choices of Hand, Off or Automatic. The first letter of the mode you are currently in will be capitalized. Hand or H mode will keep the relay in its current ON or OFF state. Off or O mode will turn the relay OFF.

This feature can be very useful when working on your pool or spa. For example, if you are working on the sanitizer plumbing, and do not want the sanitizer pump to come ON while you are working, use the Hoa function of your Controller. Press the Hoa button next to the relay controlling the sanitizer until the letter O is capitalized. An “O” will appear next to the ON/OFF indicator box (□) advising that the relay is disabled. This relay will remain disabled until you change the operating mode to either automatic or manual operation, even if the power to the controller is cycled. To put a relay back into service, simply press the Hoa button again. The relay will then be back in automatic mode.

The HOA status of all relays is displayed on the main screen. The “Hoa:” line will list all of the relays in HAND mode. The “hOa:” line lists all of the relays in OFF mode. You can reset all of the relays in HOA modes back to automatic in the RESET/MORE menu.

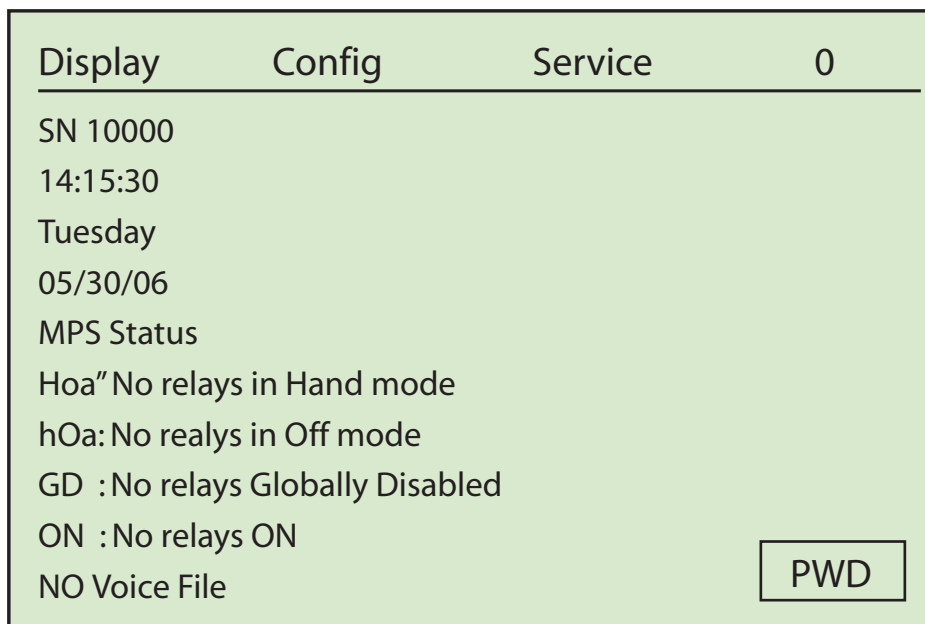

Main Menu Screen

## Calibration

When you first install your Controller the raw reading from each sensor will probably not match up with the values you obtain from your hand tests. The raw sensor reading of each sensor is affected by variances in the manufacturing process and the natural profile of the water in your area. Since every sensor is different, and every water profile is different, it will be necessary to ask the controller to make adjustments to the raw readings of the sensor so that the controller is able to maintain the level of chemicals that your facility needs. This process of aligning the current chemical readings of your system with the raw sensor readings is known as calibration.

To calibrate a sensor, you will need to open the calibration screen. To open the calibration screen, touch the Calibration sub-menu line item while in the SERVICE menu. Once in the Calibration screen, you will be able to open any of the sensors installed on the three sensor modules of the Controller. Open the module number or sensors by directly touching on the name of the desired sensor to open the calibration screen.

Always balance the pool to the desired pH, ORP and PPM levels before calibrating the sensors.

Module	1	2	3	XX
PH		ORP	PPM	T
Flow		Cyn		
Cond		Alk	TDS	Hard

Calibration Screen

### pH Calibration

The pH calibration screen displays the following menu items:

**Point 1:** pH is a single point calibration. You will only need to make one adjustment to align this reading.

**Actual:** The actual sensor reading at the time of the last calibration.

Measure: The last manual pH value entered in the controller.

Current Measurement: The current actual sensor reading.

Before making any adjustments to the calibration of the pH sensor, measure and record the pH using a standard test kit.

If there is a difference of more than a few hundredths between your test kit results and the current controller measurement, you will probably want to calibrate your sensor.

Touch the Reset button to clear any calibrations on this sensor.

To calibrate the pH sensor touch the screen under Measure. The alphanumeric keyboard will automatically launch and prompt you to enter the pH reading from your test kit. Enter this measurement and press the Enter button

Calibrate pH1		XX
	Actual	Measure
Point 1:	7.50	<input type="text" value="7.50"/>
Current Measurement		7.06
<input type="button" value="Reset"/>		<input type="button" value="OK"/>

pH Calibration Screen

Once you have done this, the alphanumeric keyboard will automatically close and the screen will return to the Calibrate pH menu.

If the Actual sensor measurement and the calibrated Measure differ by more than 1.25 the Controller will display the following warning message "WARNING, Sensor may be bad!". A large difference in the actual and calibrated sensor measurements may indicate that the pH sensor needs to be replaced.

To exit the pH Calibration screen, press the OK button.

**WARNING**

If the pH is below 7.4 or above 7.6 the ORP readings will be significantly affected. The ORP reading will be lower or higher than the actual ORP level in the system

It is important to maintain the pH levels in your system. High pH levels limit the ORP sensor's ability to read the ORP level. If the pH is high, the ORP sensor will read less than the actual level of sanitizer. A very low pH level will cause the ORP sensor to read higher than the actual level of sanitizer. The pH effect on the ORP sensor can cause the controller to feed more sanitizer than is really needed. Correctly programming the overfeed timers in your Controller will prevent this from occurring, but proper pH maintenance is the best course of action.

## ORP Calibration

The ORP calibration screen displays the following measurements:

**Point 1:** The ORP measurement uses a single point calibration. You will only need to make one adjustment to align this reading.

**Actual:** The actual sensor reading at the time of the last calibration.

**Measure:** The last manual ORP value entered in the controller.

**Current Measurement:** The current actual sensor reading

**pH:** The pH reading taken during the last ORP calibration.

Calibrate ORP1			XX
	Actual	Measure	pH
Point 1:	700	<input type="text" value="700"/>	7.50
Current Measurement			679
<input type="text" value="Reset"/>		<input type="text" value="OK"/>	

ORP Calibration Screen

To calibrate the ORP sensor, you must first balance the chemical levels in the pool until the PPM and pH levels are at the desired control point. Before making any adjustments to the calibration of the Controller, measure the sanitizer levels in your pool or spa using a standard hand measurement test kit. Your test kit will probably measure the sanitizer level in parts per million, or PPM. If this is the case, you will need to use the ORP calibration curve to find the ORP equivalent of your current PPM measurement. To use the chart below, your pH must be between 7.4 and 7.6. If your pH is not in this range, you may wish to use the expanded chart on p. . However, you should never calibrate your ORP if your pH is not at or very close to your desired set point.



The ability of the ORP sensor to correctly measure the sanitizer content in the water is affected by the pH level of the water. If the pH is above the set point, the ORP measurement taken by the Controller will be lower than the actual ORP measurement. When the pH is below the set point, the ORP measurement taken by the Controller will be higher than the actual ORP measurement.

### ORP Calibration for Large Systems

When working with especially large bodies of water, especially ones being opened for the first time, it can take hours, or even days to bring the water in to balance and close to your desired set point. There may be a few occasions where the operator is not able to wait until the water has been balanced before preparing the Controller to control and monitor the system. While it is always best to allow the water to come in to balance and reach the desired set point before calibrating the sensors, it is possible to use an alternate calibration method to adjust the sensor readings before the water has been fully balanced.

The alternate calibration method uses the belief that a change of 1.0 PPM results in a difference of 10 mV in the raw or actual ORP sensor reading. The sensor is calibrated based on the current raw voltage reading. The calibration will be adjusted to allow the controller to feed the appropriate amount of sanitizer to reach the set point.

To use this alternate calibration method, your pool or spa must measure at least 1.0 PPM and have a pH of 7.5. The difference between the current PPM and the desired PPM should be identified. Then, identify the ORP or raw voltage reading that corresponds with your desired set point. The ORP reading is then calibrated 10 mV below the set point for each PPM of difference between the current level and the desired set point.

#### Example:

Your desired set point is 700 ORP, which is equivalent to 2.0 PPM. Your system is currently at a PPM of 1.0. The current uncalibrated ORP display shows a measurement of 740mV.

We will need to lower our current ORP reading by 10mV from the set point for every unit of PPM change. Our desired PPM change is 1.0 PPM, so we will need to set our current ORP reading 10mV below our ORP set point. The ORP set point is 700mV. Our current reading should be calibrated 10mV lower, at 690.



## Calibrating Calculated PPM

The Calculated PPM calibration screen displays the following measurements:

PPM: The calculated PPM measurement to be adjusted with the correct manual measurement.

ORP: The current ORP measurement used as a reference point for calculated PPM.

pH: The current pH measurement used as a reference point for calculated PPM.

Cal Calculated PPM		XX
PPM:	0.01	
ORP:	486	
pH :	7.06	
<input type="button" value="--"/> <input type="button" value="-"/> <input type="button" value="+"/> <input type="button" value="++"/> <input type="button" value="Reset"/> <input type="button" value="OK"/>		

Calculated PPM Calibration Screen

Measure the current PPM level of your system using a standard test kit. Depending on your results, you may need to adjust the calculated PPM measurement so that it is in alignment with the measured PPM level of the system.

To make adjustments to the calculated PPM, touch the + or - buttons at the bottom of the screen to increase or decrease the calculated PPM reading. When the reading is far away from the manual measurement use the ++ or -- to increase or decrease the calculated reading more rapidly.

Note: Refer to Section on calibrating measured PPM. Refer to Section , PPM vs. ORP Chart or Section , Calculated PPM; to confirm the correct measurements.

## Calibrating Temperature

The Temperature Calibration screen displays the following items:

**Point 1:** This is a single point calibration. You will only need to make one adjustment to align this reading.

**Actual:** The last actual sensor reading taken before the last calibration.

**Measure:** The last manual temperature measurement entered in your Controller.

**Current Measurement:** The current temperature sensor measurement.

Calibrate Temperature 1		XX
	Actual	Measure
Point 1:	76.9	<input type="text" value="76.9"/>
Current Measurement F:		77.5
<input type="button" value="Reset"/>		<input type="button" value="OK"/>

### Temperature Calibration Screen

Use a thermometer to take an accurate temperature reading. If the difference is more than a degree, but less than five degrees, you will probably want to calibrate the temperature reading. Before making additional adjustments, press the Reset button to clear any existing calibrations on this sensor.

To calibrate the temperature sensor touch the screen under Measure. The alphanumeric keyboard will automatically launch and prompt you to enter the temperature reading from your test kit. Enter this measurement and press the Enter button. Return to the Calibrate Temperature menu and touch OK. The change will be recorded along with the sensor reading at the time the calibration was made.

The temperature sensor in the Controller is generally very accurate and should not need to be calibrated more than a few degrees. A difference of more than a few degrees between the temperature sensor measurement and the actual temperature of the water in your system is an indication that there may be a problem with the installation location.

The most commonly observed issues with temperature sensors are:

- Temperature variance within the system itself. The temperature is not always the same at the Controller temperature sensor as at the heater or other measurement locations. Outdoor temperatures, time of day, and whether the equipment is inside or outside can also cause the temperature to vary within the system.
- The temperature sensor may be damaged. Water inside the sensor will cause it to malfunction. Remove the temperature sensor from the flow cell and inspect the cable for damage. If the sensor is damaged it must be replaced. Remove the sensor and let it dry out. A working temperature sensor will have a resistance of 10,000 ohms at 76° F.

## Calibrating Digital Flow

The Controller is compatible with most digital flow sensors. Digital flow sensors improve accuracy, especially when measuring low flows. The Calibrate Flow screen displays the following items:

Name: Column listing of flow readings updated every ten (10) seconds. The name indicates the number of the flow sensor, F1, 2, or 3 and the module in the Controller that reads the flow sensor, M1, 2, or 3. Each module can monitor two flow sensors.

K p/g: The K factor is a flow constant used in the calculation of the flow rate. The K factor will be supplied by the manufacturer of the flow sensor you are using. The K factor may be in pulses per gallon or pulses per liter. Consult the sensor manufacturer's guide for more information on calculations.

Flow: The flow registered by the flow sensor in gallons per minute. This reading is refreshed every ten (10) seconds.

Volume: The total flow of water, in gallons, through your system since the last time this value was

Calibrate Flow				XX
Name	K p/g	Flow	Volume	
F1M1	100.00	0		
F2M1	0.0			
F1M2	3328.0	0		
F2M2	0.0			
F1M3	0.0			
F2M3	0.0			
Flow updates every 10 seconds!				
Enter the Flow Constant				
K - Pulses / Gallon or Pulses / Liter				<input type="button" value="CHANGE"/>

Calibrate Digital Flow Screen

### To install a digital flow sensor

- 1) Follow instructions that accompany the sensor.
- 2) Install sensor into the waterline.
- 3) Unplug the controller.
- 4) Hook up the red wire into the +12 terminal in the Acu-Trol controller.
  - AK110: Main Board
  - Controller: Sensor Card
  - AK400: Relay Board
  - AK2100: Sensor Card
- 5) Hook up the black wire into the switch terminal in the Acu-Trol controller.
- 6) Hook up either the green or unshielded copper wire (ground) into the GND terminal in the Acu-Trol controller.
- 7) Plug in and then turn on the controller.
- 8) Program the controller to utilize the sensor.

Calibrating any digital flow sensor requires that the K factor provided by the manufacturer be included in the flow calculations. The K factor plays an important role in adjusting the flow rate to account for pipe size, material, and other items.

Select the flow sensor you wish to calibrate using the directional arrows on the right hand side of the screen. Once you have selected a flow sensor, press the CHANGE button. The alphanumeric keyboard will automatically open and prompt you to enter the manufacturer supplied K factor or flow constant for this flow sensor. Once you have finished, press the Enter button to exit the alphanumeric keyboard and save your work.

You will automatically be returned to the Calibrate Flow menu. Any changes you have made will be automatically recorded, along with the sensor flow reading at the time the calibration was made.

---

## Conductivity Setup

Conductivity sensors measure the ability of a specific body of water to conduct an electric current. Conductivity is measured by passing a current between two electrodes that are placed into a sample of water. The unit of measurement for conductivity is microSiemens (uS/cm). Electricity flows more easily through water with dissolved ions, salts, and other substances than it does through pure water. Conductivity measurements can provide information about the chemical makeup of your pool or spa, telling you how much of the liquid is water and how much is other dissolved material. These measurements are often used to track Total Dissolved Solids and salt content in pools and spas.

The Conductivity Setup screen displays the following values to be entered:

**Cell Constant K:** Refer to sensor manufacturer's manual to determine the K factor and multiply this number by 1000; the resultant number should be entered. Example: For a sensor with a cell constant of 0.1, 100 would be entered.

**TDS factor:** These default values are typically 500, which is half of the conductivity (uS) in PPM.

**NACL Factor:** These default values are typically 500, which is half of the conductivity (uS) in PPM.

Enter the values for the Conductivity Setup screen. Use the arrow keys to highlight the item to change and touch the Change button and enter the value on the keyboard, touch Enter. Repeat the above for all values.

## Entering a Cyanuric Acid Measurement

Use a standard test kit, or take a water sample to your local pool supply store to have it analyzed. An accurate Cyanuric acid measurement is important to assure the accuracy of the calculated water balance indices. You will probably want to re-enter the Cyanuric acid level measurement at least once every three months to ensure the accuracy of the calculations done by the Controller.

To enter a Cyanuric acid measurement, press the Cyanuric acid menu item (CYA) in the calibration menu.

Module	1	2	3	XX
PH	ORP		PPM	T
Flow	Cyn			
Cond	Alk		TDS	Hard

The alphanumeric keyboard will automatically launch and prompt you to enter the Cyanuric Acid reading from your test kit or water analysis. Enter this measurement and press the Enter button. The alphanumeric keyboard will automatically close and the screen will return to the Calibration menu.

## Entering an Alkalinity Measurement

Use a standard test kit, or take a water sample to your local pool supply store to have it analyzed. An accurate Alkalinity measurement is important to assure the accuracy of the calculated water balance indices. You will probably want to re-enter the Alkalinity level measurement at least once every three months to ensure the accuracy of the calculations done by the Controller.

To enter an Alkalinity measurement, press the Alkalinity menu item (Alk) in the calibration menu.

Module	1	2	3	XX
PH	ORP		PPM	T
Flow	Cyn			
Cond	Alk		TDS	Hard

The alphanumeric keyboard will automatically launch and prompt you to enter the Alkalinity reading from your test kit or water analysis. Enter this measurement and press the Enter button. The alphanumeric keyboard will automatically close and the screen will return to the Calibration menu.

### Entering a Total Dissolved Solids Measurement

Use a standard test kit, or take a water sample to your local pool supply store to have it analyzed. An accurate Total Dissolved Solids measurement is important to assure the accuracy of the calculated water balance indices. You will probably want to re-enter the Total Dissolved Solids level measurement at least once every three months to ensure the accuracy of the calculations done by the Controller.

To enter a Total Dissolved Solids measurement, press the Total Dissolved Solids menu item (TDS) in the calibration menu.

Module	1	2	3	XX
PH	ORP		PPM	T
Flow	Cyn			
Cond	Alk		TDS	Hard

The alphanumeric keyboard will automatically launch and prompt you to enter the Total Dissolved Solids reading from your test kit or water analysis. Enter this measurement and press the Enter button. The alphanumeric keyboard will automatically close and the screen will return to the Calibration menu.

## Entering a Hardness Measurement

Use a standard test kit, or take a water sample to your local pool supply store to have it analyzed. An accurate Calcium Hardness measurement is important to assure the accuracy of the calculated water balance indices. You will probably want to re-enter the Calcium Hardness level measurement at least once every three months to ensure the accuracy of the calculations done by the Controller.

To enter a Calcium Hardness measurement, press the Calcium Hardness menu item (Hard) in the calibration menu.

Module	1	2	3	XX
PH	ORP		PPM	T
Flow	Cyn			
Cond	Alk		TDS	Hard

The alphanumeric keyboard will automatically launch and prompt you to enter the Calcium Hardness reading from your test kit or water analysis. Enter this measurement and press the Enter button. The alphanumeric keyboard will automatically close and the screen will return to the Calibration menu.

## Global Disable

The Global Disable feature is used to turn OFF any MPS relay group for a specified period of time. The Global Disable feature is particularly useful when servicing feed pumps, pipes, and other liquid carrying devices.

Select MPS grouping by touching directly on number grouping. Select one of four time periods on the right. The highlighted items are disabled according to the time period selected.



By touching in the x in the upper right corner, the disabling will be activated. An MPS that has been globally disabled will remain disabled, even if the power is cycled.



Highlighted Items are Disabled				XX
Relays	1 - 4	5 - 8	9 - 12	13 - 16
Soft	1 - 4	5 - 8		10 Mins
Alarms	1 - 4			30 Mins
PVE	1 - 4	5 - 8		4 Hrs
				12 Hrs
PVE	9 - 12	13 - 16		

### Clear Overfeeds

Select to quickly clear the overfeed timers. The clear overfeed in the system reset menu requires the operator password. In this screen you may clear the overfeed timers with the service password.

RESET MENU	XX
Reset Controller	
Reset All Sensor Calibrations	
Reset Totalizers	
Reset All Defaults	
Reset MPS Total On Timers	
Reset Overfeed Timers	
Reset General Settings	
Reset MPS's to Factory Defaults	
Reset Communications	
Reset All MPS programming	
Reset Data	CHANGE

Reset Screen

## Enter Password

Touch Enter Password to open the keyboard screen and type in the password. See Security section for password levels. When the security features are enabled, a number other than 0 will be displayed next to the x in the upper right corner of the screen. The password must be entered before accessing the controller for servicing and reconfiguration.

## Troubleshooting

This section lists common problems with the most likely solution

Part	Problem	Solution #1	Solution #2
Alarm	High pH alarm ON	Increase ON time (CO <sub>2</sub> = slower reaction, needs more time ON)	
Modem	Modem error	Check com-port for modem	
Flow Cell	Magnet will not go up	Clean Filter	Back wash main filter.
ORP/pH Sensor	Readings bouncing	Clean Sensor	Check Flow
Flow Switch	Not working	Check for magnet	
Alarm	Overfeed alarm ON	Increase overfeed time	
Program	Relay 1 & 2 not turning ON but work manually	Check flow switch	Check Relay set points
Sensors	Readings not changing	Short (+)(-) on sensor card ORP should = 0, pH = 7.0	
Computer	Can not get into comm screen with new computer	Reinstall software	Search for threed.vbx files

## Section 12 Optional Features

The Advanced setup menu contains the menus that will allow you to configure and activate optional equipment for your Controller. This menu is used to set up your AK Color system or to set up communication with an AK245 or an AK250.

To open the advanced setups menu, Touch the Adv Setups menu item in the Configuration menu. Open the desired setup by directly touching on the name of the setup. Note: The Future Setups will be used for later additions.

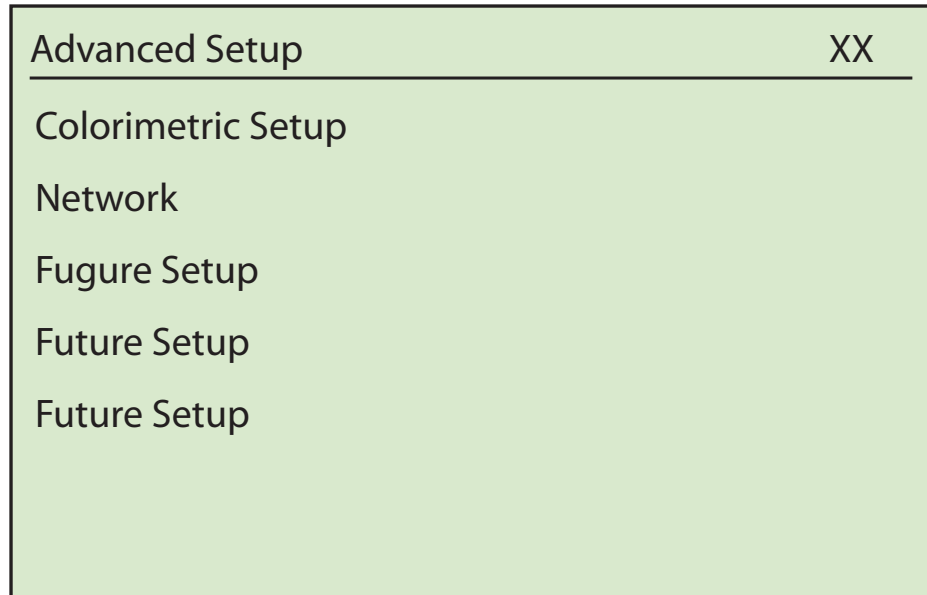

Advanced Setup Screen

### AK Color Setup

#### Overview

The AKCOLOR is a colorimetric method Chlorine Analyzer designed to work in conjunction with Acu-Trol controllers. The AKCOLOR measures the amount of free chlorine present in a body of water using a process very similar to a traditional hand check. The colorimetric measurement method provides some of the most accurate measurements available to pool and spa operators. The AKColor is much less sensitive to varying water conditions including pH and salinity. This information can be used to control Chlorine feed pumps and Alarm conditions.

#### Expansion Modules

The Controller requires the correct expansion module to be installed before any of the AKCOLOR functionality can be accessed.

Model	Module	Capable of the following measurements
Controller	AK615/AK616	Measures pH, ORP, temperature, PPM Free Cl (AK216 also measures conductivity.)

## Overview

Each installation of an AKCOLOR can be different. This manual gives the basic principles to be applied for any specific installation as follows:

1. Identify the equipment to be connected.
2. Locate a suitable 115 VAC outlet for the 12VAC wall pack. Determine if an external ON/OFF switch is necessary.
3. Wire the (2) wires from the 12VAC wall pack through a strain relief to the control board connections marked AC input. **DO NOT CONNECT** to the GND connection, this will cause damage! Do not plug in the wall pack to the supply voltage.
4. The AKCOLOR is supplied with a 60" long sample hose. This is the maximum distance from a sample point, such as a flow cell, to ensure a fresh sample is collected each time. The AKCOLOR operates in a low water waste mode by only flushing the test chamber just before and just after the sample time. If the sample hose is lengthened beyond 60" a fresh sample may not be obtained during each measurement.
5. The ¼" sample line can now be attached. The pressure must be less than 10PSI or the solenoid will not be able to close. The pressure must be greater than 4PSI or the sample chamber will not be cleaned out completely in 30 seconds. The length of the supply tube can be shortened to reduce the sample refresh time.
6. If the AKCOLOR is an upgrade to an existing Controller the AK215 or AK216 sensor card must be installed: With power OFF at the Controller unscrew and open the front metal panel. Install the sensor card in an available slot. Secure with the two (2) screws.
7. With the power OFF to the Controller and the AKCOLOR, route the 4-wire cable through the small strain relief into the Controller.
8. Connect the 4-wire cable from the AKCOLOR to the Controller sensor card as follows.
  - 1) GND BLACK To GND
  - 2) SW WHITE To DFL2,
  - 3) CL- RED To PPM-,
  - 4) CL+GREEN To PPM+.
 Refer to Detail below.
9. After all wire connections are complete, close the the Controller cover. Leave excess wire outside the controller enclosure. Do not stuff excess wire inside the controller as this may cause excess strain on sensor and relay connections.
10. Connect a ½" ID hose to the barbed drain connection at the bottom of the AKCOLOR and run this hose to a drain. **DO NOT** run the drain back into the water source being sampled!
11. Test the plumbing for leaks.

13. Perform the Setup and Startup procedures

**WARNING**  
Have a licensed electrician perform all electrical wiring. It is important that any electrical work be compliant with all electrical codes in the area.

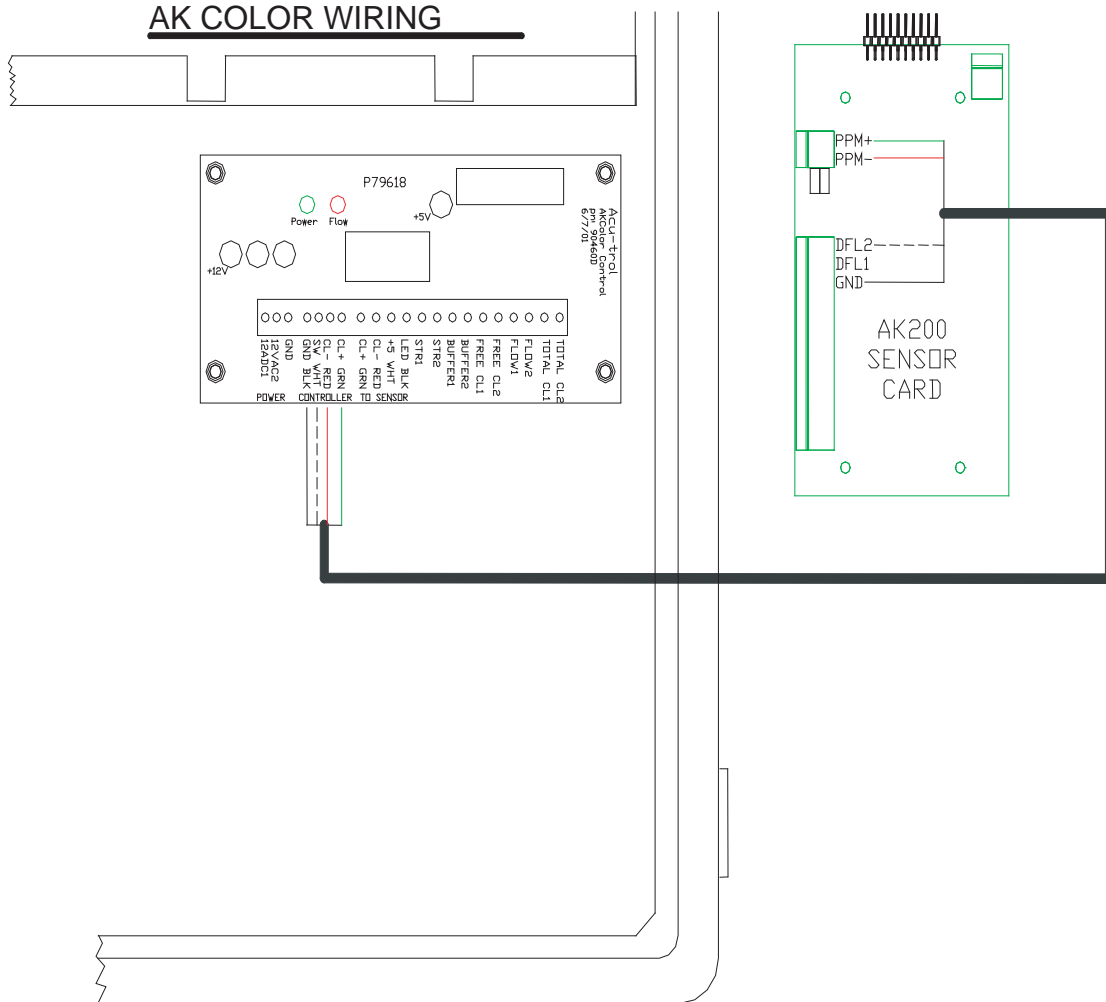





## AKColor Configuration



To configure the Controller for the AKCOLOR you will need to open the configuration menu. Once in the configuration menu, select the System sub-menu.

Display	Config	Service	XX
	General Setup		
	System		
	Adv Setups		
	Programming		
	Communications		

After opening the System sub-menu, select the Hardware sub-menu by pressing the Hardware button.



System Menu		XX
Time	: 11:14:00	
Date	: 05/30/06	
Weekday	: Monday	
Units	: English	
HOA	: Enabled	
Program Mode	: Easy	
Serial #	: 10000	
<input type="button" value="HARDWARE"/>	<input type="button" value="DISPLAY"/>	<input type="button" value="PRINT"/>
<input type="button" value="SECURITY"/>	<input type="button" value="Reset Menu"/>	<input type="button" value="CHANGE"/>

Select which sensor module (AK615 or AK616) is installed in the Controller using the up and down arrows  . Press CHANGE to cycle to A6215 or AK616. Press either x in the upper right corner when hardware configuration is done. Select Yes to reset the appropriate relays to factory defaults.

Hardware Configuration		XX
Module 1	: AK610, pH, ORP, T	
Module 2	: AK613, pH, ORP, T, Cond	
Module 3	: Empty	
RS232 Type	: PC	
Relay Type	: 8 Relay Type	
High Speed Modem	: MT5600	
UART(RS485+Printer)	: EMPTY	
512K RAM Expansion	: Empty	
		<input type="button" value="CHANGE"/>

## AKColor Setup

Open the System Menu, and select the Advanced Setup sub-menu.

System Menu		XX
Time	: 11:14:00	
Date	: 05/30/06	
Weekday	: Monday	
Units	: English	
HOA	: Enabled	
Program Mode	: Easy	
Serial #	: 10000	
<input type="button" value="HARDWARE"/>	<input type="button" value="DISPLAY"/>	<input type="button" value="PRINT"/>
<input type="button" value="SECURITY"/>	<input type="button" value="Reset Menu"/>	<input type="button" value="CHANGE"/>

Open the Advanced Setup sub-menu, and select Colorimetric Setup. You are now ready to prepare your AKColor system for operation.

Advanced Setup		XX
Colorimetric Setup		
Network		
Fugure Setup		
Future Setup		
Future Setup		

Ctime1, 2: This represents cycle time 1 & 2. You can enter values from 4-10 minutes for cycle time 1 and 4 - 30 minutes for cycle time 2. The cycle time has been set for 4 minutes sample. NOTE: the short cycle times are good for small water systems that can have sudden changes in PPM levels which need fast response from the controller.

Begins: This represents the time of day that you want the sample cycle time to come into effect. You can enter values from 0 – 23. When setting your cycle times, be sure that cycle time 1 is less than cycle time 2.

NOTE: if Ctime1 is set for fast cycles, such as 4 minutes, you can set Ctime2 for a slow cycle to save chemicals.

## AKColor Diagnostic Screen

The AKCOLOR Diagnostic Screen allows the operator to view information about the operation of the AK-COLOR. In this screen you can follow the progress of a sample, ensure that the sample chamber is properly functioning, and view the results of each test. To view the AKCOLOR diagnostic screen press the “c” in the upper right corner from either the Display/Specific or Summary screens.

AKCOLOR Diagnostic Screen					XX
#	ClrV	FPPM	TPPM	CPPM	CurV
1.					
2.	3.49	2.50	2.59	0.09	3.49
3.					
2.	80% Full, 193 Waiting				
Press Here for Manual Control					

**ClearV:** The AKCOLOR sensor takes measurements of the voltage in the water before and after the reagent reaction has taken place. The initial voltage, taken before any reagents are added to the water, is called the “clear voltage”.

**FPPM:** The AKCOLOR sensor takes measurements of the voltage in the water before and after the reagent reaction has taken place and calculates the Free PPM. The AKColor measures the difference in voltage between the initial “clear voltage” measurement and the post reaction “DPD Voltage. This difference is used by the Controller to calculate the PPM value of Chlorine in the water.

**CurV:** The current measurement displays the current AKCOLOR sensor voltage. This measurement is continually updated, and changes frequently. The highest current measurements will occur when the AKColor is filling and emptying the sample chamber. The lowest current measurements will occur just after the addition of the reagents to the sample.

**% Full:** Shows the percentage of chemicals left in the storage tanks. This is very helpful for remote locations using a modem, since you can call in at any time and check to see if more chemicals are needed.

**Count:** The length of time, in seconds for the AKColor to complete a single sample cycle. If you have a 4 minute sample cycle time you will see this number count from 1 to 240 seconds.



Chamber clean/dirty: Cleanliness of the sample chamber is an important factor in the accuracy of the AK-Color. The status of the glass test chamber is monitored by the AKColor and displayed here. When the sample chamber is listed as dirty, perform the cleaning procedure as directed in your AKColor manual.

Manual: The AKColor can be operated manually. Opening the AKColor Manual Operation Screen will disable the automatic functioning of the AKColor. This screen is used to test the function of each solenoid, and manually empty the sample chamber.

To test each solenoid, feed one drop of reagent from each of the storage bottles. To feed press the number under Buff, DPD, or TOT referring to the module the AKColor sensor card is installed. To purge all the stored reagents and the sample chamber, Press the appropriate module number in the Purge (PRG) column.

AKCOLOR Manual Operation						XX
Stir off	Buff Stir	DPD Stir	TOT Stir	Flow Prg	Prg Off	Off
1	1	1	1	1	1	1
2	2	2	2	2	2	2
3	3	3	3	3	3	3
Current Measurement						
2.55						

## AKColor Start Up

After AKCOLOR has been installed you should go through the following steps to start and verify its operation. Go to Service/Adv Setups/Colorimetric Setup.

Colormetric Setup					XX
	TOT	Ctime 1	Begins	Ctime2	Begins
1	7	15	20		
2	Off				
3					

TOT: On to enable Combined  
 Ctime: Cycle time in minutes  
 Begins: The hour the cycle begins

If new chemicals have been loaded into the storage tanks press the appropriate purge button ( Prg1, Prg2, or Prg3 ). The purge will take 10 seconds and clear the chemical lines of air.

Next press the appropriate “Vol” button ( Vol1, Vol2 or Vol3 ) until the % shown is close to the actual level of reagents. As the chemicals are used this number will drop letting you know how much is left in the storage tanks. This is only true if you reset this number after refilling the storage tanks.

Now adjust the sample flow rate into the sample chamber by throttling the inlet valve.

1. Close both clamps on the chemical feed lines.
2. Obtain an empty 12oz soda can.
3. Pull out the flow straw from the chamber and place in the soda can.
4. Go to the AKCOLOR Manual Operation screen. (Press Display/Specific or Summary, c in the upper right corner and then press Manual in the lower left corner.) Press the number of the module in the Flow column to start sample flow.
5. Fill the empty 12oz soda can with the water from the drain. If the inlet valve is throttled correctly it should take 2 minutes to fill the can.
6. When finished adjusting the flow press either x in the upper right corner to return to the AKCOLOR Diagnostic Screen. NOTE: returning from the manual screen always starts a new sample cycle.
7. Reattach the drain line.

8. Release both clamps on the chemical feed lines.
9. Go to Service/Adv Setups/Colorimetric Setup to set the time of day that a cycle time (CTime) becomes effective. "Begins" for CTime1 should be set one hour before normal daily chlorine consumption begins and "CTime1" should be set to sample often enough to track and control this chlorine consumption.
10. Compare the AKCOLOR reading to an actual hand measurement. If the two measurements vary, you may wish to calibrate the AKColor.
11. Call or visit over the next few days to fine-tune the setup.

### Cleaning the Sensor

The controller has the ability to determine when the AKCOLOR sample cell glass tube needs to be cleaned. When "Chamber dirty" appears in the AKCOLOR Diagnostic Screen or the clear voltage drops below 3.0 perform the following cleaning procedure:

1. Turn off the controller.
2. Remove the AKCOLOR cap that the three tubes enter into.
3. Add a couple drops of a mild acid. Let stand for 30 seconds. **WARNING:** do not remove stirring magnet located in bottom of test tube while cleaning.
4. With a Q-Tip clean the sides of the glass looking into the opening. Note that the cell is spaced away from the back panel making for easy viewing into the chamber. Test tube should now be clean.
5. Replace Test Chamber Cap and turn the controller back on.
6. Remove the rubber inspection cover to verify that the magnet is spinning.
7. If the system is powered down for more than 48 hours without flushing the tubes, crystallization may occur in the chemical supply tubes. When bringing the system back on line watch for leaks, bulges in tubes or bad readings.
8. In general the AKCOLOR runs best if it is run continuously once mounted and started up.
9. To disable the AKCOLOR simply unplug the wall transformer from the 115 VAC supply. The controller will still attempt to make readings but there will be no voltage as the colorimetric LED will not be powered up.

---

## Loading the AKColor Reagents

Read and follow MSDS sheets before working with chemicals. Wear the recommended personal protective equipment and know your facilities emergency action plan.

You will need to replace your DPD solution every 30 – 45 days whether or not it has been consumed by the reaction process. The efficiency of DPD solution diminishes over time and provides less and less accurate measurements.

### LOADING CHEMICALS

Pour “Dilute Sulfuric Acid Solvent” into the brown bottle marked “DPD – EDTA Solid Mixture”.

Cap the brown bottle and shake to make DPD solution.

Pinch clamps CLOSED on both the DPD and BUFFER feed lines.

Uncap the DPD storage tank and pour in the new DPD solution.

**WARNING:** do not mix more than 10% OLD DPD solution with NEW DPD solution created in step 1! (see CAUTIONS above)

Recap the DPD storage tank and place back onto the shelf.

Uncap the BUFFER storage tank and pour in the new “Free Chlorine Buffer”.

It is OK to mix any amount of OLD with the NEW, as long as the AKCOLOR was in continuous operation. There will always be more BUFFER left since the AKCOLOR uses more DPD than BUFFER during normal operation.

Cap and save any left over “Free Chlorine Buffer” it is safe to use for up to 6 months after initial opening.

Recap the BUFFER storage tank and place back onto the shelf.

Release both pinch clamps on the DPD and BUFFER feed lines.

If the tanks were empty or air bubbles appear in the DPD or BUFFER feed lines, **YOU MUST PURGE THE LINES.** See Section 12.1.7 on how to purge.

Reset the volume used indicators; they should read 99%, letting you know that the bottles are 99% full.

When this indicator goes down to 10% it will be time to load new chemicals. See your controller manual on how to reset the indicator.

Make sure AKCOLOR is operating normally.

---

## Calibration

The CALIBRATION MENU provides easy calibration of PPM.

Note: Always balance the system to desired pH, TDS, Conductivity and PPM levels prior to calibrating sensors.

1. Go to Service/Calibration Select the Module number on the top line that pertains to the matching AK215 board.
2. Select PPM
3. Press on the box under Measure
4. Enter in your hand-measured PPM value.
5. Press OK

## Preparation for Non-Operation

Remove any chemical from the bottles and fill with clean de-mineralized water. From the controller AK-COLOR setup screen perform the purge 4 times, 30 seconds apart. Unit may now be powered down for non-operation, bottles can be left in place. If non-operation will be more that 1 month all of the water should be drained from the system.

## Troubleshooting

### PPM Reading is 0 or 9.99

Check that the chemical bottles have not run dry.

The AKCOLOR checks for the differences in color from a clear sample and a sample that is a shade of purple. If the color doesn't change when DPD is added there is either no chlorine, too much, or something is wrong with the addition of DPD reagent. The controller will read zero or 9.99 in these cases.

Check that there is discharge from the drain line when the sample solenoid is turned ON. If you turn off the controller and back on again, the sample will flush for about 30 seconds. You can also remove the rubber inspection cap and verify that the magnet is spinning and that the green light is on.

### Internal Red LED is on Continuously

When you cycle power on the controller, the RED led on the AKCOLOR circuit board will turn off. After power is applied to the controller the RED led will periodically blink on for about ½ second. Every time this happens the AKCOLOR has received a command from the controller. If the RED led is on solid the AK-COLOR will not work. Check the following:

Verify that the 4-wire cable is connected properly.

Verify that the Controller is trying to control the AKCOLOR from the diagnostic screen.

If both of the above are correct and the RED LED is still ON solid there is a hardware problem, contact your dealer or Acu-Trol.

### The Clear Voltage is Reading > 4.0 Volts

Usually this is an indication that the RED and GREEN wire on either the controller or the AKCOLOR are backwards and need to be switched.

### The Clear Voltage is Reading < 2.3 Volts

Check the following:

Remove sample chamber view window plug and observe sample chamber during flushing. Sample chamber glass walls should appear clean with no brownish stains. If stains are evident sample chamber needs cleaning.

If during sample chamber viewing the water is pinkish or colored during flush then the sample flow rate is slow and needs to be increased. Note: the proper flow rate will fill a 12oz soda can in exactly 2 minutes.

Observe sample chamber and make sure the sample chamber light source is on.

Check to make sure the sample chamber light source and sensor are securely mounted. If not, gently slide both in all the way and gently lock in place with hold screws.

If both of the above are correct and the low voltage is still present there is a hardware problem, contact your dealer or Acu-Trol.

### DPD and Clear Voltage are the Same

If chemicals are newly mixed and installed verify that they are correct.

Verify that drain has no discharge when sample solenoid is off. If there is a continuous discharge the chemicals being added during sampling are being flushed before the sample readings are being taken. If debris is lodged in the sample solenoid it may be stuck partially open. The sample solenoid may need replacement.

Purge chemical lines to verify that no air is in tubes, recheck unit for normal operation after purge.

Verify the tubes are not blocked, verify that the hose clamp is open. Remove the DPD tube from the cover and manually turn on the DPD with the controller, verify that a drop comes out each time and that you hear the solenoid click. If a drop doesn't come out close the clamp on the tube and remove the tube from the input to the solenoid. Release the clamp for a short period being careful not to touch the DPD liquid if it should come out. If liquid comes out then the solenoid may be bad. If it doesn't the tube is blocked, check the filter. Make sure you re-attach and unclamp the tube.

### Chemicals Don't Last

DPD Chemicals are being used too fast. At a 5-minute sample rate the chemicals should last 1 month. Turn the unit off and remove the buffer and DPD tube from the cap. Verify that no fluid is leaking from the tube. If debris is lodged in the solenoid it may be stuck partially open, the solenoid needs to be replaced. This may happen if DPD chemicals are not mixed thoroughly before being poured into storage tanks.

---

## Inaccurate Readings

1. Remove AKCOLOR sample chamber viewing window plug and verify the magnet is spinning. The magnet will spin at 5, 42 and 95 seconds from the counter.
2. Verify that green light is ON in chamber.

## Network - AK245 Expansion Circuit Board

The AK245 is an expansion device for the Controller. It allows a user to add 4-20mA or 0-5V signal output for control of pumps, valves, chart recorders and other such devices. The AK245 is a microprocessor based, 0-25 mA/0-5 Volt signal generator capable of control of up to four (4) 0-25mA or 0-5 VDC input driven applications or devices. The AK245 can work in conjunction with other AK245 and AK250 signal controllers.

### AK245 Installation

Each electrical installation for the AK245 can be different. This manual gives the basic principles to be applied for any specific installation as follows:

1. Identify the new and existing equipment to be connected.
2. Determine the power supply.
3. Determine the placement of the equipment. 0-5V devices can't be far away from the controller if there is current in milliamps. This is because there will be a voltage drop (signal loss) just due to the resistance in wire itself. 4-20 mA devices can generally be farther away. It is always best to keep devices as close to the AK245 as possible.
4. Determine the AK245's mounting location, and mount.

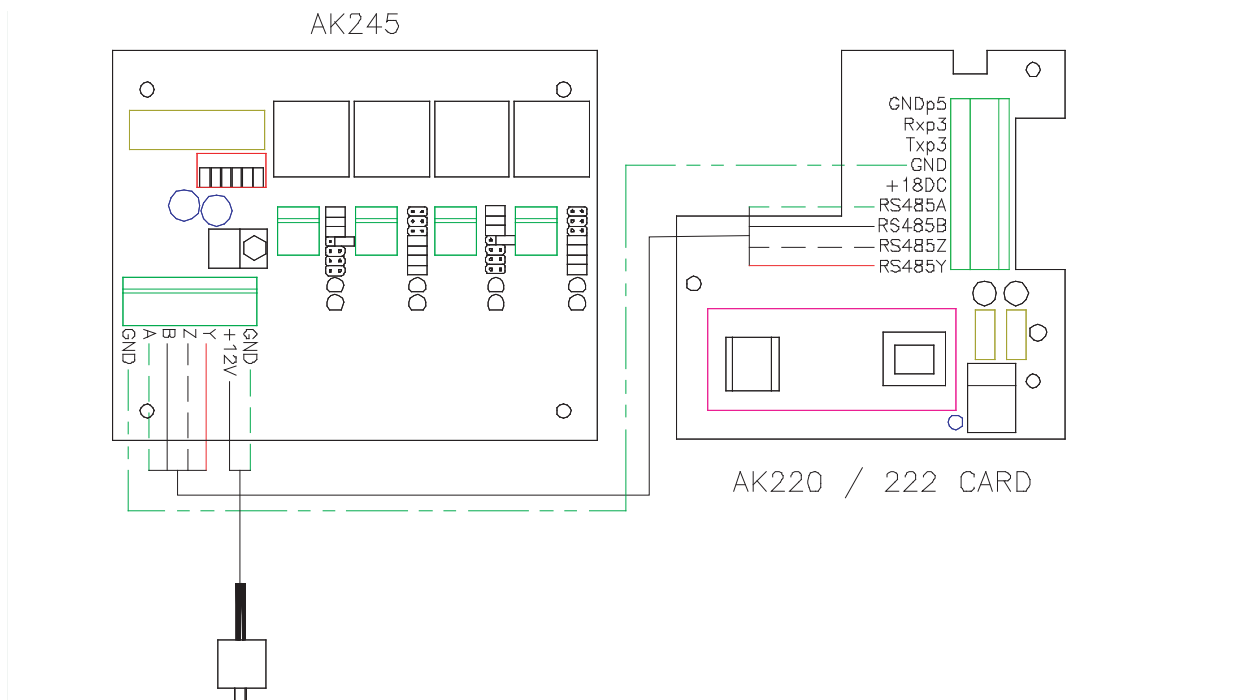



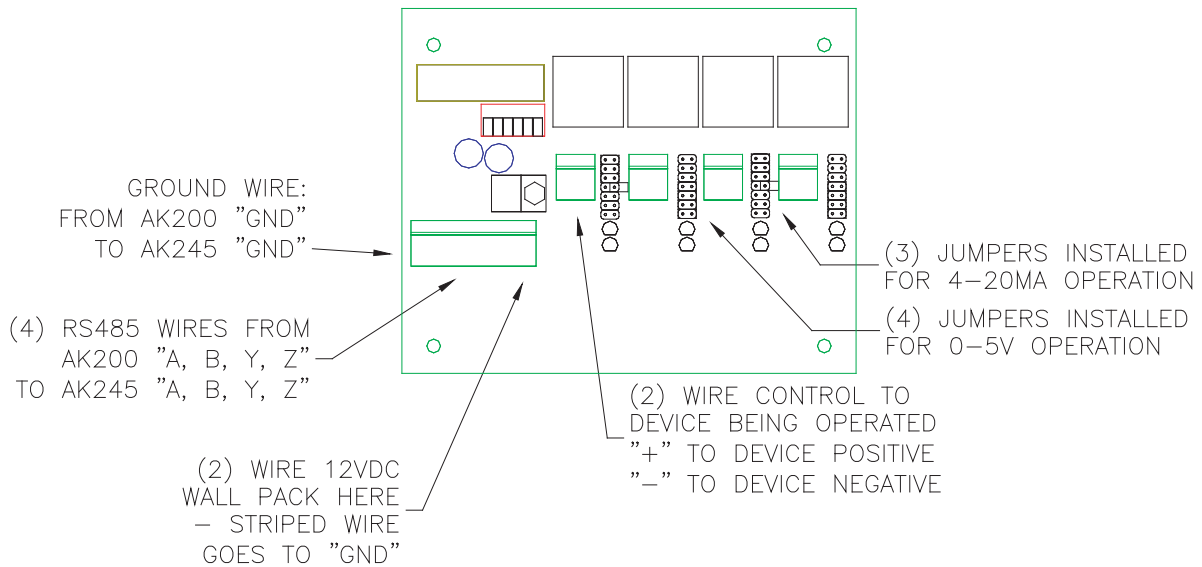

5. Connect the supply voltage. Use the +12VDC wall pack provided. The blue wire goes to the +12 and the brown wire goes to the GND. If one wire is striped connect it to +12 and the solid to GND.

NOTE: up to four additional AK245 or AK250 units can be daisy chained off any of the RS485 serial connections for a total of five units. The connection supports both RS485 and RS422. The maximum data-rate is 250KBaud (the Controller uses 19.2KBaud). The maximum cable length is 4000 feet using 26 AWG wire.

6. Connect the two (2) wire signal lines to the 4-20mA / 0-5V devices.
7. Set the AK245 address with the dip switches (see section below).
8. Set three (3) jumpers for 4-20mA operation or four jumpers for (4) 0-5V operation.

**WARNING:** Be sure to have a licensed electrician perform all electrical wiring. This is important, as they will be familiar with the electrical codes in the local area.

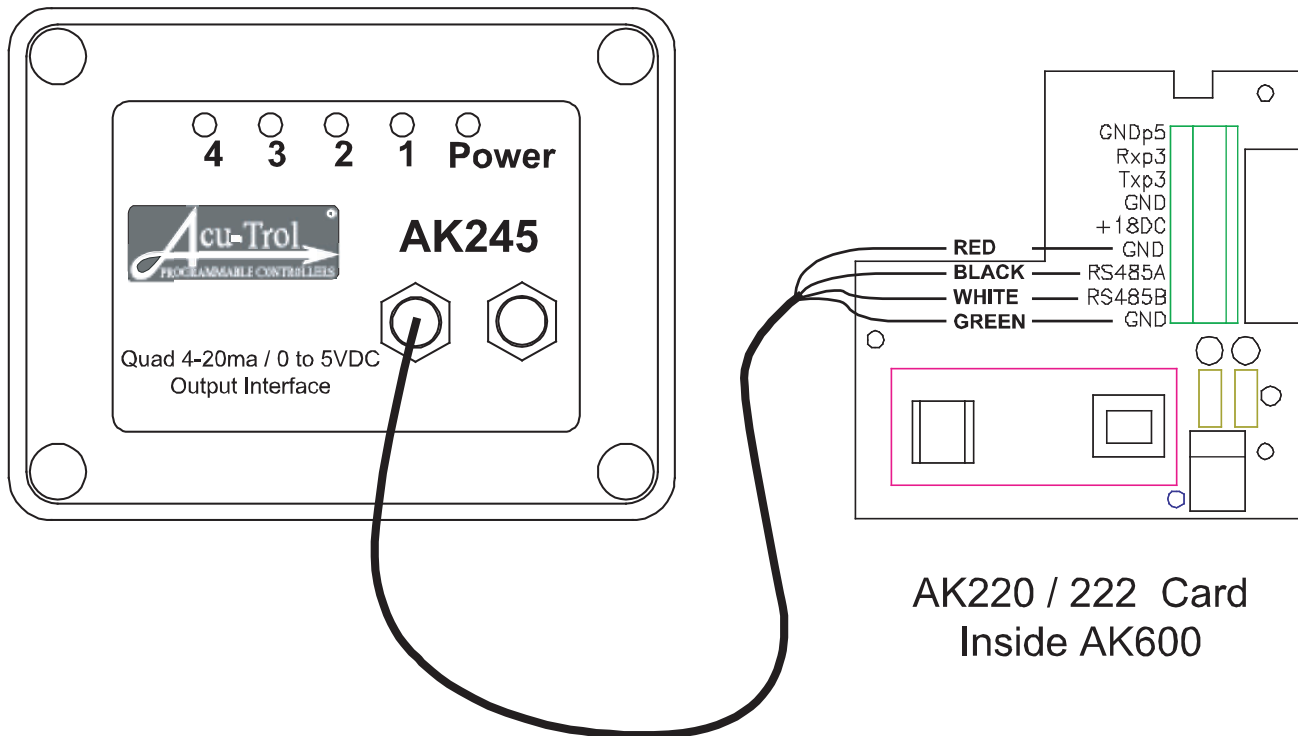

### Setting an AK245 Address

The AK245 uses a 4-dip switch interface for address setup. The dip switch interface is used to assign a two digit numeric address to each device attached to the RS485 serial control bus. Up to 15 different addresses can be assigned, if you have more than one AK245 or AK250 connected to a single Controller each one must have a different address.

The factory default configuration for the AK245 Dip switches is switch 1 down and switches 2-4 up. This gives the AK245 an address of “1”. Later when you program the Acu-Trol controller you will need to setup this address correctly. The table below contains all of the numeric addresses achievable and the corresponding dipswitch settings.

ADDRESS	SW1	SW2	SW3	SW4
1	Down	Up	Up	Up
2	Up	Down	Up	Up
3	Down	Down	Up	Up
4	Up	Up	Down	Up
5	Down	Up	Down	Up
6	Up	Down	Down	Up
7	Down	Down	Down	Up
8	Up	Up	Up	Down

---

## Output Signals

The AK245 can generate three different current signals, a 0-25 mA signal, a 4-25mA signal, and a 0-5V signal.

### 0-25MA Signals

The AK245 can generate a 0-25mA current signal at the request of an Controller via the RS485 serial connection. This signal can be used to drive devices, such as, motors, valves, and chart recorders. NOTE: only upper three jumpers installed for 0-25mA operation of a channel.

### 4-25MA Signals

The most common form of current control is 4-20mA. Usually the 4-20mA devices have a 250 ohm resistance across the signal inputs. This means that when 4mA is being delivered from the AK245 to the device a voltage of 1.0 VDC can be measured across the inputs. A 20mA current would generate 5.0 VDC. NOTE: only upper three jumpers installed for 4-20mA operation of a channel.

The Controller can be programmed to have the AK245 generate a 4.0 mA to 20.0 mA signal based on sensor readings. These 4-20 mA signals could then control a 4-20 mA pump. For example: an Controller is programmed to send a 4.0 mA signal at a pH of 7.5 and a 20.0 mA signal at a pH of 8.0. A 4-20mA variable speed pump is setup to start pumping acid at 4.1 mA. At 20.0 mA the pump would be pumping at full speed. Now whenever pH increases above 7.5 this pump will come on and start pumping acid to keep the pH down. If the pH keeps increasing the pump will speed up and pump acid even faster until at a pH of 8.0 or greater the pump will be pumping at top speed.

### 0-5V Signals

0-5V: The AK245 is also capable of producing a 0-5 Volt signal. This is much like the 0-25mA signal detailed above but uses voltage instead of current. NOTE: only lower four jumpers installed for 0-5V operation of a channel.

### Reversing

Some 4-20mA and 0-5V devices allow for reversing, such as, LMI pumps. This means that you can reverse the effects of the signal as to the operation of the device. Take the example above but instead of pumping acid lets pump base. Now the reversed variable speed pump will start pumping base at 19.9 mA. At 4.0 mA the pump would be pumping at full speed. Now whenever pH decreases below 8.0 this pump will come on and start pumping base to keep the pH up. If the pH keeps decreasing, the pump will speed up and pump base even faster until at a pH of 7.5 or lower the pump will be pumping at top speed.

## Electrical Specifications

The following electrical specifications in the table below must not be exceeded.

ITEM	DESCRIPTION	LIMIT
Communications	Serial 4 wires	RS485
Power	DC wall Pack	12VDC (500 mA)
0-5V signal	Number of devices per channel	1
4-20mA signal	Number of devices per channel	2





### Controller Network - AK245 Setup

The AK245 is a quad isolated, 0-25mA, 0-5VDC output converter designed to interface with the Controller controller system. The AK245 interfaces with the Controller using the AK620/AK622 communication/modem board and requires 12VDC from the wall pack power supply provided with the unit.





Step 1: To set up an AK245, you will need to open the Configuration Menu. Once in the CONFIGURATION MENU, select the Advanced Setups sub-menu. In the Advanced Setup screen, select the Network Setup sub-menu. and then select RS485 device to setup. Press the item line for the RS485 device you wish to configure. The individual set up screen for the device you have selected will automatically open.

Network Setup	XX
RS485 #1:	
RS485 #2:	
RS485 #3:	
RS485 #4:	
RS485 #5:	





Step 2: Use the arrow keys to select the Remote Address menu item. Press the CHANGE button and enter Remote Address that matches the address setup on the AK245 Dip Switches.

RS485 1:	XX			
Remote Address: 1				
Remote Model: AK245				
Channel Configuration				
CH SEN	Sen L	Sen H	OL%	OH%
1:Temp1	49.9	139.8	16.0	80.0
2:pH 1	5.00	9.99	16.0	80.0
3:	0	0	16.0	80.0
4:	0	0	16.0	80.0
   		CLR 4-20	CHANGE	





Step 3: Press the down arrow  to select the Remote Model menu item. Press the CHANGE button. This will toggle the Remote Model to AK245.

RS485 1: <span style="float: right;">XX</span>				
Remote Address: 1				
Remote Model: AK245				
Channel Configuration				
CH SEN	Sen L	Sen H	OL%	OH%
1:Temp1	49.9	139.8	16.0	80.0
2:pH 1	5.00	9.99	16.0	80.0
3:	0	0	16.0	80.0
4:	0	0	16.0	80.0
   			CLR 4-20	CHANGE





Step 4: Press  then use CHANGE to toggle the sensor selection in channel 1 to match the sensor that you want to use. Press CHANGE repeatedly until the correct item appears.

RS485 1: <span style="float: right;">XX</span>				
Remote Address: 1				
Remote Model: AK245				
Channel Configuration				
CH SEN	Sen L	Sen H	OL%	OH%
1:Temp1	49.9	139.8	16.0	80.0
2:pH 1	5.00	9.99	16.0	80.0
3:	0	0	16.0	80.0
4:	0	0	16.0	80.0
   			CLR 4-20	CHANGE

Step 5: Press  then use CHANGE to set Sen L to the sensor reading you wish signal low current or voltage to be equivalent to. The alphanumeric keyboard will automatically launch to allow you to enter the value.

RS485 1: <span style="float: right;">XX</span>				
Remote Address: 1				
Remote Model: AK245				
Channel Configuration				
CH SEN	Sen L	Sen H	OL%	OH%
1:Temp1	49.9	139.8	16.0	80.0
2:pH 1	5.00	9.99	16.0	80.0
3:	0	0	16.0	80.0
4:	0	0	16.0	80.0
   			CLR 4-20	CHANGE

Step 6: Press  then use CHANGE to set Sen H to the sensor reading you wish signal high current or voltage to be equivalent to. The alphanumeric keyboard will automatically launch to allow you to enter the value.





RS485 1: <span style="float: right;">XX</span>				
Remote Address: 1				
Remote Model: AK245				
Channel Configuration				
CH SEN	Sen L	Sen H	OL%	OH%
1:Temp1	49.9	139.8	16.0	80.0
2:pH 1	5.00	9.99	16.0	80.0
3:	0	0	16.0	80.0
4:	0	0	16.0	80.0
   			CLR 4-20	CHANGE





Step 7: Press  then use CHANGE to set OL% to 16.0 for 4mA low current (use 15.0 for 3.75mA to drive uncalibratable device off or closed) or to 00.0 for 0 V low voltage.





Step 8: Press  then use CHANGE to set OH% to 80.0 for 20mA high current or to 100.0 for 5 V high voltage.

Step 9: Repeat steps 4 – 8 for channels 2 through 4.

Step 10. Connect AK245 cables per the AK245 manual.

RS485 1:					XX
Remote Address: 1					
Remote Model: AK245					
Channel Configuration					
CH SEN	Sen L	Sen H	OL%	OH%	
1:Temp1	49.9	139.8	16.0	80.0	
2:pH 1	5.00	9.99	16.0	80.0	
3:	0	0	16.0	80.0	
4:	0	0	16.0	80.0	
   					
<input type="button" value="CLR 4-20"/>					<input type="button" value="CHANGE"/>

RS485 1:					XX
Remote Address: 1					
Remote Model: AK245					
Channel Configuration					
CH SEN	Sen L	Sen H	OL%	OH%	
1:Temp1	49.9	139.8	16.0	80.0	
2:pH 1	5.00	9.99	16.0	80.0	
3:	0	0	16.0	80.0	
4:	0	0	16.0	80.0	
   					
<input type="button" value="CLR 4-20"/>					<input type="button" value="CHANGE"/>

Pressing Clr will clear the values and sensor name for the selected channel. Pressing 4-20 will enter the default values for the selected sensor. The values may be edited using the arrow keys    .

## Resetting AK245 Setup

To reset the entire network go to “Config/System/Reset/More” and select “Reset Network Config”. This resets all five channels to empty.

### Controller Viewing AK245 Sensors

From the DISPLAY/SUMMARY, press the NEXT button twice to get to the Network view screen. This screen summarizes the setup of all five networks.

#### SCREEN FOR THE Controller

The screen below is based on the setup example above.

RS485 View:					XX
Net	CH1	CH2	CH3	CH4	SW1234
1.	7.51	79.8	0	0	0000
2.	0	0	0	0	0000
3.	0	0	0	0	0000
4.	0	0	0	0	0000
5.	0	0	0	0	0000
1.	pH1	Temp1			
2.					
3.					
4.					
5.					

↑
↓
←
→

CLR 4-20

CHANGE

NET: the numbers below represent the network setups 1 - 5. Each setup network has rows. The top row is the current reading of the assigned sensor and the second row is the name of the assigned sensor.

CH1,2,3,4: Represent the four channels of each network.

S1234: Represents the four switches of each network. A “0” indicates the switch is open, and a “1” indicates the switch is closed. (Only applies to AK250)

NEXT: Press this button to go back to the reading summary screen.

---

## Finishing and Testing

Once the controller system has been installed with applicable sensors and expansion modules the following steps are required for final system finishing and testing.

1. Plug in the supplied cable from the AK245 to the Controller. The cable can be plugged into either  
receptacle located on the cover of the AK245; it is keyed and can only be inserted one way. Be sure to insert the plug in all the way and turn the locking ring. Plug in the terminator plug in the remaining receptacle.
2. Route the signal wire pairs from each of the 4-20mA or 0-5V devices through a small strain relief to the (+ and -) of the controlling channel. The (+) should go to the (+) and the (-) should go to the (-).
3. Route the +12VDC power through a small strain relief. The blue wire should go to the +12 and the brown wire should go to GND. If one wire is solid and the other striped, the striped wire goes to +12.
4. Apply power to the AK245 by plugging in the 12VDC wall pack.

Test and operate the 4-20mA or 0-5V devices per the devices operating manuals.

## Troubleshooting

This section lists common problems with the most likely solution.

1. The green power LED does not come on when the 12VDC wall pack is on. Verify wall pack leads are securely attached to the green terminal block on the AK245.
2. The green channel light does not come on. Check to make sure that the RS485 serial connection is wired correctly. Check that the address set with the jumpers is the same one programmed into the Controller. Check that a program has been entered for that channel.
3. The device is not controlling properly. Make sure the two signal wires are not reversed. Make sure the device is powered.
4. **NO COMMUNICATION.** When the Controller is off or the network cable is not connected but the  
AK245/250 are turned on they will not operate properly. When this occurs the four green LED's will blink about four times a second. When communication is lost on the AK250 the LED's will start blinking in 5 seconds, on the AK245 the time is 20 seconds.







## ORP Chemical Standards

The Association of Pool and Spa Professionals Suggested Chemical Standards for Swimming Pools

Table for Pools	Minimum	Ideal	Maximum
Free Chlorine, PPM	1.0	1.0-3.0	3.0
Combined Chlorine, PPM	None	None	0.2
Bromine, PPM	2.0	2.0-4.0	4.0
pH	7.2	7.4-7.6	7.8
Total Alkalinity, PPM	60	80-100**	180
TDS, PPM	300	1000-2000	3000
Calcium Hardness, PPM	150	300-400	500-1000+
Cyanuric Acid, PPM	10	30-50	1580**
<p>* For Liquid Chlorine, Cal-Hypo and Lithium Hypo (for Gas Chlorine, Dichlor, Trichlor and Bromine Compounds 100-200 is ideal).</p> <p>** Except where limited by Health Dept. requirements often to 100 PPM.</p>			

TABLE FOR SPAS	Minimum	Ideal	Maximum
Free Chlorine, PPM	1.0	3.0-5.0	10.0
Combined Chlorine, PPM	None	None	.02
Bromine, PPM	2.0	3.0-5.0	10.0
pH	7.2	7.4-7.6	7.8
Total Alkalinity, PPM	60	80-100*	180
TDS, PPM	300	1000-2000	3000
Calcium Hardness, PPM	150	200-400	500-1000+
Cyanuric Acid, PPM	10	30-50	150**
<p>* For Liquid Chlorine, Cal-Hypo and Lithium Hypo (for Gas Chlorine, Dichlor, Trichlor and Bromine Compounds 100-120 is ideal).</p> <p>** Except where limited by Health Dept. requirements often to 100 PPM.</p>			

# Calculated PPM Calibration Curve

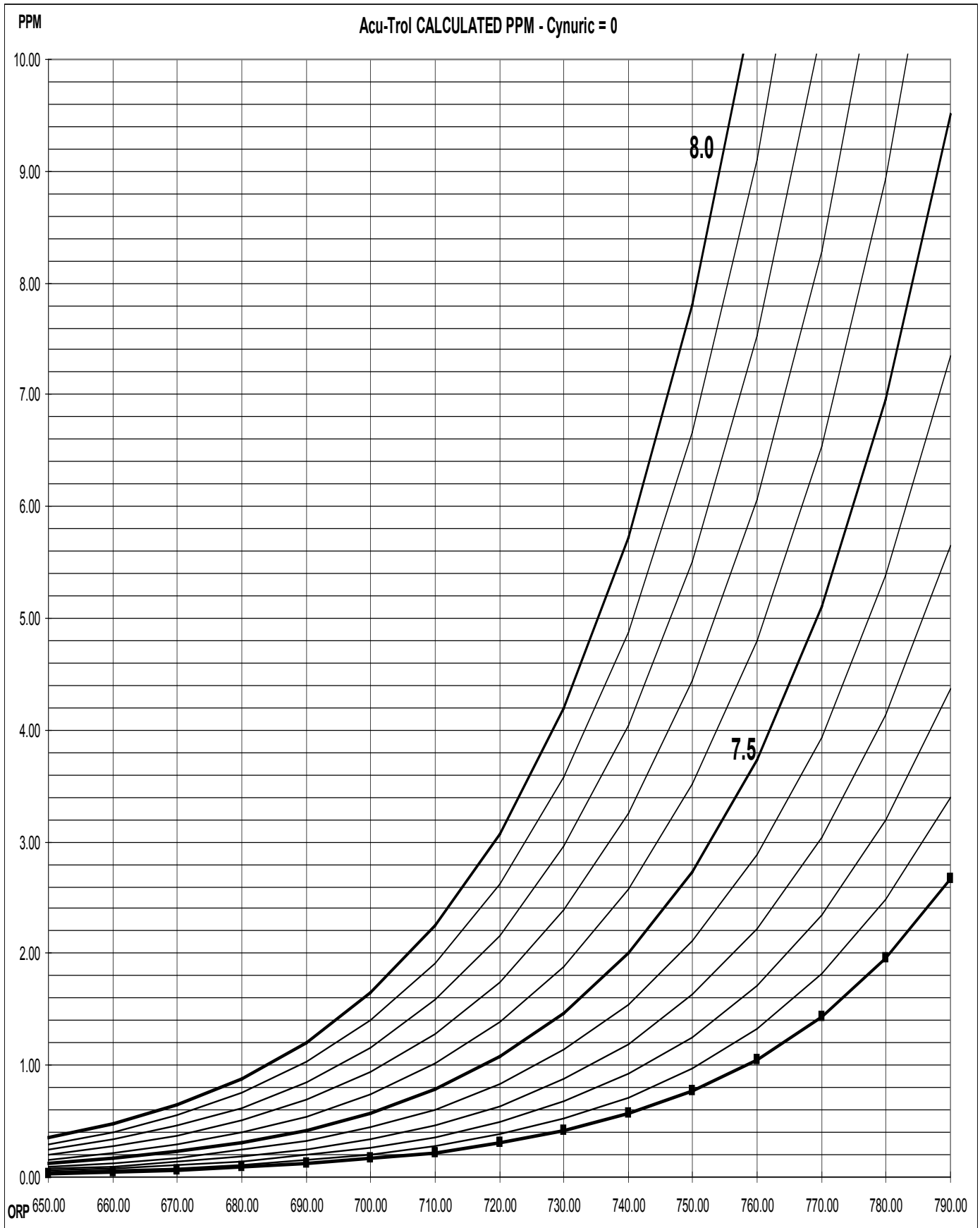

## Programming Command List

The output from the mini-programs (MPS) controls the state of the relays, alarms, pagers and voice calling. Each MPS includes up to 20 commands from the following list.

COMMAND	VALUE	DESCRIPTION
** ON **		Turns the current MPS ON.
** OFF **		Turns the current MPS OFF.
ON DELAY	$0 < t < 18:12:15$	When the MPS can turn ON, this delays it
Min Time ON	$0 < t < 18:12:15$	When in an ON cycle, the MPS will be ON for at least this long
Min Time OFF	$0 < t < 18:12:15$	When in an OFF cycle, the MPS will be OFF for at least this long
Max Time ON	$0 < t < 18:12:15$	When in an ON cycle, the MPS will be ON for at most this long
Max CTime ON	$0 < t < 18:12:15$	When in an ON cycle, the MPS will be ON for at most this long. The length of ON time is calculated once at the start.
Time ON ONCE	$0 < t < 18:12:15$	When in an ON cycle, the MPS will be ON time for this long.
Overfeed	$0 < t < 18:12:15$	An MPS will not be ON longer than this between over feed clearing times, as setup in the General screen.
Set Overfeed	$0 < t < 18:12:15$	An MPS will not be ON longer than this time unless the measurement is within 5% of the set point.
ON If Time>	$0 < t < 23:59:58$	The MPS will turn ON if the time is greater than this.
OFF If Time>	$0 < t < 23:59:58$	The MPS will turn OFF if the time is greater than this.
ON If Time<	$0 < t < 23:59:58$	The MPS will turn ON if the time is less than this.
OFF If Time<	$0 < t < 23:59:58$	The MPS will turn OFF if the time is less than this.
ON/OFF If pH >,<	$0.00 < x < 9.99$	The MPS will turn ON/OFF depending on the pH.
ON/OFF If ORP >,<	$0 < x < 999$	The MPS will turn ON/OFF depending on the ORP.
ON/OFF If PPM >,<	$0.00 < x < 9.99$	The MPS will turn ON/OFF depending on the PPM.
ON/OFF If Temp >,<	$31.9 < x < 211.9$	The MPS will turn ON/OFF depending on the temperature.
ON/OFF If Press>, <	$0.0 < x < 99.9$	The MPS will turn ON/OFF depending on the pressure.
ON/OFF If Cond >, <	$0 < x < 65535$	The MPS will turn ON/OFF depending on the conductivity.
COMPUTE MPS	$1 < x < 43$	The MPS will jump to the indicated MPS and compute it first
ON If Alarm ON,		The selected module indicates which alarm this is based ON.

## Programming Command List

COMMAND	VALUE	DESCRIPTION
OFF If Alarm ON		The selected module indicates which alarm this is based ON
ON If Overfeed	$1 < x < 24$	The MPS will turn ON if the overfeed timer has been reached for the indicated MPS.
ON If SET ALRM	$0 < x < 24$	The set point alarms are calculated from the alarm percentage. The MPS will be ON if the indicated set point alarm is ON. NOTE: the indicated MPS must have already been computed.
Date ON/OFF	$1 < x < 31$	The MPS will turn ON/OFF depending on the day of the month
WKday ON/OFF	$0 < x < 6$	The MPS will turn ON/OFF depending on the day of the week. 0 = Sunday, 6 = Saturday.
ON/OFF If MPS ON/OFF	$0 < x < 24$	The MPS will turn ON/OFF depending on the indicated MPS. NOTE: The indicated MPS must have been already computed.
ON/OFF If Sw ON/OFF	$0 < x < 5$	The MPS will turn ON/OFF depending on the indicated flow switch. Only module 3 can have 5 switches, the others can have 3.
Sequences ON		Will set the sequence state to the indicated sequences.
Prop GON %	$0 < x < 100$	The MPS will use this gain for calculating the proportional feed time on the ON time.
Prop GOFF %	$0 < x < 100$	The MPS will use this gain for calculating the proportional feed time ON the OFF time.
Manual ON Time	18:12:15	This is the time the MPS will be ON when turned ON in the manual mode from the service menu.
ON/OFF If dPress>,<	$0 < x < 99.9$	The MPS will turn ON/OFF depending on the differential pressure.
ON/OFF If SENSOR>,<		Controller Commands

### NOTE

When the value for any command is set to 0 the command is disabled.

### NOTE

Never set only one of the mixing time values to 0. If you set the MIN Time OFF to 0, you must also set the Max TIME ON value to 0.

**NOTE**

Max Ctime ON: In cases where the chemicals are injected ahead of the sensors this command will allow the readings to exceed the setpoint without stopping the feed cycle.

**NOTE**

Set Overfeed: This command is calculated based on the amount of feed time it would take to bring the worst case out of range measurement in to range.

EX. If it would take 1 gallon of CL to bring the pool from 0 to the setpoint of 2, and 35 gallon per day pumps are used, then this time should be set to  
 $1 \text{ gallon} / 35 \text{ gallons} = 41 \text{ minutes} * 60 \text{ seconds} = 86400 \text{ seconds.}$

**NOTE**

Overfeed can be used to limit the total amount of chemical injected in a period of time. In the above example, to limit the amount of CL fed to 3 gallons per day, the value entered would be  $41 * 3 \text{ minutes.}$

**NOTE**

There are On Conditions and Off conditions. If a command is an ON Condition, such as ON if pH > 7.5, it is not automatically true that this command will ensure that the function will be off if the pH is less than 7.5. An additional command OFF if pH < 7.5 would be necessary to ensure this.

## Proportional Feed Gain

The proportional feed gain command can be used on pH, ORP, PPM, conductivity and temperature. The gains are used to adjust the amount of deviation required for the ON time to be the maximum. The % value entered on this command is used to calculate when the full feed time is used. Any readings within this percentage of set point will cause a linear reduction in feed time.

Measurement	Set point	%	Full Feed Time at	½ Feed Time at
pH(Acid Feed)	7.50	10	8.25	7.87
ORP	700	5	665	683
PPM	2.00	10	1.80	1.90

## MPS Wizards

The following are some examples of wizards and explanations of their workings.

### Program for Super Chlorination

Super chlorination is the addition of excessive amounts of sanitizer at a specific time. The purpose is to oxidize the water, remove the small particles and keep the water crystal clear. The following questions should be asked before programming:

1. How often is super chlorination needed?  
Some of the more common choices are once every two weeks, once a week, or as needed. If a turbidity meter is installed the Controller can be programmed to automatically determine when super chlorination is needed.
2. How much sanitizer needs to be added? A common method for adding the sanitizer is to add a fixed amount or to add sanitizer until the ORP reaches a higher set point.

In the MPS Wizard, select Sanitizer/Super for the desired MPS. The resulting default commands are as follows:

```
Sanitizer/Super
CMD # 01 S S1 M2 SequencesON
CMD # 02 S 2 M2 WKday On Smtwtfs
CMD # 03 S S 2 M2 Off If Time>23:00:00
CMD # 04 S S 2 M2 Off If Time<22:00:00
CMD # 05 N S12 M2 Manual OnTime00:01:00
CMD # 06 N S1 M2 Prop GON % 10
CMD # 07 N S1 M2 On If ORP < 700
CMD # 08 N S 2 M2 On If ORP < 850
CMD # 09 N S1 M2 Max Time On 00:01:00
CMD # 10 N S 2 M2 Max Time On 00:10:00
CMD # 11 N S12 M2 Min Time Off 00:05:00
CMD # 12 N S1 M2 Overfeed 03:00:00
CMD # 13 N S 2 M2 Overfeed 04:00:00
CMD # 14 N S12 M2 Off if Sw Off 01
```

The values in this program that will probably need to be changed to meet the needs of your particular application are:

CMD 1: Standard sequence CMD#1 sets the current sequence to one (1) and turns OFF all others.

CMD 2: This command will turn ON sequence two (2) on Sundays. Note: day initials that are in CAPs are active.

CMD 3, 4: This command will turn OFF sequence two (2) before 10PM and after 11PM. The net result is that sequence two (2) will only be active between 10 and 11PM on Sundays. All other times, sequence one (1) will be active.

CMD 5: This command sets the manual time at one (1) minute for both sequences.

The remaining lines are the standard ORP control for both sequences; this gives the ability to have different mixing times for each sequence.



---

## Program for Dechlorination

De-Chlorination is the removal of excess sanitizer and is typically used immediately after a super-chlorination cycle. The amount of sanitizer added in a super-chlorination cycle may make the water undesirable for many hours; the de-chlorination cycle will quickly bring the pool back within limits.

In the MPS Wizard, select De-Chlor for the desired MPS. The resulting commands are as follows:

```
De-Chlor
CMD # 01 S S1 M3 Sequences ON
CMD # 02 S S1 M3 WKday On Smtwtfs
CMD # 03 S S1 M3 Off If Time>05:15:00
CMD # 04 S S1 M3 Off If Time<05:00:00
CMD # 05 N S1 M3 ** On **
CMD # 06 N S1 M3 Off if Sw Off 01
```

The following values should be changed to meet the particular application.

CMD 1: This command will ensure that no sequences are initially active. Notice that no sequences are selected, so they are all turned OFF.

CMD 2, 3, 4: These commands are set to do a fifteen (15) minute feed at 5:00 A.M. to remove the excess chlorine added during the above super-chlorination. If the times are changed in the super-chlorination programming then they will also need to be changed here too. It would also be possible to use the Time On Once command and have it turn ON when the super-chlorination MPS turns OFF but then it would happen whenever the controller is turned ON, since the MPS's are all OFF at the start.

CMD 5: This will turn ON the de-chlor feeder when sequence one (1) is ON.

CMD 6: This safety command will not allow turning on the MPS when there is no flow.

## Program for Auto Fill

Auto fill is the addition of additional water to the pool or spa when the water level is below a preset threshold. There are two (2) basic methods for determining when to add water. The first is to use a level sensor connected to a switch input to determine when water is needed. The second is to simply add a set amount each day based on experience. It is also possible to add water while a backwash cycle is in progress to compensate for the loss.

In the MPS Wizard, select Auto Fill for the desired MPS. The resulting program is as follows using a level sensor on the digital flow input one (DFL1) (not the flow switch input):

### Auto-Fill

1: Sequence ON	1
2: Manual ON Time	00:02:00
3: On if SW 2 ON	m2
4: On if SW 3 OFF	m2
5: On Delay	00:00:30
6: Min Time ON	00:00:04
7: Min Time OFF	00:00:30
8: Overfeed	01:00:00

The values in this program that will probably need to be changed to meet the needs of your particular application are:

Line 1: Standard sequence CMD#1 sets the current sequence to one (1) and turns OFF all others.

Line 2: Allows for manual control in the service menu.

Line 3: Disabled

Line 4: On when level switch connected to DFL1 goes OFF.

Line 5: On delay so that level sensor won't false trigger.

Line 6: Uses the Min Time ON command to keep the MPS on for at least this length of time.

Line 7: The relay will stay off for at least this length of time.

Line 8: Limit the daily on time.

### 13.6.4 Program for chemical Storage Tank Auto Fill

If solid sanitizer is used it must be mixed with water before the solution can be added to the pool or spa. Using the Chemical Storage Tank Auto fill program allows you to automate this mixing process. The method is to use one (1) MPS to control the water level in the mixing tank (using the Auto-Fill commands), and then another MPS that turns ON, when water is added to the Chemical Storage Tank to add the dry sanitizer.

In the MPS Wizard, select Cal Hypo Refill for the desired MPS. The resulting commands are as follows:

### Cal Hypo Refill

CMD # 01	S S1	M1 Sequences ON
CMD # 02	N S1	M1 ON if MPS ON NONE
CMD # 03	N S1	M1 Time ON ONCE 00:00:01
CMD # 04	N S1	M1 Min Time Off 00:15:00
CMD # 05	N S1	M1 Off if Cntr > 30
CMD # 06	N S1	M1 CntR=0 Midnight

## Program for pH

The following tables show the factory default programming for Acid Feed.

pH-Acid	
Line 1: Sequences ON	1
Line 2: Manual OnTime	00:01:00
Line 3: Prop GON %	3
Line 4: On If pH >7.50	m1
Line 5: On Delay	00:00:00
Line 6: Max Time On	00:01:00
Line 7: Min Time Off	00:05:00
Line 8: Off if MPS 0	ON
Line 9: Overfeed	01:00:00
Line 10: Off if Sw	Off 01

1. This command sets the sequences to 1, meaning all the following sequences enabled for sequence 1 will be calculated.
2. Sets the manual ON time for this relay to 1 minute. When the relay is manually turned ON from the service menu it will be ON for 1 minute, and then revert to normal control.
3. Sets the proportional feed to 3% (see Proportional Feed Section above).
4. The set point is 7.5. When the pH is greater than 7.5 the MPS will be ON. The following commands will modify this ON condition. If there were no more commands, this MPS would be ON as long as the pH was greater.
5. This can provide a delay before feeding your pH chemical.
6. This command will calculate how long the relay should be ON; the time listed in the command is the maximum time the relay can be ON.
7. The relay will be held off for the length of time specified. If the pH drops below the set point this timer will reset and the next time the pH exceeds the set point this timer will delay again.
8. Allow to disable pH control if another MPS is on.
9. This command will limit the amount of chemicals to be fed in a specified time period. If the overfeed timers are set to clear at 8AM and 5PM, then this MPS would not be ON longer than 1 hour in either of those 2 time periods. If the acid pump can feed 10 gallons per day, this would limit the acid to 0.42 gallons in either time period.
10. If there is no flow turn OFF relay. NOTE: This command is critical for safety and ensures the MPS will not be ON when there is no flow. Even if the previous commands determine the MPS should be ON, this is the last command and its calculation is final. EXAMPLE: If this command is located before the set point command, then the command will not change anything.

---

## Program for PPM

Note: The PPM is almost the same as the pH except the delay command is not used and the set point will be for PPM.

### Sanitizer

```
CMD # 01 S S1 M2 Sequences ON
CMD # 02 N S1 M2 Manual OnTime00:01:00
CMD # 03 N S1 M2 Prop GON % 10
CMD # 04 N S1 M2 On If PPM <2.00
CMD # 05 N S1 M2 Off if Sw Off 01
CMD # 06 N S1 M2 Max Time On 00:01:00
CMD # 07 N S1 M2 Min Time Off 00:05:00
CMD # 08 N S1 M2 Overfeed 03:00:00
```

## Program for Temperature

There are two ways to control a heater with the supplied MPS. The first (and default) is that when the heater turns on it will be held on using the Min Time On command. With this approach the heater will not turn off until the Min Time On value has passed, not when the setpoint is reached. The second approach uses the command Hold On and an Off Temperature. To enable set the Hold On value to 1 and make the turn off temperature a little higher than the setpoint.

```
Line 1: SequenceON 1
Line 2: Manual On Time 00:02:00
Line 3: On if Temp < 76.9 M3
Line 4: Hold On 0
Line 5: Off if Temp > 0.0 M3
Line 6: On Delay: 00:00:30
Line 7: Min Time On 00:02:00
Line 8: Min Time Off 00:02:00
Line 9: Overfeed 05:00:00
Line 10: Off if Sw 1 Off M3
```

If the Hold On feature is enabled and the off temperature isn't set to a non-zero value, when the relay turns on it will not turn off until the overfeed is reached

---

NOTES

## NOTES

---

NOTES



1620 HAWKINS AVE., SANFORD, NC 27330 • (919) 566-8000  
10951 WEST LOS ANGELES AVE., MOORPARK, CA 93021 • (805) 553-5000  
WWW.PENTAIRPOOL.COM

All Pentair trademarks and logos are owned by Pentair, Inc. Pentair Aquatic Systems™, Acu-Trol® are trademarks and/or registered trademarks of Pentair Water Pool and Spa, Inc. and/or its affiliated companies in the United States and/or other countries. Unless expressly noted, names and brands of third parties that may be used in this document are not used to indicate an affiliation or endorsement between the owners of these names and brands and Pentair Water Pool and Spa, Inc. Those names and brands may be the trademarks or registered trademarks of those third parties. Because we are continuously improving our products and services, Pentair reserves the right to change specifications without prior notice. Pentair is an equal opportunity employer.

© 2012 Pentair Aquatic Systems. All rights reserved. This document is subject to change without notice.

