



# THS SERIES® FILTER DIAPHRAGM VALVE STYLE FACE PIPING



## INSTALLATION AND USER'S GUIDE

IMPORTANT SAFETY INSTRUCTIONS  
*READ AND FOLLOW ALL INSTRUCTIONS*  
SAVE THESE INSTRUCTIONS

# **TABLE OF CONTENTS**

<b>1</b>	<b>Principals of Operation.....</b>	<b>2</b>
1.1	Diaphragm Valve Operation	2
1.2	Single Tank Normal Operation	2
1.3	Single Tank During Backwash	3
1.4	Dual Tank Normal Filtration	3
1.5	Dual Tank During Backwash	3
<b>2</b>	<b>Face piping installation.....</b>	<b>3</b>
2.1	Single Tank Face Piping Installation (THS 3461)	4
2.2	Single Tank Face Piping Installation (THS 3484, THS4272, THS4284 and THS 4296)	9
2.3	Dual Tank Face Piping Installation (THS 3461)	12
2.4	Dual Tank Face Piping Installation (THS 3484, THS4272, THS 4284 and THS 4296)	15
<b>3</b>	<b>Backwash Controller Installation.....</b>	<b>19</b>
3.1	Semi-automatic Controller (CM200) - Single Tank Installation	19
3.2	Semi-Automatic Controller (CM200) – Dual Tank Installation	24
3.3	Automatic Controller (CA100) - Single Tank Installation	27
3.4	Automatic Controller (CA100) – Dual Tank Installation	31
3.5	Backwash Controller (CS400) - Single Tank Installation	35
3.6	Backwash Controller (CS400) - Dual Tank Installation	39
3.7	Operation (Semi-Automatic Controller)	43
<b>4</b>	<b>APPENDIX.....</b>	<b>47</b>
	APPENDIX A	48
	APPENDIX B	49
	APPENDIX C	50
	APPENDIX D	51

This manual covers installation and operating instructions for the optional diaphragm valve style face piping kits for use with the THS SERIES® FILTER VESSEL.

**⚠ WARNING**

This manual contains critical safety information that must be furnished to the end user. Failure to read and follow the instructions could result in serious personal injury and/or major property damage.

Thank you for purchasing the diaphragm valve style face piping kit for your THS SERIES FILTER VESSEL. They include features such as pneumatically actuated diaphragm valves, semi-automatic or automatic backwash controller options, and pre-glued construction for ease of assembly.

This manual covers the installation of face piping for both one and two tank filter systems, as well as installation of the semi-automatic and automatic controllers for the same. This manual also covers operation of the semi-automatic controller, as well as a trouble-shooting guide to assist with any problems which may occur during installation and operation. If you should have any questions pertaining to the filter tank itself, please refer to the separate manual provided for the tanks.

Please remember to use proper safety equipment and techniques when installing this filtration system.

## 1 Principals of Operation

This section will familiarize you with how the face piping kit and valves work in order to provide a means of backwashing the filter. It will cover how the diaphragm valves operate, the flow of water in a single tank system in normal filtration and backwash modes, and a dual tank system in normal filtration and backwash modes. **Please note that the diagrams are for reference only, and may not be representative of the actual face piping kit.**

### 1.1 Diaphragm Valve Operation

During normal operation water enters one side of the valve and exits the other. A shaft, which is attached to a diaphragm at one end, and a throttling cone and seal at the other, prevents water from flowing out of the sideport. When the valve is actuated, water is pumped into the top of the valve from the controller. This water and pressure causes the diaphragm to collapse onto the sealing surface of the valve body. This moves the cone portion of the shaft allowing water to exit out of the sideport, while sealing off flow from the influent side of the valve.

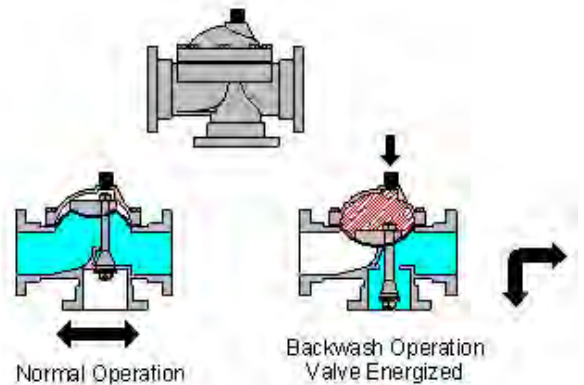

### 1.2 Single Tank Normal Operation

During normal filtration mode, water is passed through the influent piping and into the tank. Water is then passed through the sand, which is what actually filters the water. It is then passed through the collection laterals at the bottom of the tank. It then passes out of the effluent pipe and continues on through the rest of the filtration system.

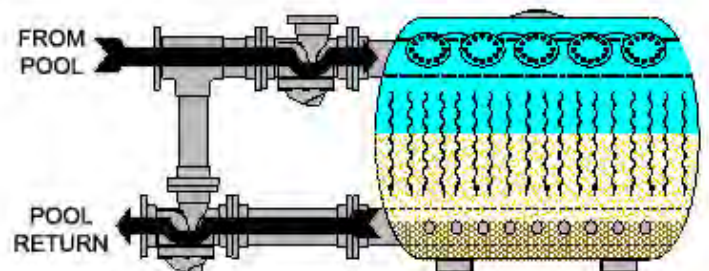

### 1.3 Single Tank During Backwash

During backwash mode, both of the diaphragm valves are actuated. Since water cannot enter the tank through the influent piping, it enters through the effluent piping. The water is pushed up through the sand bed, which is called "Fluidizing" the sand bed. This loosens dirt and debris trapped by the sand. This debris is then passed through the influent piping and exits through a waste pipe connected to the valve.

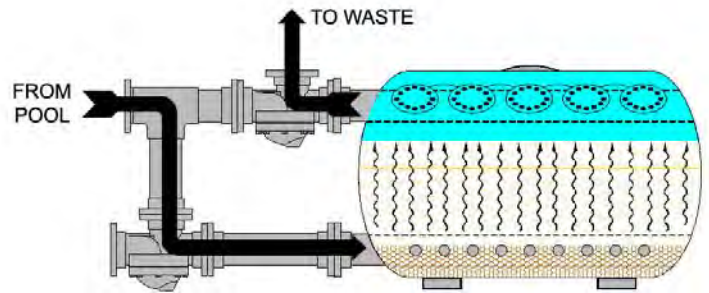

### 1.4 Dual Tank Normal Filtration

During normal filtration in a dual tank system, water is split between the two tanks. It passes through the influent piping and then through the sand beds. It is then passed through the collection laterals at the bottom of the tanks and passed out of the effluent piping and returned to the pool.

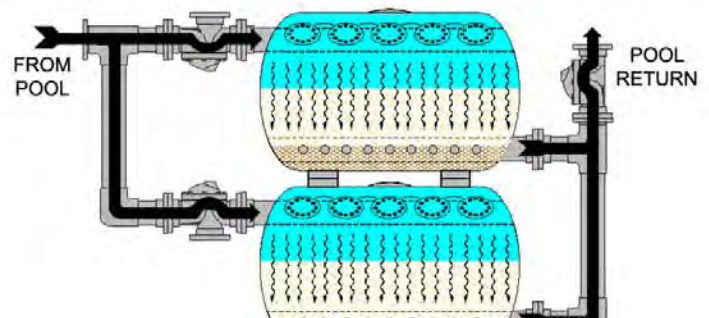

### 1.5 Dual Tank During Backwash

During backwash mode in a dual tank system, one of the three way valves and the two-way valve are actuated simultaneously. This allows water to pass through one of the filters as if it were filtering normally. When the water exits that tank, it is forced to enter the second tank through the effluent pipe. This water then backwashes the second tank. The dirt and debris is then passed through the influent pipe of tank two and out of a waste pipe connected to the valve.

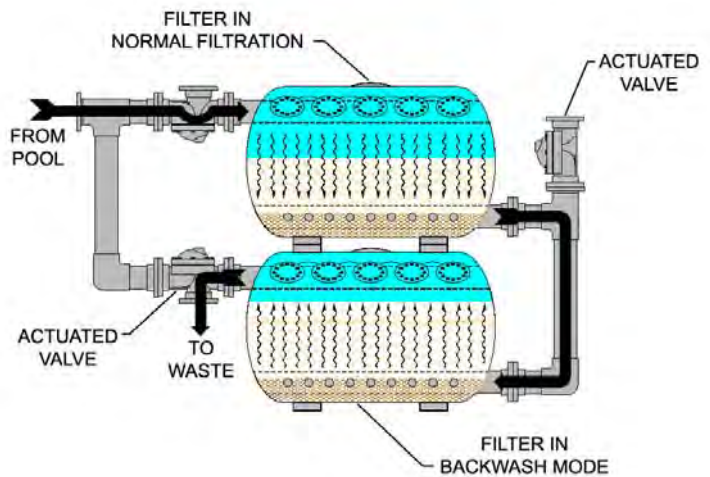

## 2 Face piping installation

**IMPORTANT:** Installation of the face piping should occur after the filter vessels have been positioned in their permanent location. Please refer to the Tank Owner's/Operator's Manual section on locating the filter vessels. For dual tank systems, it is very important that the "C-C" dimension listed in Figure 1 on page 5 of that manual is followed. Please refer to the Tank Owner/Operators Manual for more information.

Diaphragm valve style face piping kits come in either one or two tank kits. All piping is pre-glued, which means the only connections that need to be made are flanged connections (with the exception of THS3461 tanks which are 4" grooved connections) between mating sections. Please refer to the appropriate drawings in the Appendix section at the end of this manual for aid in assembly.

**IMPORTANT:** When tightening flange bolts, it is important to follow a diametrically opposed pattern. This will ensure that a proper seal between the flanges is obtained. Refer to Figure 1 below for proper tightening sequence. Torque all Metallic type bolts to a maximum of 25 ft-lbs / Non Metallic to a maximum of 15 ft-lbs/Non Metallic. Also, it may be beneficial to apply a lubricant to each bolt or nut to help relieve stress due to friction.

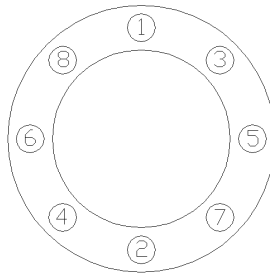

FIGURE 1

Prior to Installation see "Grooved Coupling Assembly Instruction" found on page 6.

## 2.1 Single Tank Face Piping Installation – THS 3461 (4" Grooved Connections)

The single tank face piping kit consists of:

- (1) V3-04A, 4" 3-way diaphragm valve without Flanges
- (1) V3-04B, 4" 3-way diaphragm valve with Flange, Thru port only.
- (1) Tee Assembly
- (1) Waste pipe extension
- (1) Backwash extension
- (1) Sightglass assembly (not shown)
- (7) 4" Grooved Coupling Assembly
- (3) 4" Flange gaskets
- (24) 4" 3/4-10 x 3 1/2" Zinc Plated Bolts
- (48) Flat Washer, Zinc Plated
- (24) Lock Washer, Zinc Plated
- (24) Hex Nut, 3/4-10, Zinc Plated
- (1) Semi-automatic backwash controller (See Controller Installation Section)

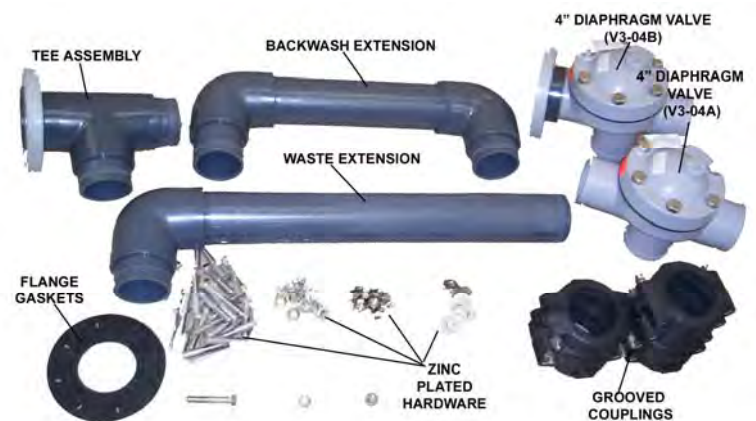

Verify that all parts listed above were supplied before beginning installation. Replacement parts can be ordered through your local distributor.

### Grooved Coupling Assembly Instruction

- 1) Seat rubber gasket over end of pipe 1, making sure that the gasket does not cover the groove cut in the pipe.
- 2) Insert end of pipe 2 into rubber gasket, again making sure that the gasket does not cover the groove in the pipe.
- 3) Fit coupling halves over rubber gasket making sure that coupling halves are seated into the grooves of the (2) pipes. Make sure one coupling half has standard thru bolt holes and the other has hexagonal counter-bored thru bolt holes.

Apply an anti-seize lubricant to the threads of the coupling bolts. Insert bolts into the holes in the coupling, making sure that the bolt heads fit inside the hexagonal counter-bored holes on one side of the coupling. Place one washer and nut on each bolt and tighten.

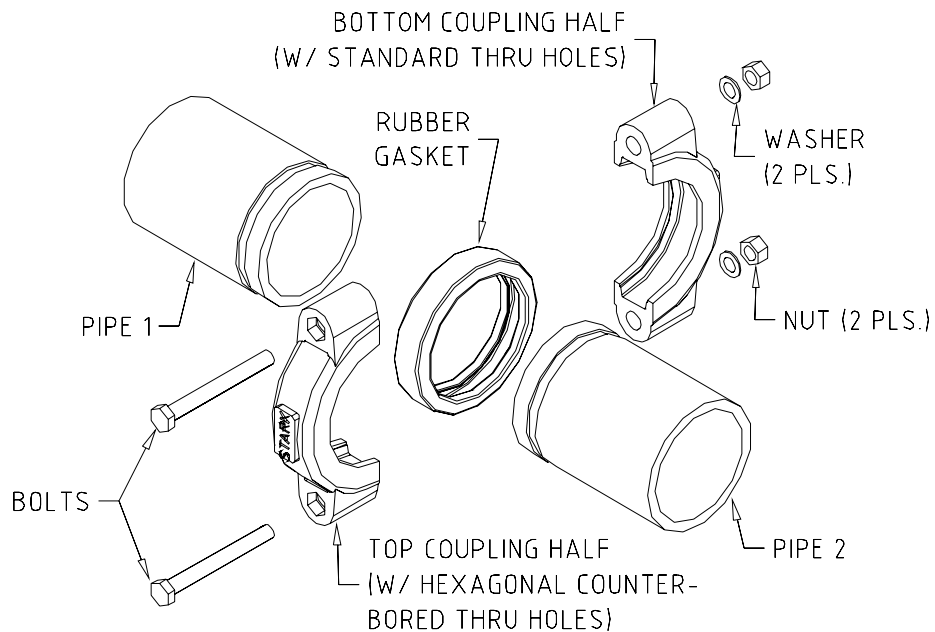



## STEP 1: 4" Valve Installation

Place a gasket of grooved coupling assembly on the influent and effluent tank grooved pipe connections. Place valve (V3-04A) with no flanges on influent grooved pipe connection, install groove coupling assembly (Refer to page 5). Place valve (V3-04B) with flange on thru port on effluent grooved pipe connection, install groove coupling assembly. See picture at right for proper orientation. Snug the nuts to "hand tight", but do not fully tighten. This will allow for adjustments during the remainder of the installation. Please note the orientation of the valves. **The arrows on the valve covers should be pointing toward the tank.**



## STEP 2: Tee Assembly Installation

Place gasket of grooved coupling assembly on top grooved connection of the influent valve. Install the Tee assembly on the top of the influent valve, and orient it as shown in picture, install groove coupling assembly. Snug the nuts to "hand tight", but do not fully tighten.



### STEP 3: Backwash Extension Installation

Place gasket of grooved coupling assembly on grooved connection of the Tee assembly along with the effluent valve. Install the backwash extension on to the system as shown in picture. It may be necessary to turn the valves or tee assembly slightly to ensure a proper fit. Install groove coupling assembly. Snug the nuts to “hand tight”, but do not fully tighten.



### STEP 4: Waste Extension Installation

Place gasket of grooved coupling assembly on grooved connection of influent valve. Install the waste extension on to the system as shown in picture. Install groove coupling assembly. Snug the nuts to “hand tight”, but do not fully tighten.





### STEP 5: Sightglass Installation

Assemble the sightglass by threading the glass portion into the threaded saddle on the spool. Be sure to use pipe thread sealant tape on the threads. Place gasket of grooved coupling assembly on to the waste extension. Install the sightglass assembly on to the waste flange. Orient the glass portion so it will be visible during operation. Install groove coupling assembly. Snug the nuts to "hand tight", but do not fully tighten.



### STEP 6: Final Adjustments

Once all piping is in place make any necessary adjustments and fully tighten all flange bolts. Be sure to follow the bolt tightening pattern explained at the beginning of Section 2.0. **Tighten all Metallic type bolts to a maximum of 25 ft-lbs / Non Metallic to a maximum of 15 ft-lbs / Non Metallic.**

**Note: All piping should be fully supported with adequate bracing and hangers to prevent damage from weight and vibration.**

### STEP 7: Backwash Controller Installation

If a semi-automatic backwash controller was purchased, please refer to Section 3.1 of this manual. If an automatic backwash controller was purchased, please refer to Section 3.3.

**NOTE: There will be extra gaskets and isoplast hardware. This is to join the remaining flanged connections of the filter system to any existing or new plumbing.**

## 2.2 Single Tank Face Piping Installation – THS 3484, THS4272, THS4284 and THS 4296 (6” Flange Connections)

The single tank face piping kit consists of:

- (2) 6” 3-way diaphragm valves
- (1) Waste pipe extension
- (2) Backwash extension
- (1) Sightglass assembly (not shown)
  - (3) 6” Flange gaskets
- (80) Isoplast bolts
- (80) Isoplast nuts
- (2) Semi-automatic backwash controller (See Controller Installation Section)

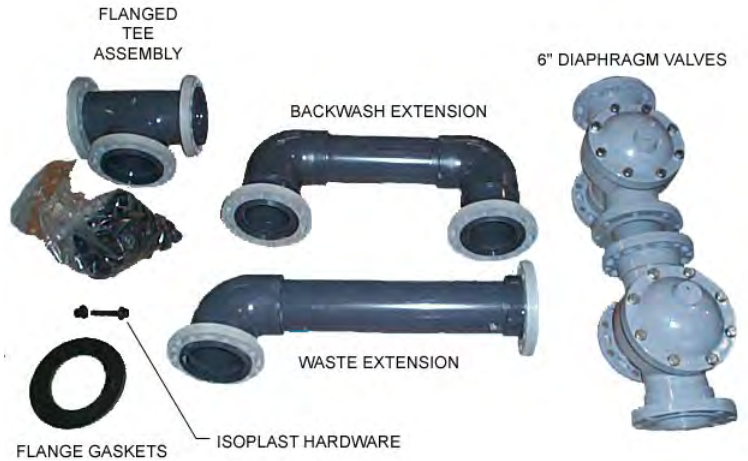

Verify that all parts listed above were supplied before beginning installation. Replacement parts can be ordered through your local distributor.

### STEP 1: 6” Valve Installation

Place a flange gasket on the influent and effluent tank flanges. Align the holes in the gasket with the holes in the flange ring on the tank. Place valves on the flanges aligning the holes on the valve flange with the tank flange ring. Please note the orientation of the valves. **The arrows on the valve covers should be pointing toward the tank.** Install isoplast bolts and nuts on the influent and effluent flanges. Snug the nuts to “hand tight”, but do not fully tighten. This will allow for adjustments during the remainder of the installation.

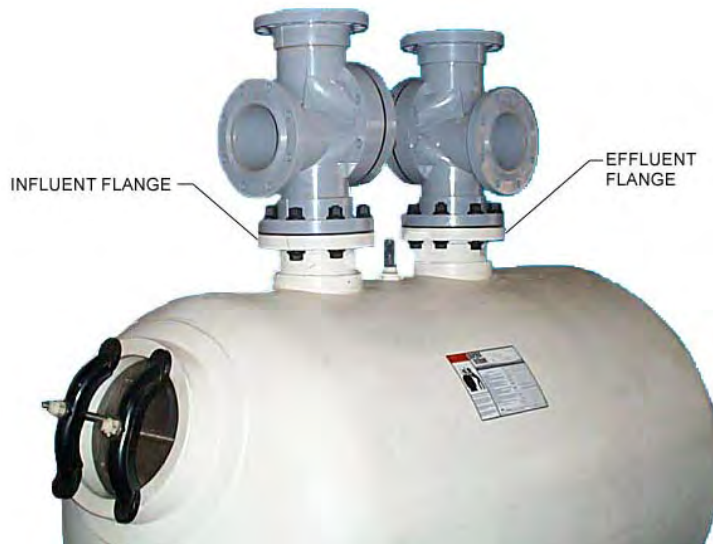

### STEP 2: Flanged Tee Assembly Installation

Place gasket on top flange of the influent valve. Install the flanged tee assembly on the top of the influent valve, and orient it as shown in picture. Install isoplast bolts and nuts. Snug the nuts to “hand tight”, but do not fully tighten.



### STEP 3: Backwash Extension Installation

Place isoplast bolts through the bolt holes on the backwash extension flanges, then place flange gaskets on to the flanges with the bolts. Install the backwash extension on to the system as shown in picture. It may be necessary to turn the valves or flanged tee assembly slightly to ensure a proper fit. Install isoplast nuts. Snug the nuts to “hand tight”, but do not fully tighten.



#### STEP 4: Waste Extension Installation

Place isoplast bolts through bolt holes on the waste extension flange (elbow side), then place a flange gasket onto the flange. Install waste extension onto valve making sure it is oriented properly with the flange on the elbow connecting to the valve (see picture). Install isoplast nuts. Snug the nuts to “hand tight”, but do not fully tighten.



#### STEP 5: Sightglass Installation

Assemble the sightglass by threading the glass portion into the threaded saddle on the spool. Be sure to use pipe thread sealant tape on the threads. Place isoplast bolts through flange on the waste header, then place a flange gasket on to the flange. Install the sightglass assembly on to the waste flange. Orient the glass portion so it will be visible during operation. Install isoplast nuts and snug them to “hand tight”, but do not fully tighten.



#### STEP 6: Final Adjustments

Once all piping is in place make any necessary adjustments and fully tighten all flange bolts. Be sure to follow the bolt tightening pattern explained at the beginning of Section 2.0. **Tighten all Metallic type bolts to a maximum of 25 ft-lbs / Non Metallic to a maximum of 15 ft-lbs / Non Metallic.**

**Note: All piping should be fully supported with adequate bracing and hangers to prevent damage from weight and vibration.**

#### STEP 7: Backwash Controller Installation

If a semi-automatic backwash controller was purchased, please refer to Section 3.1 of this manual. If an automatic backwash controller was purchased, please refer to Section 3.3.

**NOTE: There will be extra gaskets and isoplast hardware. This is to join the remaining flanged connections of the filter system to any existing or new plumbing.**

## 2.3 Dual Tank Face Piping Installation – THS 3461 (4" Grooved Tank Connections)

The two tank face piping kit consists of:

- (2) 4" 3-way diaphragm valves
- (1) 6" 2-way diaphragm valve
- (2) Influent/effluent headers
- (1) Waste header
- (1) Sightglass assembly (not shown)
- (4) 4" Grooved Coupling Assembly
- (2) 4" Flange gaskets
- (2) 6" Flange gaskets
- (24) Isoplast bolts
- (24) Isoplast nuts
- (16) 4" 3/4-10 x 3 1/2" Zinc Plated Bolts
- (32) Flat Washer, Zinc Plated
- (16) Lock Washer, Zinc Plated
- (16) Hex Nut, 3/4-10, Zinc Plated
- (1) Semi-automatic backwash controller (See Controller Installation Section)

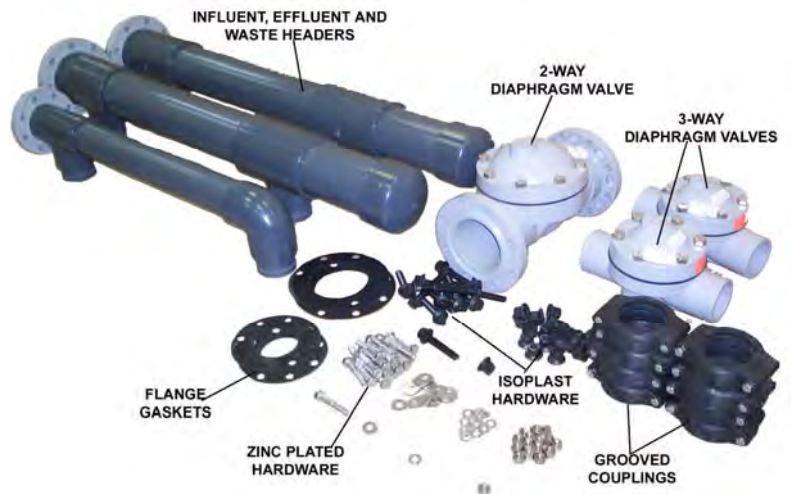

Verify that all parts listed above were supplied before beginning installation. Replacement parts can be ordered through your local distributor.

Prior to Installation see “Grooved Coupling Assembly Instruction” found on page 5.

**IMPORTANT:** Verify that the center to center dimension between the two tanks is correct. Refer to Figure 1 on page 5 of the Tank Owner’s/Operator’s Manual for more information.

### STEP 1: Level the tanks

Make sure influent and effluent flanges on each tank are level. Shimming may be required to bring the tanks to level with each other. Use a non-compressible material placed under the tank saddles. Further leveling may require the saddles to be adjusted. Please refer to page 5 of the Tank Owner’s/Operator’s Manual for more information.





## STEP 2: 4" 3-way Valve Installation

Place a gasket of grooved coupling assembly on the influent grooved pipe connection of each tank. Place valves on influent grooved pipe connections, install groove coupling assembly (Refer to page 5). See picture at right for proper orientation. Snug the nuts to "hand tight", but do not fully tighten. This will allow for adjustments during the remainder of the installation. Please note the orientation of the valves. **The arrows on the valve covers should be pointing toward the tank.**



## STEP 3: Influent/Effluent Header Installation

Place a gasket of grooved coupling assembly on top grooved connection of each valve and the effluent grooved pipe connection of each tank. Install headers on to the valve/tank connections (see pictures). Install groove coupling assembly. The headers can be installed with the terminating flange facing either left or right depending on what is needed for the application. Snug the nuts to "hand tight", but do not fully tighten. This will allow for adjustments during the remainder of the installation.





#### STEP 4: Waste Header Installation

Place gasket of grooved coupling assembly on grooved connection of influent valves. Install the waste extension on to the system as shown in picture. Install groove coupling assembly. Snug the nuts to “hand tight”, but do not fully tighten.



#### STEP 5: 6” 2-way Valve Installation

Place isoplast bolts through the flange on the effluent header, then place a flange gasket on to the flange. Install the valve on to the flanges making sure to align the flange holes with the bolts. **The arrow on the valve cover should be pointing away from the tank, in the direction of the effluent flow.** Install isoplast nuts. Snug the nuts to “hand tight”, but do not fully tighten.

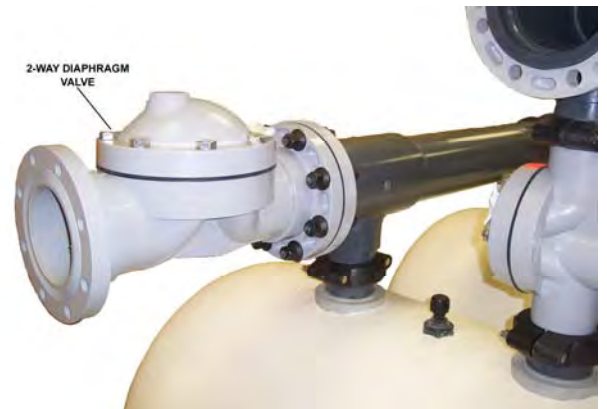

#### STEP 6: Sightglass Installation

Assemble the sightglass by threading the glass portion into the threaded saddle on the spool. Be sure to use pipe thread sealant tape on the threads. Place isoplast bolts through flange on the waste header, then place a flange gasket on to the flange. Install the sightglass assembly on to the waste flange. Orient the glass portion so it will be visible during operation. Install isoplast nuts and snug them to “hand tight”, but do not fully tighten.



## STEP 7: Final Adjustments

Once all piping is in place make any necessary adjustments and fully tighten all flange bolts. Be sure to follow the bolt tightening pattern explained at the beginning of Section 2.0. **Tighten all Metallic type bolts to a maximum of 25 ft-lbs / Non Metallic to a maximum of 15 ft-lbs / Non Metallic.**

**Note: All piping should be fully supported with adequate bracing and hangers to prevent damage from weight and vibration.**

## STEP 8: Backwash Controller Installation

If a semi-automatic backwash controller was purchased, please refer to Section 3.2 of this manual. If an automatic backwash controller was purchased, please refer to Section 3.4.

**NOTE: There will be extra gaskets and isoplast hardware. This is to join the remaining flanged connections of the filter system to any existing or new plumbing.**

## 2.4 Dual Tank Face Piping Installation – THS 3484, THS4272, THS 4284 and THS 4296 (6" Flange Connections)

The two tank face piping kit consists of:

- (2) 6" 3-way diaphragm valves
- (1) 6" 2-way diaphragm valve
- (2) Influent/effluent headers
- (1) Waste header
- (1) Sightglass assembly (not shown)
- (13) 6" Flange gaskets
- (104) Isoplast bolts
- (104) Isoplast nuts
- (2) Semi-automatic backwash controller  
(See Controller Installation Section)

Verify that all parts listed above were supplied before beginning installation. Replacement parts can be ordered through your local distributor.

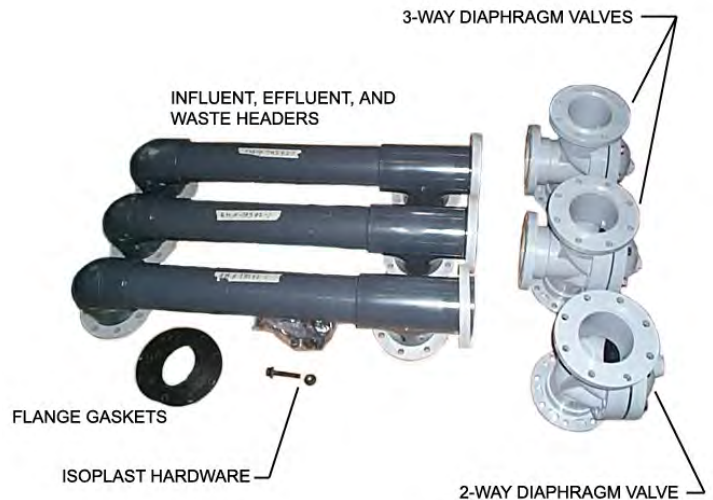

**IMPORTANT: Verify that the center to center dimension between the two tanks is correct. Refer to Figure 1 on page 5 of the Tank Owner's/Operator's Manual for more information.**

### STEP 1: Level the tanks

Make sure influent and effluent flanges on each tank are level. Shimming may be required to bring the tanks to level with each other. Use a non-compressible material placed under the tank saddles. Further leveling may require the saddles to be adjusted. Please refer to page 5 of the Tank



Owner's/Operator's Manual for more information.

### STEP 2: 6" 3-way Valve Installation

Place a flange gasket on the influent flange of each tank. Align the holes in the gasket with the holes in the flange on the tank. Place valves on the influent flanges aligning the holes on the valve flange with the tank flange. Please note the orientation of the valves. **The arrows on the valve covers should be pointing toward the tank.** Install isoplast bolts and nuts on the influent flanges of each tank. Snug the nuts to "hand tight", but do not fully tighten. This will allow for adjustments during the remainder of the installation



### STEP 3: Influent/Effluent Header Installation

Place flange gaskets on the top flanges of the valves and on the effluent flanges of the tanks. Align the holes in the gaskets with the holes in the flanges. Install headers on to the valve/tank flanges (see picture). The headers can be installed with the terminating flange facing either left or right depending on what is needed for the application. Install isoplast bolts and nuts on the flanges of the headers. Snug the nuts to "hand tight", but do not fully tighten.



#### STEP 4: Waste Header Installation

Place isoplast bolts through the flanges on the waste header, then place flange gaskets on to the flanges with the bolts. Install the waste header on to the remaining valve flanges making sure to align the flange holes with the bolts. It may be necessary to turn the valves slightly to ensure a proper fit. Install isoplast nuts. Snug the nuts to “hand tight”, but do not fully tighten.



#### STEP 5: 6” 2-way Valve Installation

Place isoplast bolts through the flange on the effluent header, then place a flange gasket on to the flange. Install the valve on to the flanges making sure to align the flange holes with the bolts. **The arrow on the valve cover should be pointing away from the tank, in the direction of the effluent flow.** Install isoplast nuts. Snug the nuts to “hand tight”, but do not fully tighten.



#### STEP 6: Sightglass Installation

Assemble the sightglass by threading the glass portion into the threaded saddle on the spool. Be sure to use pipe thread sealant tape on the threads. Place isoplast bolts through flange on the waste header, then place a flange gasket on to the flange. Install the sightglass assembly on to the waste flange. Orient the glass portion so it will be visible during operation. Install isoplast nuts and snug them to “hand tight”, but do not fully tighten.



### **STEP 7: Final Adjustments**

Once all piping is in place make any necessary adjustments and fully tighten all flange bolts. Be sure to follow the bolt tightening pattern explained at the beginning of Section 2.0. **Tighten all Metallic type bolts to a maximum of 25 ft-lbs / Non Metallic to a maximum of 15 ft-lbs / Non Metallic.**

### **STEP 8: Backwash Controller Installation**

If a semi-automatic backwash controller was purchased, please refer to Section 3.2 of this manual. If an automatic backwash controller was purchased, please refer to Section 3.4.

**NOTE: There will be extra gaskets and isoplast hardware. This is to join the remaining flanged connections of the filter system to any existing or new plumbing.**



### 3 Backwash Controller Installation

**NOTE:** This section covers the installation of semi-automatic and automatic backwash controllers for single tank and dual tank systems.

#### 3.1 Semi-automatic Controller (CM200) - Single Tank Installation

The single tank semi-automatic controller kit consists of the following:

- (1) Controller gauge panel
- (2) 3/8" OD tube quick connect tees
- (3) 3/8" OD x 1/4" MNPT quick connect fittings
- (1) Check valve w/ fittings
- (100 ft) 3/8" OD polyethylene tube



Semi-automatic controllers may be mounted 1 of 2 ways and is system specific. Mounting methods are "pipe mounted" or "flange mounted". For pipe mounted systems, verify the mounting accessories shown below and refer to steps 1 and 2A for installation. For flange mounted systems, refer to step 2B for installation.

Pipe mounting accessories (system specific):

- (2 pr.) \*Mounting brackets and hardware
- (2) Controller supports
- (2) Isoplast bolts
- (2) Isoplast nuts

\* Mounting brackets will vary based on the filter system being used. Brackets supplied will fit typical waste pipe size of 6". Please note that Brackets are available for 4" or 8" pipe diameter. If required, these can be ordered through a Stark distributor.

Verify that all parts listed above were supplied before beginning installation. Replacement parts can be ordered through a Stark distributor.

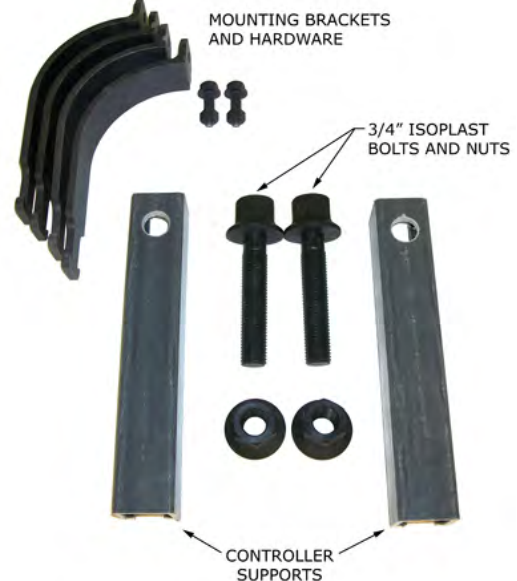



### STEP 1: Controller Support Assembly

Attach controller supports to the gauge panel assembly using the  $\frac{3}{4}$ " isoplast nuts and bolts. Attach so the channel side of the supports is away from the gauge panel. Tighten bolts, but do not over tighten, as this may crack the face of the gauge panel.

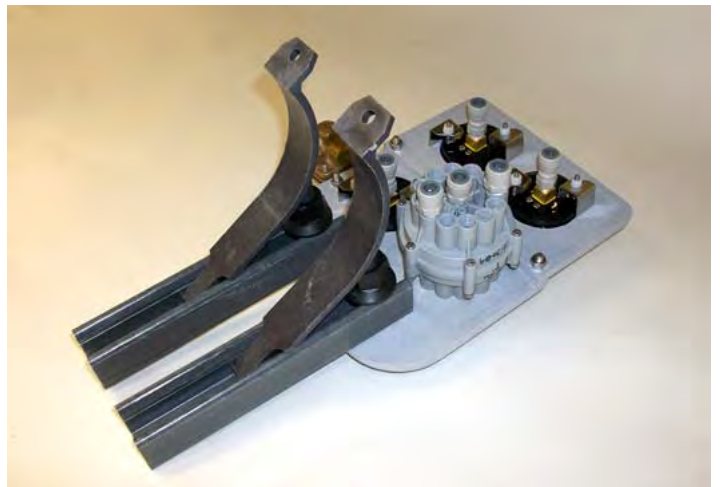

### STEP 2A: Attach Gauge Panel to Pipe

Insert notched end of pipe clamps into the channel of the controller supports. Attach the gauge panel assembly to the waste extension (see picture). Slide remaining pipe clamps into the channels of the controller supports. Use the nuts and bolts supplied to tighten the clamps on to the pipe.



### STEP 2B: Attach Gauge Panel to Flange

Attach the gauge panel assembly to flange (see picture). Insert isoplast bolts through the bottom holes of the gauge panel and top holes of the flange. Use the isoplast nuts to tighten in place.

\*\*Please note that the setup shown is for a 6" flanged connection. The flange connection plate may be modified for use on a 4" or 8" flanged connection.



### STEP 3: Installation of Controller Tubing

Connect length of tubing from supply source (water or compressed air) to the inlet side of the regulator. **Please note, the water source must be able to supply water at a pressure of 35 psi minimum.**

Connect length of tubing from the outlet side of the regulator to the inlet end of the check valve. Please note the direction of the flow arrow on the check valve. It should be pointing away from the regulator.

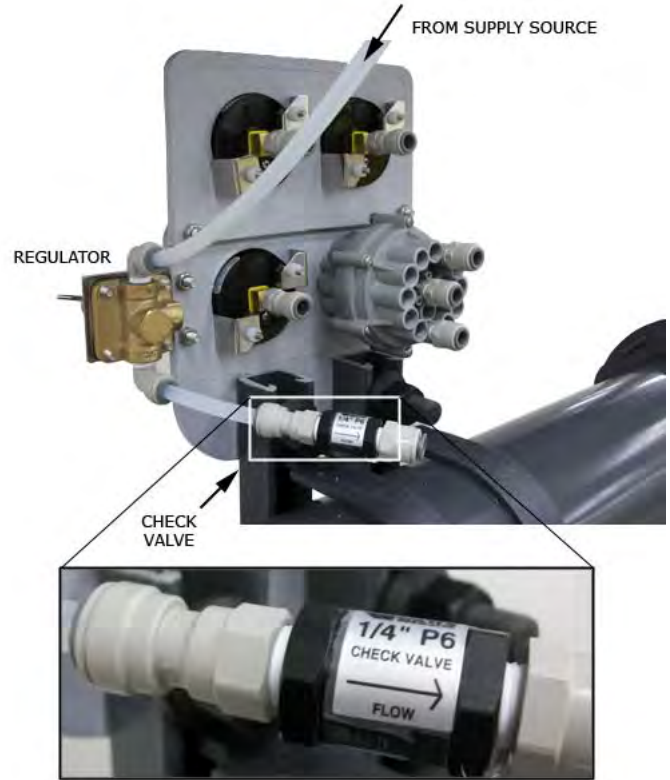

Connect length of tubing to open end of the check valve. Connect quick connect tee to end of tube.

Connect tubes from the quick connect tee to back of the gauge panel assembly as shown in picture. One end should be connected to the center fitting on the multiport valve. The other end should be connected to the multiport pressure gauge.

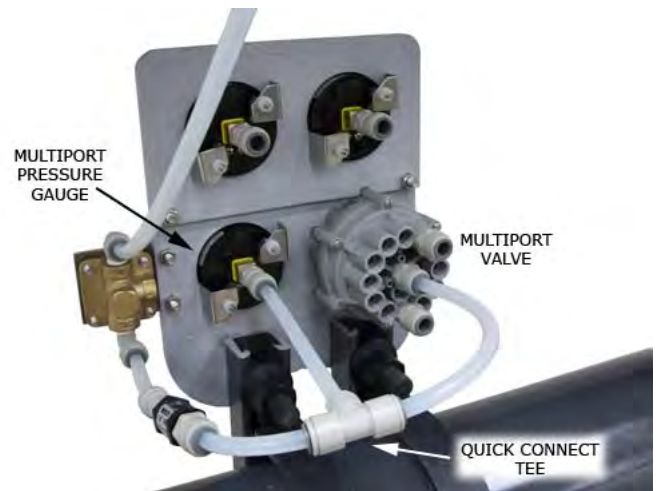

Drill and tap for ¼" NPT hole on the influent and effluent pipes from the filter system (see schematic diagram in Appendix B). Install quick connect fittings into pipe. Be sure to use pipe thread sealant tape on the threads. Install 3/8" OD tube from fittings to rear of the gauge panel assembly. Connect tubes into correct gauge on the rear of the panel (see picture).

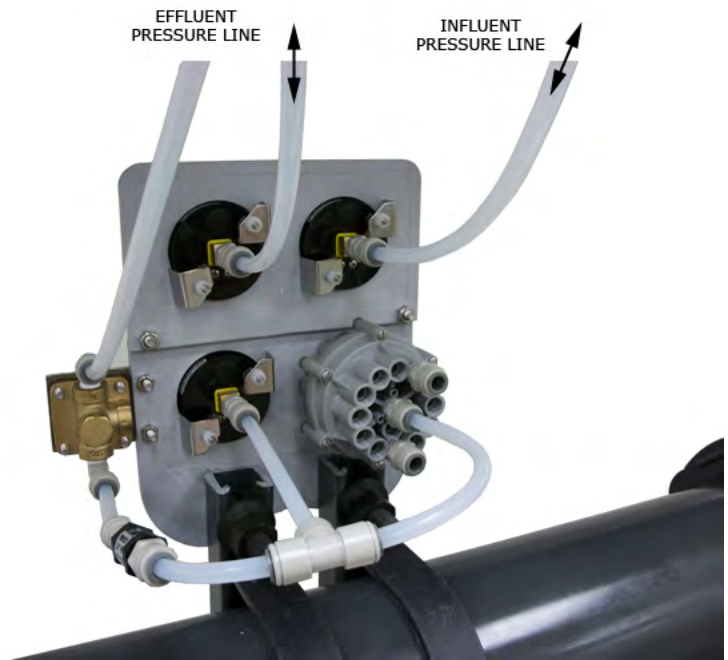

Connect lengths of tubing into the quick connect fittings on top of the valve cover. Join these two tubes with a quick connect tee as shown in the picture.

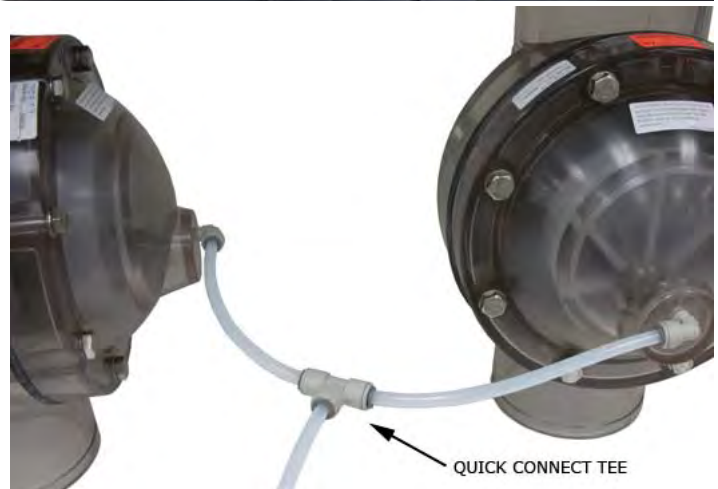

Connect a length of tube from the open end of the quick connect tee from the valves to the fitting on the back of the gauge panel assembly as shown in the picture. Connect tube from remaining quick connect fitting and connect to drain.

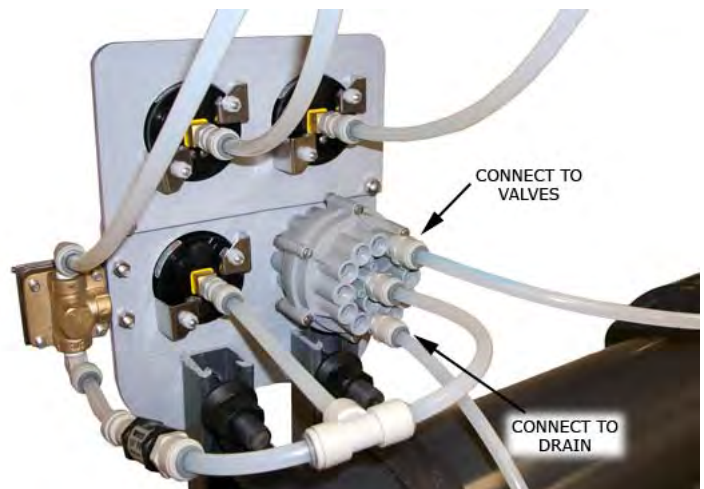

This completes the installation of the semi-automatic backwash controller for single tank systems. Please proceed to Section 2.6 for operating instructions.



### 3.2 Semi-Automatic Controller (CM200) – Dual Tank Installation

The dual tank semi-automatic controller kit consists of the following:

- (1) Controller gauge panel
- (3) 3/8" OD tube quick connect tees
- (3) 3/8" OD x 1/4" MNPT quick connect fittings
- (1) Check valve w/ fittings
- (1) And/Or Valve
- (100 ft) 3/8" OD polyethylene tube



Please refer to steps 1 & 2 of "Semi-Automatic Controller (CM200) – Single Tank Installation" for mounting of the gauge panel assembly to the filter system.

### STEP 3: Installation of Controller Tubing

Connect length of tubing from supply source (water or compressed air) to the inlet side of the regulator. **Please note, the water source must be able to supply water at a pressure of 35 psi minimum.**

Connect length of tubing from the outlet side of the regulator to the inlet end of the check valve. Please note the direction of the flow arrow on the check valve. It should be pointing away from the regulator.

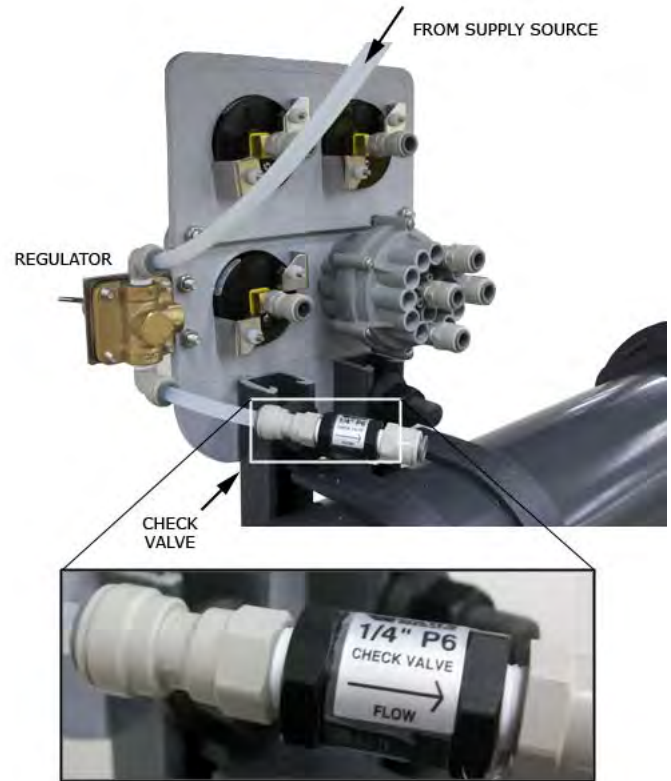

Connect length of tubing to open end of the check valve. Connect quick connect tee to end of tube.

Connect tubes from the quick connect tee to back of the gauge panel assembly as shown in picture. One end should be connected to the center fitting on the multiport valve. The other end should be connected to the multiport pressure gauge





Drill and tap for ¼" NPT hole on the influent and effluent pipes from the filter system (see schematic diagram in Appendix B). Install quick connect fittings into pipe. Be sure to use pipe thread sealant tape on the threads. Install 3/8" OD tube from fittings to rear of the gauge panel assembly. Connect tubes into correct gauge on the rear of the panel (see picture).

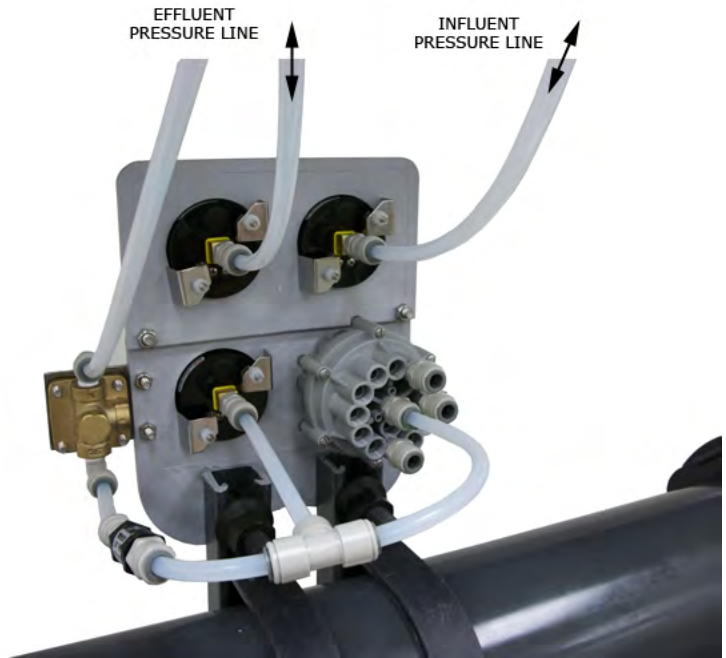

Assemble the And/Or assembly shown in the picture. Be sure to leave enough tubing to reach all of the necessary connections. Connect all tubes to their appropriate locations as explained in the picture.

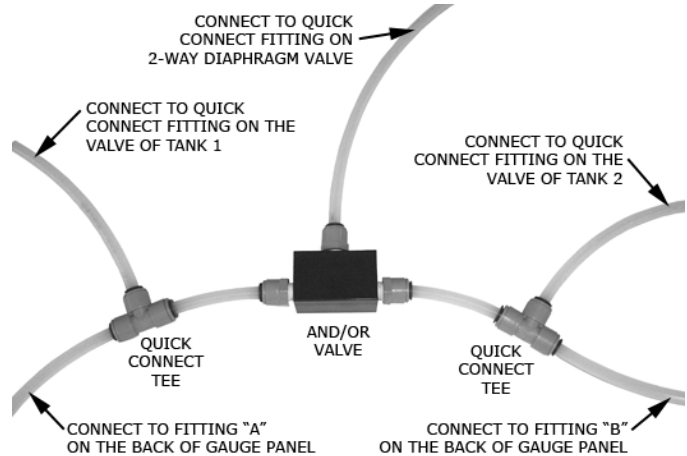

Connect tubes into respective fittings on gauge panel assembly. Connect a tube from remaining quick connect fitting and connect to drain.

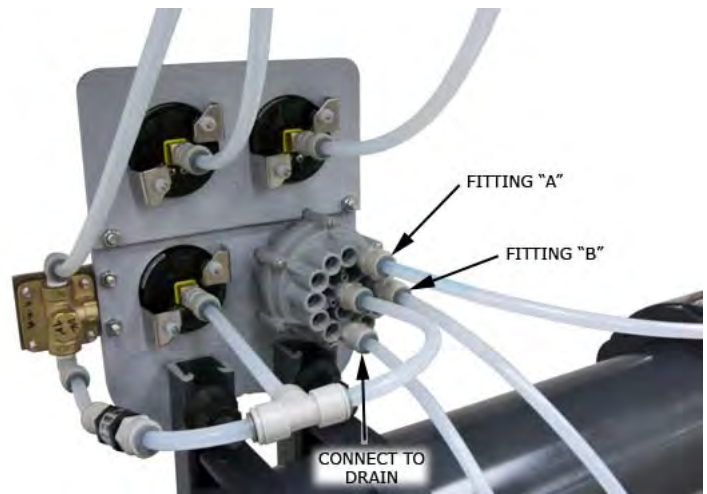

This completes the installation of the semi-automatic backwash controller for dual tank systems. Please proceed to Section 2.6 for operating instructions.

### 3.3 Automatic Controller (CA100) - Single Tank Installation

The single tank automatic controller kit consists of the following:

- (1) Automatic controller enclosure
- (1) Multiport valve enclosure
- (4) 3/8" OD tube quick connect tees
- (3) 3/8" OD x 1/4" MNPT quick connect fittings
- (1) Check valve w/ fittings
- (100 ft) 3/8" OD polyethylene tube
- (4pr.) Mounting brackets and hardware
- (1) Owner's/Operator's manual for automatic controller



Verify that all parts listed above were supplied before beginning installation. Replacement parts can be ordered through a Stark distributor.

## STEP 1: Attach Controller/Multiport Enclosures to Piping

Insert notched end of pipe clamps into the channel of the enclosure supports. Attach the enclosure assemblies to the waste extension (see picture). Slide remaining pipe clamps into the channels of the enclosure supports. Use the nuts and bolts supplied to tighten the clamps on to the pipe.

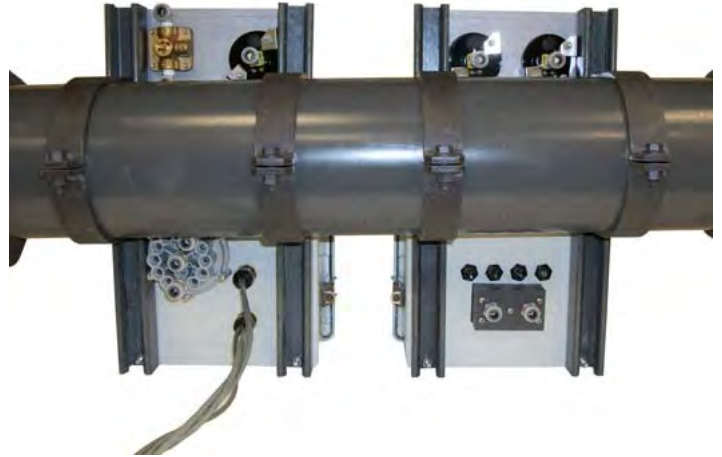

## STEP 2: Installation of Controller Tubing

Insert a length of 3/8" tube into top fitting on the regulator (see picture). Connect other end of this tube to your supply source (water or compressed air). An extra 3/8" x 1/4" MNPT fitting has been provided for connection. **Please note, the water source must be able to supply water at a pressure of 35 psi minimum.** Connect the check valve to the other fitting from the regulator with a small length of tubing. Make sure that the arrow on the check valve is pointed away from the regulator. From the other end of the check valve, connect a length of tube and attach a quick connect tee fitting (see picture).

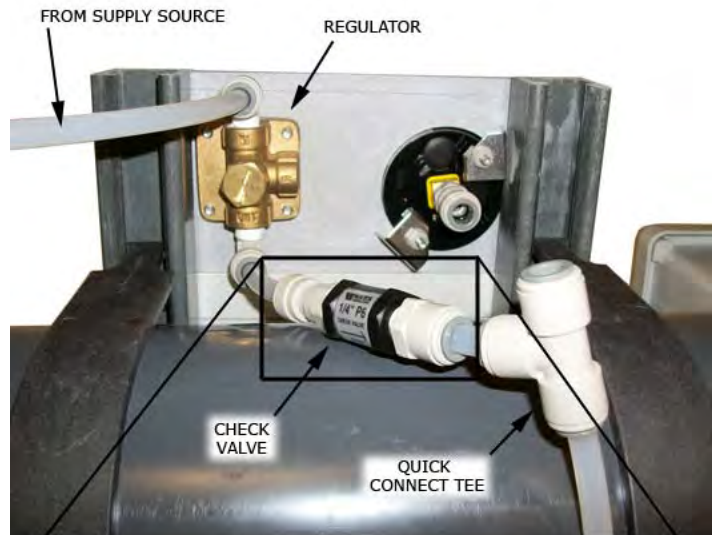

Connect tubes to each side of the quick connect tee. Connect one tube to the multiport pressure gauge and the other to the center fitting on the multiport valve (see picture).

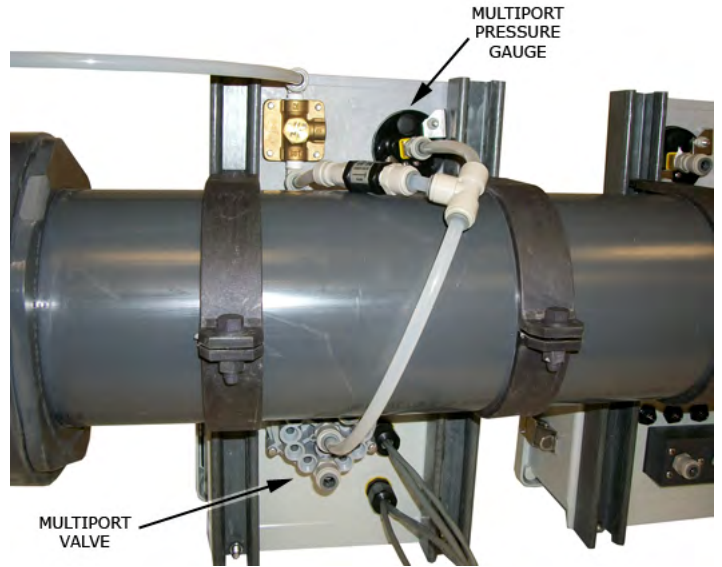

Drill and tap for 1/4" NPT hole on the influent and effluent pipes from the filter system (see schematic diagram in Appendix B). Install quick connect fittings into holes. Be sure to use pipe thread sealant tape on the threads. Install into each fitting a length of 3/8" OD tubing. Connect a quick connect tee on to the other end of each tube. Connect two smaller pieces of tubing into each end of the tee and connect to the rear of the automatic controller enclosure as shown.

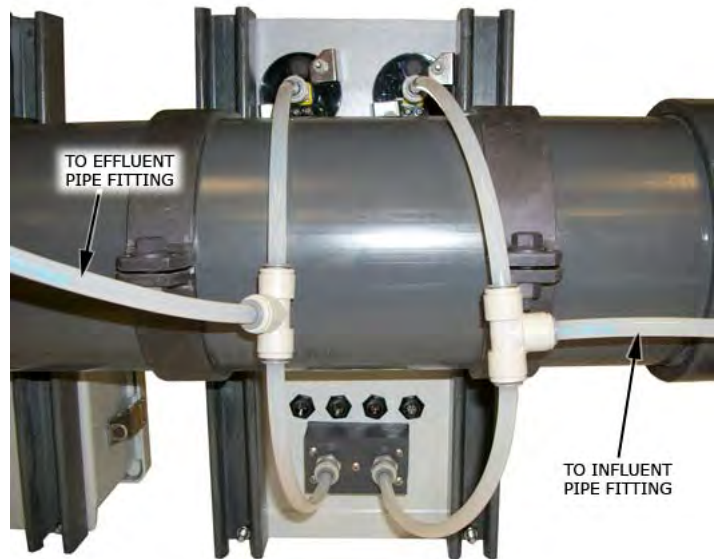

Connect lengths of tubing into the quick connect fittings on top of the valve cover. Join the two tubes with a quick connect tee as shown in the picture.

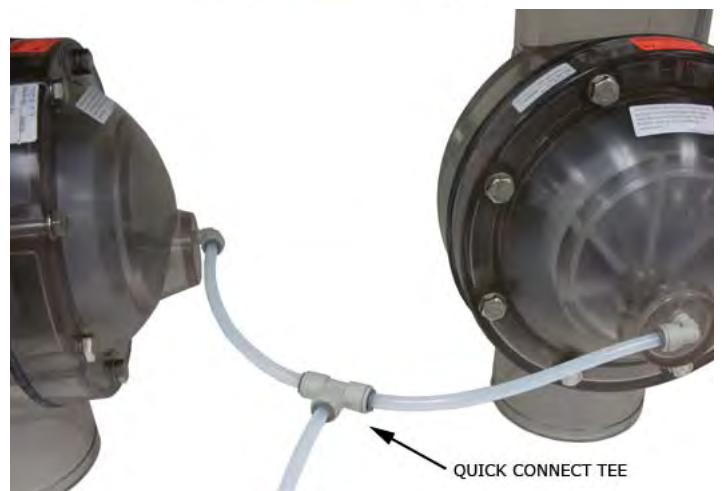



Connect a length of tube from the open end of the quick connect tee from the valves to the fitting on the back of the multiport valve enclosure as shown in the picture. Connect tube from remaining quick connect fitting and connect to drain.

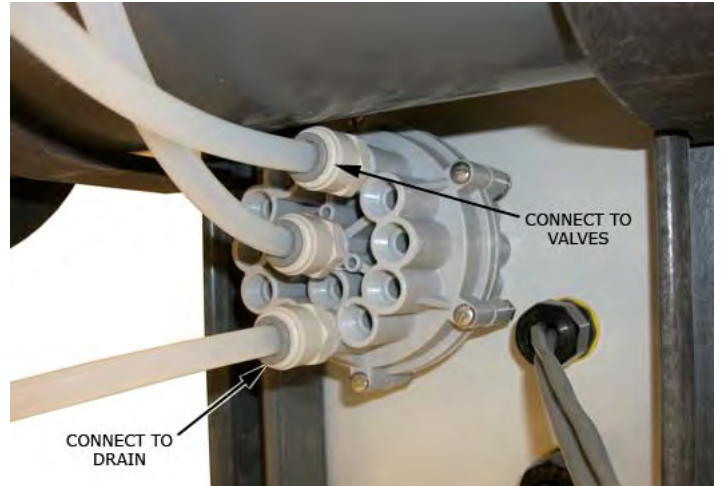

Connect the four wires from the rear of the multiport valve enclosure to the rear of the automatic controller enclosure. Each wire has a different style pin connector and can only connect to one of the sockets on the back of the automatic controller enclosure.



This completes the installation of the automatic backwash controller for single tank systems. Please see Owner's/Operator's Manual for automatic controller set up and operation.



### 3.4 Automatic Controller (CA100) – Dual Tank Installation

The dual tank automatic controller kit consists of the following:

- (1) Automatic controller enclosure
- (1) Multiport valve enclosure
- (5) 3/8" OD tube quick connect tees
- (3) 3/8" OD x 1/4" MNPT quick connect fittings
- (1) And/Or Valve
- (1) Check valve w/ fittings
- (100 ft) 3/8" OD polyethylene tube
- (4pr.) Mounting brackets and hardware
- (1) Owner's/Operator's manual for automatic controller



Verify that all parts listed above were supplied before beginning installation. Replacement parts can be ordered through a Stark distributor.

## STEP 1: Attach Controller/Multiport Enclosures to Piping

Insert notched end of pipe clamps into the channel of the enclosure supports. Attach the enclosure assemblies to the waste extension (see picture). Slide remaining pipe clamps into the channels of the enclosure supports. Use the nuts and bolts supplied to tighten the clamps on to the pipe.

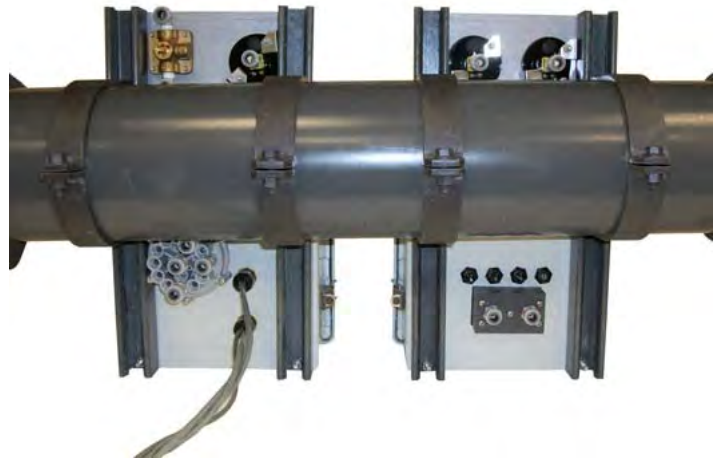

## STEP 2: Installation of Controller Tubing

Insert a length of 3/8" tube into top fitting on the regulator (see picture). Connect other end of this tube to your supply source (water or compressed air). An extra 3/8" x 1/4" MNPT fitting has been provided for connection. **Please note, the water source must be able to supply water at a pressure of 35 psi minimum.** Connect the check valve to the other fitting from the regulator with a small length of tubing. Make sure that the arrow on the check valve is pointed away from the regulator. From the other end of the check valve, connect a length of tube and attach a quick connect tee fitting (see picture).

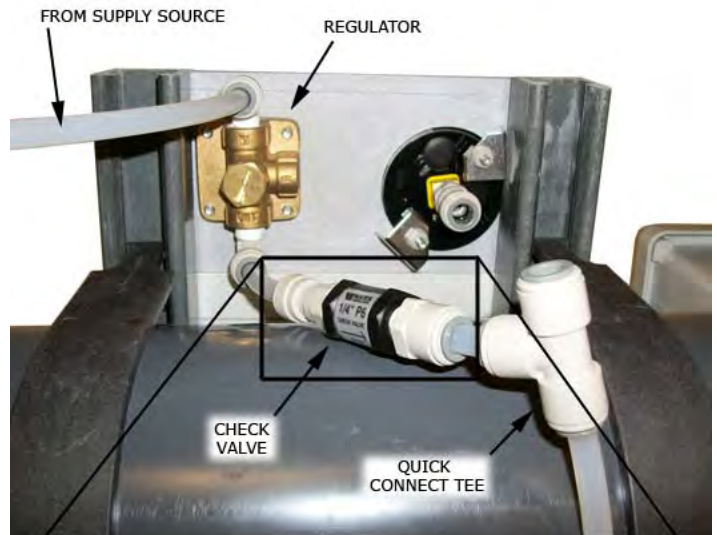

Connect tubes to each side of the quick connect tee. Connect one tube to the multiport pressure gauge and the other to the center fitting on the multiport valve (see picture).

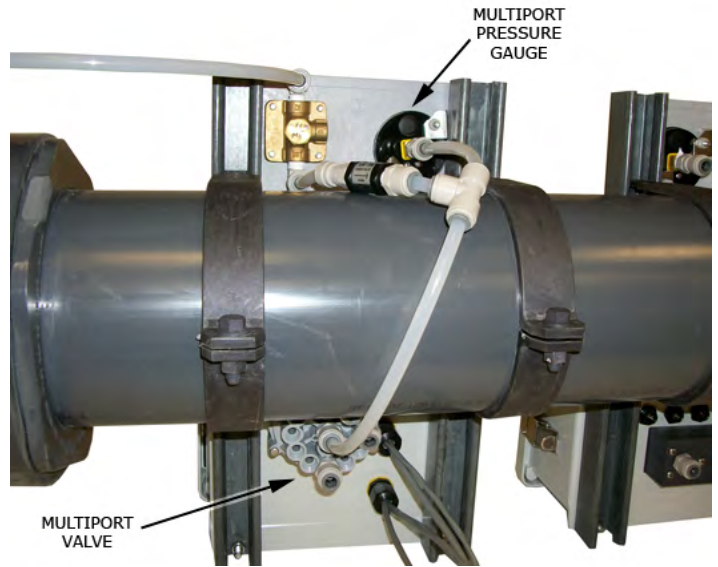

Drill and tap for 1/4" NPT hole on the influent and effluent pipes from the filter system (see schematic diagram in Appendix B). Install quick connect fittings into holes. **Be sure to use pipe thread sealant tape on the threads.** Install into each fitting a length of 3/8" OD tubing. Connect a quick connect tee on to the other end of each tube. Connect two smaller pieces of tubing into each end of the tee and connect to the rear of the automatic controller enclosure as shown.

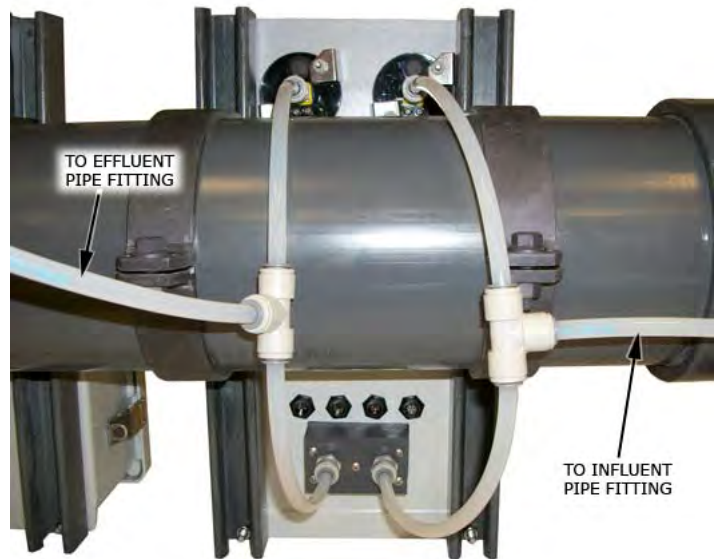

Assemble the And/Or assembly shown in the picture. Be sure to leave enough tubing to reach all of the necessary connections. Connect all tubes to their appropriate locations as explained in the picture.

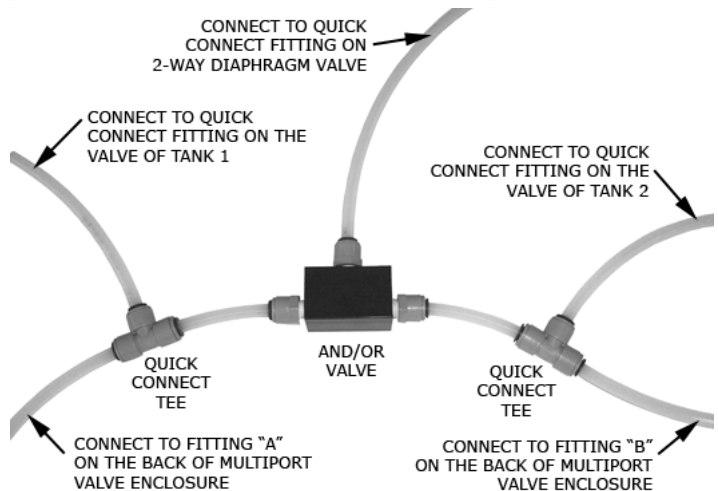

Connect tubes into respective fittings on the back of the multiport valve enclosure. Connect a tube from remaining quick connect fitting and connect to drain.

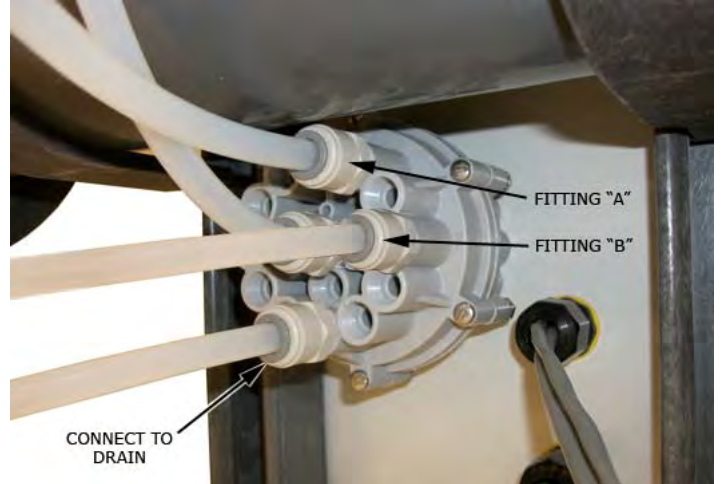

Connect the four wires from the rear of the multiport valve enclosure to the rear of the automatic controller enclosure. Each wire has a different style pin connector and can only connect to one of the sockets on the back of the automatic controller enclosure.



This completes the installation of the automatic backwash controller for dual tank systems. Please see Owner's/Operator's Manual for automatic controller set up and operation.

### 3.5 Backwash Controller (CS400) - Single Tank Installation

The single tank backwash controller kit (CS400) consists of the following:

- (1) CS400 backwash controller enclosure
- (2) 3/8" OD tube quick connect tees
- (3) 3/8" OD x 1/4" MNPT quick connect fittings
- (1) Check valve w/ fittings
- (100 ft) 3/8" OD polyethylene tube (2pr.) Mounting brackets and hardware
- (1) Owner's/Operator's manual for CS400 backwash controller



Verify that all parts listed above were supplied before beginning installation. Replacement parts can be ordered through a Stark distributor.



## STEP 1: Attach Controller/Multiport Enclosures to Piping

Insert notched end of pipe clamps into the channel of the backwash controller enclosure support. Attach the backwasher controller enclosure to the waste extension (see picture). Slide remaining pipe clamps into the channels of the enclosure support. Use the nuts and bolts supplied to tighten the clamps on to the pipe.



## STEP 2: Installation of Controller Tubing

Insert a length of 3/8" tube into top fitting on the regulator (see picture). Connect other end of this tube to your supply source (water or compressed air). An extra 3/8" x 1/4" MNPT fitting has been provided for connection. **Please note, the water source must be able to supply water at a pressure of 35 psi minimum.** Connect the check valve to the other fitting from the regulator with a small length of tubing. Make sure that the arrow on the check valve is pointed away from the regulator. From the other end of the check valve, connect a length of tube and attach a quick connect tee fitting (see picture).

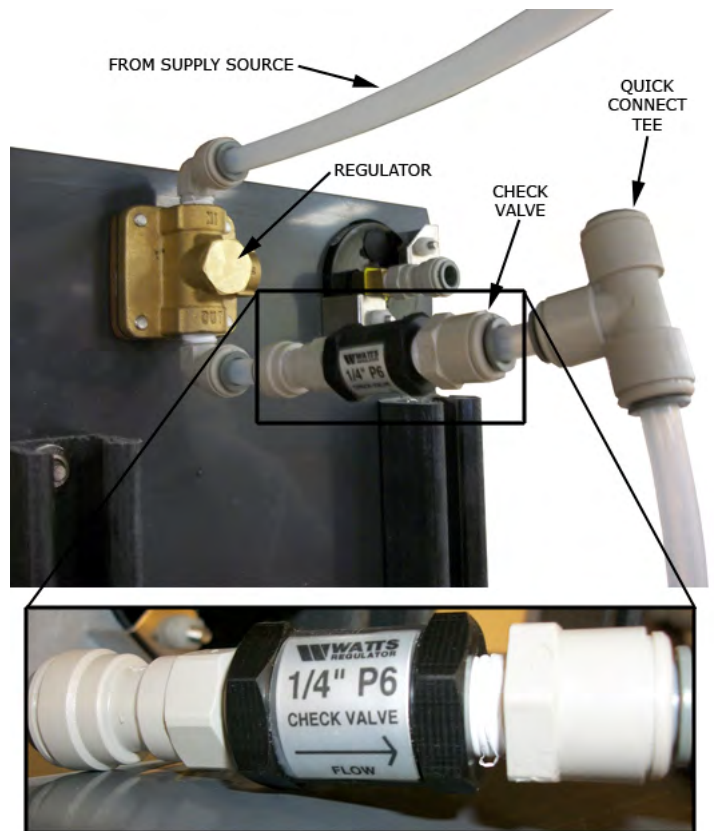

Connect tubes to each side of the quick connect tee. Connect one tube to the multiport pressure gauge and the other to the center fitting on the multiport valve (see picture).

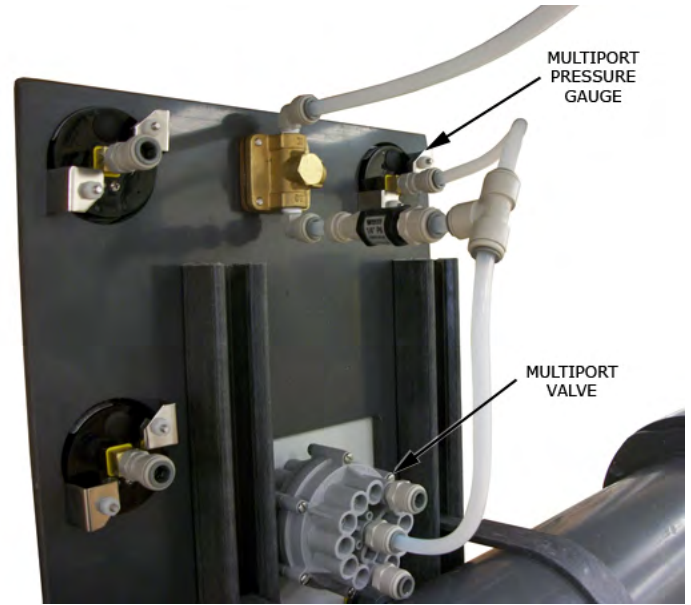

Drill and tap for 1/4" NPT hole on the influent and effluent pipes from the filter system (see schematic diagram in Appendix B). Install quick connect fittings into pipe. Be sure to use pipe thread sealant tape on the threads. Install 3/8" OD tube from fittings to rear of the gauge panel assembly. Connect tubes into correct gauge on the rear of the panel (see picture).

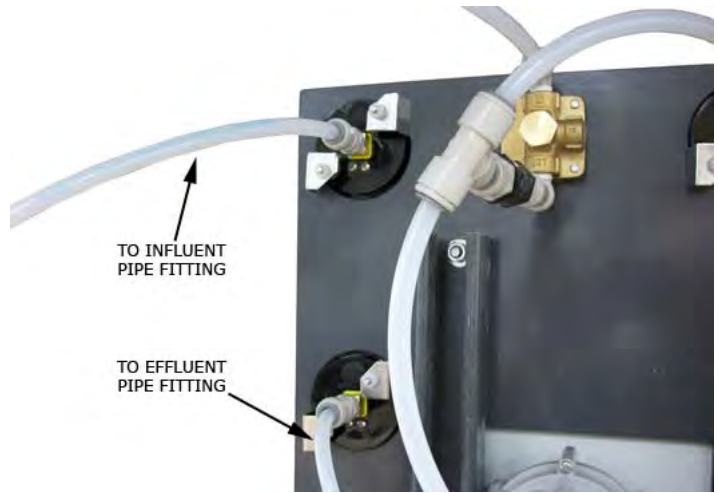

Connect lengths of tubing into the quick connect fittings on top of the valve cover. Join the two tubes with a quick connect tee as shown in the picture.

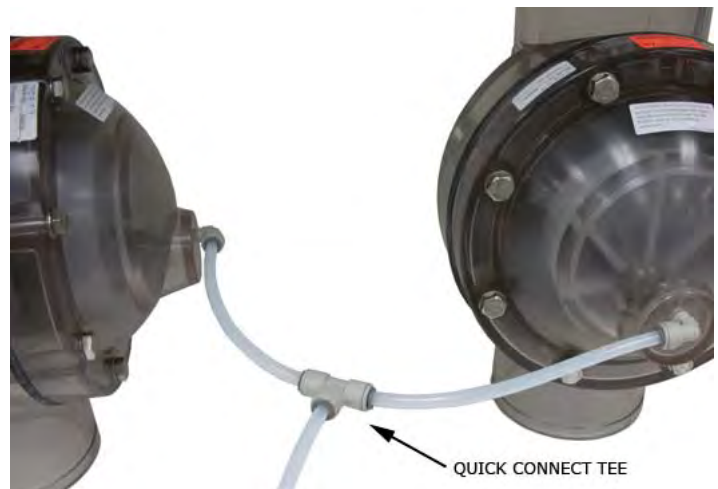

Connect a length of tube from the open end of the quick connect tee from the valves to the fitting on the back of the backwash controller enclosure as shown in the picture. Connect tube from remaining quick connect fitting and connect to drain.

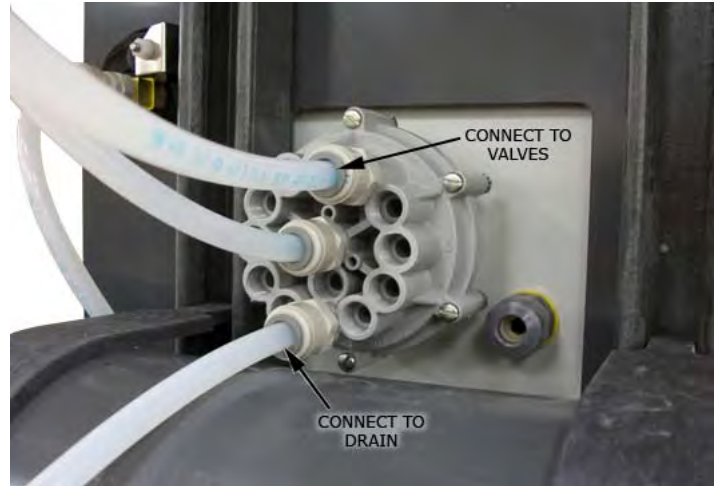

This completes the installation of the backwash controller (CS400) for single tank systems. Please see Owner's/Operator's Manual for backwash controller set up and operation.

### 3.6 Backwash Controller (CS400) - Dual Tank Installation

The dual tank backwash controller kit (CS400) consists of the following:

- (1) CS400 backwash controller enclosure
- (3) 3/8" OD tube quick connect tees
- (3) 3/8" OD x 1/4" MNPT quick connect fittings
- (1) Check valve w/ fittings
- (1) And/Or Valve
- (100 ft) 3/8" OD polyethylene tube (2pr.) Mounting brackets and hardware
- (1) Owner's/Operator's manual for CS400 backwash controller



Verify that all parts listed above were supplied before beginning installation. Replacement parts can be ordered through a Stark distributor.

## STEP 1: Attach Controller/Multiport Enclosures to Piping

Insert notched end of pipe clamps into the channel of the backwash controller enclosure support. Attach the backwasher controller enclosure to the waste extension (see picture). Slide remaining pipe clamps into the channels of the enclosure support. Use the nuts and bolts supplied to tighten the clamps on to the pipe.



## STEP 2: Installation of Controller Tubing

Insert a length of 3/8" tube into top fitting on the regulator (see picture). Connect other end of this tube to your supply source (water or compressed air). An extra 3/8" x 1/4" MNPT fitting has been provided for connection. **Please note, the water source must be able to supply water at a pressure of 35 psi minimum.** Connect the check valve to the other fitting from the regulator with a small length of tubing. Make sure that the arrow on the check valve is pointed away from the regulator. From the other end of the check valve, connect a length of tube and attach a quick connect tee fitting (see picture).

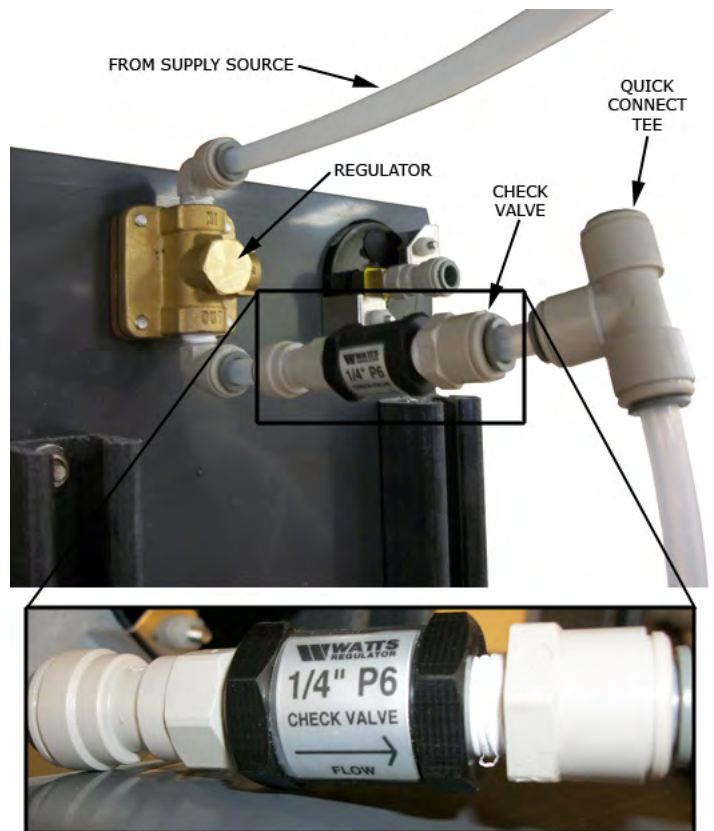



Connect tubes to each side of the quick connect tee. Connect one tube to the multiport pressure gauge and the other to the center fitting on the multiport valve (see picture).

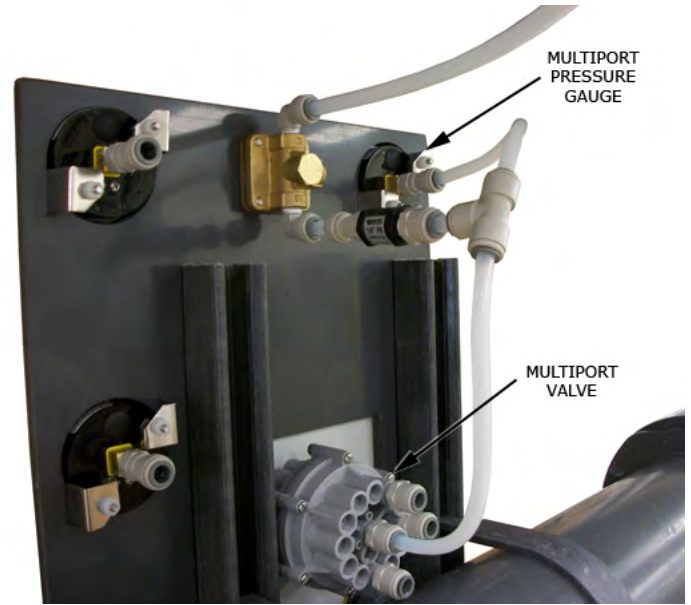

Drill and tap for 1/4" NPT hole on the influent and effluent pipes from the filter system (see schematic diagram in Appendix B). Install quick connect fittings into pipe. **Be sure to use pipe thread sealant tape on the threads.** Install 3/8" OD tube from fittings to rear of the gauge panel assembly. Connect tubes into correct gauge on the rear of the panel (see picture).

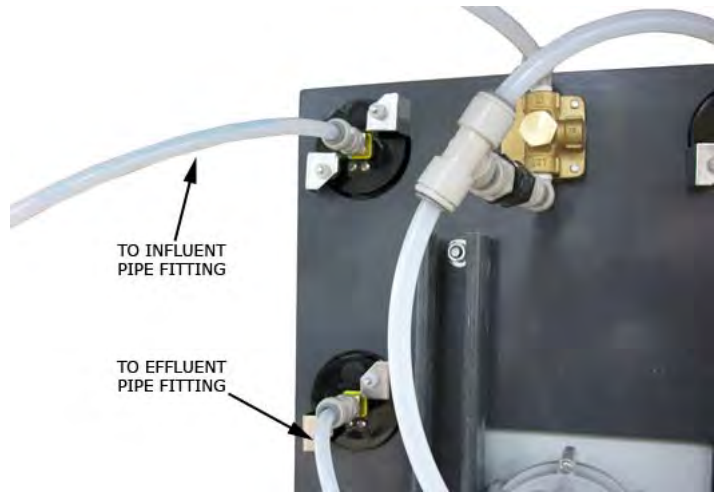

Assemble the And/Or assembly shown in the picture. Be sure to leave enough tubing to reach all of the necessary connections. Connect all tubes to their appropriate locations as explained in the picture.

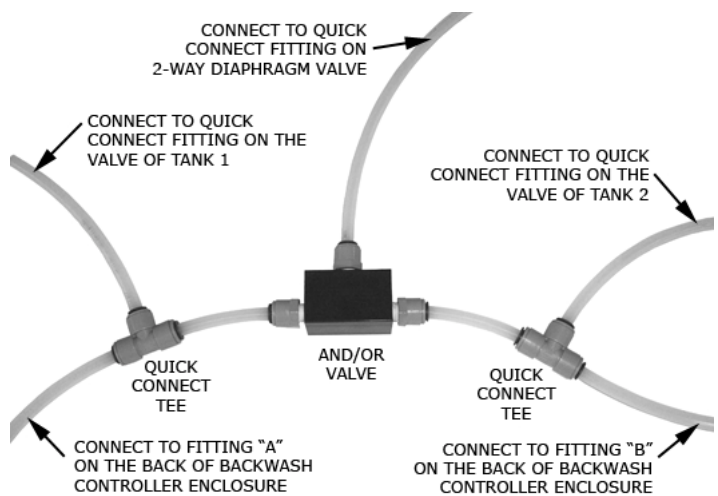

Connect tubes into respective fittings on the back of the backwash controller enclosure. Connect a tube from remaining quick connect fitting and connect to drain.

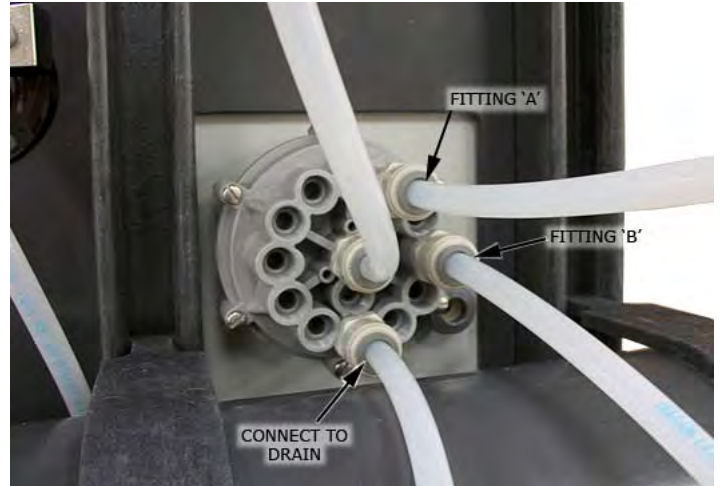

This completes the installation of the backwash controller (CS400) for dual tank systems. Please see Owner's/Operator's Manual for backwash controller set up and operation.

### 3.7 Operation (Semi-Automatic Controller)

The diaphragm valve style face piping kits are designed for simple operation and maintenance. Backwashing is accomplished by turning a single knob to actuate the diaphragm valves. The automatic controller can be set up to backwash automatically dependant on certain chosen parameters, as well manually if required (refer to automatic controller manual for more information). The systems backwash one tank at a time, and in the case of the dual tank systems, each tank is backwashed with clean, filtered water.

The following section will explain briefly how to set the multiport pressure, when to backwash the tanks, how the controllers work, how to initiate a backwash cycle, and how to address maintenance issues.

#### Setting the Multiport Pressure

The multiport pressure is crucial to the operation of both the automatic and semi-automatic controllers. The pressure of the water supplied is what actuates the valves in the system. For the valves to actuate properly there must be 35-40 psi of water pressure supplied to the controller. Both controller kits come with a regulator to adjust the pressure of the supplied water. For the semi-automatic controller kit, the regulator can be located by following the tube from the back of the multiport pressure gauge. For the automatic controller kit, the regulator is located on the top right side of the multiport valve enclosure, next to the multiport pressure gauge. The regulator can be adjusted by turning the top knob (with the slot) with a flathead screw driver. Turning the knob clockwise increases the pressure and counter clockwise decreases pressure. Adjust the regulator until the multiport pressure gauge reads between 35 psi and 40 psi.

#### When to Backwash

Backwashing is the process which is used to clean the filter tanks. There are many ways to determine when to backwash the filters as explained in the Tank Owner's/Operator's Manual, however, the method that is most commonly used with the semi-automatic and automatic controllers offered is the pressure differential method (see Section 4.1 of the tank manual). Both types of controllers offer gauges to monitor influent and effluent pressures to make determining when to backwash easy.

#### Semi-Automatic Controller Operation

##### Controller Overview

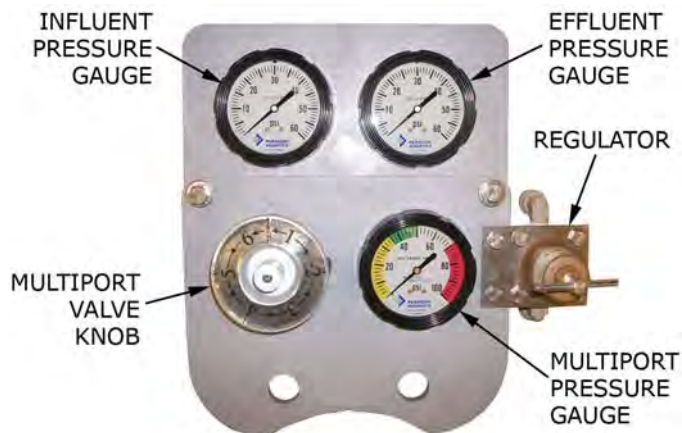

The semi-automatic controller consists of a single gauge panel with gauges to measure influent and effluent pressures, water pressure supplied to the multiport valve, and the multiport valve knob, which is used to actuate the valves.

The influent and effluent pressure gauges show the water pressure coming into and out of the filter system. This information will be useful in determining when the tanks need to be backwashed. The influent pressure should always be higher than the effluent. If it is not, please refer to the troubleshooting section of this manual for assistance.

The multiport pressure gauge shows the water pressure supplied to the multiport valve. **This gauge should read at least 35 psi for proper valve operation.** The water supplied to the multiport valve is what actuates the diaphragm valves. If insufficient water pressure is supplied, the valves may not actuate fully. This can lead to insufficient backwashing of the sand bed, which will diminish the effectiveness of the filters.

The multiport valve knob is what is used to initiate the backwash cycle. On it there will be numbers, which correspond to the tanks, and the word home. When turned to position 1 it will backwash tank one. If there are 2 tanks in the system then position 2 will be used to backwash tank two. The home position is for use in normal filtration mode.

## Switching to Backwash Mode

The following are the steps to follow to initiate a backwash cycle with a semi-automatic controller. This can be used for both single and dual tank systems.

**NOTE: Before actuating the multiport valve, it is recommended that the filter feed pump be turned off. Make sure all isolation valves to the feed pump are in their open position.**

**STEP 1: Rotate the multiport valve to position 1.** This actuates the diaphragm valves. The pressure reading on the multiport pressure gauge will drop as water is allowed to flow into the tops of the valves via the 3/8" polyethylene tubing.



**STEP 2: Verify that multiport pressure gauge returns to normal pressure.**

When actuating the valves the pressure to the multiport valve drops. When the valves become actuated the pressure gauge will begin to rise, and should return to its preset value (35 psi minimum). At this point, the valves are fully actuated. If the pressure does not return to its initial value, please consult the troubleshooting section of this manual. After the pressure has returned to normal, proceed to step 3.

**STEP 3: Backwash the tank for 3-5 minutes.** After the valves actuate, the filter is now running in backwash mode. Water should be coming out of the waste pipe and going to the drain. The filter tank should be backwashed 3-5 minutes, or until the water in the sightglass runs clear. When the water runs clear, the tank is cleaned. **If there is more than one tank in the system proceed to step 4. If the system consists of only one tank, proceed to step 6.**

**STEP 4: Rotate the multiport valve to position 2.** This will actuate the valves to backwash tank 2.



**STEP 5: Follow steps 2 and 3 as explained above.**

**STEP 6: Return the multiport valve to the “Home” position.** This will set system back into normal filtration mode.





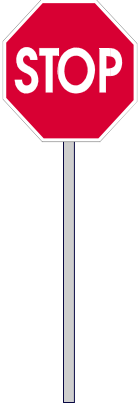

Once system piping and proper valve installation is complete. Including hydraulic lines for valve activation. Hydro test system\*. This must be done **prior to adding media**, start pump, allow system to fill with water to (bleed out all air). Run system for several minutes while doing this inspect for leaks and any unnecessary vibrations that can be reduced by additional support. At this time you will be checking that the pump is providing the flow and pressures in the desired system. Once this is done and installer is satisfied the previous criteria has been met, you may proceed in media installation. Failure to do this may result in damaged parts within the system, which may result in the warranty being voided.

## **4 APPENDIX**

APPENDIX A	TROUBLESHOOTING
APPENDIX B	CONTROLLER INSTALLATION SCHEMATICS
APPENDIX C	FILTER SYSTEM SPECIFICATION SHEETS
APPENDIX D	VALVE ASSEMBLY DRAWINGS

## APPENDIX A

Problem	Possible Cause	Solution
Slow activation of valves	1. Faulty or improperly installed check valve	Verify that valve was installed correctly, making sure the arrow points in the proper direction. Refer to installation instructions for more information. Retry valve actuation.
	2. Faulty or improperly installed regulator	Verify that regulator was installed correctly. Refer to installation instructions for more information. Retry valve actuation.
	3. Not enough pressure to the multiport valve	Verify that the multiport pressure gauge reads between 35 psi and 40 psi. If not, readjust pressure using regulator.
	4. Kinked or obstructed controller tubing	Check to see if and controller tubing is kinked or pinched. If no pinching is present, disconnect the tubing to the valve not actuating and visually inspect for debris which may be blocking the tube.
	5. Failing seals in the multiport valve	Over time the o-ring seals in the multiport valve can become worn and brittle. Eventually these seals will need to be replaced. A good sign of this is water constantly leaking from the multiport valve drain hose. A multiport valve rebuild kit is available from the manufacturer which offers replacement seals.
Inconsistent multiport valve pressure	1. Faulty or improperly installed/adjusted regulator	Verify that regulator was installed correctly. Refer to installation instructions for more information. Adjust regulator, refer to Section 4.1. If regulator adjustment does not fix problem, regulator may need to be replaced.
	2. Failing seals in the multiport valve	Over time the o-ring seals in the multiport valve can become worn and brittle. Eventually these seals will need to be replaced. A good sign of this is water constantly leaking from the multiport valve drain hose. A multiport valve rebuild kit is available from the manufacturer which offers replacement seals.
Leaking through waste pipe in normal filtration mode	1. Debris preventing full closure of sideport seal	Inspect the valve and clear any debris which may be preventing the side port seal from seating correctly. Refer to drawing in Appendix for parts reference.
Valves not actuating/ Can't initiate backwash cycle	1. Not enough pressure to the multiport valve	Verify that the multiport pressure gauge reads between 35 psi and 40 psi. If not, readjust pressure using regulator, refer to Section 4.1.
	2. Faulty or improperly installed and/or valve	Verify that the And/Or valve was installed properly. Refer to installation instructions for more information.

## APPENDIX B

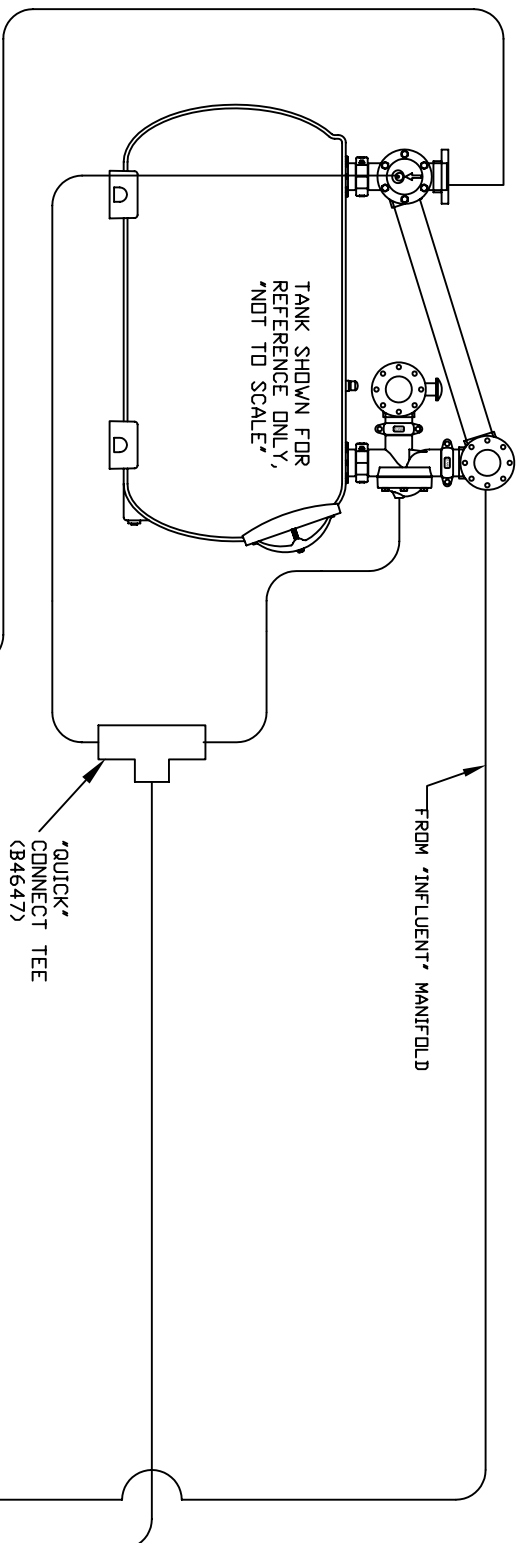

\*-NOTE: QUICK CONNECT FITTINGS, TUBING AND GAGES ARE AVAILABLE THRU YOU STARK DISTRIBUTORS.

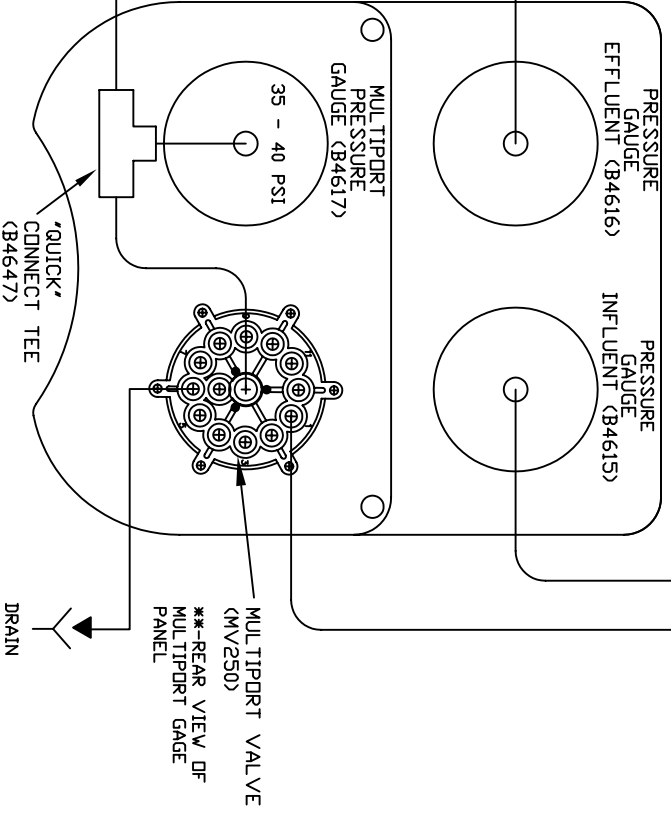
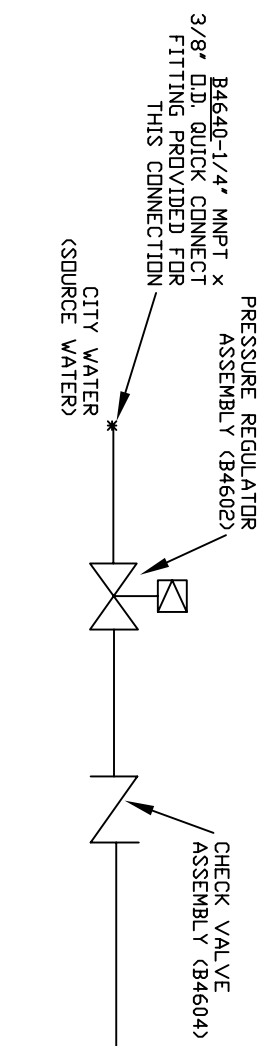

This data represents the latest knowledge available to us at time of presentation. However Paragon Aquatics and others involved in gathering and presenting this drawing assume no liability for its use.

**Pentair**  
Pool Products  
Santford NC/Moorpark CA 800-831-7133

Drawn by: JP	Date: 7/13/01	Title: Installation Instructions for 156400 (Semi-Automatic Controller)	Rev Ltr: B	Sheet: 1 of 1
Approved by:	Date:	Drawing Number: II-156400		



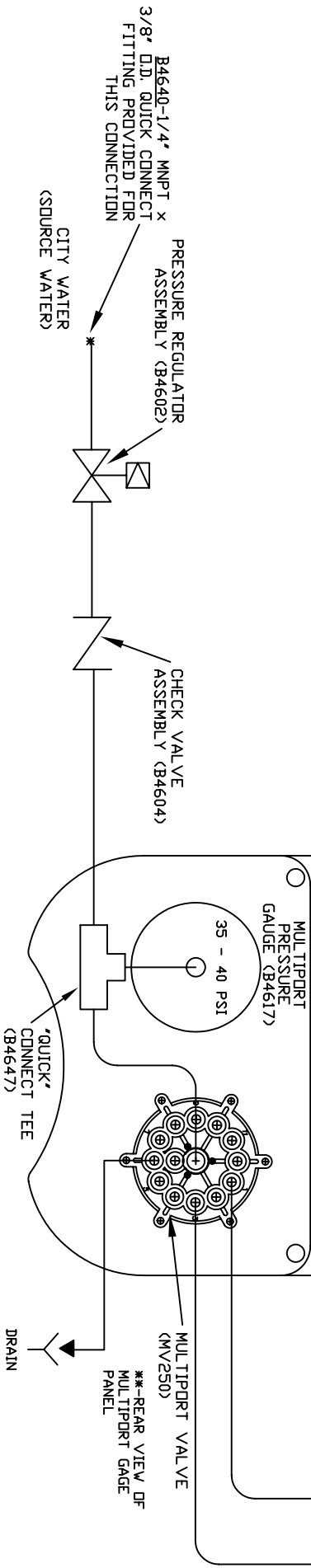
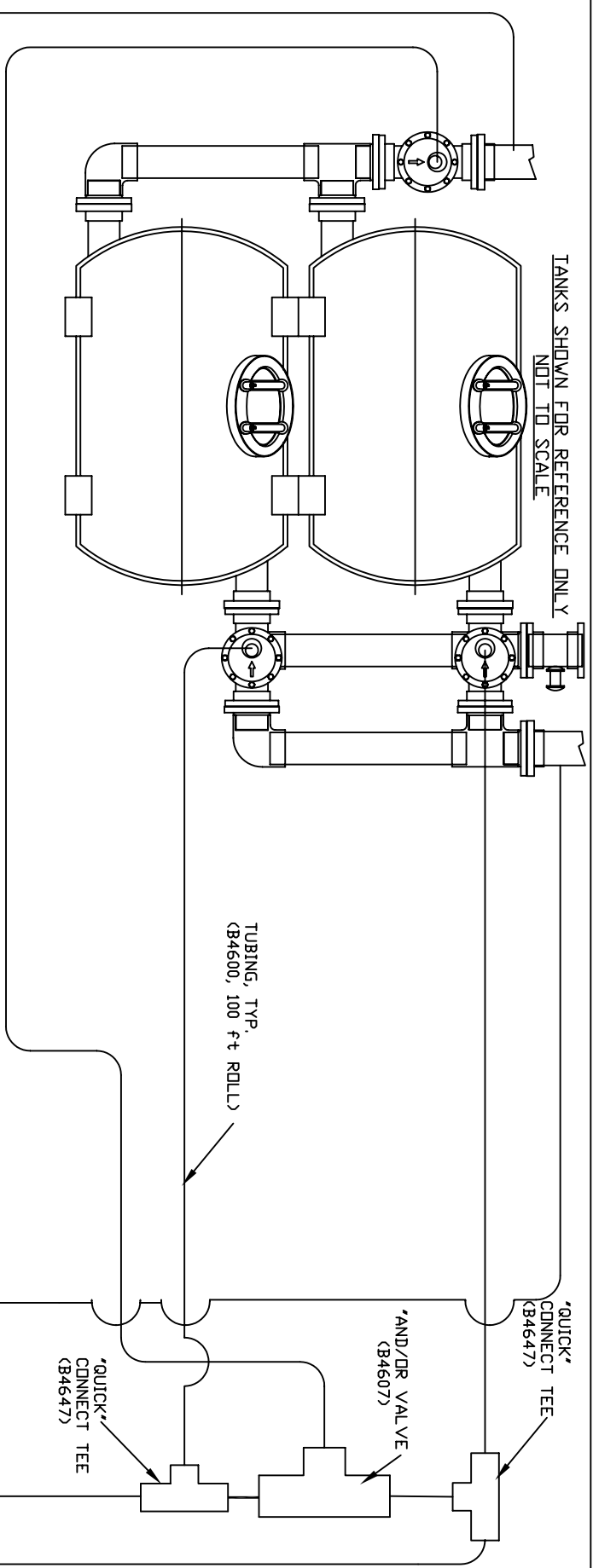

This data represents the latest knowledge available to us at time of presentation. However Paragon Aquatics and others involved in gathering and presenting this drawing assume no liability for its use.

© 2002 Paragon Aquatics

**Pentair**  
Pool Products

Sanford NC/Moorpark CA 800-831-7133

Drawn by: JP	Date: 7/13/01	Title: Installation Instructions for 156450 (Semi-Automatic Controller)
Approved by:	Date:	Drawing Number: II-156450
Rev Ltr: B	Sheet: 1 of 1	

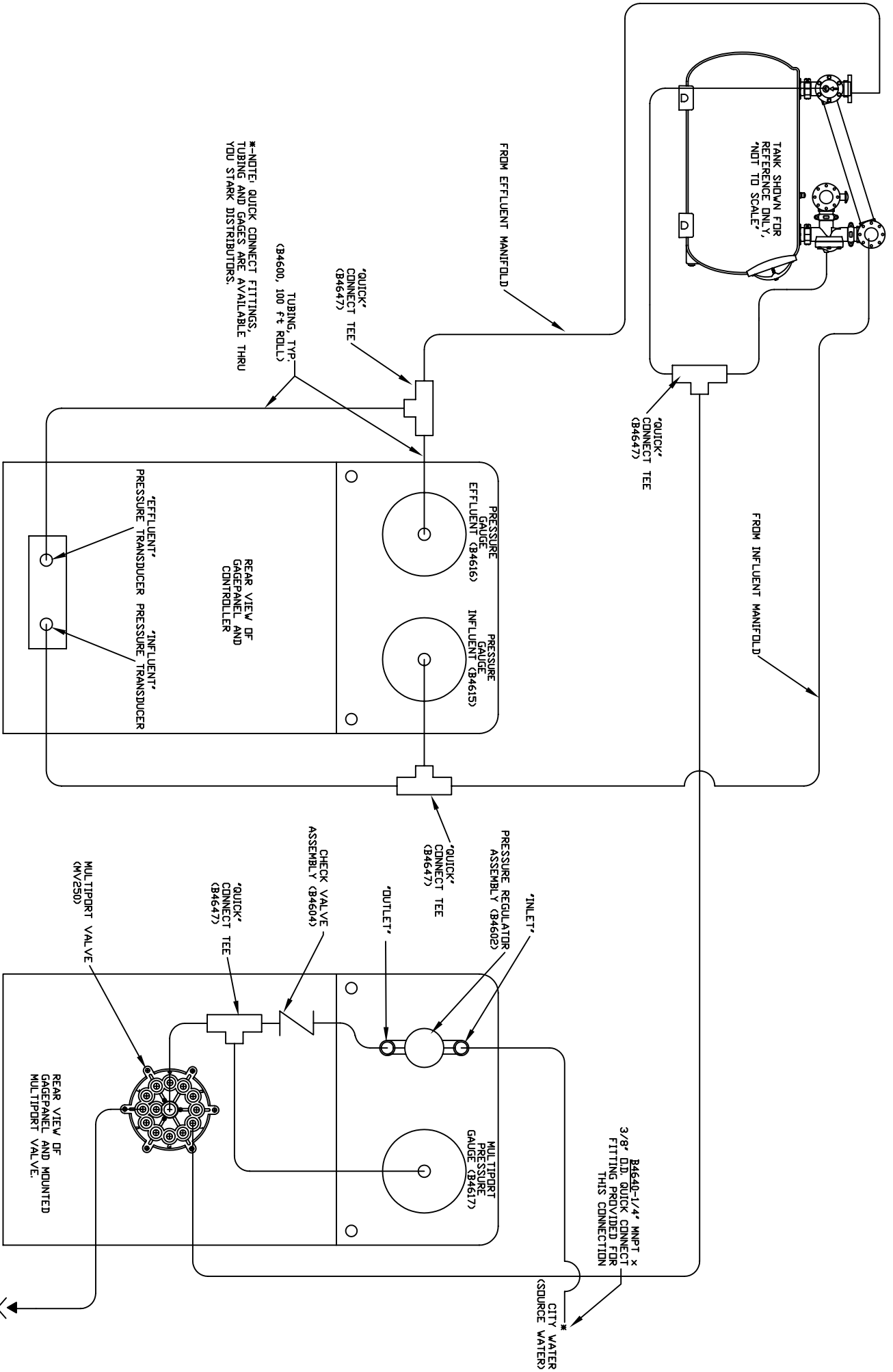

\*-NOTE: QUICK CONNECT FITTINGS, TUBING AND GAGES ARE AVAILABLE THRU YOU STARK DISTRIBUTORS.

TUBING, TYP. (B4600, 100 ft ROLL)

\*\*-NOTE: MOUNTING STRUT NOT SHOWN FOR CLARITY.  
 \*\*-NOTE: REFER TO AUTOMATIC CONTROLLER MANUAL FOR ADDITIONAL INFORMATION.

This data represents the latest knowledge available to us at time of presentation. However Paragon Aquatics and others involved in gathering and presenting this drawing assume no liability for its use.

© 2002 Paragon Aquatics

**Pentair**  
 Pool Products  
 Sanford NC/Moorpark CA 800-831-7133

Drawn by:	Date:	Title:
JP	7/13/01	Installation Instructions for 156850 (Automatic Controller)
Approved by:	Date:	Drawing Number:
		11-156850
Rev Ltr:	Rev Ltr:	Sheet:
B		1 of 1

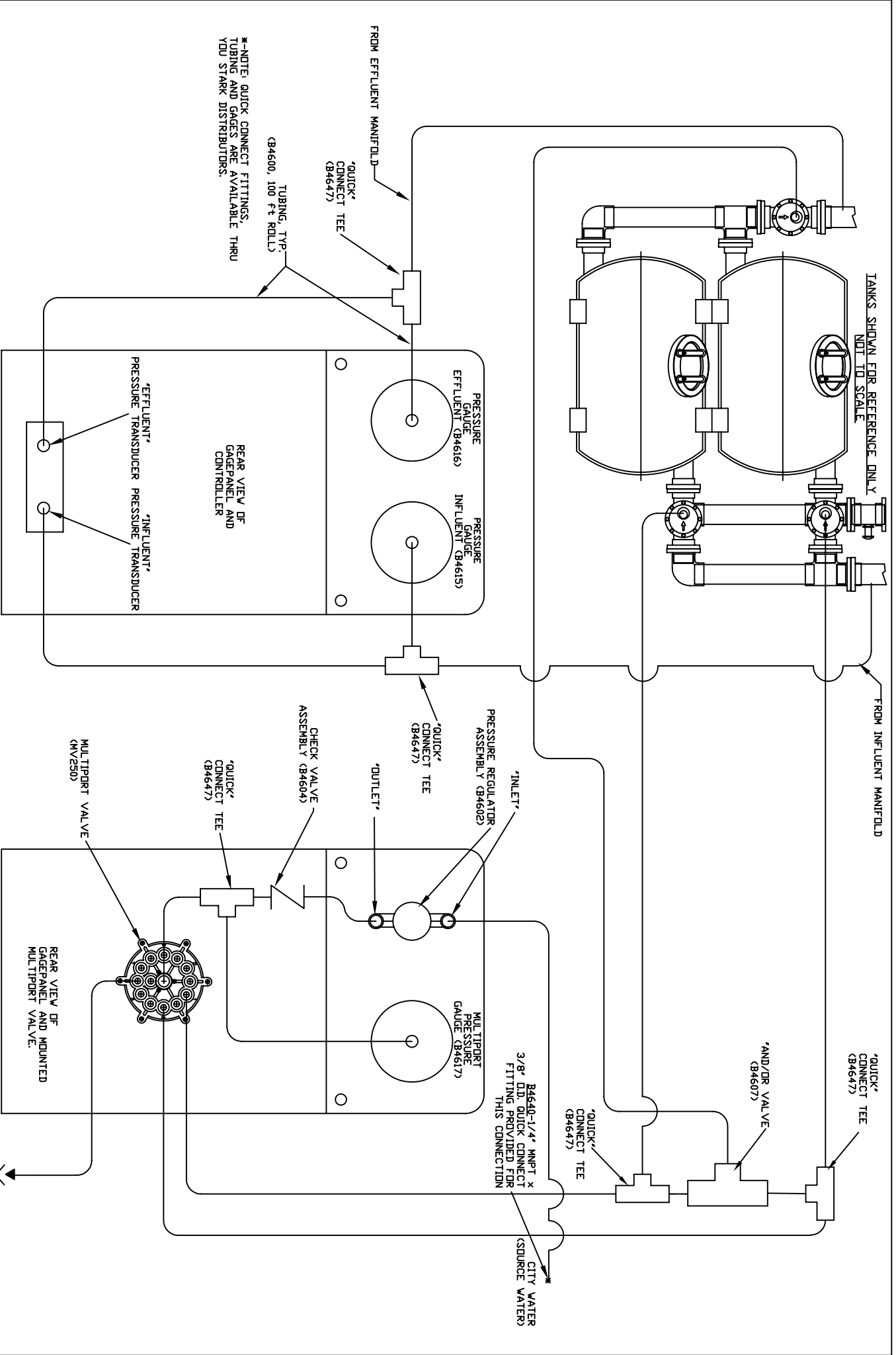

\*-NOTE QUICK CONNECT FITTINGS TUBING AND GAGES ARE AVAILABLE THRU YOU STARK DISTRIBUTORS.

(B4600, 100 ft ROLL) TUBING, TYP.

\*\*\*NOTE: MOUNTING STRUT NOT SHOWN FOR CLARITY.  
 \*\*\*NOTE: REFER TO AUTOMATIC CONTROLLER MANUAL FOR ADDITIONAL INFORMATION.

This data represents the latest knowledge available to us at time of presentation. However Paragon Aquatics and others involved in gathering and presenting this drawing assume no liability for its use.

**Paragon Aquatics**  
 Sanford NC/Moorpark CA 800-831-7133

Drawn by: JP	Date: 7/13/01	Title: Installation Instructions for 156800 (Automatic Controller)	Rev Ltr: B	Sheet: 1 of 1
Approved by:	Date:	Drawing Number: II-156800		

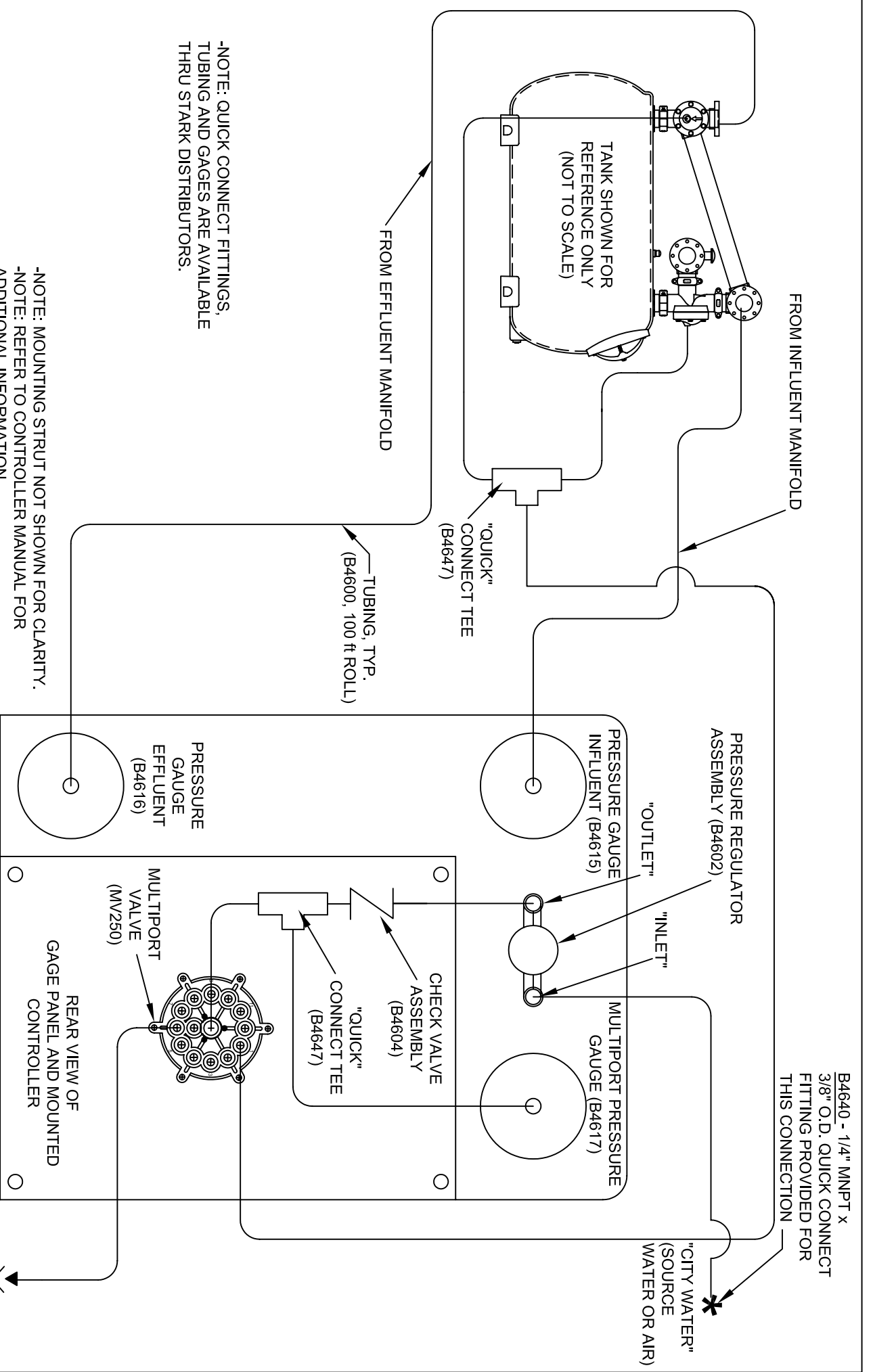

-NOTE: QUICK CONNECT FITTINGS, TUBING AND GAGES ARE AVAILABLE THRU STARK DISTRIBUTORS.

-NOTE: MOUNTING STRUT NOT SHOWN FOR CLARITY.  
 -NOTE: REFER TO CONTROLLER MANUAL FOR ADDITIONAL INFORMATION.

This data represents the latest knowledge available to us at time of presentation. However Paragon Aquatics and others involved in gathering and presenting this drawing assume no liability for its use.  
 © 2010 Paragon Aquatics

**PARAGON AQUATICS**  
 Pentate Water  
 Commercial Pool & Aquatics  
 1351 Route 55  
 LaGrangeville, New York  
 12540  
 Phone: 845-463-7200  
 Fax: 845-463-7291  
 www.paragonaquatics.com

Drawn by:	Date:	Title:	Rev Ltr:	Sheet:
JP	3/16/09	Installation Instructions (Hydraulics) for CS400-01 (Backwash Controller For Single Tank)	A	1 of 1
Approved by:	Date:	Drawing Number:		
JP	3/16/09	II-CS400-01		

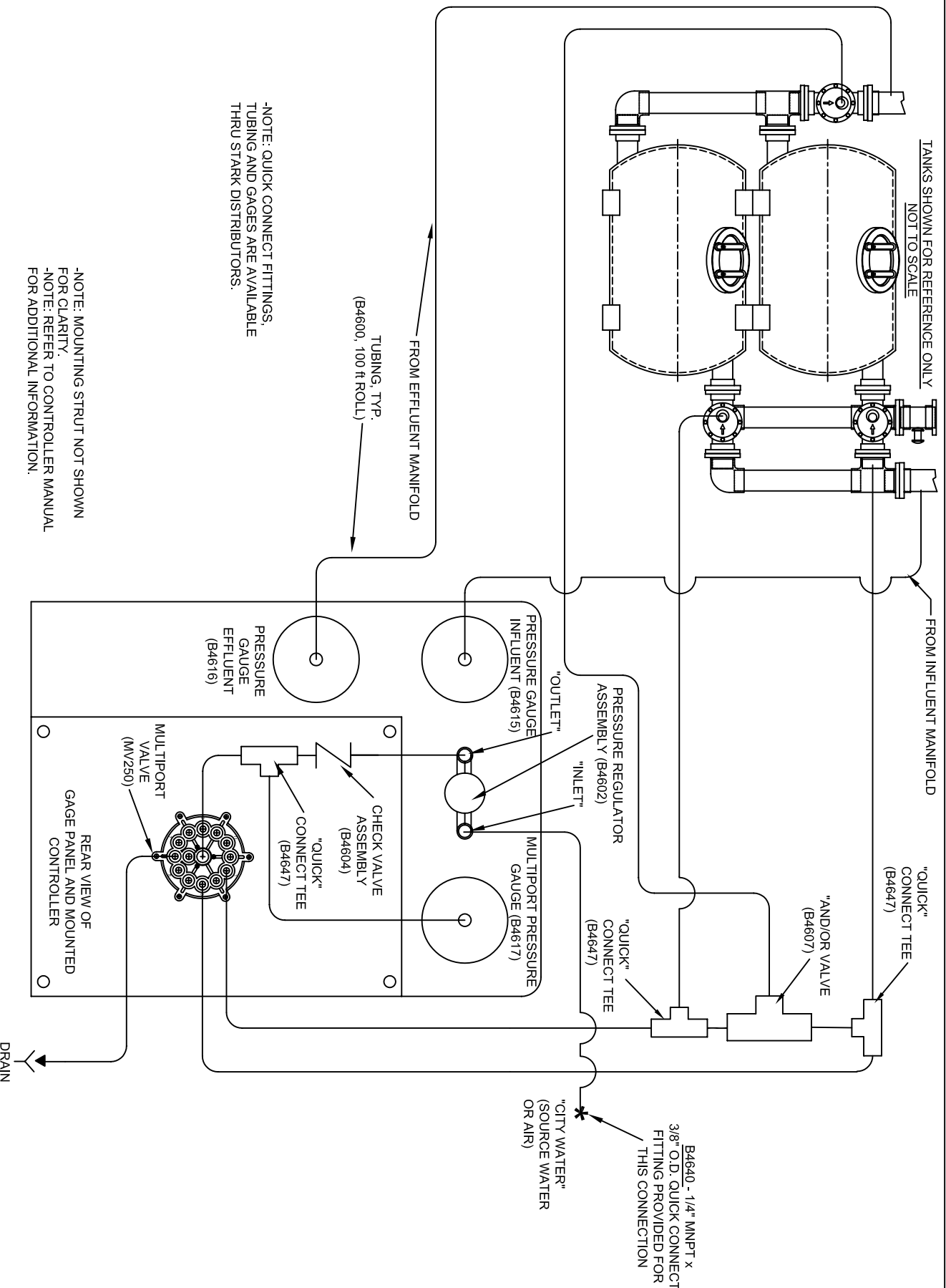

TANKS SHOWN FOR REFERENCE ONLY  
NOT TO SCALE

FROM INFLUENT MANIFOLD

FROM EFFLUENT MANIFOLD

TUBING, TYP.  
(B4600, 100 ft ROLL)

-NOTE: QUICK CONNECT FITTINGS,  
TUBING AND GAGES ARE AVAILABLE  
THRU STARK DISTRIBUTORS.

-NOTE: MOUNTING STRUT NOT SHOWN  
FOR CLARITY.  
-NOTE: REFER TO CONTROLLER MANUAL  
FOR ADDITIONAL INFORMATION.

B4640 - 1/4" MNPT x  
3/8" O.D. QUICK CONNECT  
FITTING PROVIDED FOR  
THIS CONNECTION

"CITY WATER"  
(SOURCE WATER  
OR AIR)

DRAIN

This data represents the latest knowledge available to us at time of presentation. However Paragon Aquatics and others involved in gathering and presenting this drawing assume no liability for its use.  
© 2010 Paragon Aquatics

**PARAGON**  
**AQUATICS**  
Pond & Water  
Commercial Pond & Aquatics

1351 Route 55  
Lagrangeville, New York  
12540  
Phone: 845-463-7200  
Fax: 845-463-7291  
www.paragonaquatics.com

Drawn by:	Date:	Title:
JP	3/16/09	Installation Instructions (Hydraulics) for CS400-02 (Backwash Controller for Two Tanks)
Approved by:	Date:	Drawing Number:
JP	3/16/09	II-CS400-02
Rev Ltr:	Sheet:	
A	1 of 1	



## APPENDIX C

- NOTES:
1. TOTAL FILTRATION AREA: (13.5) SQ. FT.
  2. SYSTEM IS SHOWN WITH OPTIONAL FACE-PIPING KIT (155703). A SEMI AUTOMATIC (156400) OR AUTOMATIC (156850) CONTROL OPTION MUST BE ORDERED IN CONJUNCTION.
  3. DIMENSIONS ARE IN INCHES. DIMENSIONS ARE APPROXIMATE. DO NOT PRESET ANCHORS.
  4. ALL PIPING MUST BE SUPPORTED WITH ADEQUATE BRACING AND HANGERS (BY OTHERS) TO PREVENT DAMAGE FROM WEIGHT AND VIBRATION.

Model	Filter Area (ft <sup>2</sup> )	Max Flow Rates			Media Requirements						Operating Weight (lbs.)	Shipping Weight (lbs.)
		Flow Rate @ 10 GPM/ft <sup>2</sup> (GPM)	Flow Rate @ 15 GPM/ft <sup>2</sup> (GPM)	Flow Rate @ 20 GPM/ft <sup>2</sup> (GPM)	Sand Media (ft <sup>2</sup> )	Gravel Media (ft <sup>2</sup> )	Total Media (ft <sup>2</sup> )	Freeboard Height (in.)	Sand Bed Depth (in.)	Gravel Depth (in.)		
THS3461	13.5	135	202.5	270	12.5 (1250 lbs.)	3.0 (300 lbs.)	15.5 (1550 lbs.)	7 1/2	9	8 5/16	3496	530

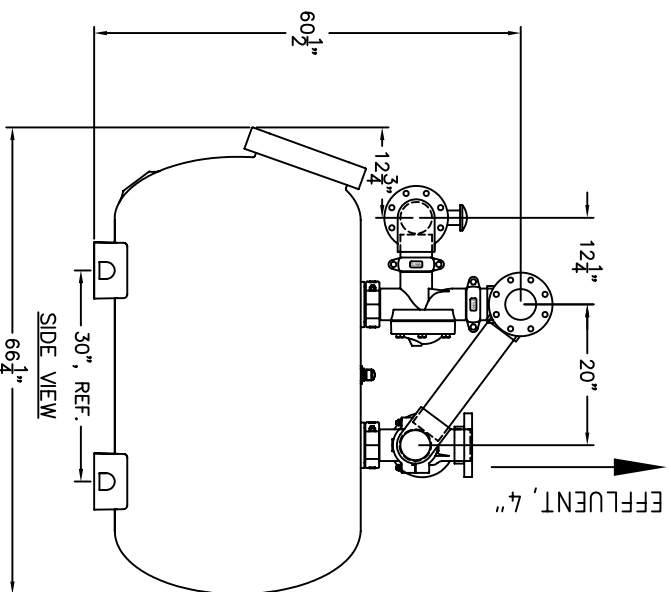
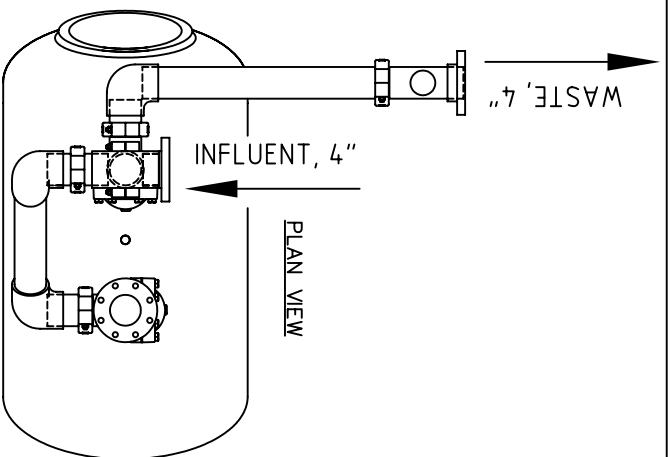
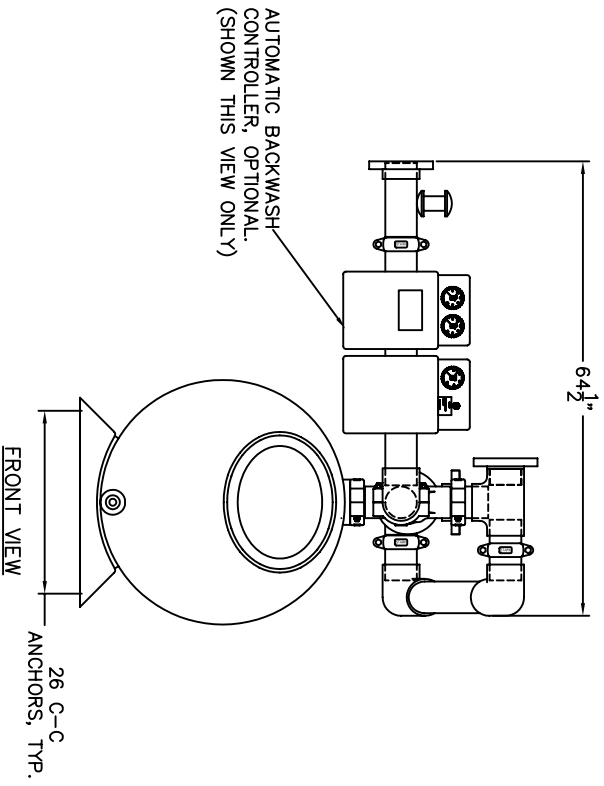

This data represents the latest knowledge available to us at time of presentation. However Paragon Aquatics and others involved in gathering and presenting this drawing assume no liability for its use.

© 2011 Paragon Aquatics



**Pentair Water**

Commercial Pool and Spa™  
Sandford, NC / Moorpark, CA 800-831-7133

Drawn by:	JP	Date:	11/3/05	Title:	SPECIFICATIONS FOR SINGLE (THS3461) SMOOTHIE TANK "DIAPHRAGM VALVE OPTIONAL FACE PIPING KIT" WITH 4"
Approved by:	JP	Date:	2/9/11	Drawing Number:	SS-155703
		Rev Ltr:	A	Sheet:	1 of 1

- NOTES:
1. TOTAL FILTRATION AREA: 19 SQ. FT.
  2. SYSTEM IS SHOWN WITH OPTIONAL FACE-PIPING KIT (155701). A SEMI AUTOMATIC (156400) OR AUTOMATIC (156850) CONTROL OPTION MUST BE ORDERED IN CONJUNCTION.
  3. DIMENSIONS ARE IN INCHES. DIMENSIONS ARE APPROXIMATE. DO NOT PRESET ANCHORS.
  4. ALL PIPING MUST BE SUPPORTED WITH ADEQUATE BRACING AND HANGERS (BY OTHERS) TO PREVENT DAMAGE FROM WEIGHT AND VIBRATION.

Model	Max Flow Rates			Media Requirements						
	Filter Area (ft <sup>2</sup> )	Flow Rate @ 10 GPM/ft <sup>2</sup> (GPM)	Flow Rate @ 15 GPM/ft <sup>2</sup> (GPM)	Flow Rate @ 20 GPM/ft <sup>2</sup> (GPM)	Sand Media (ft <sup>2</sup> )	Gravel Media (ft <sup>2</sup> )	Total Media (ft <sup>2</sup> )	Freeboard Height (in.)	Sand Bed Depth (in.)	Gravel Depth (in.)
THS3484	19.0	190	285	380	13.5 (1350 lbs.)	6.0 (600 lbs.)	19.5 (1950 lbs.)	7 1/2	9	8 5/16

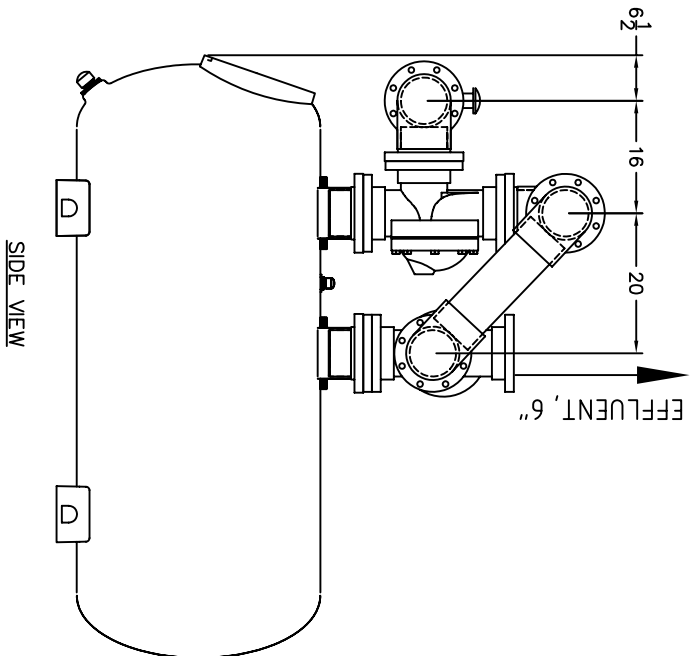
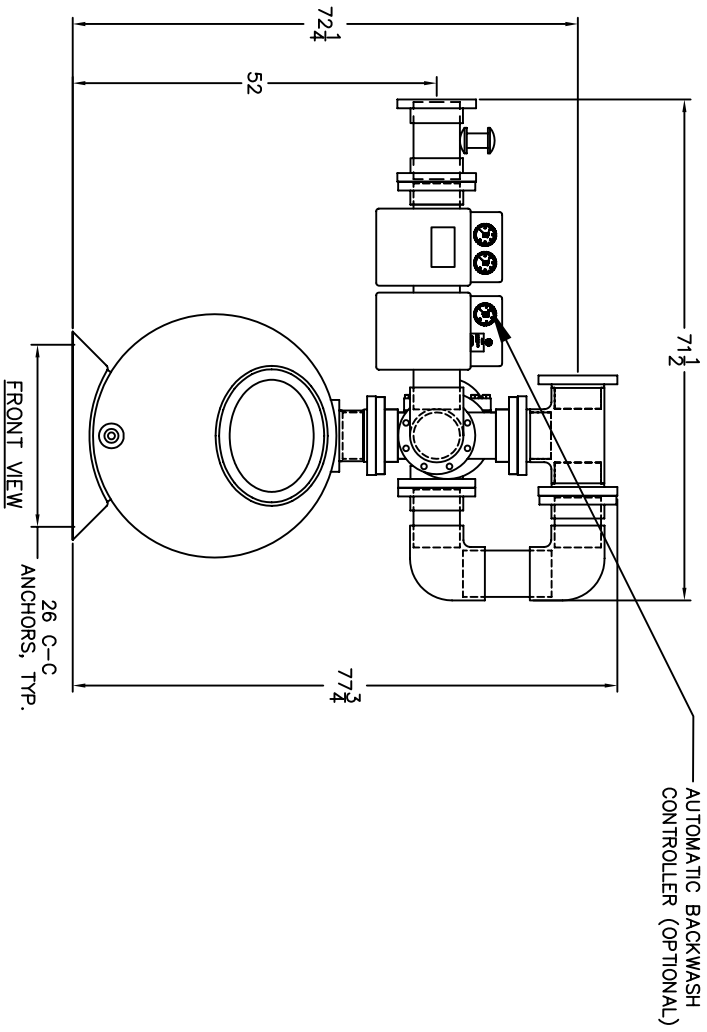
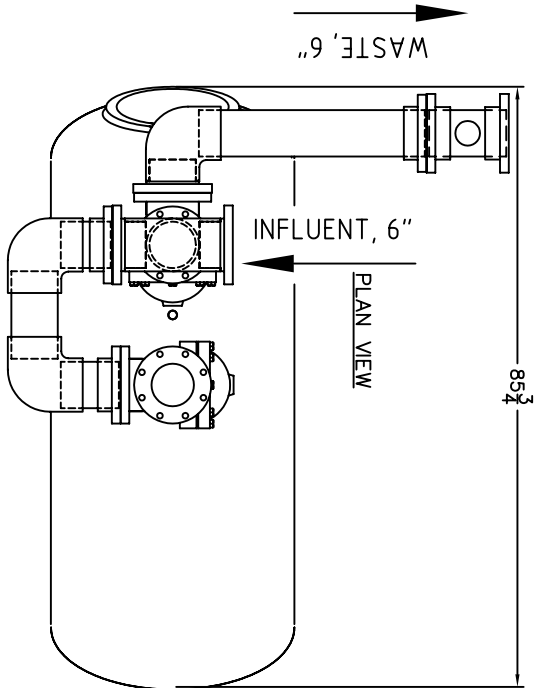

This data represents the latest knowledge available to us at time of presentation. However Paragon Aquatics and others involved in gathering and presenting this drawing assume no liability for its use.

© 2011 Paragon Aquatics

**Pentair Water**  
Commercial Pool and Spa™  
Sanford, NC / Moorpark, CA 800-831-7133

Drawn by: PAM	Date: 2/10/05	Title: SPECIFICATIONS FOR SINGLE (34") SMOOTHIE TANK "OPTIONAL FACE PIPING KIT" WITH 6" CONNECTIONS	Rev Ltr: D
Approved by: JP	Date: 2/15/11	Drawing Number: SS-THS1-2 (34")	Sheet: 1 of 1

- NOTES:
1. TOTAL FILTRATION AREA: (see matrix) SQ. FT.
  2. SYSTEM IS SHOWN WITH OPTIONAL FACE-PIPING KIT (155701). A SEMI AUTOMATIC (156400) OR AUTOMATIC (156850) CONTROL OPTION MUST BE ORDERED IN CONJUNCTION.
  3. DIMENSIONS ARE IN INCHES. DIMENSIONS ARE APPROXIMATE. DO NOT PRESET ANCHORS.
  4. ALL PIPING MUST BE SUPPORTED WITH ADEQUATE BRACING AND HANGERS (BY OTHERS) TO PREVENT DAMAGE FROM WEIGHT AND VIBRATION.

Model	Max Flow Rates			Media Requirements				* - Dimensions			
	Filter Area (ft <sup>2</sup> )	Flow Rate @ 10 GPM/ft <sup>2</sup> (GPM)	Flow Rate @ 15 GPM/ft <sup>2</sup> (GPM)	Flow Rate @ 20 GPM/ft <sup>2</sup> (GPM)	Sand Media (ft <sup>2</sup> )	Gravel Media (ft <sup>2</sup> )	Total Media (ft <sup>2</sup> )	Freeboard Height (in.)	Sand Bed Depth (in.)	Gravel Depth (in.)	"A" in.
THS4272	19.7	197	296	394	21.0 (2100 lbs.)	5.0 (500 lbs.)	26.0 (2600 lbs.)				74
THS4284	23.2	232	348	464	24.0 (2400 lbs.)	6.0 (600 lbs.)	30.0 (3000 lbs.)	9 1/2	15	7 1/2	86
THS4296	26.7	267	401	534	28.0 (2800 lbs.)	7.0 (700 lbs.)	35.0 (3500 lbs.)				98

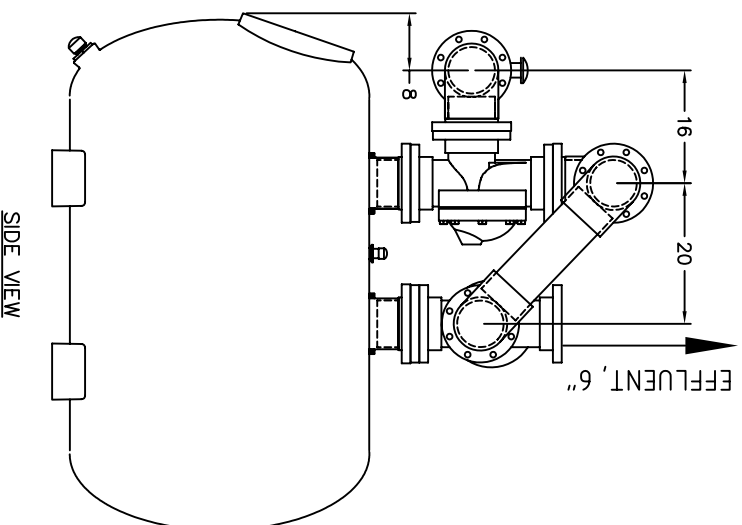
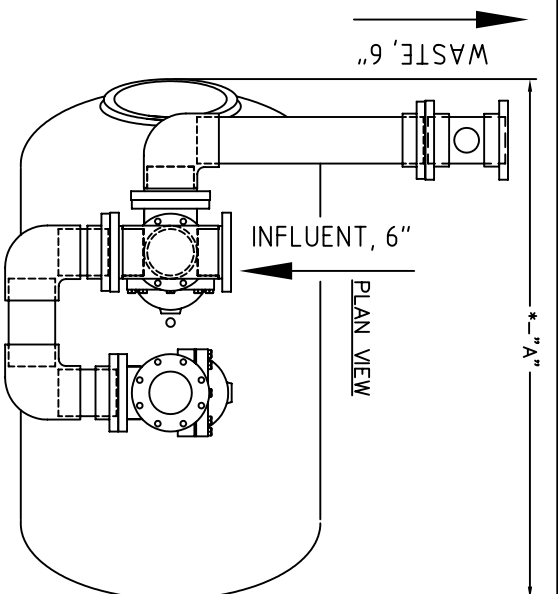
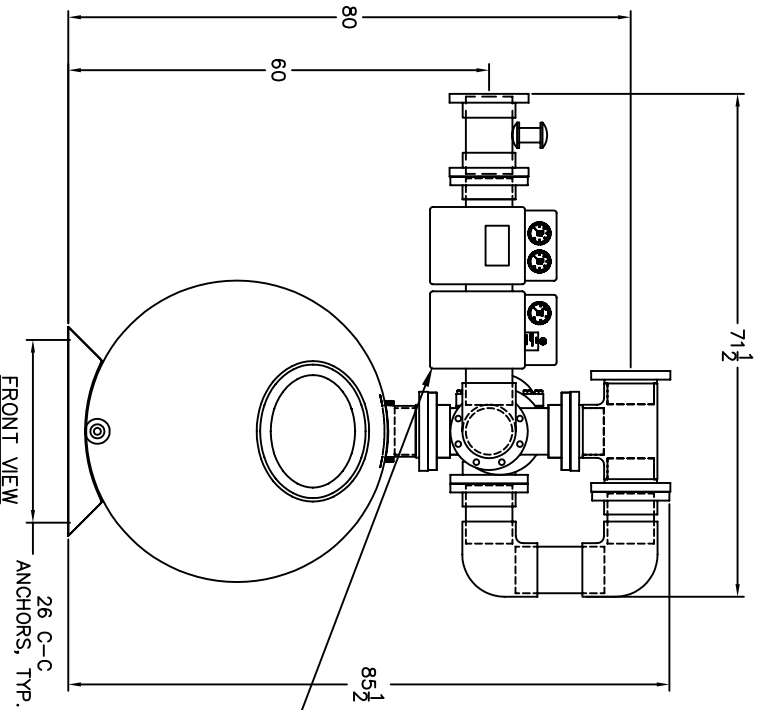

This data represents the latest knowledge available to us at time of presentation. However Paragon Aquatics and others involved in gathering and presenting this drawing assume no liability for its use.

© 2011 Paragon Aquatics



**Pentair Water**  
Commercial Pool and Spa™

Sanford, NC / Moorpark, CA 800-831-7133

Drawn by: PAM  
Date: 2/10/05  
Approved by: JP  
Date: 2/15/11

Title: SPECIFICATIONS FOR SINGLE (42") SMOOTHIE TANK  
"OPTIONAL FACE PIPING KIT" WITH 6" CONNECTIONS  
Drawing Number: SS-THS1-1 (42")  
Rev Ltr: E  
Sheet: 1 of 1

**NOTES:**

1. THIS FACE PIPING-KIT IS DESIGNED FOR A MAXIMUM FLOW RATE OF 800 GPM.
2. SYSTEM IS SHOWN WITH OPTIONAL FACE-PIPING KIT (155723). A SEMI-AUTOMATIC (156450) OR AUTOMATIC (156800) CONTROL OPTION MUST BE ORDERED IN CONJUNCTION.
3. DIMENSIONS ARE IN INCHES. DIMENSIONS ARE APPROXIMATE. DO NOT PRESET ANCHORS.
4. ALL PIPING MUST BE SUPPORTED WITH ADEQUATE BRACING AND HANGERS (BY OTHERS) TO PREVENT DAMAGE FROM WEIGHT AND VIBRATION.

Model	Filter Area (ft <sup>2</sup> )	Max Flow Rates			Media Requirements (for Two Tanks)					
		Flow Rate @ 10 GPM/ft <sup>2</sup> (GPM)	Flow Rate @ 15 GPM/ft <sup>2</sup> (GPM)	Flow Rate @ 20 GPM/ft <sup>2</sup> (GPM)	Sand Media (ft <sup>3</sup> )	Gravel Media (ft <sup>3</sup> )	Total Media (ft <sup>3</sup> )	Freeboard Height (in.)	Sand Bed Depth (in.)	Gravel Depth (in.)
THS3461	27 (13.5 per tank)	270	405	540	25.0 (2500 lbs.)	6.0 (600 lbs.)	31.0 (3100 lbs.)	7 1/2	9	8 5/16

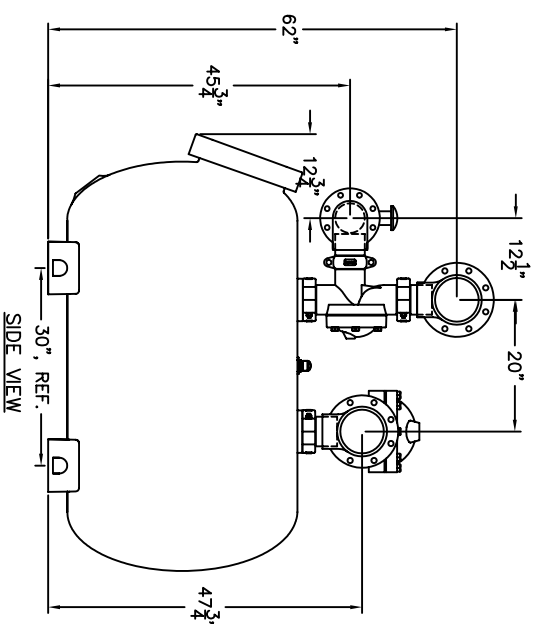
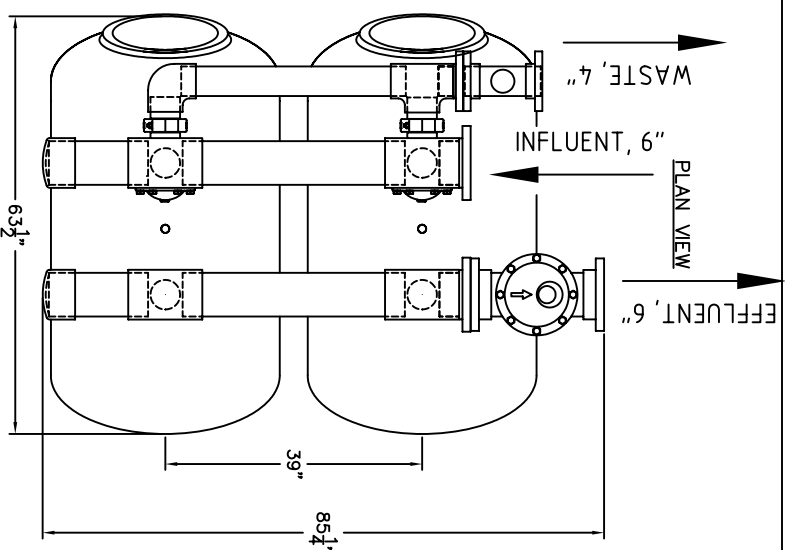
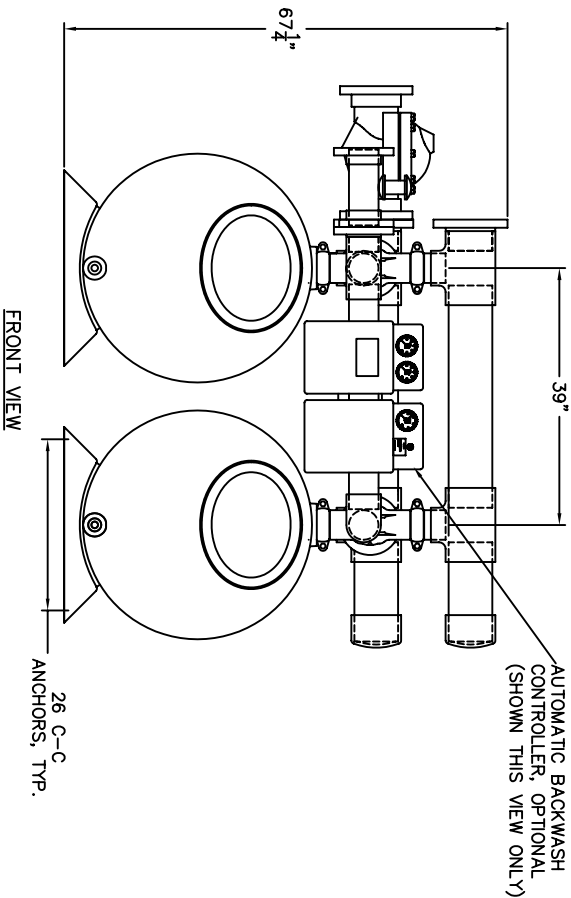

This data represents the latest knowledge available to us at time of presentation. However, Paragon Aquatics and others involved in gathering and presenting this drawing assume no liability for its use.



Drawn by:	JP	Date:	11/1/05	Title:	SPECIFICATIONS FOR A 2 (THS3461) TANK SMOOTHIE FILTER SYSTEM "OPTIONAL FACE PIPING KIT"
Approved by:	JP	Date:	2/9/11	Drawing Number:	SS-155723
				Rev Ltr:	A
				Sheet:	1 of 1



**NOTES:**

1. THIS FACE PIPING-KIT IS DESIGNED FOR A MAXIMUM FLOW RATE OF 800 GPM.
2. SYSTEM IS SHOWN WITH OPTIONAL FACE-PIPING KIT (155721). A SEMI AUTOMATIC (156450) OR AUTOMATIC (156800) CONTROL OPTION MUST BE ORDERED IN CONJUNCTION.
3. DIMENSIONS ARE IN INCHES. DIMENSIONS ARE APPROXIMATE. DO NOT PRESET ANCHORS.
4. ALL PIPING MUST BE SUPPORTED WITH ADEQUATE BRACING AND HANGERS (BY OTHERS) TO PREVENT DAMAGE FROM WEIGHT AND VIBRATION.

Model	Filter Area (ft <sup>2</sup> )	Max Flow Rates			Media Requirements					
		Flow Rate @ 10 GPM/ft <sup>2</sup> (GPM)	Flow Rate @ 15 GPM/ft <sup>2</sup> (GPM)	Flow Rate @ 20 GPM/ft <sup>2</sup> (GPM)	Sand Media (ft <sup>2</sup> )	Gravel Media (ft <sup>2</sup> )	Total Media (ft <sup>2</sup> )	Freeboard Height (in.)	Sand Bed Depth (in.)	Gravel Depth (in.)
THS3484	38 (19 per tank)	380	570	760	27.0 (2700 lbs.)	12.0 (1200 lbs.)	39.0 (3900 lbs.)	7 1/2	9	8 5/16

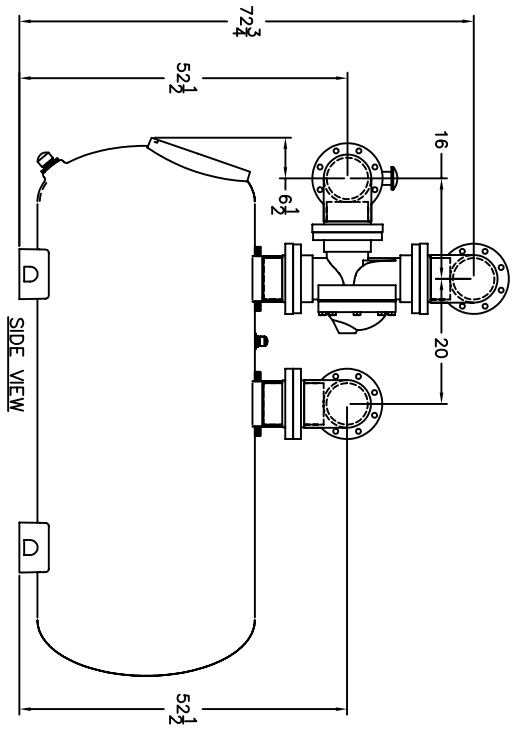
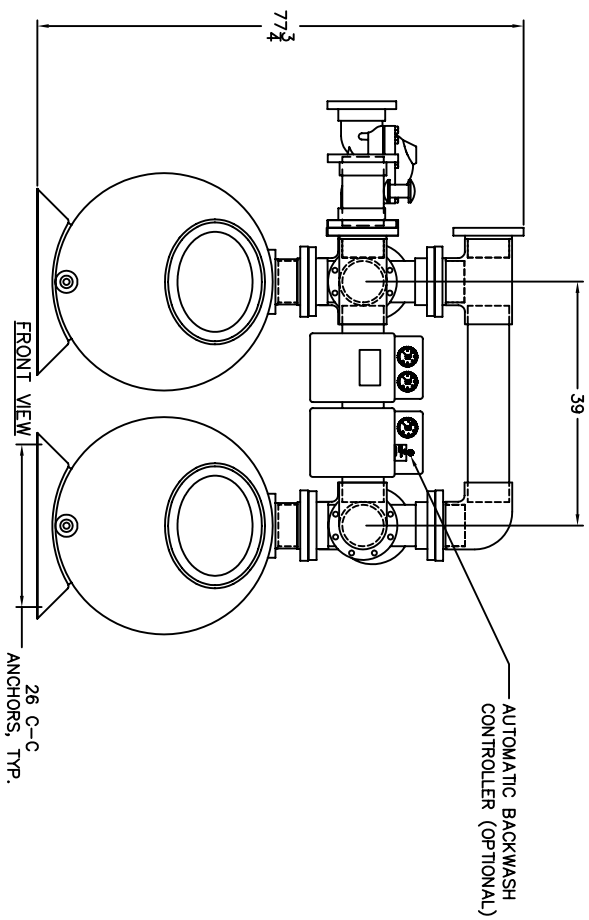
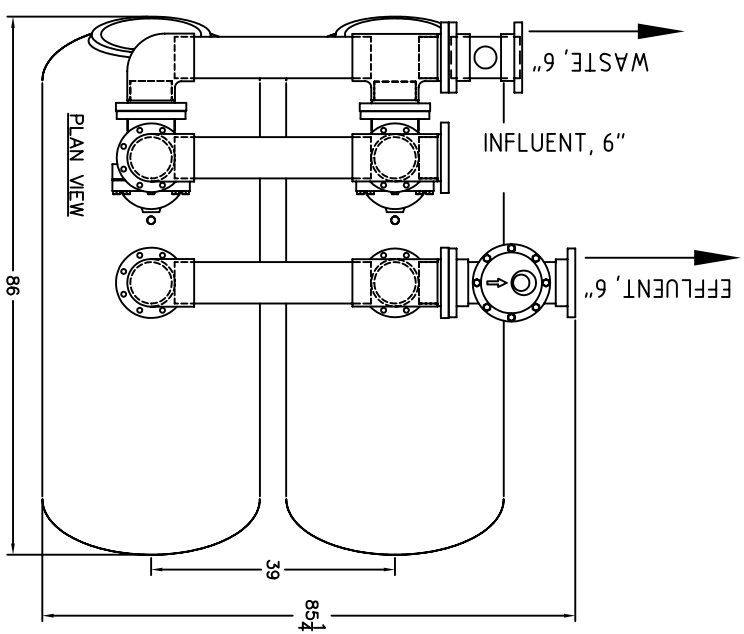

This data represents the latest knowledge available to us at time of presentation. However Paragon Aquatics and others involved in gathering and presenting this drawing assume no liability for its use.

**Pentair Water**  
 Commercial Pool and Spa™  
 Sanford, NC / Moorpark, CA 800-831-7133

Drawn by: PAM	Date: 2/10/05	Title: SPECIFICATIONS FOR A 2 (34") TANK SMOOTHIE FILTER SYSTEM "OPTIONAL FACE PIPING KIT
Approved by: JP	Date: 2/15/11	Drawing Number: SS-THS34-1 (34")
	Rev Ltr: E	Sheet: 1 of 1

- NOTES:
1. THIS FACE PIPING-KIT IS DESIGNED FOR A MAXIMUM FLOW RATE OF 800 GPM.
  2. SYSTEM IS SHOWN WITH OPTIONAL FACE-PIPING KIT (155730). A SEMI AUTOMATIC (156450) OR AUTOMATIC (156800) CONTROL OPTION MUST BE ORDERED IN CONJUNCTION.
  3. DIMENSIONS ARE IN INCHES. DIMENSIONS ARE APPROXIMATE. DO NOT PRESET ANCHORS.
  4. ALL PIPING MUST BE SUPPORTED WITH ADEQUATE BRACING AND HANGERS (BY OTHERS) TO PREVENT DAMAGE FROM WEIGHT AND VIBRATION.

Model	Filter Area (ft <sup>2</sup> )	Max Flow Rates			Media Requirements						"A" in.
		Flow Rate @ 10 GPM/ft <sup>2</sup> (GPM)	Flow Rate @ 15 GPM/ft <sup>2</sup> (GPM)	Flow Rate @ 20 GPM/ft <sup>2</sup> (GPM)	Sand Media (ft <sup>2</sup> )	Grovel Media (ft <sup>2</sup> )	Total Media (ft <sup>2</sup> )	Freeboard Height (in.)	Sand Bed Depth (in.)	Grovel Depth (in.)	
THS4272	39.4 (19.7 per tank)	394	592	788	42.0 (4200 lbs.)	10.0 (1000 lbs.)	50.0 (5000 lbs.)	9 1/2	15	7 1/2	74
THS4284	46.4 (23.2 per tank)	464	696	N/A	48.0 (4800 lbs.)	12.0 (1200 lbs.)	60.0 (6000 lbs.)	9 1/2	15	7 1/2	86
THS4296	53.4 (26.7 per tank)	534	802	N/A	56.0 (5600 lbs.)	14.0 (1400 lbs.)	70.0 (7000 lbs.)				98

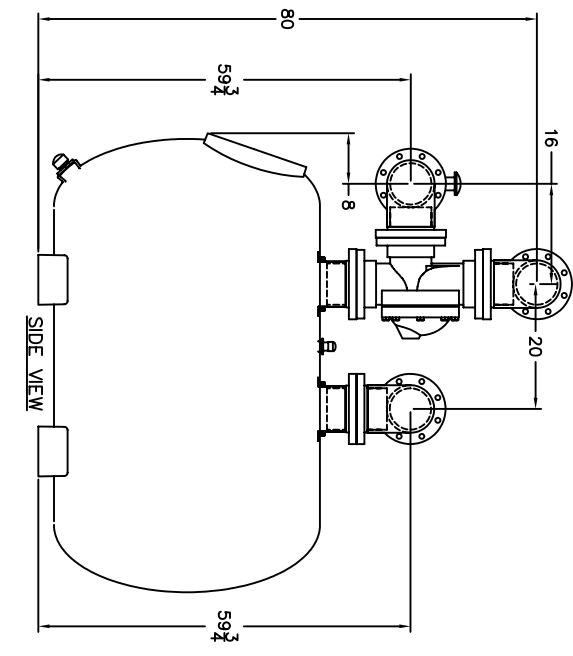
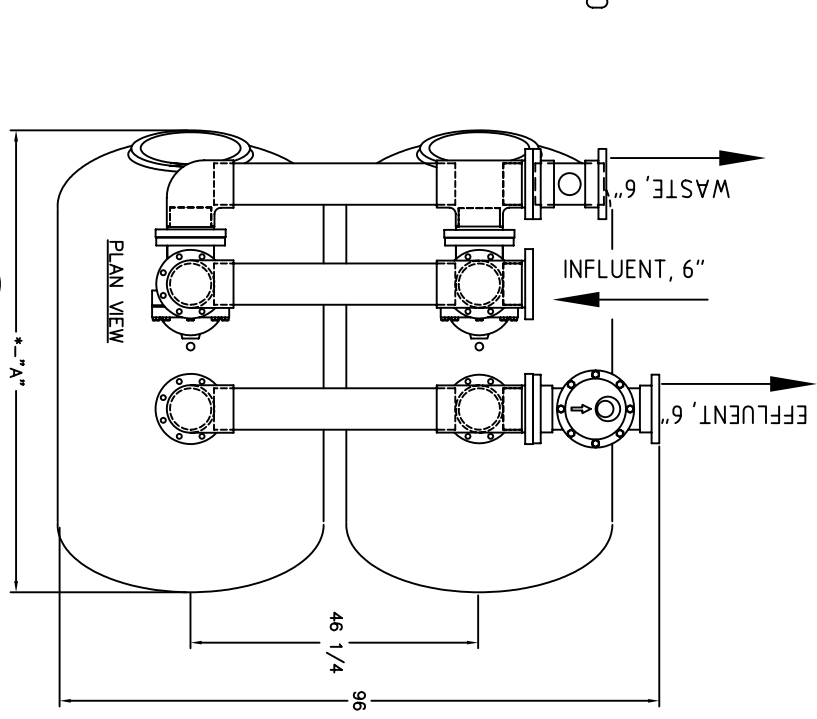
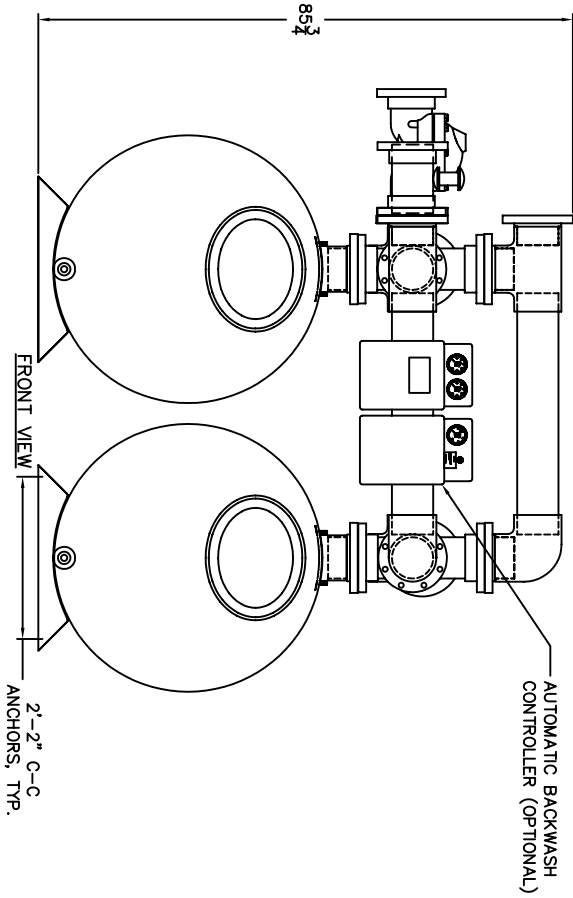

This data represents the latest knowledge available to us at time of presentation. However Paragon Aquatics and others involved in gathering and presenting this drawing assume no liability for its use.



Drawn by: PAM	Date: 2/10/05	Title: SPECIFICATIONS FOR A 2 (42") TANK SMOOTHIE FILTER SYSTEM "OPTIONAL FACE PIPING KIT"
Approved by: JP	Date: 2/15/11	Drawing Number: SS-THS42-1 (42")
Rev Ltr: F	Sheet: 1 of 1	

## APPENDIX D

# STARK 6" 2-WAY VALVE ASSEMBLY

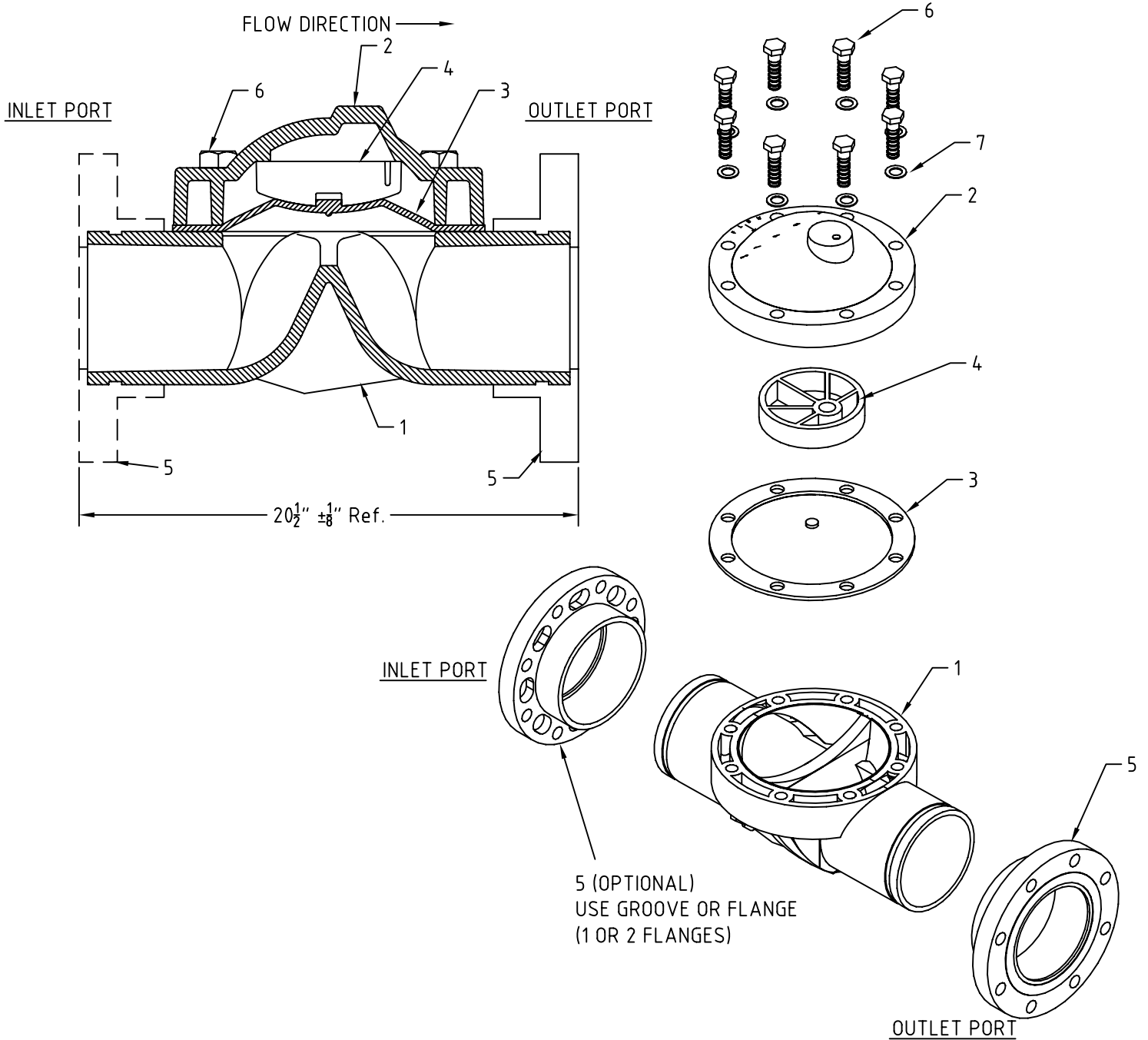

REF.	QTY.	PART #	NAME OR DESCRIPTION
1	1	B4875	6" HOUSING, 2-WAY, DIAPHRAGM VALVE
2	1	B4762	6" COVER, TAPPED, DIAPHRAGM VALVE
3	1	B4763	DIAPHRAGM, 6" VALVE, 2 WAY (W/O HOLE)
4	1	B4878	6" PLATE, DIAPHRAGM VALVE
5	*	B4815	6" FLANGE, SOLID, DIAPHRAGM VALVE
6	8	94901	BOLT, 3/4-10x2-3/4" HEX HD., T316 S/S
7	8	94953	WASHER, .765" I.D. x 1.25" O.D., T316 S/S
8	1	B4642	1/4" MPT x QUICK EL (NOT SHOWN)

This data represents the latest knowledge available to us at time of presentation. However Paragon Aquatics and others involved in gathering and presenting this drawing assume no liability for its use.

© 2009 Paragon Aquatics



**PARAGON**  
**AQUATICS**  
Pentair Commercial Pool & Aquatics  
Div. Pentair Water Pool & Spa, Inc.

1351 Route 55  
LaGrangeville, New York  
12540  
Phone: 845-463-7200  
Fax: 845-463-7291  
www.paragonaquatics.com

Drawn by:	Date:	Title:	<b>STARK</b> 6" DIAPHRAGM VALVE ASSEMBLY DRAWING
SAW	8/3/01		
Approved by:	Date:	Drawing Number:	Rev Ltr: Sheet:
SAW	8/3/01	AI-V2-06	D 1 of 1

# STARK 4" 3-WAY VALVE ASSEMBLY

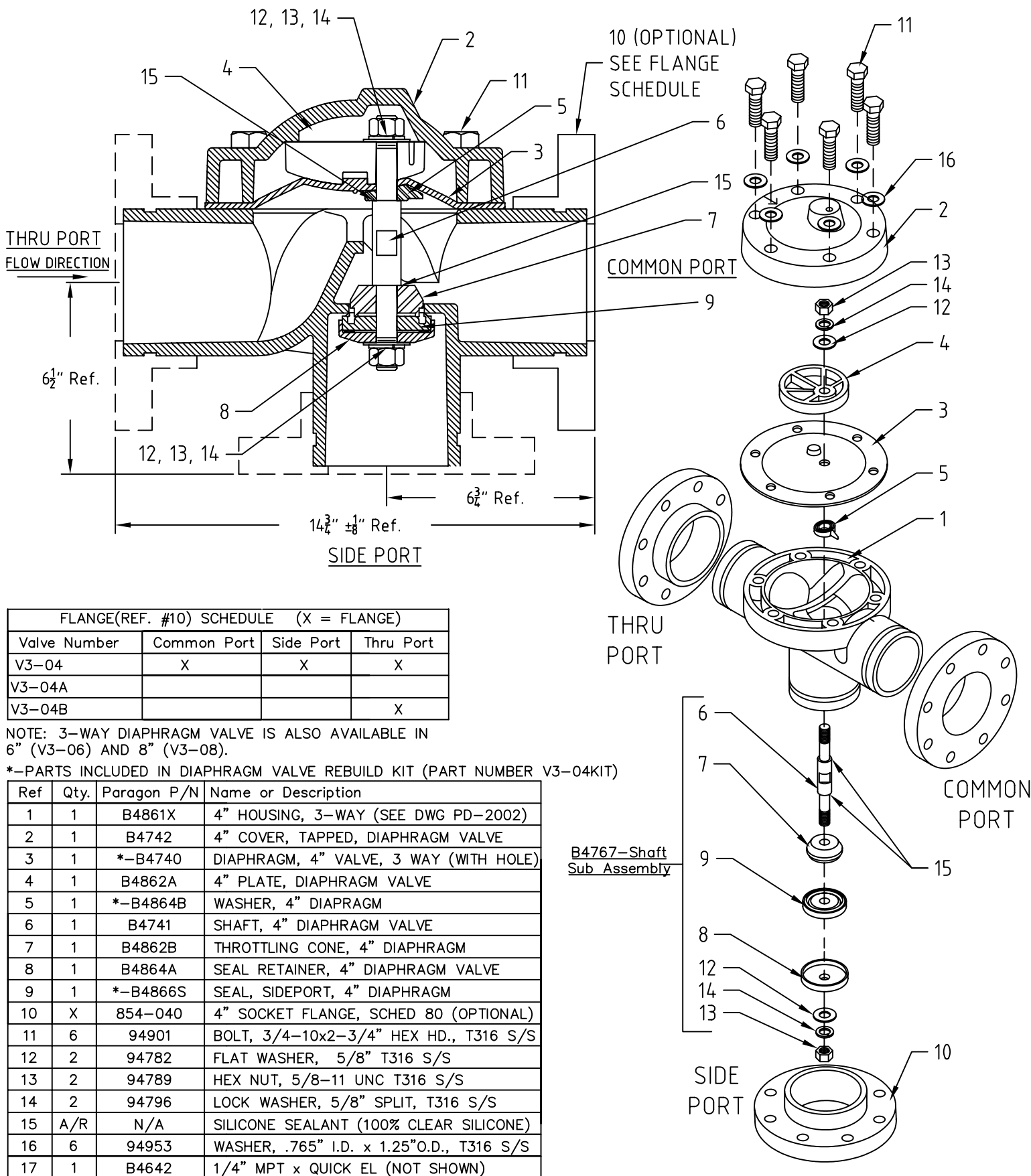

FLANGE(REF. #10) SCHEDULE (X = FLANGE)			
Valve Number	Common Port	Side Port	Thru Port
V3-04	X	X	X
V3-04A			
V3-04B			X

NOTE: 3-WAY DIAPHRAGM VALVE IS ALSO AVAILABLE IN 6" (V3-06) AND 8" (V3-08).

\*-PARTS INCLUDED IN DIAPHRAGM VALVE REBUILD KIT (PART NUMBER V3-04KIT)

Ref	Qty.	Paragon P/N	Name or Description
1	1	B4861X	4" HOUSING, 3-WAY (SEE DWG PD-2002)
2	1	B4742	4" COVER, TAPPED, DIAPHRAGM VALVE
3	1	*-B4740	DIAPHRAGM, 4" VALVE, 3 WAY (WITH HOLE)
4	1	B4862A	4" PLATE, DIAPHRAGM VALVE
5	1	*-B4864B	WASHER, 4" DIAPHRAGM
6	1	B4741	SHAFT, 4" DIAPHRAGM VALVE
7	1	B4862B	THROTTLING CONE, 4" DIAPHRAGM
8	1	B4864A	SEAL RETAINER, 4" DIAPHRAGM VALVE
9	1	*-B4866S	SEAL, SIDEPORT, 4" DIAPHRAGM
10	X	854-040	4" SOCKET FLANGE, SCHED 80 (OPTIONAL)
11	6	94901	BOLT, 3/4-10x2-3/4" HEX HD., T316 S/S
12	2	94782	FLAT WASHER, 5/8" T316 S/S
13	2	94789	HEX NUT, 5/8-11 UNC T316 S/S
14	2	94796	LOCK WASHER, 5/8" SPLIT, T316 S/S
15	A/R	N/A	SILICONE SEALANT (100% CLEAR SILICONE)
16	6	94953	WASHER, .765" I.D. x 1.25" O.D., T316 S/S
17	1	B4642	1/4" MPT x QUICK EL (NOT SHOWN)

B4767-Shaft Sub Assembly

This data represents the latest knowledge available to us at time of presentation. However Paragon Aquatics and others involved in gathering and presenting this drawing assume no liability for its use.

© 2009 Paragon Aquatics



**PARAGON AQUATICS**  
Pentair Commercial Pool & Aquatics  
Div. Pentair Water Pool & Spa, Inc.

1351 Route 55  
LaGrangeville, New York  
12540  
Phone: 845-463-7200  
Fax: 845-463-7291  
www.paragonaquatics.com

Drawn by:

JP

Date:

4/22/02

Title:

**STARK**  
4" 3-WAY VALVE ASSEMBLY DRAWING

Approved by:

JP

Date:

4/22/02

Drawing Number:

AI-V3-04

Rev Ltr:

G

Sheet:

1 of 1



# STARK 6" 3-WAY (CLEAR) VALVE ASSEMBLY

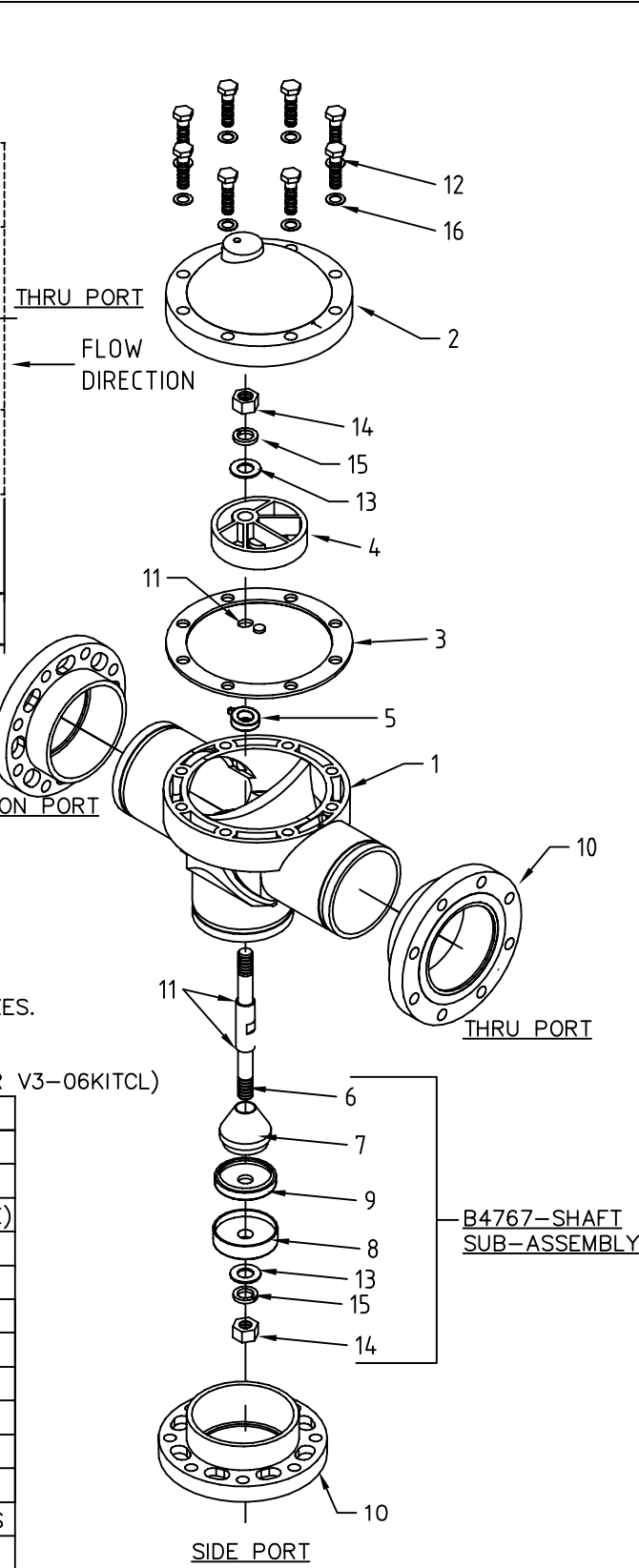
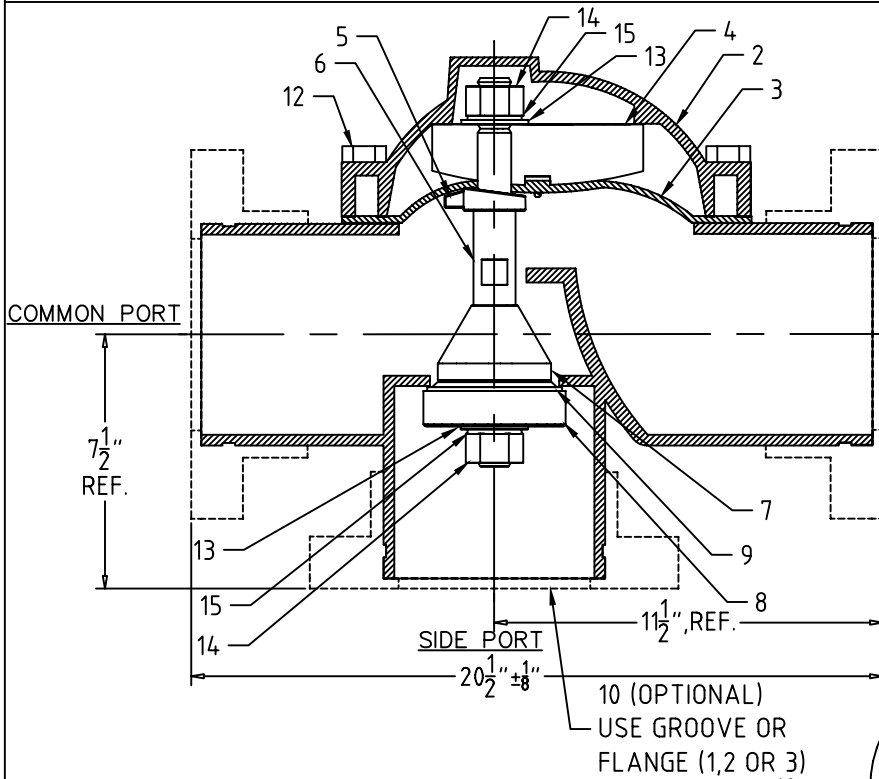

FLANGE(REF. #10) SCHEDULE (X = FLANGE)			
Valve Number	Common Port	Side Port	Thru Port
V3-06CL	X	X	X
V3-06ACL			
V3-06BCL			X

NOTE: 3-WAY DIAPHRAGM VALVE IS ALSO AVAILABLE IN 4" (V3-04) AND 8" (V3-08), CLEAR IS NOT AVAILABLE IN THESE SIZES.

\*-PARTS INCLUDED IN DIAPHRAGM VALVE REBUILD KIT (PART NUMBER V3-06KITCL)

Ref	Qty.	Paragon P/N	Name or Description
1	1	-----	SEE DRAWING NUMBER PD-2002
2	1	B4762CL	6" COVER, TAPPED, DIAPHRAGM VALVE
3	1	*-B4760A	DIAPHRAGM, 6" VALVE, 3 WAY (WITH HOLE)
4	1	B4878	6" PLATE, DIAPHRAGM VALVE
5	1	*-B4879X	WASHER, 6" DIAPHRAGM (GRAY)
6	1	B4761	SHAFT, 6" DIAPHRAGM VALVE
7	1	B4880	THROTTLING CONE, 6" DIAPHRAGM
8	1	B4879B	SEAL RETAINER, 6" DIAPHRAGM VALVE
9	1	*-B4881	SEAL, SIDEPORT, 6" DIAPHRAGM
10	X	B4815	6" FLANGE, SOLID, DIAPHRAGM VALVE
11	A/R	N/A	SILICONE SEALANT (100% CLEAR SILICONE)
12	8	94774	BOLT, 1/2-13x2-3/4" HEX HD., T316 S/S
13	2	94902	WASHER, 2"x1.06"x.120" T316 S/S
14	2	94903	HEX NUT, 1"-8 T316 S/S
15	2	94904	LOCK WASHER, 1" SPLIT, T316 S/S
16	8	94776	WASHER, .515" I.D. x 875"O.D., T316 S/S
17	1	B4642	1/4" MPT x QUICK EL (NOT SHOWN)

B4767-SHAFT SUB-ASSEMBLY

NOTE: FOR GREY 6" 3-WAY VALVES MANUFACTURED PRIOR TO SEPTEMBER OF 2002, PLEASE REFER TO DRAWING NUMBER AI-V3-06.

This data represents the latest knowledge available to us at time of presentation. However Paragon Aquatics and others involved in gathering and presenting this drawing assume no liability for its use.  
© 2009 Paragon Aquatics



Drawn by:	Date:	Title:	<b>STARK</b>	
JMM	2/12/09	6" 3-WAY CLEAR VALVE ASSEMBLY DRAWING		
Approved by:	Date:	Drawing Number:	Rev Ltr:	Sheet:
JMM	2/12/09	AI-V3-06CL	C	1 of 1



**WATER SOLUTIONS**

1620 HAWKINS AVE., SANFORD, NC 27330 • (919) 566-8000  
10951 WEST LOS ANGELES AVE., MOORPARK, CA 93021 • (805) 553-5000  
WWW.PENTAIRCOMMERCIAL.COM

All Pentair trademarks and logos are owned by Pentair, Inc. Pentair Aquatic Systems™ and THS Series® are trademarks and/or registered trademarks of Pentair Water Pool and Spa, Inc. and/or its affiliated companies in the United States and/ or other countries. Unless expressly noted, names and brands of third parties that may be used in this document are not used to indicate an affiliation or endorsement between the owners of these names and brands and Pentair Water Pool and Spa, Inc. Those names and brands may be the trademarks or registered trademarks of those third parties. Because we are continuously improving our products and services, Pentair reserves the right to change specifications without prior notice. Pentair is an equal opportunity employer.

© 2012 Pentair Aquatic Systems. All rights reserved. This document is subject to change without notice.

P/N 155699 REV. F 7/6/12