



# ETi™ 400 HIGH EFFICIENCY HEATER INSTALLATION AND USER'S GUIDE

**⚠ WARNING**

## FOR YOUR SAFETY - READ BEFORE OPERATING

If you do not follow these instructions exactly, a fire or explosion may result, causing property damage, personal injury or loss of life. For additional free copies of this manual; call USA (800) 831-7133

**FOR YOUR SAFETY** - This product must be installed and serviced by authorized personnel, qualified in pool/spa heater installation. Improper installation and/or operation can create carbon monoxide gas, fire or explosion, and flue gases which can cause serious injury, property damage, or death. For indoor installations, as an additional measure of safety, Pentair Water Pool and Spa, Inc. strongly recommends installation of suitable **Carbon Monoxide detectors** in the vicinity of this appliance and in any adjacent occupied spaces. Improper installation and/or operation will void the warranty.

**⚠ WARNING**

Improper installation, adjustment, alteration, service or maintenance can cause property damage, personal injury or death. Installation and service must be performed by a qualified installer, service agency or the gas supplier.

### 120 / 240 VAC NATURAL GAS / LP GAS

Model	Natural
ETi™ 400 NA - ASME	461113

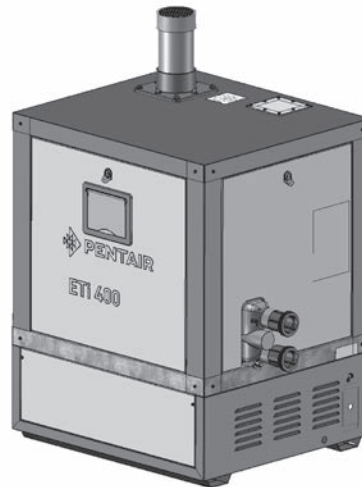

**OWNER:  
Retain For  
Future  
Reference**

## FOR YOUR SAFETY

### WHAT TO DO IF YOU SMELL GAS

- Do not try to light any appliance.
- Do not touch any electrical switch; do not use any phone in your building.
- Immediately call your gas supplier from a neighbor's phone. Follow the gas supplier's instructions.
- If you cannot reach your gas supplier, call the fire department.

DO NOT store or use gasoline or other flammable vapors and liquids in the vicinity of this or other appliances.

## **Customer Service and Technical Support**

If you have questions about ordering Pentair Water Pool and Spa, Inc. replacement parts, and pool products, please call:

**Phone: (800) 831-7133**

**Fax: (800) 284-4151**

(8 AM to 7:30 PM Eastern Time/Pacific Time)

Web sites: [www.pentairpool.com](http://www.pentairpool.com) - [www.staritepool.com](http://www.staritepool.com)

Contents

<b>Warning and Safety Information .....</b>	<b>5</b>
Important Notices .....	5
Heater Application Information .....	5
Code Requirements.....	6
Consumer Information and Safety Information.....	6-8
General Specifications.....	9
<b>Heater Identification Information .....</b>	<b>9</b>
<b>Section 1. Operation Instructions.....</b>	<b>10</b>
Operator Control Panel.....	10-11
Basic System Operation.....	11
Heater DSI Electronic Ignition Lighting/Operation.....	11
Start-Up Operation .....	12
Putting the Heater into Service .....	12
Heater Operating Instructions .....	13
To Turn Off Gas to the Appliance.....	13
Safety Controls (Air Flow Switches, Water Pressure Switches, High Limit Shut-Off Switches) .....	14-15
(Stack Flue Sensor, Thermal Fuse, Float Switch)	
Ignition Module Operation .....	15
<b>Section 2. Installation .....</b>	<b>16</b>
Heater Description.....	16
Putting the Heater into Service.....	16
Sequence Of Operation.....	17
Specifications .....	17-18
Plumbing Connections.....	19
Water Connections .....	19
Valves .....	20
Manual By-Pass .....	20
Below Pool Installation .....	20
Gas Connections .....	21
Gas Pipe Sizing .....	21
Gas Pressure Testing .....	22
Sediment Traps .....	22
Outdoor Installation (US and Canada) .....	23-24
Outdoor Installation Venting Guidelines .....	23
Heater Clearances - Outdoor .....	25
Indoor Venting — General Requirements (Category IV Vertical and Horizontal requirements).....	26
Heater Clearances — General Requirements (Indoor and Outdoor Installation for US and Canada) .....	26
Direct Air Intake Cover.....	26
Combustion Air Supply .....	27
Air Supply Requirements Guide for the Heater .....	27
Direct Air Intake Exhaust Duct using 4-inch PVC Pipe (Indoor Installation) .....	28-30
Direct Air Intake Kit Installation (Combustion Air Supply) .....	30
Corrosive Vapors and Possible Causes .....	30
Horizontal or Vertical Venting (Category IV) - Positive Pressure.....	30
Vent Installation (Indoor Installation for U.S. or Outdoor Shelter for Canada).....	31
Direct Vent Requirements.....	32
Direct Vent - Horizontal Through- the-Wall (Termination).....	34

## Contents

<b>Section 2. Installation (Continued)</b> .....	<b>35</b>
Garage or Utility Room Installation.....	35
Vent Installation - Indoor Installtion US and Canada).....	35
Final Installation Check .....	35
Condensate Management (Maintenance, Condensate Neutralizer Cartridge Drain/Tubing Installation).....	36
Electrical Connections .....	37
Bonding .....	37
120 VAC / 240 VAC Wiring .....	38
Remote Control Connections .....	39
Fireman's Switch Connection .....	39
Heater Connection Wiring Diagram.....	40
Heater Ladder Wiring Diagram.....	41
<b>Section 3. Troubleshooting</b> .....	<b>42</b>
Initial Troubleshooting and Troubleshooting Chart .....	42
Heater Will Not Fire A .....	43
Heater Will Not Fire B.....	44
Diagnostics LEDs: PS, HLS, TF, IGN, AFS, AG1, AG2, FS .....	45-49
Burner Troubleshooting .....	50
Heat Exchanger Troubleshooting .....	50
Operator Control Panel Displays RNC Code.....	50
<b>Section 4. Maintenance and Care Instruction</b> .....	<b>51</b>
Care and Maintenance.....	51
TitanTough Heat Exchanger Assemblies Annual Inspection .....	51
Burner Spark Electrode and Flame Sensor Rod Annual Inspection .....	52
Pressure Relief Valve (50 psi).....	52
After Start-Up .....	53
Spring and Autumn.....	53
Winter Operation and Winterization .....	53
Return the Heater to Service.....	54
Maintaining Pool Temperature .....	54
Energy Saving Tips .....	54
Chemical Balance .....	55-56
<b>Section 5. Heater Replacement Parts</b> .....	<b>57-63</b>
Heater Replacement Parts List.....	57
General Replacement Parts.....	58
Heater Heat Exchanger and Blower Assemblies Replacement Parts.....	59-60
Heater Manifold Assembly - Inlet and Outlet Assembly Replacement Parts.....	61
Heater Condensate and Exhaust Assembly Replacement Parts .....	62
Heater Operator Control Panel Assembly Replacement Parts .....	63

# Warning and Safety Instructions

## IMPORTANT SAFETY INSTRUCTIONS READ AND FOLLOW ALL INSTRUCTIONS SAVE THESE INSTRUCTIONS

### ETi™ 400 High Efficiency Pool and Spa Heater

Thanks you for choosing the Pentair ETi™ 400 High Efficiency Pool and Spa Heater. With proper installation and service of your new heating system, and correct chemical maintenance of the water will ensure years of heater operation. The ETi 400 High Efficiency heater is equipped with Pentair advanced heater technology which includes a multifunction temperature controller to continuously monitor the heater for proper operation. ETi 400 High Efficiency heaters are designed with direct spark ignition (DSI) for on demand heat, which eliminates the need for a standing pilot.

**SPECIAL INSTRUCTIONS TO OWNER:** Retain this manual for future reference. This instruction manual provides operating instructions, installation and service information for the heater. **READ AND REVIEW THIS MANUAL COMPLETELY**, it is very important that the owner/installer read and understand the section covering installation instructions, and recognize the local and state codes before installing the ETi™ 400 High Efficiency heater. Its use will reduce service calls and chance of injury and will lengthen product life. History and experience has shown that most heater damage is caused by improper installation practices.

### IMPORTANT NOTICES

**For the installer and operator of the ETi 400 High Efficiency Heater:** The manufacturer's warranty may be void if, for any reason, the heater is improperly installed and/or operated. Be sure to follow the instructions set forth in this manual. If you need any more information, or if you have any questions regarding to this pool heater, please contact Pentair Water Pool and Spa Customer Support at (800) 831-7133.

### HEATER APPLICATION INFORMATION

The ETi 400 Heater is sold with a limited factory warranty. Pentair Water Pool and Spa high standards of excellence include a policy of continuous product improvement resulting in your advanced technology pool and spa heater. Pentair reserves the right to make improvements which change the specifications of the heater without incurring an obligation to update the current heater equipment.

The ETi 400 Heater is designed for the heating of chlorine, bromine or salt system swimming pools and spas. The heater should never be employed for use as space heating boilers or general purpose water heaters. The manufacturer's warranty may be void if, for any reason, the heater is improperly installed and/or operated. Be sure to follow the instructions set forth in this manual.

### CODE REQUIREMENTS

Installation must be in accordance with all local codes and/or the latest edition of the National Fuel Gas Code, ANSI Z223.1 and the latest edition of the National Electrical Code, NFPA 70 (US).

Installation in Canada must be in accordance with the latest CAN/CGA-B149.1 or .2 and CSA C22.1 Canadian Electric Code, part 1.

The heater, when installed, must be electrically grounded and bonded in accordance with local codes, or, in absence of local codes, with the National Electrical Code, ANSI/NFPA70 (US) or in Canada in accordance with the Canadian Electric Code, part 1 as applicable.

The ETi 400 Pool Heater meets the requirements of the ASME Boiler and Pressure Vessel Code.



## CONSUMER INFORMATION AND SAFETY

### WARNING

**The U.S. Consumer Product Safety Commission warns that elevated water temperature can be hazardous. See below for water temperature guidelines before setting temperature.**

1. Spa or hot tub water temperatures should never exceed 104° F (40° C). A temperature of 100° F (38° C) is considered safe for a healthy adult. Special caution is suggested for young children.
2. Drinking of alcoholic beverages before or during spa or hot tub use can cause drowsiness which could lead to unconsciousness and subsequently result in drowning.
3. Pregnant women beware! Soaking in water above 102° F (39° C) can cause fetal damage during the first three months of pregnancy (resulting in the birth of a brain-damaged or deformed child). Pregnant women should stick to the 100° F (38° C) maximum rule.
4. Before entering the spa or hot tub, the user should check the water temperature with an accurate thermometer. Spa or hot tub thermostats may error in regulating water temperatures by as much as 4° F (2.2° C).
5. Persons with a medical history of heart disease, circulatory problems, diabetes or blood pressure problems should obtain their physician's advice before using spas or hot tubs.
6. Persons taking medication which induce drowsiness, such as tranquilizers, antihistamines or anticoagulants should not use spas or hot tubs.

### WARNING

**Should overheating occur or the gas supply fail to shut off, turn off the manual gas control valve to the heater. Do not use this heater if any part has been under water. Immediately call a qualified service technician to inspect the heater and to replace any part of control system and gas control which has been under water.**

### WARNING

**The U.S. Consumer Product Safety Commission warns that carbon monoxide is an "invisible killer". Carbon monoxide is a colorless and odorless gas.**

1. Carbon monoxide is produced by burning fuel, including natural gas and propane.
2. Proper installation, operation and maintenance of fuel-burning appliances in the home is the most important factor in reducing carbon monoxide poisoning.
3. Be sure that fuel burning appliances such as heaters are installed by professionals according to manufacturer's instructions and codes.
4. Always follow the manufacturer's directions for safe operation.
5. Have the heating system (including vents) inspected and serviced annually by a trained service technician.
6. Examine vents regularly for improper connections, visible cracks, rust or stains.
7. Install battery-operated carbon monoxide alarms. The alarms should be certified to the requirements of the most recent UL, IAS, CSA and IAPMO standard for carbon monoxide alarms. Test carbon monoxide alarms regularly and replace dead batteries.

## SAFETY INFORMATION

The ETi™ 400 High Efficiency Pool and Spa Heater is designed and manufactured to provide many years of safe and reliable service when installed, operated and maintained according to the information in this manual. Throughout this manual, safety warnings and cautions are identified by the “” symbol. Be sure to read and comply with all of the warnings and cautions.

### **DANGER — CARBON MONOXIDE GAS IS DEADLY READ OWNERS MANUAL COMPLETELY BEFORE OPERATING**

THIS PRODUCT MUST BE INSTALLED AND SERVICED BY A PROFESSIONAL SERVICE TECHNICIAN, QUALIFIED IN POOL HEATER INSTALLATION. Some jurisdictions require that installers be licensed. Check with your local building authority about contractor licensing requirements. Improper installation and/or operation could create carbon monoxide gas and flue gases which could cause serious injury or death. Improper installation and/or operation will void the warranty.

Exhaust from this pool heater contains toxic levels of carbon monoxide, a dangerous, poisonous gas you cannot see or smell. Symptoms of carbon monoxide exposure or poisoning include dizziness, headache, nausea, weakness, sleepiness, muscular twitching, vomiting and inability to think clearly. IF YOU EXPERIENCE ANY OF THE ABOVE SYMPTOMS, IMMEDIATELY TURN OFF THE POOL HEATER, LEAVE THE VICINITY OF THE POOL OR SPA AND GET INTO FRESH AIR IMMEDIATELY. THE POOL HEATER MUST BE THOROUGHLY TESTED BY A GAS PROFESSIONAL BEFORE RESUMING OPERATION.

**EXCESSIVE CARBON MONOXIDE EXPOSURE CAN CAUSE BRAIN DAMAGE OR DEATH.**

- NEVER use this pool heater indoors without specified ventilation system (and properly installed vent pipe).
- NEVER use this pool heater in the home or in partly enclosed areas (such as garages), unless the specified ventilation system is used. If used outdoors, install far from open windows, doors, vents and other openings.
- Pentair strongly recommends that all vents, pipes and exhaust systems be initially and periodically tested for proper operation. This testing can be accomplished by using a hand-held carbon monoxide meter and/or by consulting with a gas professional.
- Pool heaters must be used in conjunction with carbon monoxide detectors installed near the pool heater. The carbon monoxide detectors must be periodically inspected for proper operation so as to insure continued safety. Broken or malfunctioning carbon monoxide detectors must be replaced immediately.

### **WARNING — FOR YOUR SAFETY**

This product must be installed and serviced by a professional service technician, qualified in pool heater installation. Some jurisdictions require that installers be licensed. Check with your local building authority about contractor licensing requirements. Improper installation and/or operation could create carbon monoxide gas and flue gases which could cause serious injury or death. Improper installation and/or operation will void the warranty.

 **WARNING — This heater is equipped with an unconventional gas control valve that is factory set at a pressure of -.2 inches wc.** Improper installation, adjustment, alteration, service or maintenance can cause property damage, personal injury or loss of life. Installation or service must be performed by a qualified installer, service agency or the gas supplier. If this control is replaced, it must be replaced with an identical control.

## **SAFETY INFORMATION (continued)**

- ⚠ WARNING** — **Risk of fire or explosion from incorrect fuel use.** Do not try to run a heater set up for natural gas on propane gas or vice versa. Only qualified service technicians should attempt to convert heater from one fuel to the other. Do not attempt to alter the rated input or type of gas by changing the orifice. If it is necessary to convert to a different type of gas, consult your Pentair dealer. Serious malfunction of the burner can occur which may result in loss of life. Any additions, changes, or conversions required in order for the appliance to satisfactorily meet the application needs must be made by a Pentair dealer or other qualified agency using factory specified and approved parts. The heater is available for use with natural gas only. It is not designed to operate with any other fuels. Refer to the nameplate for the type of gas the heater is equipped to use.
- Use heater only with the fuel for which it is designed.
- ⚠ WARNING** — **Risk of fire or explosion from flammable vapors.** Do not store gasoline, cleaning fluids, varnishes, paints, or other volatile flammable liquids near heater or in the same room with heater.
- ⚠ WARNING** — **Risk of explosion if unit is installed near propane gas storage.** Propane (LP) gas is heavier than air. Consult local codes and fire protection authorities about specific installation requirements and restrictions. Locate the heater away from propane gas storage and filling equipment as specified by the Standard for the Storage and Handling of Liquefied Petroleum Gases, CAN/CSA B149.2 (latest edition) or ANSI/NFPA 58 (latest edition).
- ⚠ WARNING** — **Risk of fire, carbon monoxide poisoning, or asphyxiation if exhaust venting system leaks.** Only qualified service technicians should attempt to service the heater, as leakage of exhaust products or flammable gas may result from incorrect servicing.
- ⚠ WARNING** — **Risk of asphyxiation if exhaust is not correctly vented. Follow venting instructions exactly when installing heater.** Do not use a draft hood with this heater, as the exhaust is under pressure from the burner blower and a draft hood will allow exhaust fumes to blow into the room housing the heater. The heater is supplied with an integral venting system for indoor installation. **Canada:** In Canada, this pool heater can only be installed outdoors or in an enclosure that is not normally occupied and has no openings directly into occupied areas. See Page 24 - 27 for enclosure venting requirements.
- ⚠ CAUTION** — **Label all wires prior to disconnection when servicing controls. Wiring errors can cause improper and dangerous operation. Wiring errors can also destroy the control board.**
- Connect heater to **120 or 240** Volt, 60 Hz., Single Phase power only.
  - Verify proper operation after servicing.
  - Do not allow children to play on or around heater or associated equipment.
  - Never allow children to use the pool or spa without adult supervision.
  - Read and follow other safety information contained in this manual prior to operating this pool heater.

### **⚠ DANGER**

**CARBON MONOXIDE GAS IS DEADLY** – Exhaust from this pool heater contains toxic levels of carbon monoxide, a dangerous, poisonous gas you cannot see or smell.



## GENERAL SPECIFICATIONS

### NOTICE

- Combustion air contaminated by corrosive chemical fumes can damage the heater and will void the warranty.
- The Combination Gas Control Valve on this heater differs from most appliance gas controls. If it must be replaced, for safety reasons replace it only with an identical gas control.
- The heater's access side panels must be in place to provide proper ventilation and to avoid water intrusion. **Do not operate the heater for more than five (5) minutes with the side panels removed.**
- This heater is design tested by CSA International as complying with the Standard for Gas Fired Pool Heaters, ANSI Z21.56/CSA 4.7, and is intended for use in heating fresh water swimming pools or spas.
- The ETi™ 400 Heater is designed for the heating of chlorine, bromine or salt system swimming pools and spas. It should **NOT** be used as a space heating boiler, or general purpose water heater.
- The heater should be located in an area where leakage of the heater or connections will not result in damage to the area adjacent to the heater or to the structure. When such locations cannot be avoided, it is recommended that a suitable drain pan, adequately drained, be installed under the heater. The pan must not restrict air flow.
- The heater may not be installed within 5 ft. (1.5M ) of the inside surface of a pool or spa unless it is separated by a solid fence, wall or other permanent barrier.
- In the United States, installation must be in accordance with local codes and the most recent edition of the National Fuel Gas Code, ANSI Z223.1/NFPA-54. The Code can be obtained from: National Fire Protection Association 1 Batterymarch Park Quincy, MA 02169 [www.nfpa.org](http://www.nfpa.org)
- In Canada, install the heater in accordance with local codes and the most recent edition of the Natural Gas and Propane Installation Code, CAN/CSA B149.1.

## Heater Identification Information (HIN)

To identify the heater, see rating plate on the inner front panel of the heater. There are two designators for each heater, one is the Model Number and the other is the Heater Identification Number (HIN).

### Heater Identification Number (HIN)

The following example simplifies the identification system:

- 1) ETi
- 2) Model Size : (400) : Input rating (Btu/hr)  
X 1000
- 3) Fuel Type : NA = Natural gas
- 4) Construction : ASME = Commercial Model

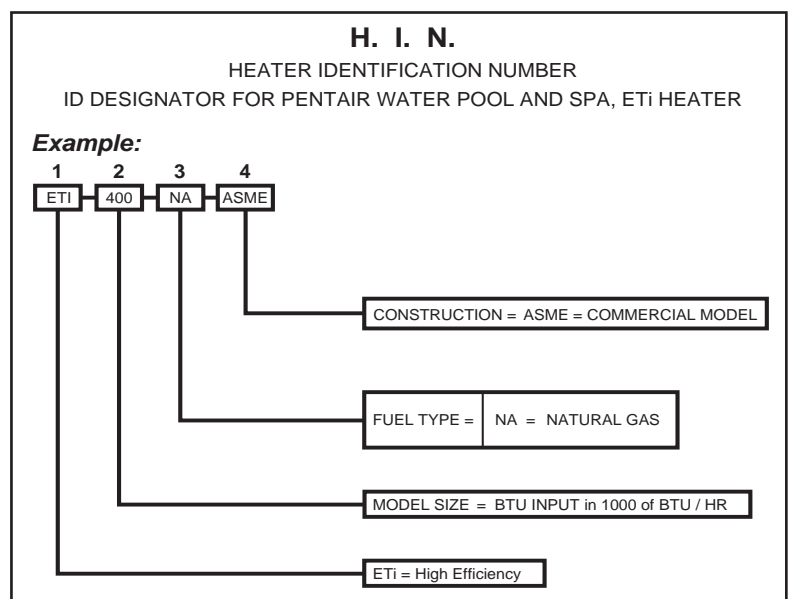

# Section 1: Operation Instructions

## OPERATOR CONTROL PANEL

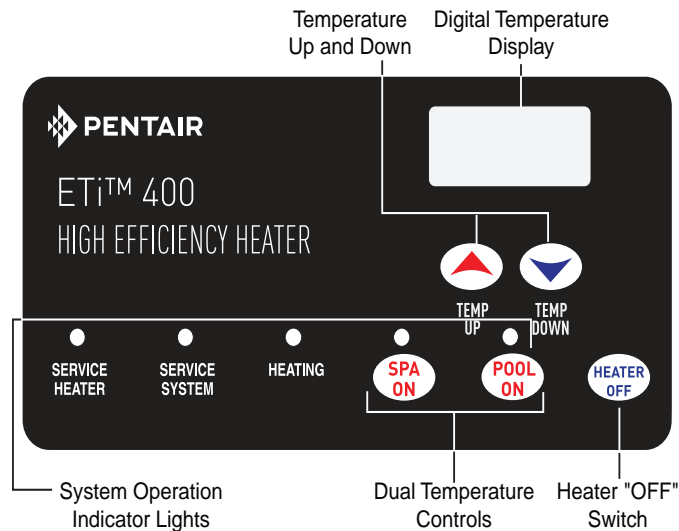

## TEMPERATURE SETTING

The ETi™ 400 Heater is shipped factory set at 70° F (35° C) for pool mode and 95° F (21° C) for spa mode. Using the up and down arrows, you can set the thermostats to a minimum temperature of 65° F (18.3° C), or a maximum of 104° F (40° C). If you desire to heat only one body of water, the thermostat is capable of an off mode.

The heater operator controls are as follows:

- POOL ON** Press this button to control the heater operation by the pool temperature setting.
- SPA ON** Press this button to control the heater operation by the spa temperature setting.
- HEATER OFF** Press this button to switch off the heater.
- ▲ TEMP** Press this button to raise the temperature setting.
- ▼ TEMP** Press this button to lower the temperature setting.

To toggle the display between degrees Centigrade (°C) and degrees Fahrenheit (°F):

1. Press the HEATER OFF button to switch the heater OFF.
2. Press **▲ TEMP** or **▼ TEMP** for 5 seconds. The display will flash once and change modes (°C to °F or vice versa).
3. Press the HEATER OFF button to switch the heater ON.

When either the **▲ TEMP** or **▼ TEMP** buttons are depressed, the digital display will indicate the temperature setting. After five seconds, the display will return to the actual pool/spa temperature.

In addition to the digital temperature display, there are five indicator lights:

The **POOL ON** light indicates the pool water temperature is controlling the heater operation.

The **SPA ON** light indicates the spa water temperature is controlling the heater operation.

The **HEATING** light comes on and stays on when the heater's burner chamber is firing. This light should be on whenever the burner is on. This light blinks when the heater is calling for heat but not firing. If this light is on but the burner fails to come on, one of the "service" lights should come on, indicating a fault in the system.

The **SERVICE SYSTEM** light indicates that there is insufficient water flow to the heater. If the pump is operating, this usually indicates that the filter and/or skimmers should be cleaned (some filters may require back-washing). If the light remains on after the filter/skimmers have been serviced, the system should be checked by a qualified service technician.

The **SERVICE HEATER** light indicates a fault in the heater or its controls. If this light comes on, shut down the heater (See **TO TURN OFF GAS TO THE APPLIANCE on page 13**), and have a qualified service technician check the system.

## **OPERATOR CONTROL PANEL**

**VIEW FAULT CODES:** Press the POOL ON button and the ▲ **TEMP** button to view the last fault code. Press the ▲ **TEMP** button to scroll up to view the previous 4th. fault codes. The next message displayed after the 5th. fault code is END.

**VIEW STACK FLUE GAS TEMPERATURE:** Press and hold the POOL ON (or SPA ON) button for more than 5 seconds to view the current Stack Flue Gas temperature. Each heat exchange has one temperature sensor (SF1 and SF2), the SF1 temperature is displayed on the heater's LCD with a dot on the upper left corner of the LCD. Scroll up or down to display the SF2 current temperature and the dot will not be displayed on the LCD.

## **BASIC SYSTEM OPERATION**

Start the pump. Be sure the pump is running and primed to close the water pressure switch and supply power to heater. Be sure the pool and/or spa is properly filled with water. Follow the Lighting/Operating instructions below.

### **⚠ WARNING**

Risk of explosion or fire causing burns or death if safety interlocks are disabled. DO NOT attempt to operate heater when SERVICE HEATER light is on or if blower or burner will not start. Instead, follow instructions under "To Switch Off Gas to the Appliance," and call a qualified service technician to repair unit.

## **HEATER DSI ELECTRONIC IGNITION LIGHTING/OPERATION**

### **FOR YOUR SAFETY: READ BEFORE LIGHTING**

### **⚠ WARNING**



If you do not follow these instructions exactly, a fire or explosion may result causing property damage, personal injury or loss of life.

Do not attempt to light the heater if you suspect a gas leak. Lighting the heater can result in a fire or explosion which can cause personal injury, death, and property damage.

---

## **BASIC SYSTEM OPERATION (CONTINUED)**

---

### **START-UP AND OPERATION**

**START-UP AND SHUTDOWN INSTRUCTIONS ARE ON THE LABEL ATTACHED TO THE INSIDE COVER OF THE APPLIANCE WATER CONNECTION PANEL.**

#### **BEFORE START-UP**

- A. This appliance does not have a pilot. It is equipped with an ignition device which automatically lights the burners. **DO NOT** try to light the burners by hand.
  - B. **BEFORE OPERATING**, smell all around the appliance area for gas. Be sure to smell next to the floor because some gas is heavier than air and will settle on the floor.
- WHAT TO DO IF YOU SMELL GAS**
- Do not try to light any appliance.
  - Do not touch any electrical switch; do not use any phone in your building.
  - Immediately call your gas supplier from a neighbor's phone. Follow the gas supplier's instructions.
  - If you cannot reach your gas supplier, call the Fire Department.
- C. Use only your hand to turn the gas control on or off. Never use tools. If you cannot change the ON/OFF setting by hand, don't try to repair it, call a qualified service technician. Forced or attempted repair may result in a fire or explosion.
  - D. Do not use this heater if any part has been under water. Immediately call a qualified service technician to inspect the heater and to replace any part of the control system and any gas control which has been under water.
  - E. Do not operate the pool heater unless the pool or spa is properly filled with water.
  - F. Before operating the appliance for the first time or after it has been off for an extended time, perform the following checklist:
    1. Remove debris or other articles from inside the heater and the area around the heater and its exhaust vent. Make sure the ventilation openings are clear of debris or obstruction. For installations in an enclosed space, make sure openings for combustion and ventilation air are unobstructed.
    2. Keep heater area clear and free from combustibles, flammable liquids and chemicals.
    3. Check that all water connections are tight.
    4. Water must be flowing through the heater during operation. Make sure that pool/spa is filled with water and have pump operating. Check that water flow is unobstructed from the appliance. When operating for the first time or after an extended shut-down, run filter pump for several minutes to clear all air from the system.

---

### **PUTTING THE HEATER INTO SERVICE**

---

If the heater's **Water Pressure Switches (PS)** are below or above the water level by 3 ft (61 cm), after the heater installation the Water Pressure Switch setting should be adjusted. **See WATER PRESSURE SWITCH, in SAFETY CONTROLS on page 14.**

**Note: Before putting the heater into service for the first time, follow the instructions under BEFORE START-UP on page 12. Check for proper operation of the heater by following the steps under OPERATING INSTRUCTIONS on page 13. Damage to equipment caused by improper installation or repair will void the warranty.**

## HEATER OPERATING INSTRUCTIONS

1. **STOP!** Read the safety information on (page 12).
2. Set both pool and spa thermostats to the lowest settings.
3. Turn off all electric power to the appliance.
4. This appliance does not have a pilot. It is equipped with an ignition device which automatically lights the burner. Do not try to light the burner by hand.
5. Remove the access door panels by unfastening the latch located on each door, then lift up and out from the bottom of the panel to remove.
6. **Toggle-Style Valve:** Pull toggle toward you to turn gas off, see Figure 1.
7. Wait five (5) minutes to clear out any gas. If you then smell gas, **STOP! Follow B in the BEFORE START-UP instructions on page 12. If you don't smell gas, go to the next step.**
8. Push the toggle switch away from you to switch the gas on.
9. Replace the Door Access Panels. All panels must be in place when operating the heater.
10. Set 3-way valves on inlet and outlet to pool or spa, as appropriate.
11. Turn on all electric power to the appliance.
12. Press either the POOL ON or SPA ON button switch on the operating control.
13. Set the thermostat to desired setting. **NOTICE: Setpoint must be above actual water temperature or burner will not fire. See OPERATOR CONTROL PANEL on page 11.**
14. The blower should come on immediately, and after about 15 seconds, the burner should fire. When operating for the first time, the burner may not fire on the first try because of air in the gas line. If it does not fire at first, push the OFF switch, wait five minutes, and again push the POOL or SPA ON switch. The burner should fire after about 15 seconds. You may have to repeat this until all of the air has cleared the gas line.
15. The burner should fire until the pool/spa temperature reaches the desired temperature set on the thermostat. The blower will continue to run for about 45 seconds after the burner shuts off. If any of the safety interlocks should open during burner operation, the burner shuts off immediately, but the blower continues to run for about 45 seconds. Should overheating occur or the gas supply fail to shut off, turn off the manual gas control valve to the appliance.
16. If the appliance will not operate, follow the instructions **TO TURN OFF GAS TO THE APPLIANCE** below, and call your service technician or gas supplier.
17. If the electrical power is shut off to the heater while it is running, once power is restored, the heater will power up with the previous programmed settings.

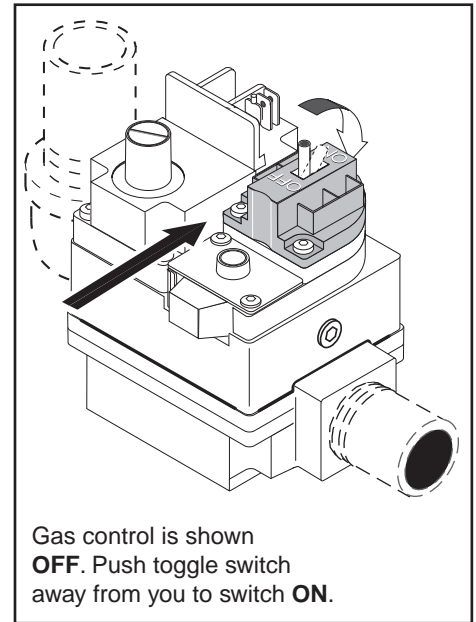

Figure 1.

## TO TURN OFF GAS TO APPLIANCE

1. Press the OFF button on operating control.
2. Switch off all electric power to the unit.
3. Remove the access door panels.
4. **Toggle-Style Valve:** Pull toggle toward you to turn gas off, see Figure 1 on page 13.
5. Replace the Access Door Panels.

## SAFETY CONTROLS

### AIR FLOW SWITCH (AFS)

There are two air flow switches, (see Figure 2), designed as a safety device to ensure the two combustion air blowers (fans) are operating and are monitoring the differential (negative) pressure within the blower housing. These air pressure switches are factory set. The switches (see page 61 #29) are connected upstream of the ignition module. The ignition module does not operate unless the air flow switches and all safety switches are closed.

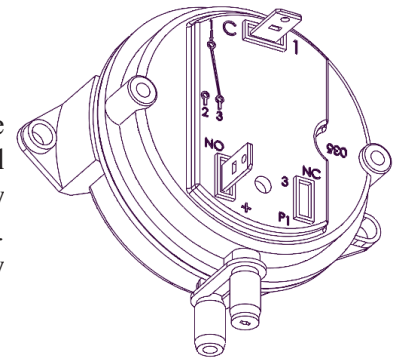

Figure 2. Air Flow Switch

### WARNING

## WARNING

**Hazardous pressure. Do not bypass the Water Pressure Switches or render it inoperable.**

The heater has two Water Pressure switches, see Figure 3. If the water flow is restricted, the water pressure switches may prevent the burner from firing and cause the Service System LED indicator to go on. **Note: If the light remains on after the filter has been serviced, have a qualified service technician check the system.**

For deck-level heater installations, the Water Pressure switches are factory set at 3.00 psi (20.6 kPa). **Note: See Below Pool Level Installation, on page 20.** If the pressure switches are 1 ft (0.3M) below or above the pool water level, reset the switches so that it is open when the pump is off and closed when the pump is running. Turn the star-wheel on the switch clockwise (↻) to raise setting (heater below the pool level) and counterclockwise (↺) to lower the setting (heater above the pool level), see Figure 4. Test each switch after resetting.

**NOTICE:** When the heater is mounted more than 3 ft (0.9 m) above or 3 ft (0.9 m) below the deck level, a pressure switch is no longer adequate. A Flow Switch must be installed instead.

**CAUTION!** Heater operation with an incorrect water pressure switch setting, may cause the heater to operate without sufficient water flow, and may cause severe heater damage.

### HIGH LIMIT SWITCH AND AUTOMATIC GAS SHUT-OFF SWITCHES (AG1 AND AG2)

A High Limit Switch (HLS), is a safety device that opens the electrical circuit and shuts off the heater based on a water temperature set point within the HLS. The heater contains two AGS switches and one HLS switch. The AGS switches are located in the outlet plumbing assembly, and the HLS switch is located on the main Inlet/Outlet Header (see page 16).

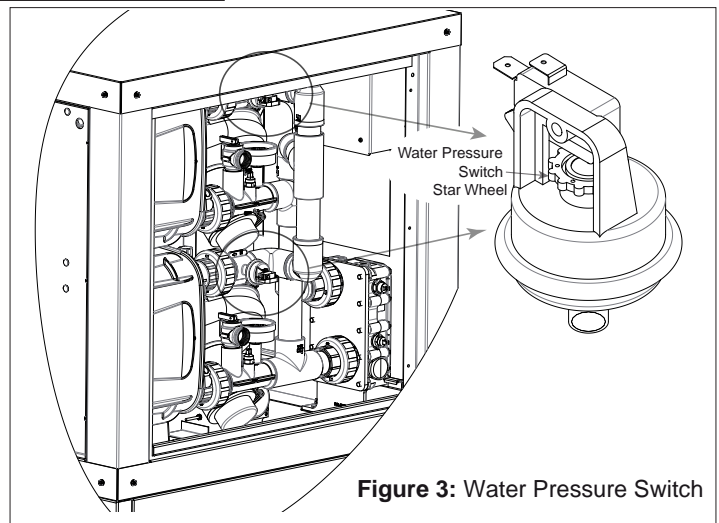
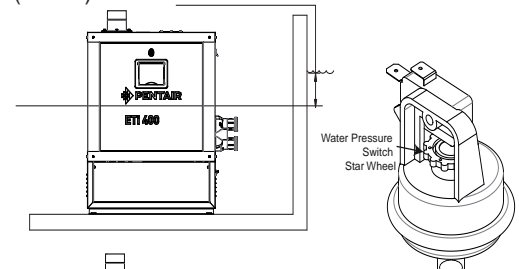

Figure 3: Water Pressure Switch

Turn star wheel **clockwise** to raise pressure set point if water pressure switch is more than 1 ft (30 cm) below water level



A reference scale is on the back of pressure switch

Turn star wheel **counterclockwise** to lower pressure set point if pressure switch is more than 1 ft (30 cm) above water level

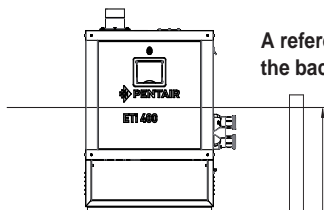

Figure 4.

## **SAFETY CONTROLS (continued)**

### **STACK FLUE SENSORS (SF1, SF2)**

The heater is equipped with two Stack Flue sensors; one for each heat exchanger. These sensors monitor the stack flue temperature and if needed will shut down the heater if the stack flue temperature exceeds 170° F (77° C).

### **THERMAL FUSE**

A Thermal Fuse (TF) is a safety protection device that opens the electrical circuit if the temperature reaches 187° F (86° C). The fuse cannot be reset, it must be replaced. See page 17 for more information.

### **FLOAT SWITCH**

The Float Switch (FS) is a sensing application that shuts down the heater once the condensate level exceeds the permitted level in the condensate container. See page 17 for more information.

## **IGNITION MODULE OPERATION**

The Ignition Module, (Figure 5), is microprocessor based and operates on 24VAC supplied by the transformer. The control works in conjunction with a fan control board (Figure 6), and utilizes a microprocessor to continually safely monitor, analyze, and control the proper operation of the gas flame holder. The module with the presence of the flame sensor, using flame rectification, allows the heater to operate.

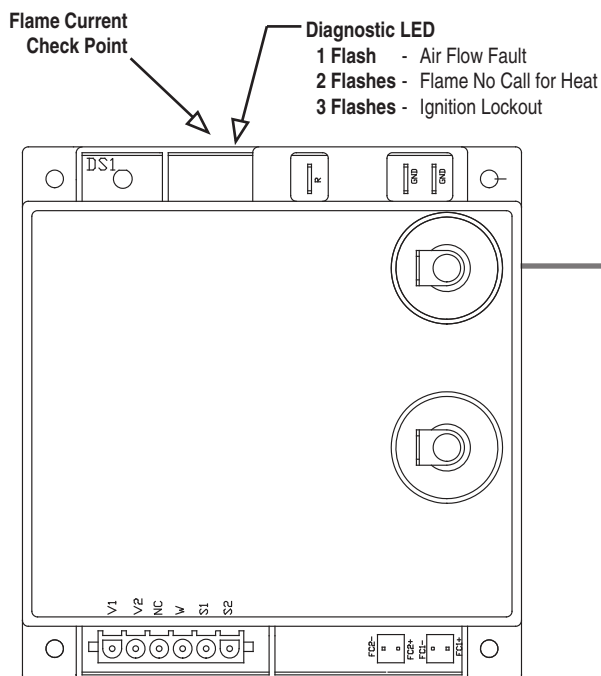

**Figure 5. Ignition Control Module**

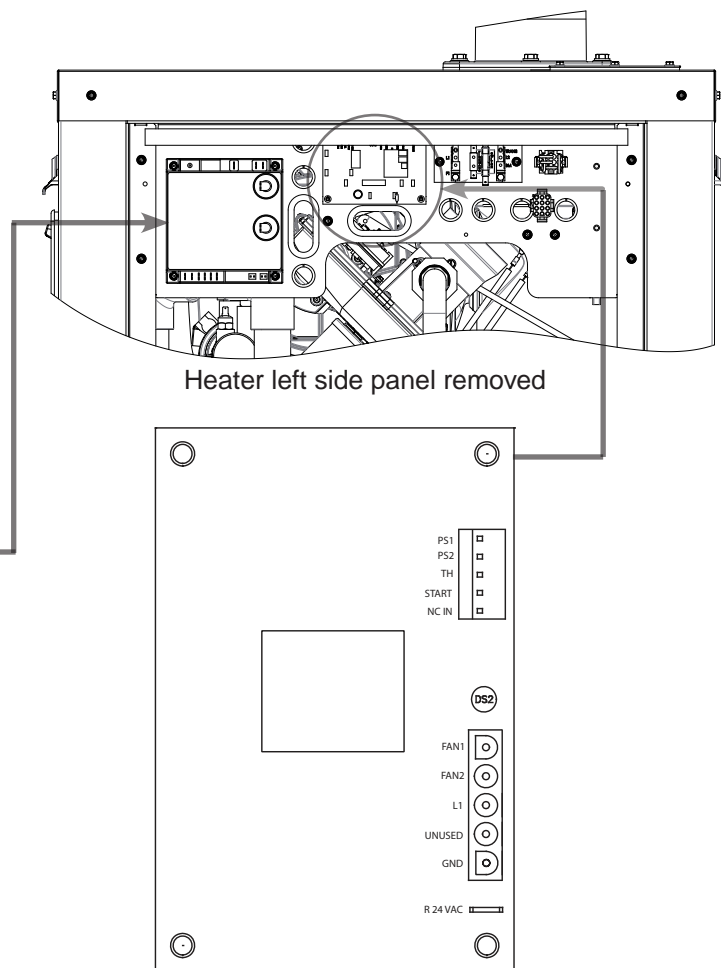

**Figure 6. Fan Control Circuit**

# Section 2: Installation Instructions

**THIS HEATER MUST BE INSTALLED AND SERVICED BY A PROFESSIONAL SERVICE TECHNICIAN, QUALIFIED IN POOL HEATER INSTALLATION.**

Pentair strongly recommends that all vents, pipes and exhaust systems be initially and periodically tested for proper operation. This testing can be accomplished by using a **hand-held carbon monoxide meter** and/or by consulting with a gas professional. Pool and spa heaters must be used in conjunction with **carbon monoxide detectors** installed near the pool heater. The carbon monoxide detectors must be periodically inspected for proper operation so as to insure continued safety. Broken or malfunctioning carbon monoxide detectors must be replaced immediately.

## HEATER DESCRIPTION

The ETi™ 400 Heater has precisely matched orifice plates to meter the air and gas into the mixer. The blower draws the air and gas through the mixer and forces it into the burner's flame holder. A sealed TitanTough™ Heat Exchanger surrounds the flame holder, discharging exhaust gases out the flue (See Figure 7 & 8). **Use a 2 in fitting to connect to the 2 in PVC slip unions provided with the heater.** The outer manifold remains cool; no heat sinks are required. The heater operator control panel is located on the side of the heater.

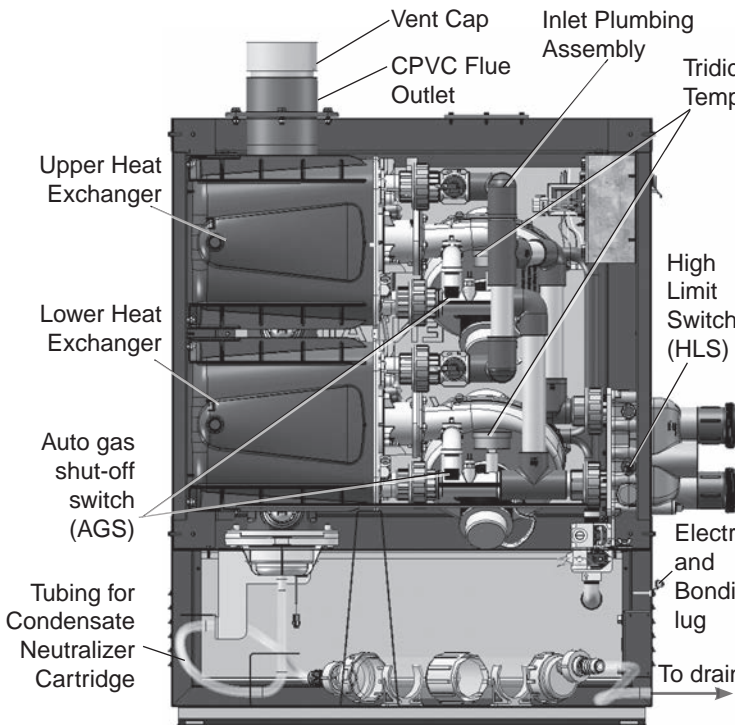

Figure 7. ETi™ 400 Heater (Left Side View)

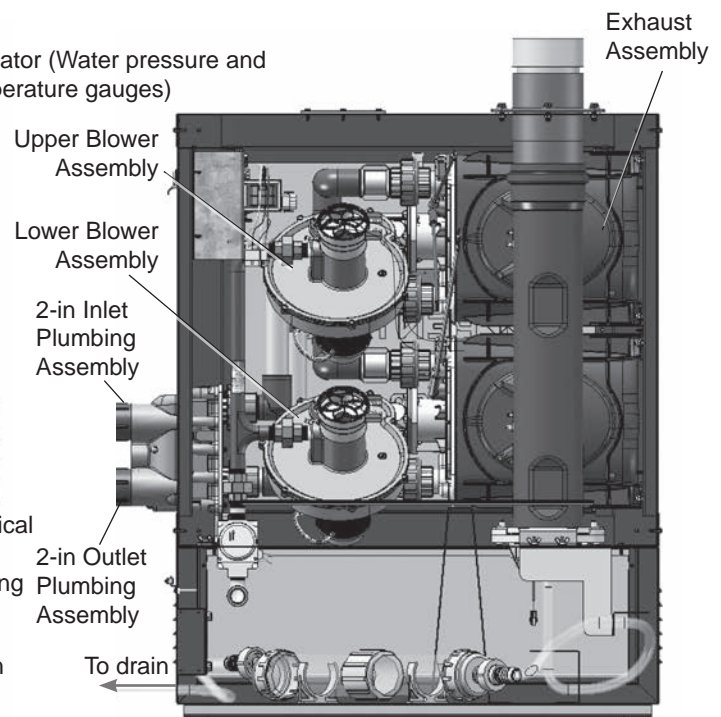
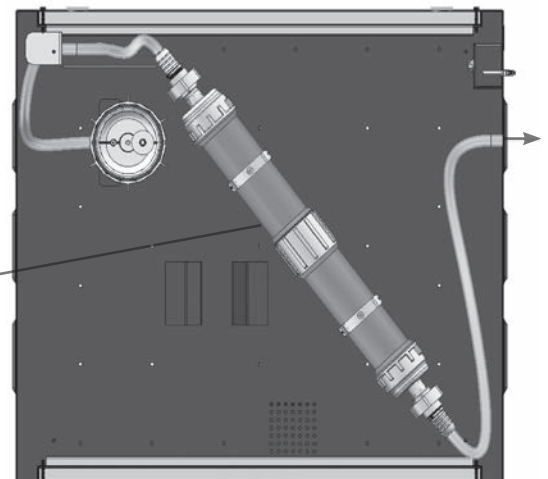

Figure 8. ETi™ 400 Heater (Right Side View)

Condensate Neutralizer Cartridge (Optional, P/N 475612 sold separately). The cartridge may be mounted onto the heater base for heater outdoor installation.



Heater Base (Top View)



## SEQUENCE OF OPERATION

An electronic temperature sensing **thermistor** in the manifold adapter inlet controls the heater operation. When the inlet water temperature drops below the temperature set on the **operator control panel**, the **control board** supplies power to the combustion **air blowers** through a series of **safety interlocks**. The heater interlocks consist of:

- the **two water pressure switches (PS)**, which senses that the pump is running,
- the **tridicator gauges (2)** which monitors the water temperature in degree Fahrenheit and pressure in psi.
- the **high limit switch (HLS)**, which opens if the heat exchanger outlet temperature goes above 135° F (57° C), and
- the **two air flow switches (AFS)**, sense the pressure drop across the air metering orifices.
- the **two thermal fuses (TF)** open if the flue gas temperature reaches 187° F (86° C).
- the **automatic gas shut-off (AG1, AG2)** switches, which open if the heat exchanger outlet temperature goes above 150° F (66° C).
- the **float switch (FS)** which opens if the condensate overflows at the float switch due to blockage in the condensate drain hose or neutralizer cartridge.
- the **stack flue sensors (SF1, SF1)**, which shut down the heater if the flue gas temperature reaches 170° F (77° C).

The air flow switches (AFS) sense the pressure differential between both of the air metering orifices. As soon as there is sufficient air flow, the AFS closes, completing the circuit to the Fan Control board. The gas ignition control then opens the gas valve and the fuel mixture is ignited by the Direct Spark Ignition (DSI). On a call for heat, the blowers are energized for 15 seconds, the gas valve opens simultaneously as the direct spark igniters are energized, then ignition occurs. The heater is equipped with a digital operating control that enables the user to pre-set the desired pool and spa water temperatures. The control enables the user to select between pool and spa heating, and features a digital display

## SPECIFICATIONS

The installation instructions contained in this manual are designed for use by qualified personnel only, trained especially for installation of this type of heating equipment and related components. Some states require installation and repair by licensed personnel. If this applies in your state, be sure your contractor bears the appropriate license. See Figure 9, 10 & 11 for Outdoor and Indoor installations, dimensions and orientation of the heater.

### Dimensions in Millimeters / Inches

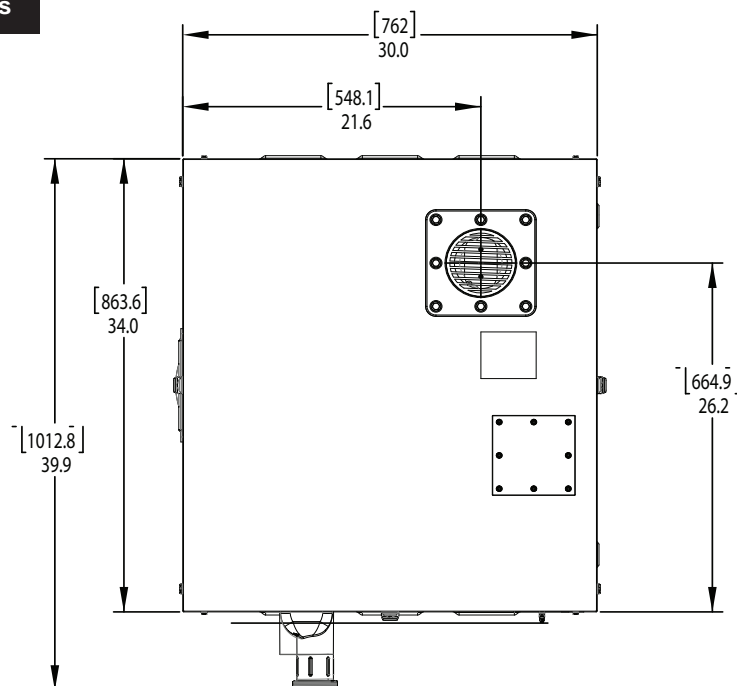

Figure 9. Heater Top View

# SPECIFICATIONS (CONTINUED)

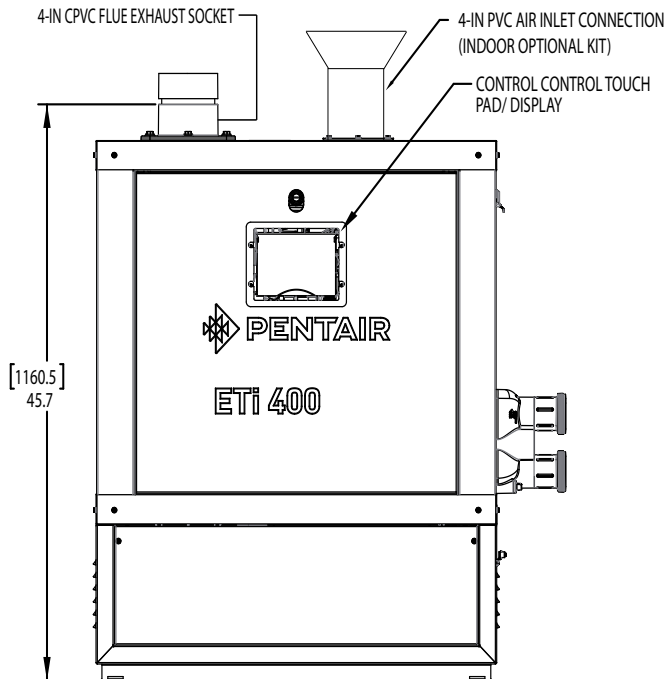

Figure 10.

Heater Front View

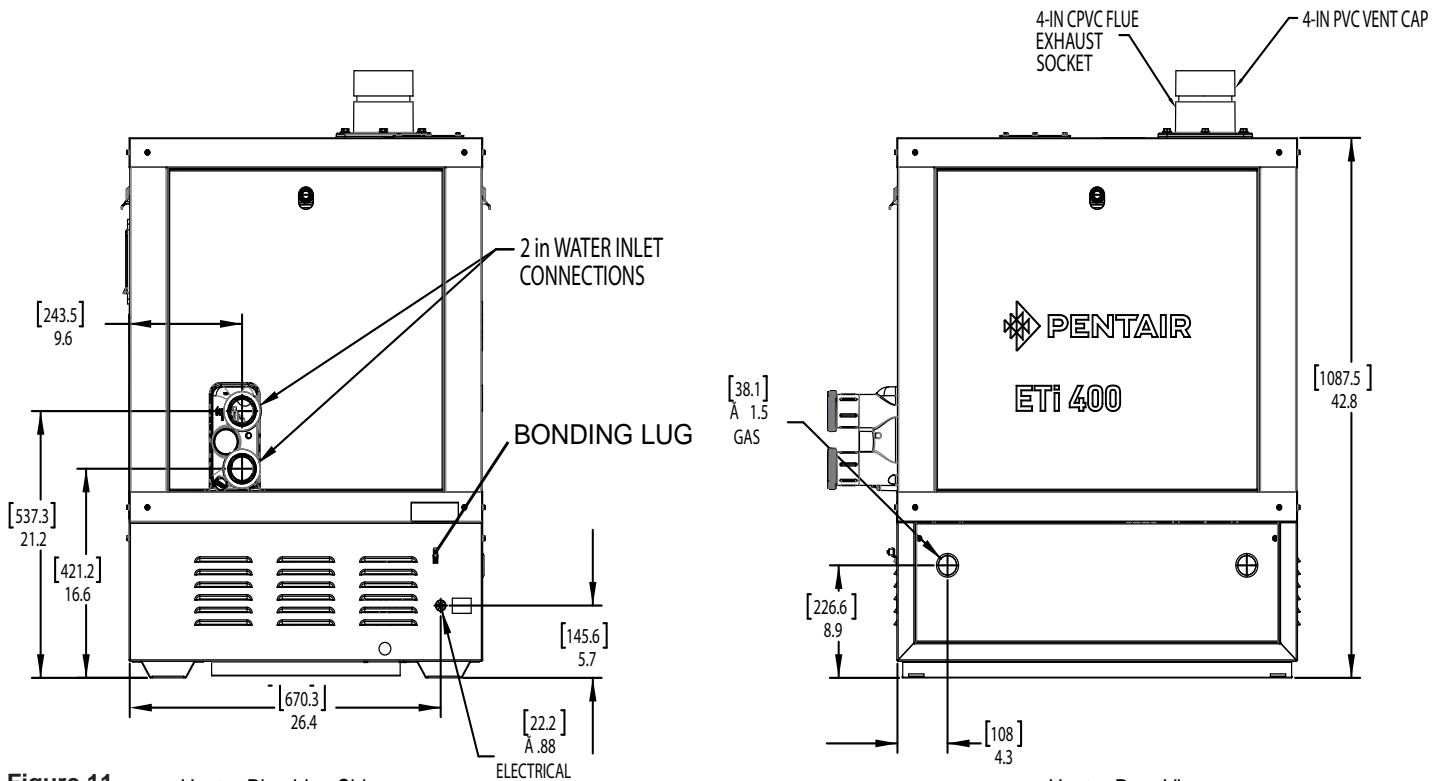

Figure 11.

Heater Plumbing Side

Heater Rear View

## PLUMBING CONNECTIONS

The heater has the unique capability of direct schedule 40 PVC plumbing connections. A set of bulkhead fittings is included with the heater to ensure conformity with Pentair's recommended PVC plumbing procedure. Other plumbing connections can be used. See Figure 12 for plumbing connections.

### CAUTION

Before operating the heater on a new installation, turn on the circulation pump and bleed all the air from the filter using the air relief valve on top of the filter. Water should flow freely through the heater. Do not operate the heater unless water in the pool/spa is at the proper level. If a manual by-pass is installed, temporarily close it to ensure that all air is purged from the heater.

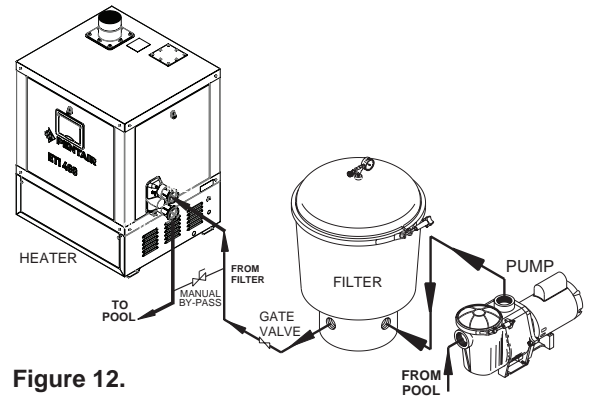

Figure 12.

## WATER CONNECTIONS

The heater requires proper water flow and pressure for its operation. See Figure 13 for the recommended installation. The filter pump discharges to the filter, the filter discharges to the heater, and the heater discharges directly to the pool or spa.

A manual bypass valve should be installed before the heater when the pump flow exceeds 120 GPM (454 LPM). See **WATER FLOW RATE Table 1 on page 20** for setting of the manual by-pass valve.

Make sure that the outlet plumbing from the heater contains no shut-off valves or other flow restrictions that could prevent flow through the heater (except for pool installations as noted below, or winterizing valves where needed). To switch flow between the pool and spa, use a diverter valve. Do not use any valve that can shut off the flow.

Install the chemical feeder downstream of the heater. Install a chemical resistant one-way check valve between the heater and the chemical feeder to prevent back-siphoning through the heater when the pump is off.

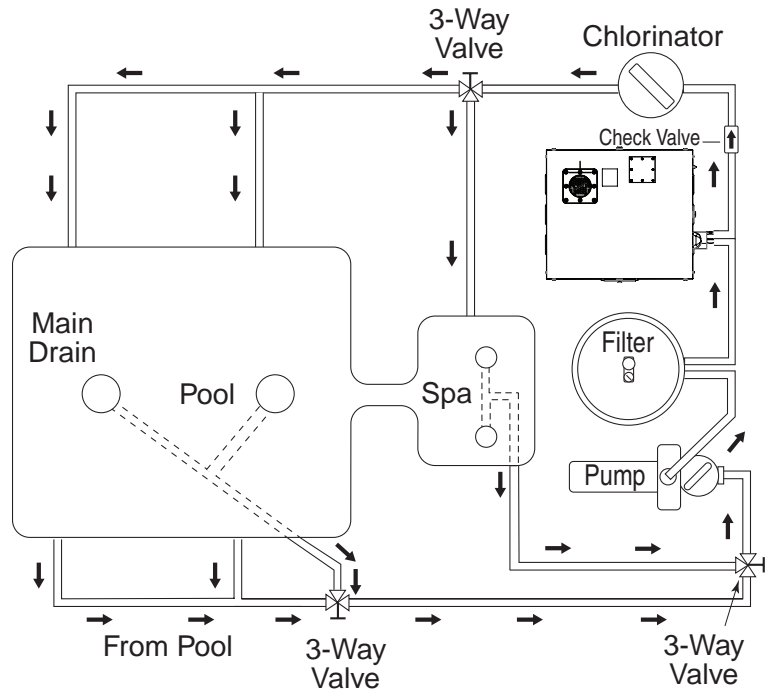

Figure 13.

**NOTICE:** If the heater is plumbed in backwards, it will cycle continuously. Make sure piping from filter is not reversed when installing heater.

Connect the heater directly to 2 in PVC pipe, using the provided unions. Heat sinks are not required. The low thermal mass of the heater will prevent overheating of the piping connected to the pump even if the heater shuts down unexpectedly.

Occasionally a two-speed pump will not develop enough pressure on the low speed to operate the heater. In this case, run the pump at high speed only to operate the heater. If this does not solve the problem, do not try to run the heater. Instead, correct the installation.

Do not operate the heater while an automatic pool cleaner is also operating. If the circulation pump suction is plugged (for example by leaves), there may not be adequate flow to the heater. Do not rely on the pressure switch in this case.

## VALVES

When any equipment is located below the surface of the pool or spa, valves should be placed in the circulation piping system to isolate the equipment from the pool or spa. Check valves are recommended to prevent back-siphoning. Back-siphoning is most likely to occur when the pump stops, creating a pressure-suction differential. Do **NOT** sanitize the pool by putting chlorine tablets or sticks into the skimmer(s). When the pump is off, this will cause a high concentration of chlorine to enter the heater, which could cause corrosion damage to the heat exchanger.

### CAUTION

Exercise care when installing chemical feeders so as to not allow back siphoning of chemical into the heater, filters or pump. When chemical feeders are installed in the circulation of the piping system, make sure the feeder outlet line is down stream of the heater, and is equipped with a positive seal noncorrosive Check Valve, (P/N R172288), between the feeder and heater.

## MANUAL BY-PASS

Where the water flow rate exceeds the maximum 120 GPM, a manual bypass should be installed. After installing the valve, adjust the valve to bring the flow rate within the acceptable range. Then remove the valve handle or lock it in place to avoid tampering. See Figure 14.

Table 1: Heater Water Pressure.

ETi™	GPM (min. / max)	Max. $\Delta T$ (°F) / Min $\Delta T$ (°F)
400	40 / 120	35 / 25*

(\*) Compare  $\Delta T$  by observing the Temperature Pressure gauges located inside the heater (see page 16), and the water inlet temperature displayed on the Control Board LCD.

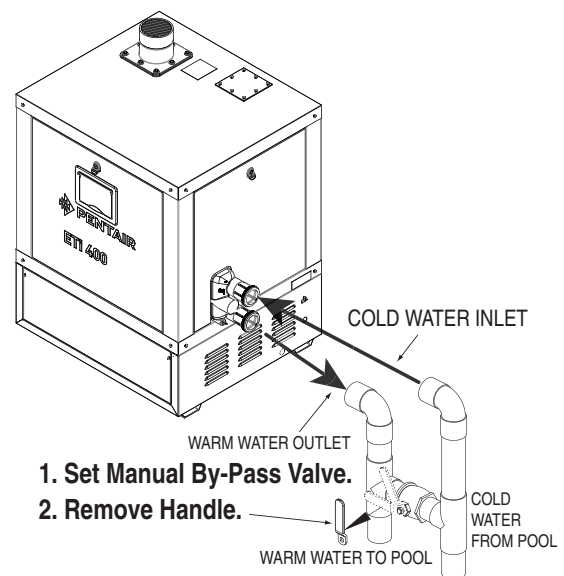

Figure 14.

## BELOW POOL INSTALLATION

If the heater is below water level, the pressure switch must be adjusted. This adjustment must be done by a qualified service technician. See following **CAUTION** before installation.

### CAUTION

#### BELOW OR ABOVE POOL INSTALLATION

The water pressure switch is set in the factory at 3.00 PSI ( $\pm 0.75$  PSI). This setting is for a heater installed at pool level. If the water pressure switch is more than 1 ft (30 cm) below or above the pool level, the water pressure switch must be adjusted by a qualified service technician. Figure 4 on page 14.

#### FLOW SWITCH

If the water pressure switch is installed more than 3 ft (0.9 m) above the pool or more than 3 ft (0.9 m) below the pool level, you will be beyond the limits of the pressure switch and a flow switch must be installed. Locate and install the flow switch externally on the outlet piping from the heater, as close as possible to the heater. Connect the flow switch wires in place of the water pressure switch wires.

## **GAS CONNECTIONS**

### **GAS LINE INSTALLATIONS**

Before installing the gas line, be sure to check which gas the heater has been designed to burn. This is important because different types of gas require different gas pipe sizes. The rating plate on the heater will indicate which gas the heater is designed to burn. The Table 2 below, show which size pipe is required for the distance from the gas meter to the heater. The table description is for natural gas at a specific gravity of 0.60, and propane gas at a specific gravity of 1.50.

When sizing gas lines, calculate three (3) additional feet of straight pipe for every elbow used. When installing the gas line, avoid getting dirt, grease or other foreign material in the pipe as this may cause damage to the gas valve, which may result in heater failure.

*The gas meter should be checked to make sure that it will supply enough gas to the heater and any other appliances that may be used on the same meter. The gas line from the meter will usually be of a larger size than the gas valve supplied with the heater. Therefore a reduction of the connecting gas pipe will be necessary. Make this reduction as close to the heater as possible.*

The heater requires a gas supply of not less than 4 in (10.2 cm) wc, and not more than 10.5 in (27 cm) wc for natural gas, and not more than 14 in (36 cm) wc for propane gas. Gas supply pressures outside of this range may result in improper burner operation. A minimum flowing or dynamic inlet pressure (while the heater is running) of 4 in (10.2 cm) wc is required to maintain input rating with no more than a 2 in pressure drop between static and dynamic. The gas supply must be installed in accordance with the *National Fuel Gas Code, ANSIZ223.1*, or standard *CSA B149.1, Natural Gas and Propane Installation Codes*, as applicable and all applicable local codes. Install a manual shut-off valve and a sediment trap and union located outside the heater panels, see Figure 15. Do not use a restrictive gas cock. The following minimum gas pipe sizes are recommended for natural gas supply piping, see Table 2 on below. For low pressure LP gas, pipe size may be reduced by 1/4-in, with a minimum pipe size of 1/2-in. Check for compliance with local codes.

The heater and any other gas appliances must be disconnected from the gas supply piping system during any pressure testing on that system, (greater than 1/2 PSI). The heater and its gas connection must be leak tested before placing the heater in operation. **Do not use flame to test the gas line.** Use soapy water or another nonflammable method.

#### **NOTE**

**A manual main shut-off valve must be installed externally to the heater.**

### **WARNING**

**DO NOT INSTALL THE GAS LINE UNION INSIDE THE HEATER CABINET. THIS WILL VOID YOUR WARRANTY.**

## **GAS PIPE SIZING**

### **STAGE TWO LOW PRESSURE GAS PIPE SIZING**

Maximum Equivalent Pipe Length (ft)									
Natural Gas 1000 BTU/FT <sup>3</sup> 0.60 Specific Gravity at 0.5 in. WC Pressure Drop									
Propane Gas 2500 BTU/FT <sup>3</sup> 1.50 Specific Gravity at 0.5 in. WC Pressure Drop									
	Input	3/4"		1"		1-1/4"		1-1/2"	
Model	(KBTU)	N	P	N	P	N	P	N	P
ETi™ 400	399.0	*	20	20	60	90	220	200	450

Table 2: Note (\*) A 3/4" gas line can be used for up to 2 ft (61 cm) maximum length from the gas valve in addition to the sediment trap.

## **GAS PRESSURE TESTING**

Before operating the heater, the heater and its gas connections must be leak tested. **Do NOT use an open flame to test for leaks.** Test all gas connections for leaks with soapy water or another non-flammable method.

The heater and its individual shut-off valve must be disconnected from the gas supply piping system during any pressure testing of that system at test pressures in excess of 1/2 psig (3.5 kPa). The heater must be isolated from the gas supply system by closing its individual manual shut-off valve during any pressure testing of the gas supply at test pressures equal to or less than 1/2 psig (3.5 kPa).

**⚠ Caution:** The heater and its manual shut-off valve must be disconnected from the gas supply during any pressure testing of that system at test pressures in excess of 1/2 psi (3.45 Kpa). Dissipate test pressure in the gas supply line before reconnecting the heater and its manual shut off valve to gas supply line. Failure to follow this procedure may damage the gas valve. Over pressurized gas valves are not covered by warranty. The heater and its gas connections shall be leak tested before placing the appliance in operation. Use soapy water for leak test. Do not use open flame.

**Note: do not use threaded seal tape on gas line pipe thread.** A pipe compound rated for use with natural and propane gases is recommended. Apply sparingly only on male pipe ends, leaving the two end threads bare.

**Special safety and precautions for LP gas:** If proper ventilation is not provided gas can collect or *pool* in enclosed areas, because LP gas is heavier than air. Pentair does not recommend installing the heater in an enclosed areas, such as a ground pit. If the heater is required to be installed in an enclosed area, be sure proper ventilation for LP gas are met and locate the heater a safe distance from LP gas cylinders and filling equipment. Before installation, consult the national fuel gas code (nfpa 54 / ansi z223.1, Latest edition), the natural gas and propane installation code in Canada (can/csa b149.1, Latest edition), and any other local codes and fire protection authorities about specific installation restrictions in your location.

## **SEDIMENT TRAPS**

Install a sediment trap and union located outside the heater panels in accordance with National code requirements. Do not use a restrictive gas cock. The sediment trap shall be either a tee fitting with a capped nipple in the bottom outlet which can be removed for cleaning, as shown in Figure 15, or an other device recognized as an effective sediment trap. All gas piping should be tested after installation in accordance with local codes.

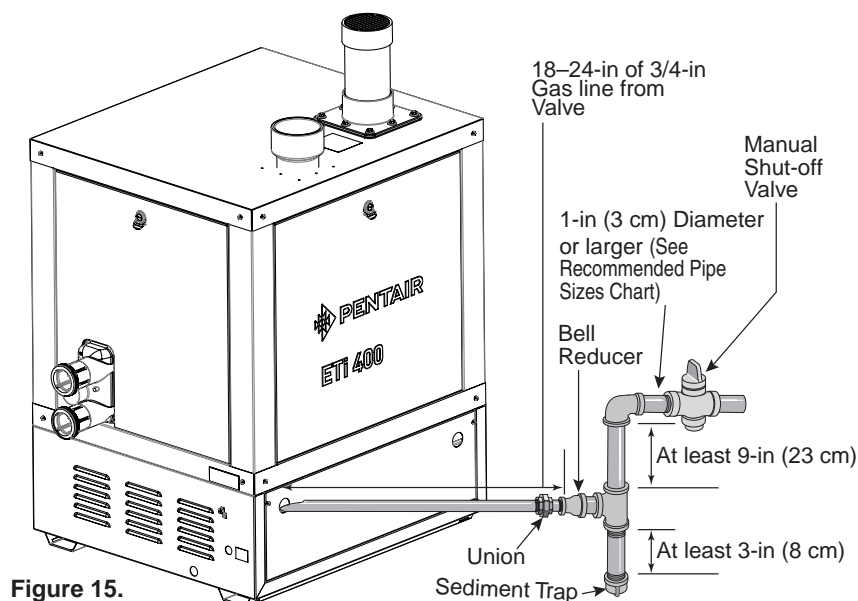

Figure 15.

## OUTDOOR HEATER INSTALLATION (U.S. and Canada)

The heater is designed and certified for outdoor installation using the 2 ft (61 cm) long vent pipe stack.

### ⚠ WARNING

**Risk of explosion if a unit burning propane gas is installed in a pit or other low spot.** Propane is heavier than air. Do not install the heater using propane in pits or other locations where gas might collect. Consult your local building code officials to determine installation requirements and specific installation restrictions of the heater relative to propane storage tanks and filling equipment. Installation must meet the requirements for the Standard for the Storage and Handling of Liquid Petroleum Gases, ANSI/NFPA 58 (latest edition) in the U.S., or CAN/CSA B149.2 (latest edition) in Canada. Consult local codes and fire protection authorities about specific installation restrictions.

The heater is designed for outdoor operation in **non-freezing conditions only**. During freezing conditions the condensate drain line and trap may freeze, causing the heater to shut down due to a blocked condensate drain. Also, the heater condensate system components may be damaged by the ice forming on the condensate drain line and trap. If the heater is installed in freezing climates for seasonal use, winterize the heater to avoid freeze damage. See Winterizing Instructions on page 53. Locate the heater on a level surface in an open area that is protected from drainage or run-off. Install the heater in an area where leaves or other debris will not collect on or around the heater. To avoid damage to the electronic components in the heater, take care to prevent prolonged exposure to driving sources of water (such as lawn sprinklers, heavy roof runoff, hoses, etc.). Avoid operation in persistent, extreme, moist or salty environments.

**⚠ CAUTION!** In an outdoor installation it is important to ensure water is diverted from overhanging eaves with a proper gutter/drainage system. **CAUTION!** If the heater is installed directly under a roof overhang, install a 90° street elbow onto the vent terminal. Install a 2 ft (61 cm) pipe section onto the elbow. Install the vent cap onto the end of the pipe. Direct the vent cap away from the house or building, (see illustration below).

### OUTDOOR INSTALLATION VENTING GUIDELINES

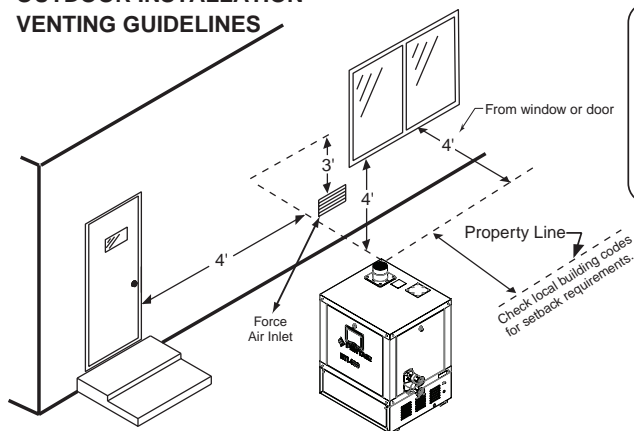

#### Vent Termination:

- Must be at least 3 ft. above any forced air inlet located within a 10 ft. radius.
- Must be located 6 in. away from the building wall and the following distances away from any building wall openings, included but not limited to vented eaves, doors, windows, gravity air inlet:
  - 4 ft. below,
  - 4 ft. horizontally

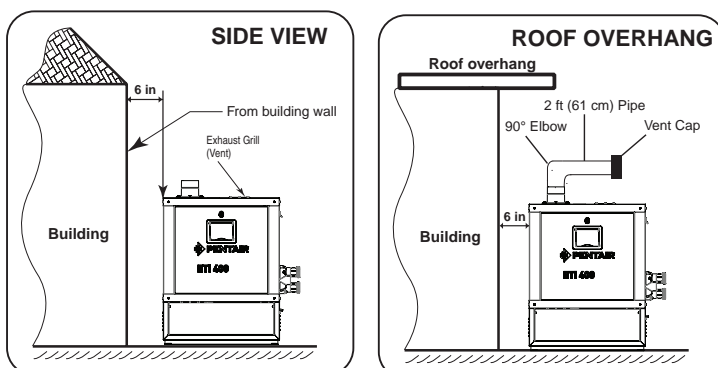

Figure 16.

## OUTDOOR HEATER INSTALLATION (CONTINUED)

The following information is for heaters located outdoors, using a 2 ft (61 cm) long vent pipe stack.

### ⚠ WARNING

**CARBON MONOXIDE GAS IS DEADLY** – Exhaust from this pool heater contains carbon monoxide, a dangerous, poisonous gas you cannot see or smell. Symptoms of carbon monoxide exposure or poisoning include dizziness, headache, nausea, weakness, sleepiness, muscular twitching, vomiting and inability to think clearly. IF YOU EXPERIENCE ANY OF THE ABOVE SYMPTOMS, IMMEDIATELY TURN OFF THE POOL HEATER, LEAVE THE VICINITY OF THE POOL OR SPA AND GET INTO FRESH AIR IMMEDIATELY. THE POOL HEATER MUST BE THOROUGHLY TESTED BY A GAS PROFESSIONAL BEFORE RESUMING OPERATION.

**EXCESSIVE CARBON MONOXIDE EXPOSURE CAN CAUSE BRAIN DAMAGE OR DEATH.**

### ⚠ WARNING

**Risk of explosion if a unit burning propane gas is installed in a pit or other low spot.** Propane is heavier than air. Do not install the heater using propane in pits or other locations where gas might collect. Consult your local building code officials to determine installation requirements and specific installation restrictions of the heater relative to propane storage tanks and filling equipment. Installation must meet the requirements for the Standard for the Storage and Handling of Liquid Petroleum Gases. Consult local codes and fire protection authorities about specific installation restrictions.

Locate the heater in an open, unroofed area and on a level surface that is protected from drainage or run-off. Install the heater in an area where leaves or other debris will not collect on or around the heater.

It is recommended that a non-combustible base be a platform under the heater, not less than 100 millimeters (mm) thick. **However, the heater is approved to be installed on a combustible surface.** To avoid damage to the electronic components in the heater, take care to prevent prolonged exposure to driving sources of water (such as lawn sprinklers, heavy roof runoff, hoses, etc.). Avoid operation in persistent, extreme, moist or salty environments. In extreme weather, shut down the heater and disconnect the power to it until the weather has moderated. In areas subject to hurricanes or very high winds, purchase the Bolt Down Bracket Kit, P/N 476004, see Figure 18.

**Note 1: DO NOT locate the heater where it is exposed to a prevailing wind. Note 2: Be sure the heater is level.**

HEATER BASE FOR USE ON NON-COMBUSTIBLE  
OR COMBUSTIBLE SURFACE

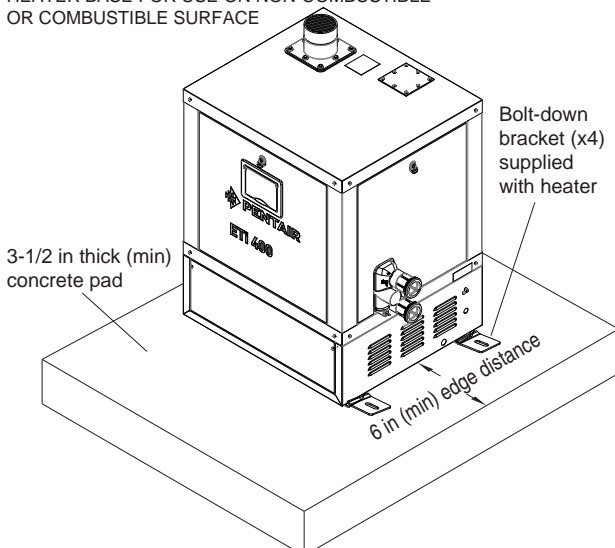

Figure 17.

For hurricane mounting bolts  
and clamps, purchase  
Bolt Down Kit P/N 476004

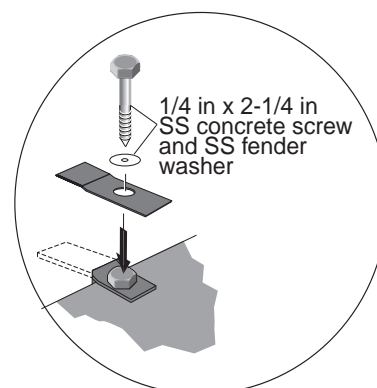

Figure 18.



## OUTDOOR HEATER INSTALLATION (CONTINUED)

### HEATER CLEARANCES – OUTDOOR

#### IMPORTANT!

- In an outdoor installation it is important to ensure water is diverted from overhanging eaves with a proper gutter/drainage system. **CAUTION!** If the heater is installed directly under a roof overhang, install a 90° street elbow onto the vent terminal. Install a 2 ft (61 cm) pipe section onto the elbow. Install the vent cap onto the end of the pipe. Direct the vent cap away from the house or building, (see page 23).
- The heater must be set on a level foundation for proper drainage.
- This unit shall not be operated outdoors at temperatures below 32° F (0° C).

If the heater is located under a roof or deck overhang, there must be at least three (3) feet (1 m) of clearance between the bottom of the overhang and the top of the heater exhaust vent, see Figure 19. If the heater is under a roof or deck overhang, the space around the heater must be open on three sides. **DO NOT** install the heater under any deck.

For minimum exhaust vent clearances for building openings, see Figure 24 on page 32.

In Canada, the heater must be installed with the top of the vent at least 10 ft (3 m) below, or to either side of, any opening into a building.

Orient the heater for convenient access to the water connections and the gas and electrical connections.

*Note: Check local building codes for installing the heater from any property line set back requirements (see Figure 16 on page 23 for installation illustration).*

#### **CAUTION**

**If installing the heater next to or near an air conditioning unit, heat pump or another gas pool heater, allow a minimum of 36 in. (91.4 cm) between the unit and the heater.**

Note: (\*) See Table 4  
(page 28) Category IV  
Requirements

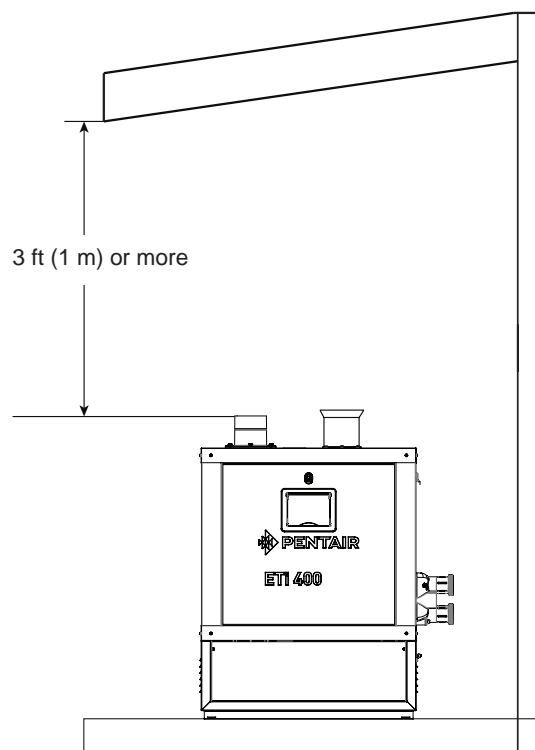

Figure 19.

## INDOOR VENTING — General Requirements

**The heater must be installed as a Category IV appliance.**

### ***Vented Appliance (Category IV) – Vertical or Horizontal***

An appliance that operates with a *positive* vent static pressure and with a vent gas temperature that allows excessive condensate production in the vent, see Figure 21 (page 28) and Figure 24, page 36.

If you are considering connecting this heater to a pre-existing vent system, make sure that the vent system meets the appropriate venting requirements as given in this manual on pages 33. If not, replace the vent system. **DO NOT** use a draft hood with this heater.

The heater operates with a positive vent static pressure and with a vent gas temperature less than 170° F (77° C). The total length of the horizontal run must not exceed the length that is listed in Table 3 on page 28.

## HEATER CLEARANCES — General Requirements

### ***INDOOR INSTALLATION OR OUTDOOR SHELTER (US AND CANADA)***

The following clearances must be maintained from combustible surfaces:

- TOP..... 6 in (15 cm)**
- EXHAUST SIDE ..... 6 in (15 cm)**
- HEADER SIDE ..... 6 in (15 cm)**
- DOOR PANELS (\*) ..... 6 in (15 cm)**

**NOTE:** (\*) For service access it is advisable to allow for sufficient clearance on at least one door panel. The heater is design certified by CSA International for installation on combustible flooring. For installation on carpeting, the heater must be mounted on a metal or wood panel that extends at least 3 in (10 cm) beyond the base of the heater. If the heater is installed in a closet or alcove, the entire floor shall be covered by the panel. For an outdoor shelter installation, the exhaust must discharge into a vent pipe. Orient the heater so that the vent pipe does not interfere with adjustment of the operator control panel.

**180° Control Panel and Plumbing Orientation:** The control panel board can be installed 180 degrees on either side of the heater, allowing for left or right side plumbing orientation for easy access.

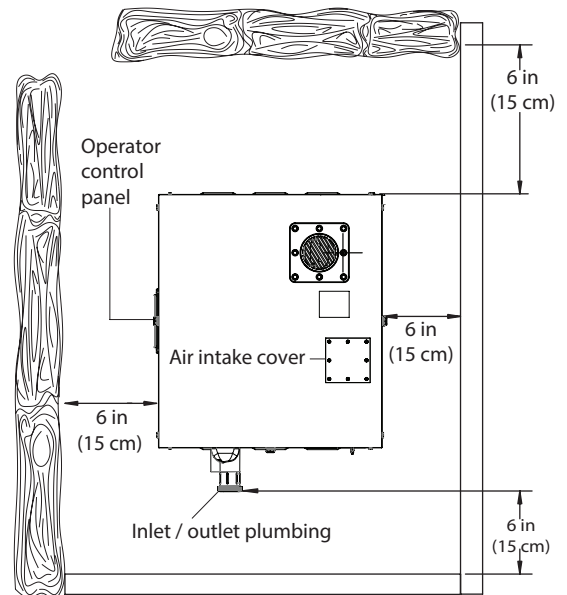

Figure 20.

## DIRECT AIR INTAKE COVER

The heater is supplied from the factory with a cover on the top panel for outdoor installation (see Figure 20). Remove the outside air intake cover for outdoor shelter installation or Indoor Installation.

## COMBUSTION AIR SUPPLY

For indoor installation, the heater location must provide sufficient air supply for proper combustion and ventilation of the surrounding area, see Table 3 below.

The minimum requirements for the air supply specify that the room in which a heater is installed should be provided with two permanent air supply openings; one within 12 inches (30 cm) of the ceiling, the other within 12 in (30 cm) of the floor for combustion air, in accordance with the latest edition of ANSI Z223.1, or the National Fuel Gas code, the CSA B149.1, Natural Gas and Propane Installation Codes, as applicable, and any local codes that may apply. These openings shall directly, or through duct, connect to outdoor air.

### Air Supply Requirements Guide for the ETi™ 400 Heater

Minimum Net Free Open Area for Each Opening* (Square Inches / Square Centimeters)				
Model	All Air From Inside Building		All Air From Outside Building	
	Combustion	Vent	Combustion	Vent
ETi 400	400 in <sup>2</sup> 2580 cm <sup>2</sup>	400 in <sup>2</sup> 2580 cm <sup>2</sup>	100 in <sup>2</sup> 645 cm <sup>2</sup>	100 in <sup>2</sup> 645 cm <sup>2</sup>

**NOTE \***: Vent must be at least 2.4 m (8 ft) away from nearest vertical surface. Vents extending 1.5 m (5 ft) or more above the roof must be braced or guyed. Consult your local code officials for detailed information.

**Table 3.** Note (\*) Area indicated is for one of two openings; one at floor level and one at the ceiling.

### CAUTION

Chemicals should not be stored near the heater installation. Combustion air can be contaminated by corrosive chemical fumes which can void the warranty.

**Note:** For indoor installations where combustion air might be insufficient, see **Direct Air Intake Duct with 4 in PVC Pipe (Indoor Installation) on page 28 and 29.**

### Direct Air Intake Duct with 4-inch PVC Pipe (Indoor Installation)

For indoor heater installations, the heater is tested for a direct air intake duct using 4 in PVC pipe. If outside air is drawn through 4 in PVC duct directly into the heater, vent pipe can be installed in accordance with the following requirements, see Table 4 below.

The air intake opening MUST be installed at least 1 ft. above the roof line or normal snow levels for free air flow. The Category IV exhaust vent termination cap must have at least 3 ft. (1 m) minimum vertical clearance from air intake duct, see Figure 21.

#### Combustion 4 in (10 cm) PVC Pipe Inlet Air Intake Duct Requirements\*

* Combustion Air Intake 4 in. (10 cm) Pipe (Vertical or Horizontal)	
No. of 90° Elbows	Maximum Length in Feet (M)
0	120 ft. (30.5 M)
1	108 ft. (27.4 M)
2	96 ft. (24.4 M)
3	84 ft. (21.3 M)
4	72 ft. (18.3 M)

**CAUTION**

Do **NOT** combine exhaust vent pipes to a common exhaust vent in multiple unit installations. Run separate vent pipes.

Table 4.

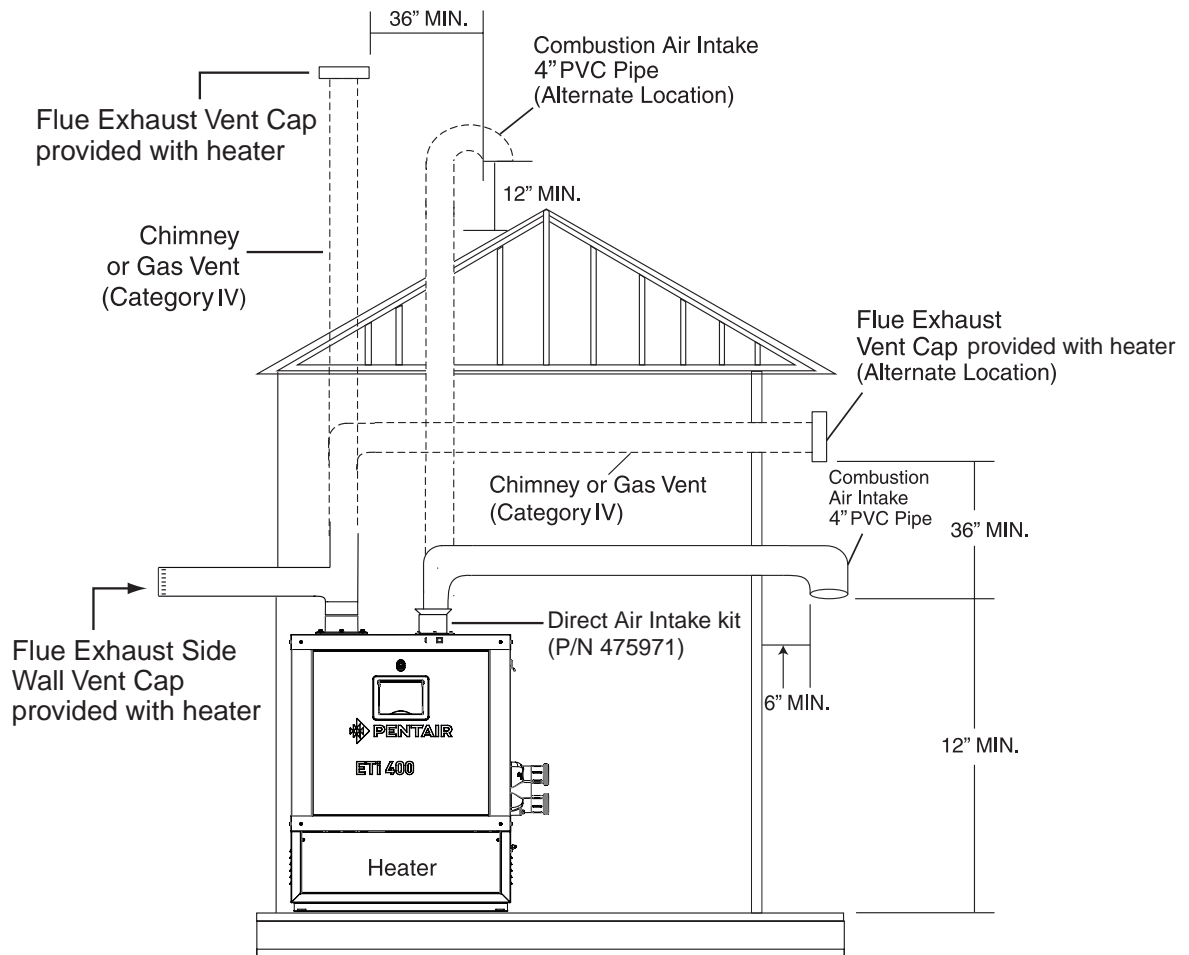

Figure 21.

## DIRECT AIR INTAKE KIT (P/N 475971) INSTALLATION

**IMPORTANT:** For indoor heater installations with Direct Air Intake duct using 4 in PVC duct it is required to order and install the Direct Air Intake Kit (P/N 475971).

To install the Direct Air Intake Kit (see Figure 22), the steps are as follows:

1. Remove the side panel from the heater to access the Vent Terminal (see illustration below). Using a flat-blade screwdriver, insert press and turn the screwdriver to unlock the panel.
2. Remove the Air Intake Vent cover from the top of the heater.
3. Insert the spigot part of the street wye up through the air intake hole in the top panel.
4. Insert the 45° elbow into the 3 in pipe section of the assembly that has the street wye.
5. Adjust the 45° elbow to align each 3 in pipe section with the air orifice.
6. Push the air intake assembly into the air orifices. Note: Be sure the top part of the elbow is concentric to the air intake hole in the top panel (see Figure 23).
7. Place the 3 x 4 in reducer to the street wye plate of the elbow and secure it with the 3 sheet metal retaining screws.

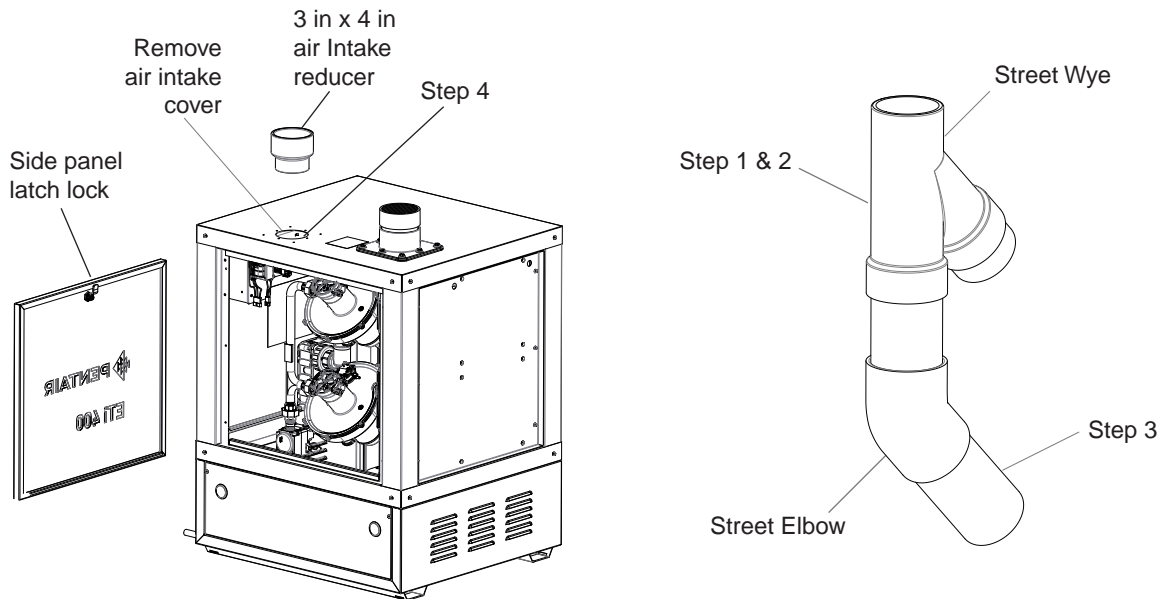

Figure 22.

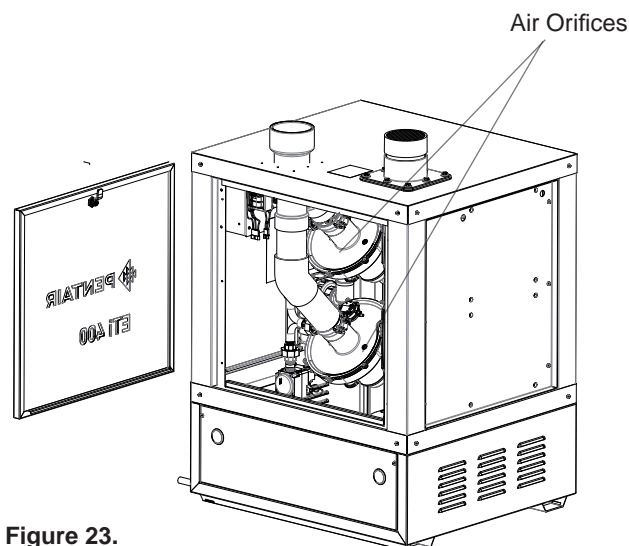

Figure 23.

## **COMBUSTION AIR SUPPLY (CONTINUED)**

### **NOTE**

Each 90-degree elbow reduces the maximum horizontal PVC air intake duct run by 12 feet and each 45-degree elbow in the PVC air intake duct run reduces the maximum run by 6 feet. See the Table 5 on page 28 for the maximum lengths using 90-degree elbows.

### **⚠ CAUTION**

Chemicals should not be stored near the heater installation. Combustion air can be contaminated by corrosive chemical fumes which can void the warranty.

### **Corrosive Vapors and Possible Causes**

<b>Area</b>	<b>Likely Contaminants</b>
Chlorinated swimming pools and spas	Pool or spa cleaning chemicals. Acids, such as hydrochloric or muriatic acid.
New construction and remodeling areas	Glues and cements, construction adhesives, paints, varnishes, and paint and varnish strippers. Waxes and cleaners containing calcium or sodium chloride.
Beauty parlors	Permanent wave solutions, bleaches, aerosol cans containing chlorocarbons or fluorocarbons.
Refrigeration plants or various industrial finishing and processing plants	Refrigerants, acids, glues and cements, construction adhesives.
Dry cleaning and laundry areas	Bleaches, detergents, or laundry soaps containing chlorine. Waxes and cleaners containing chlorine, calcium or sodium chloride.

Table 5.

## **HORIZONTAL OR VERTICAL VENTING (CATEGORY IV) - POSITIVE PRESSURE**

**(See Figure 28, page 32 and Figure 26, page 34)**

Vent the heater either horizontally or vertically using the 4 in Vent Adapter that is provided with the heater. Install the vent pipe in accordance with local codes and the provisions of the National Fuel Gas Code, ANSI Z223.1 (U.S.), or the standards CSA B149.1, Natural Gas and Propane Installation Codes (Canada), and the vent manufacturer's instructions. Do not use a draft hood with this heater. Install the vent according to the vent manufacturer's detailed instructions. **Note:** Maintain clearance between the vent pipe and combustible surfaces according to the vent manufacturer's instructions and code requirements. Do not place any insulating materials around the vent or inside the required clear air space surrounding the vent. See Table 6 for maximum permissible vent lengths.

### **NOTE**

**Each 90° elbow reduces the maximum horizontal vent run by 12 ft and each 45-degree elbow in the vent run reduces the maximum vent run by 6 ft. See the Table 6 below for the maximum vent lengths using 90° elbows.**

## **The ETi™ 400 heater is a Category IV appliance**

The ETi 400 heater requires a 4 in special gas approved *Category IV* vent pipe and is a forced-draft pool and spa heater which uses positive pressure to push flue gases through the vent pipe to the outside. **Flue gases under positive pressure may escape into the dwelling with any cracks or loose joints in the vent pipe, or improper vent installation.** The vent pipe must be of a sealed-seam construction, such as those listed for use with *Category IV Appliances*. Vent pipe construction will be of UL 1738 approved non-corrosive material, such as non-metallic PVC schedule 40 per ASTM D2665, CPVC schedule F441 or stainless steel such as AL 29-4C per UL 1738 in USA. In Canada must comply with ULC-5636 code requirements. The 4-in exhaust socket is CPVC. A condensate trap is required.

**Note: To solvent weld the PVC vent pipe to the CPVC exhaust socket use an approved industry standard primer and cement solvent specifically intended and marketed for PVC/CPVC joints, consult the adhesive manufacturer for details.**

The use of *Approved* thimbles, roof jacks and/or side vent terminals are required; and the proper clearances to combustible materials must be maintained in accordance with type of vent pipe employed—in the absence of a clearance recommendation by the vent pipe manufacturer, the requirements of the Uniform Mechanical Code should be met. **The ventilation air requirements for the heater are shown on page 32 & 34.** It is recommended that use of a condensate trap in the vent run close to the heater may be necessary in certain installations such as cold climates. Horizontal vents 4 in (25.4 mm) or less in length do not require a condensate tee. The heater is suitable for through-the-wall venting.

<b>4 in. Special Gas Vent (*)</b> (Vertical or Horizontal)	
No. of 90° Elbows	Maximum Length in Feet (M)
0	120 ft. (30.5 M)
1	108 ft. (27.4 M)
2	96 ft. (24.4 M)
3	84 ft. (21.3 M)
4	72 ft. (18.3 M)

**(\*)** Minimum vent length is 1 ft (.34M), or in accordance with vent manufacturer's instruction, and local and national codes. Horizontal vents 3 ft (1M) or less in length do not require a condensate tee, but must slope down toward the heater at 1/4 in to the foot (2 cm / m) to allow condensate to drain through the neutralizer cartridge.

Table 6.

**DIRECT VENT REQUIREMENTS**

1. Install vent pipe so that it can expand and contract freely as the temperature changes. Support the vent pipe according to applicable codes and vent manufacturer’s instructions. Pipe support must allow the vent pipe free movement out and back, from side to side, or up and down as necessary, without putting a strain on the heater or vent body. It is recommended to slope the horizontal pipe runs up from the heater at least 1/4" per foot (2 cm/M). Install **Approved** condensate drains at low points where condensate might collect. Plumb condensate drains to a drain through hard piping or high-temperature tubing such as silicone rubber or EPDM rubber – do not use vinyl or other low temperature tubing. Follow drain manufacturer’s installation instructions.
2. Use an *Approved* firestop for floor and ceiling penetrations. Use an *Approved* thimble for wall penetrations. Use an *Approved* roof flashing, roof jack, or roof thimble for all roof penetrations. Do not fill the space around the vent (that is, the clear air space in the thimble or firestop) with insulation. The roof opening must be located so that the vent is vertical.
3. **Vent Termination:** Vertical (See Figure 24 below and Figure 26 on page 34), for height of vent termination above the roof. Use an *Approved* vent terminal specified by local and national codes and your manufacturer’s instructions. A roof termination must be vertical. In Canada, the Vent Cap location shall have a minimum clearance of 4 feet (1.2M) horizontally from electric meters, gas meters, regulators, and relief openings.
4. Make sure entire installation is sealed according to approved standards.

**⚠WARNING**

**Risk of carbon monoxide poisoning if adapter is improperly attached.** Mechanical connections (such as screws) can cause cracking and leaks in the adapter. Do **NOT** drill holes or use screws to connect the appliance adapter to the heater vent body. Attach with manufacturer’s specified adhesive.

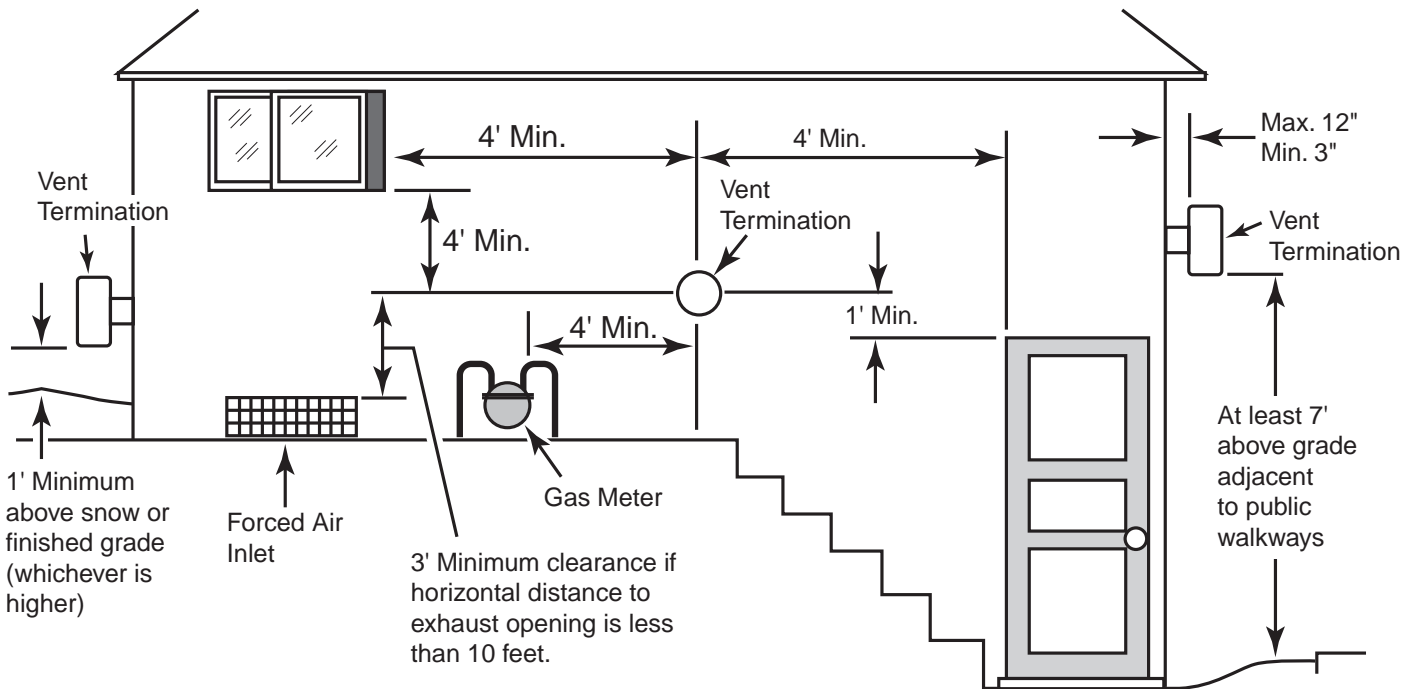

Figure 24.



## 5. Vent Termination - Horizontal

The terminal must be located (U.S. – See Figure 24 on page 32):

- at least 3" and at most 12" out from the wall (see Figure 25 on page 33), following the vent manufacturer's instructions
- at least 12" above finished grade or the normally expected snow accumulation level, whichever is higher
- at least 4 feet below or horizontally from, or 1 foot above, any doors or windows or gravity air inlet to a building
- at least 3 feet above any forced air inlet located within 10 ft.
- at least 4 feet horizontally from electric meters, gas meters, regulators and relief equipment
- at least 7 feet above grade adjacent to walkways or similar traffic areas

The terminal must be located (Canada – See Figure 24 on page 32):

- at least 10 feet (3.3M) from any opening into a building
- at least 12" (.3M) above finished grade or the normally expected snow accumulation level, whichever is higher
- at least 4 feet (1.2M) horizontally from electric meters, gas meters, regulators and relief equipment
- at least 7 feet (2.1M) above grade adjacent to walkways or similar traffic areas

Allow at least three feet (1M) vertical clearance over vent termination when terminating under an overhang.

Avoid corners or alcoves where snow or wind could have an effect. Exhaust may affect shrubbery and some building materials. Keep shrubbery away from termination. To prevent staining or deterioration, sealing or shielding exposed surfaces may be required.

### WARNING

**Fire Hazard.** Do not run the heater vent into a common vent with any other appliance. Do not run the Special Gas Vent into, through, or within any active vent such as a factory built or masonry chimney.

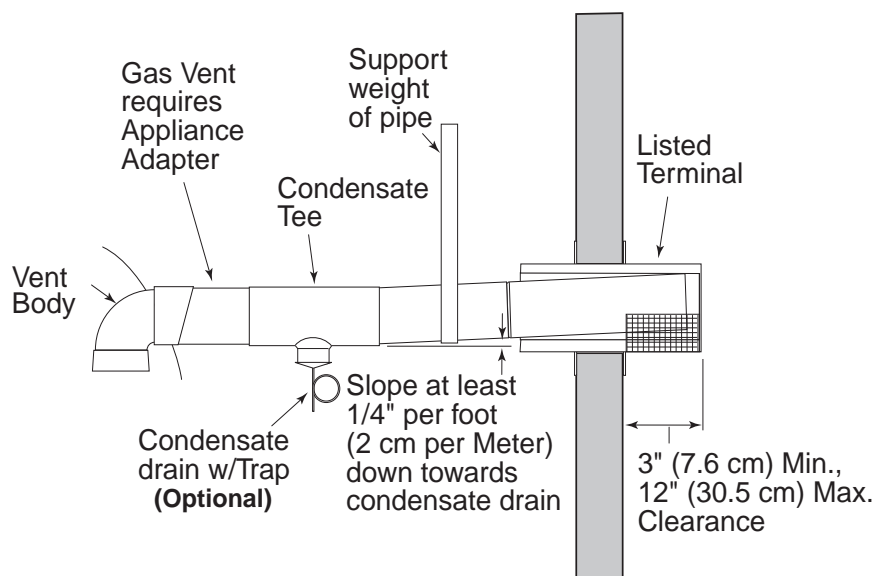

Figure 25.

## Direct Vent - Horizontal Through-the-Wall

### Termination

The flue direct vent cap **MUST** be mounted on the exterior of the building. The direct vent cap cannot be installed in a well or below grade. The direct vent cap must be installed at least 1' (0.3 m) above ground level and above normal snow levels, see Figure 24, page 32. The direct vent cap **MUST NOT** be installed with any combustion air inlet directly above a direct vent cap. This vertical spacing would allow the flue products from the direct vent cap to be pulled into the combustion air intake installed above.

This type of installation can cause non-warrantable problems with components and poor operation of the heater due to the recirculation of flue products. Multiple direct vent caps should be installed in the same horizontal plane with a 4' (1.22 m) clearance from the side of one vent cap to the side of the adjacent vent cap(s).

Care must be taken during assembly that all joints are sealed properly and are airtight. The vent must be drained to prevent the potential accumulation of condensate in the vent pipes.

It is recommended that the intake vent (see Figure 26) be insulated in colder climates.

Combustion air supplied from outdoors must be free of particulate and chemical contaminants. To avoid a blocked flue condition, keep the vent cap clear of snow, ice, leaves, debris, etc.

### WARNING

**No substitutions of flue pipe or vent cap material are allowed. Such substitutions would jeopardize the safety and health of inhabitants. Use CPVC schedule 40 per ASTM D2665, CPVC schedule F441 or stainless steel, such as AL 29-4C per UL 1738 in USA. Canada must comply with ULC-S636 code requirements.**

**Venting:** Vent systems for Category IV appliances that terminate through an outside wall of a building and discharge flue gases perpendicular to the adjacent wall, must be located not less than 10 ft horizontally from an operable opening in the adjacent building. **Exception:** This does not apply to vent terminals that are 2 ft or more above 25 ft or more below the operable openings. Through the wall vents for Category IV must not terminate over public walkways or over an area where condensate or vapour could create nuisance or hazard or could be detrimental to the operation of regulators, relief valves, or other equipment.

Note: (\*) See Table 4  
(page 28) Category IV  
Requirements

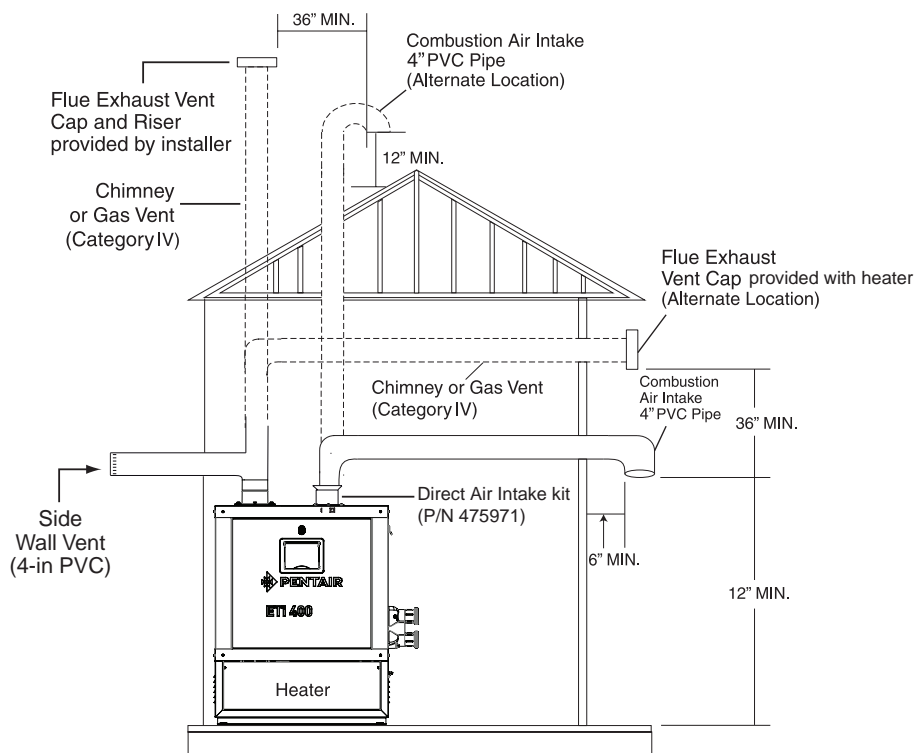

Figure 26.

## GARAGE OR UTILITY ROOM INSTALLATION

### **⚠ WARNING**

**Risk of fire and explosion if installed at floor level in an automotive garage or near gasoline or flammable liquid storage.** Gasoline fumes are heavier than air and will settle to floor level in closed spaces. Gasoline fumes and spilled gasoline or other volatile liquids (such as some paints and varnishes) will travel across the floor and can be ignited by a gas appliance.

In any utility room or residential garage installation, install the heater with the base at least 18 inches (.5M) above the floor, see Figure 27. In a garage, install a rail or wall to protect the heater from physical damage by a moving vehicle.

**NOTICE: A Propane (LPG) fired heater must not be installed in a garage in Massachusetts, by order of the Massachusetts State Fire Marshal. For more information, call the Massachusetts State Fire Marshal's office.**

### **VENT INSTALLATION – INDOOR INSTALLATION (U.S. AND CANADA)**

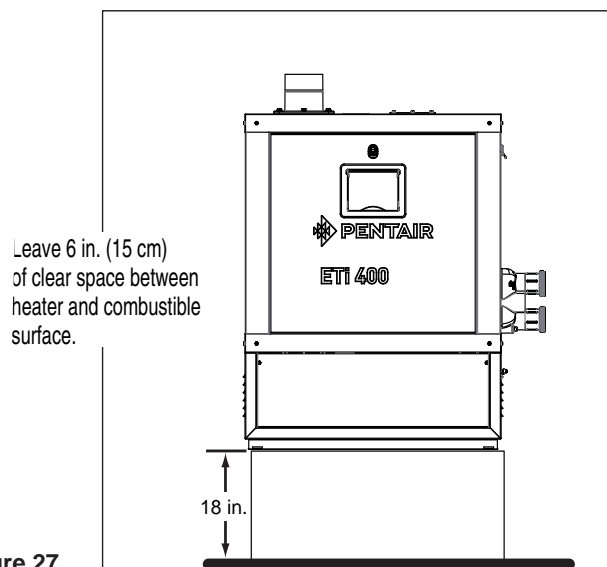

Figure 27.

### **FINAL INSTALLATION CHECK**

*After heater installation, check and verify the following:*

- Check that horizontal vent pipe runs slope uniformly at least 1/4" per foot (2 cm per meter) upward from the heater to the vent terminal. No sags, no dips, no high or low spots.
- Check that vent is supported at elbows, tees, and horizontal and vertical runs according to manufacturer's instructions and code requirements.
- Check that vent supports and wall and ceiling penetrations allow free movements up, down, and sideways without causing any strains on the heater or vent body.
- Check for at least six inch (15 cm) free air clearance between the heater vent pipe and combustible materials.
- There should be at least 30 in of clearance in front of the heater to provide adequate service space and access to the operator control panel, electrical controls and other operating components.
- Check that all joints are completely together and sealed.
- In Florida, building codes require that the heater be anchored to the equipment pad or platform to withstand high wind pressures created during hurricanes. A hold down bracket kit is designed to hold the unit to the equipment pad in high wind conditions. Installation of the anchor clamps are recommended in all installations and are required in Florida, (See Florida Building Code 301.13). For hurricane mounting bolts and clamps, purchase Bolt Down Kit P/N 476004.

## CONDENSATION MANAGEMENT

The ETi™ 400 Heater is a condensing appliance. The flue gases will produce condensate while in operation and must be drained correctly. **Note: The condensate pH level is between 3.1 and 4.2, Pentair recommends to neutralize the condensate to avoid potential damage over time to the drainage system, and to comply with local water authorities where applicable.** To neutralize the condensate, use an optional Condensate Neutralizer Kit P/N 475612 or similar. The condensate drain must be installed so as to prevent accumulation of condensate. When a condensate pump is not used, the tubing must continuously slope downward toward the drain with no spiraling.

**⚠ CAUTION!** pH levels of 5.0 and below may harm some floor drains and/or pipes, particularly those that are metal. Ensure that the drain, drainpipe, and anything that will come in contact with the condensate can withstand the acidity. Damage caused by failure to install a neutralizer kit or to adequately treat condensate will not be the manufacturer's responsibility.

**⚠ WARNING!** DO NOT allow the exhaust flue gases to vent through the neutralizer. All condensate drains MUST have a trap to prevent flue gas leakage. Flue gas leakage can cause personal injury or death from carbon monoxide. Check with local authorities for regulations regarding discharge of condensate to the drain sewer system.

### Condensate Maintenance

**Annual condensate assembly inspection:** Inspect the inside tubing top for any dirt or particles that could collect and clog the condensate neutralizer cartridge. **DO NOT route the condensate outside tubing through any area that is exposed to freezing temperatures.**

### Condensate Neutralizer Cartridge Drain/Tubing Installation (FOR INDOOR OR OUTDOOR HEATER INSTALLATION)

To install the external condensate neutralizer cartridge drain/tubing:

1. Connect the PVC socket adaptors to the neutralizer. **DO NOT OVERTIGHTEN.**
2. Connect the inside tubing to the inlet of the neutralizer cartridge.
3. **Indoor Heater Installation (Fig. 24a):** Mount the neutralizer cartridge on the floor near the side of the heater. **Outdoor Heater Installation (Fig. 24b):** Using the provided brackets, secure the neutralizer cartridge onto the heater base.
4. Connect the outside tubing to the outlet of the neutralizer cartridge. Be sure the tubing is at its highest point at the cartridge outlet.
5. Route the outside tubing to a drain or to a pump. Maintain a pitch of  $\frac{1}{4}$  in per foot downward from the cartridge outlet.
6. Fill the condensate trap with water until flow is established through the neutralizer. **Note: Observe the neutralizer during the heater operation to ensure unrestricted flow.**

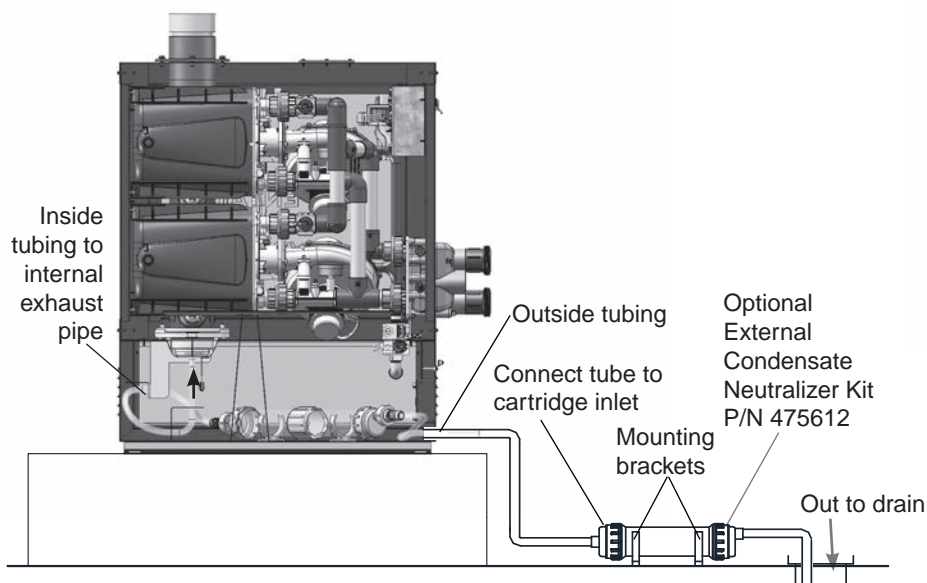

Figure 24a. External Neutralizer Cartridge for indoor heater Installation

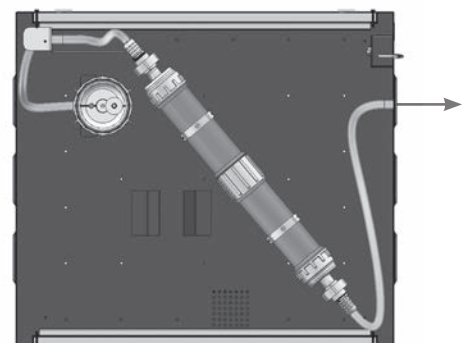

Figure 24b. Internal Neutralizer Cartridge installed on base of heater for outdoor heater Installation

## ELECTRICAL CONNECTIONS

*Electrical Rating: 60 Hz 120 / 240 Volts AC, single phase*

Enclose the incoming AC power line to the heater, in an approved flexible conduit connected directly to the junction box on the inside of the lower right side of the heater (see Figure 11 on page 18). The Line Voltage field wiring is 14 gauge, with a circuit capacity of 15 Amps.

The Heater is factory wired for 240 VAC. See page 38 for 240 VAC and 120 VAC wiring.

### CAUTION

This heater is designed to operate at 120 or 240 VAC. It is not recommended to be connected to OR operate on a 208 VAC.

### CAUTION

The heater ships from the Factory with the 240V plug installed. Installing the 120V plug and then connecting the heater to 240V line current will immediately damage the transformer, control board, and will void the warranty. If you install the 240V plug and connect the heater to 120 volts line current, the heater will not operate.

### CAUTION

If, while there is line voltage connected to the heater, you touch either line voltage terminal with any 24VAC wire that is connected to the control board (including the Fireman's Switch jumper), you will immediately destroy the control board and void the warranty.

**Please read the information under IMPORTANT! READ ME FIRST! on pages 42 and 45 before proceeding.**

- All wiring must be in accordance with all applicable codes.
- The heater, when installed, must be electrically grounded and bonded in accordance with local codes or, in the absence of local codes, with the National Electrical Code or the Canadian Electrical Code (as applicable).
- Electrical power circuits to the pool heater must follow local codes and National Electrical Code or Canadian Electrical Code (as applicable).
- All wiring between the heater and devices not attached to it, or between separate devices which are installed in the field, must be **Type T** wire rated for 35°C rise.
- All line voltage wiring shall be enclosed in approved flexible conduit, and shall be securely attached to the field wiring box located in the lower right side of the water manifold panel (see Figure 11 on page 18). The conduit or cable connector at the field wiring box should contain an insulating bushing or its equivalent to prevent abrasion of the wires as they enter the box.
- **The filter pump should run continuously when the heater is on, and for at least 15 minutes after the heater turns off.** Any switches in the pump circuit (including circuit breakers) that can disconnect the pump must also disconnect the heater.

## Bonding

- A bonding lug is provided on the heater located on the upper side of the base by the plumbing side (see page 18). The heater along with the pool system equipment must be bonded together. Using solid copper conductor not smaller than 8 AWG to reduce voltage gradients in the pool area.

## ELECTRICAL CONNECTIONS (CONTINUED)

### 120 VAC Wiring

- Connect the BLUE PLUG (120 VAC) into the 12-pin plug located on the electrical panel, see Figure 30).
- Connect the L1 to the BLACK WIRE in the heater.
- Connect the NEUTRAL WIRE to the RED WIRE in the heater.
- Connect the GROUND WIRE to the GREEN WIRE in the heater.

### 240 VAC Wiring

- Connect the RED PLUG (240 VAC) into the 12-pin plug located on the electrical panel, see Figure 30).
- Connect the L1 to the BLACK WIRE in the heater and the other L2 to the RED WIRE at the heater.
- Connect the GROUND WIRE to the GREEN WIRE in the heater.

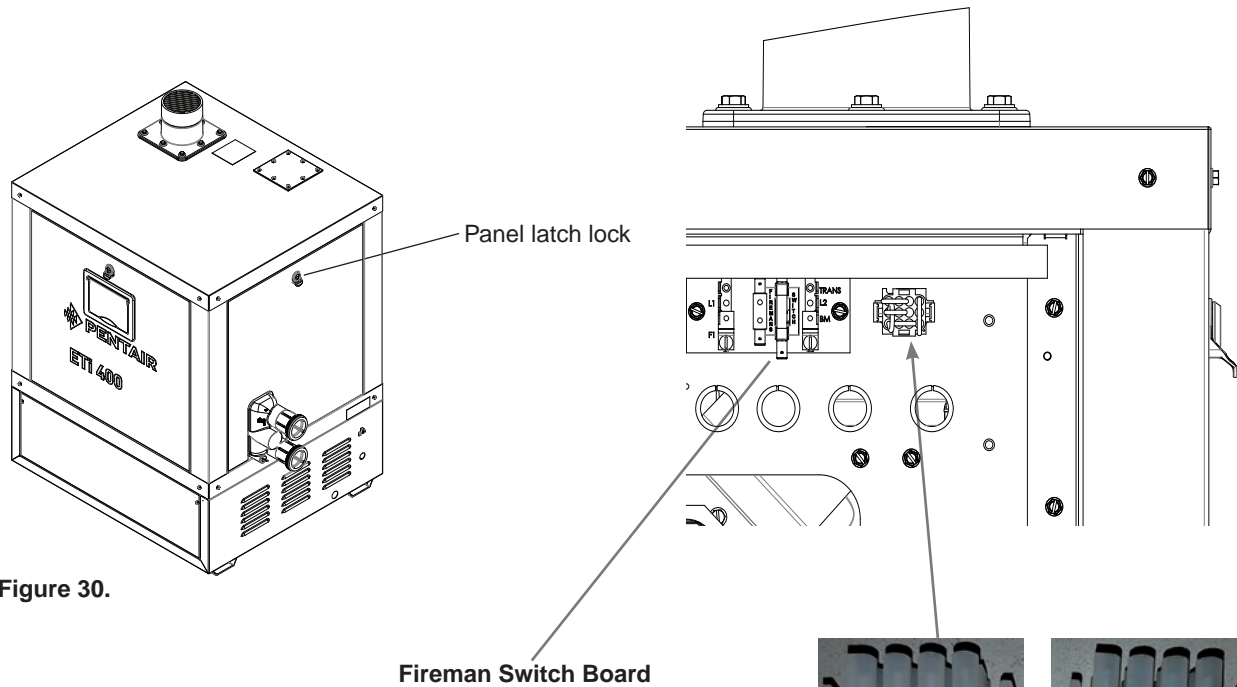

Figure 30.

**⚠ CAUTION!** The 120 VAC (Blue plug) voltage selector is NOT interchangeable with the MasterTemp® or StaRite® Heater voltage selector (Black plug)



120 VAC  
(BLUE)



220 VAC  
(RED)

## **ELECTRICAL CONNECTIONS (CONTINUED)**

### **REMOTE CONTROL CONNECTIONS**

1. **NOTE: Switch off power to heater at main circuit breaker panel.**
2. Remove the front side door panel, see Figure 30 on page 38.
3. Locate the **Fireman Switch jumper wire**; remove the wire. See Figure 31 below.
4. Connect the **Remote Control Dry Contact wires**. See Figure 31 below.

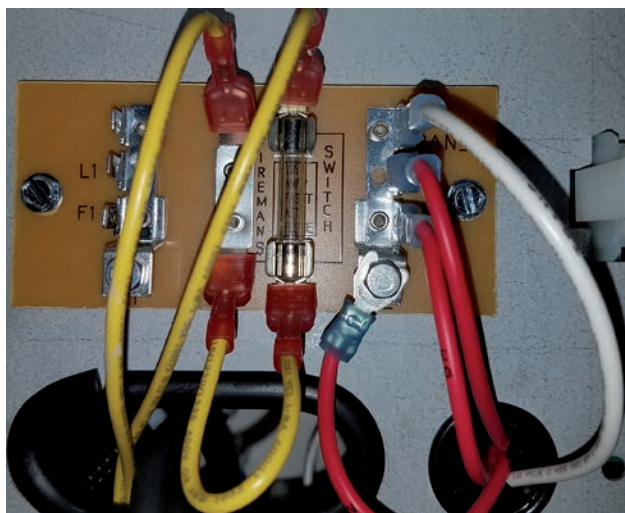

Figure 31.

#### **CONNECTION OF FIREMAN'S SWITCH OR REMOTE CONTACT YELLOW JUMPER WIRE**

4. **To connect a 2-Wire Control (such as IntelliTouch® or EasyTouch® Control System) or a timer:**
  - Remove the factory installed jumper from the Fireman's Switch terminals.
  - Connect wires between the Fireman's Switch terminals on the heater and the relay. Connect wires from the controller or timer to the Fireman's Switch. Controller, timer or relay should be sized to handle 24 VAC at 0.5 Amp (because it will be completing the 24 VAC control board circuit on the heater as shown in Figure 30 on page 38). **DO NOT** apply line voltage to the Fireman's Switch terminals. Use 18 gauge wire with a minimum 3/64-in (1.2 mm) thick insulation rated for a temperature rise of at least 105°C.
  - Knock-outs are provided to route the wires through the bottom of the control box and past the junction box.
5. Close front side door panel.

To control heaters that are operated in parallel, connect wiring at same locations on heater as 2-Wire. It is imperative that each control circuit is isolated from the other control circuits, to avoid that current will flow from one heater to another through the control circuits.

**NOTICE: The fuse for the Fireman's Switch is a 1.25 Amp 1¼ x ¼" fast blow fuse, which is commonly available.**

### **FIREMAN'S SWITCH**

#### **TIME CLOCK/FIREMAN'S SWITCH (See Figure 31 above):**

A time clock controlling the filter pump should be a dual switch low-voltage Fireman's Switch should be set to shut off the call for heat to the pool heater 15 to 20 minutes before shutting down the pool pump. Always use crimp type connectors when connecting two wires. To operate the heater with a time clock, connect the timer to the fireman's switch wiring connection, as shown in the illustration on right. **The fireman's switch connection is located at the Yellow jumper wire below the fuse.** The fireman's switch connection must be a dry contact and must not supply power to the heater. Powering the fireman's switch connection externally may damage the heater, and is not covered by warranty.

# HEATER CONNECTION WIRING DIAGRAM

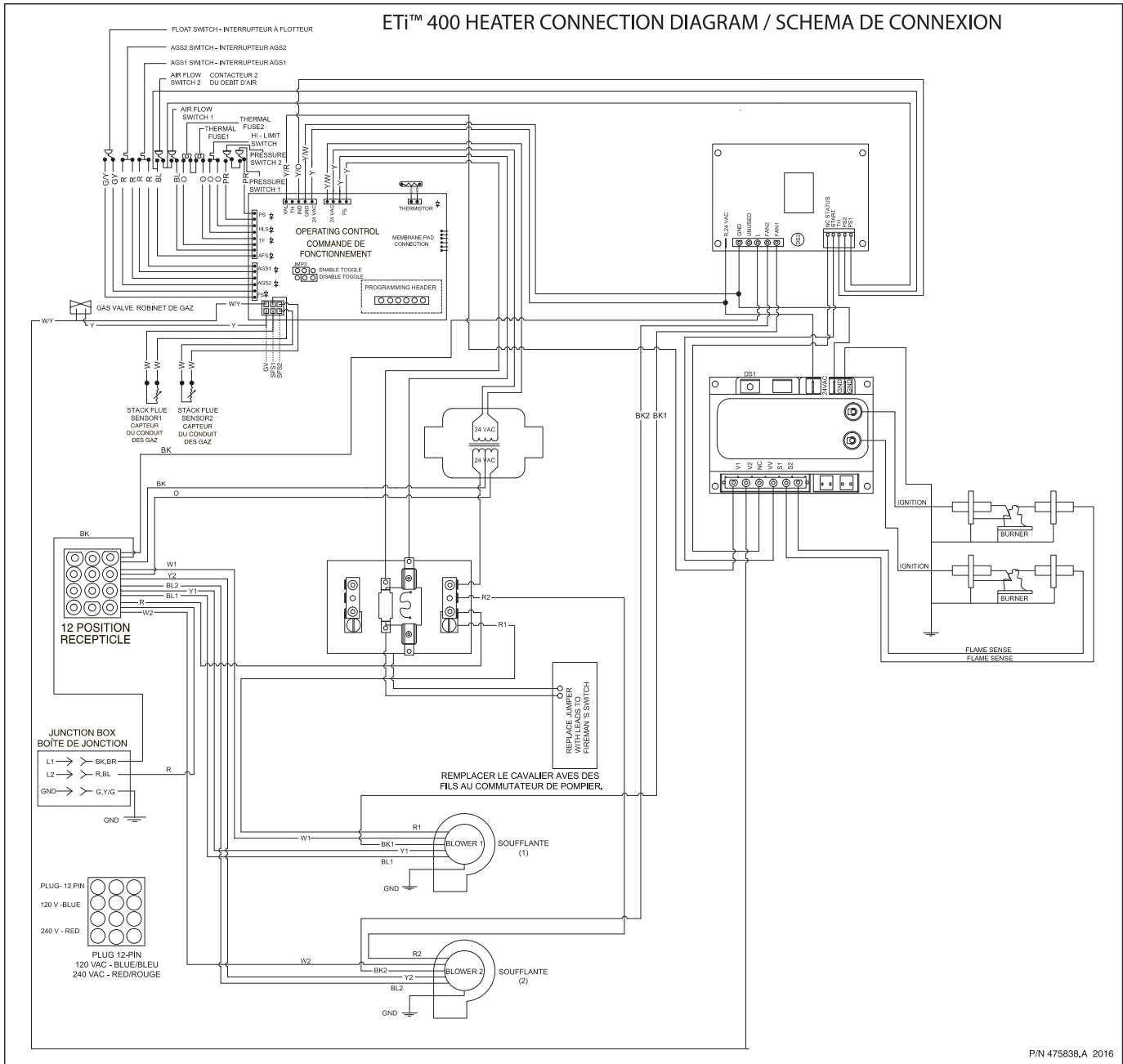
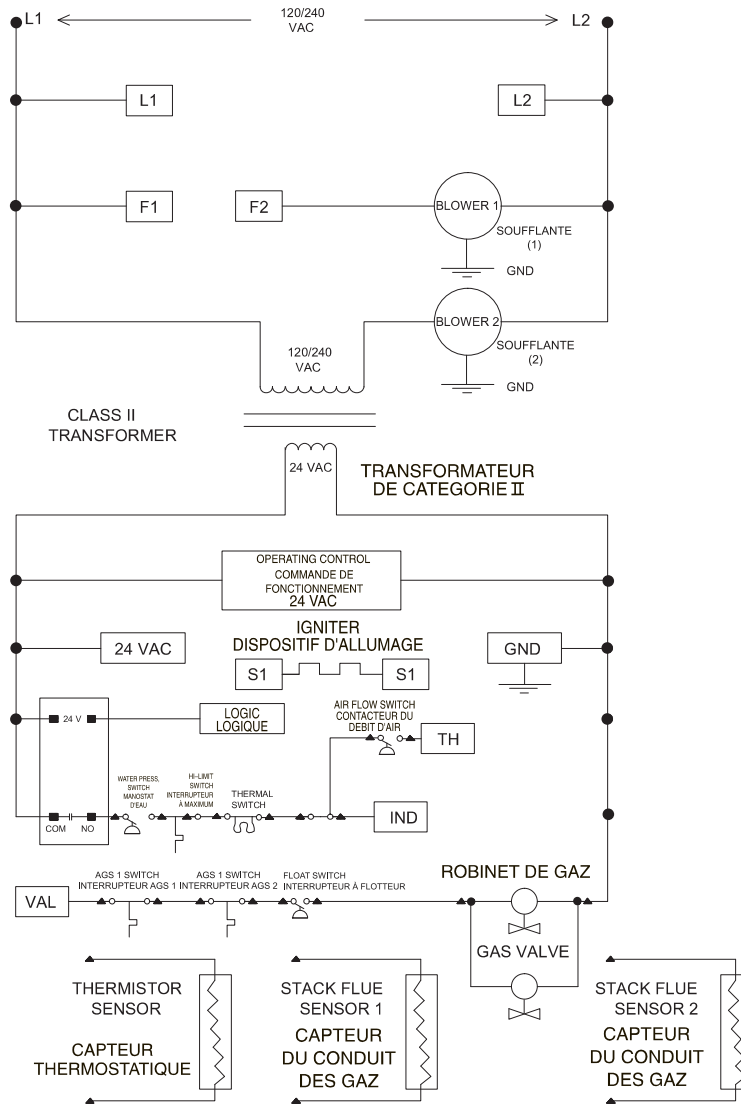

Figure 32.



# HEATER LADDER WIRING DIAGRAM

## LADDER DIAGRAM DIAGRAMME EN ESCALIER



NOTES:-

- 1) 

L1	L2	F1	F2	S1	24 VAC
S2	GND	IND	VAL	TH	

ARE CONNECTED ON THE IGNITION MODULE.

2) ▲ PIN AND SOCKET CONNECTOR.

3) IF ANY OF THE ORIGINAL WIRES ARE SUPPLIED WITH THE APPLIANCE MUST BE REPLACED, THEY MUST BE REPLACED WITH TYPE 105°C WIRE OR ITS EQUIVALENT.

NOTA:

- 1.) 

L1	L2	F1	F2	S1	24 VAC
S2	GND	IND	VAL	TH	

SONT BRANCHÉS SUR LE MODULE D'INFLAMMATION.

2.) ▲ CONNECTEUR À BROCHES ET À DOUILLES.

3.) SI UN DES FILS D'ORIGINE LIVRÉS AVEC CET APPAREIL DOIT ÊTRE REMPLACÉ, LE REMPLACER PAR UN FIL DE TYPE 105°C OU UN FIL ÉQUIVALENT.

Figure 33.

# Section 3: Troubleshooting

## Initial Troubleshooting

Only qualified, trained service technicians with appropriate test equipment should service the heater. Remember that all parts of the system affect heater operation. Before starting this troubleshooting procedure, make sure that the pump is running correctly, that there are no blockages in the system, that the valves are correctly set and that the time clock is correctly set and is running.

### IMPORTANT! READ ME FIRST!

**NOTICE:** Installing the **BLUE 120 volt** plug in the control box and then connecting the heater to a **240 volt line will destroy the transformer, control board, and ignition control module, and will void the warranty.** If you install the **RED 240 volt** plug and then connect the heater to a 120 volt line, the heater will not operate.

**READ THE FOLLOWING CAREFULLY:**

1. Check the line voltage to your heater. This heater will operate

on either 120 Volts AC or 240 Volts AC.

2. Remove the covers and check the 12-pin plug in the back of the control box. The plug must match the voltage in the heater circuit.
3. If the 12-pin plug is not plugged into the back of the control box, select the correct plug from the bag in the control box and plug it in. The **BLUE** plug is for **120 volts**, the **RED** plug is for **240 volts**.

## Start here for directions to specific Troubleshooting Chart

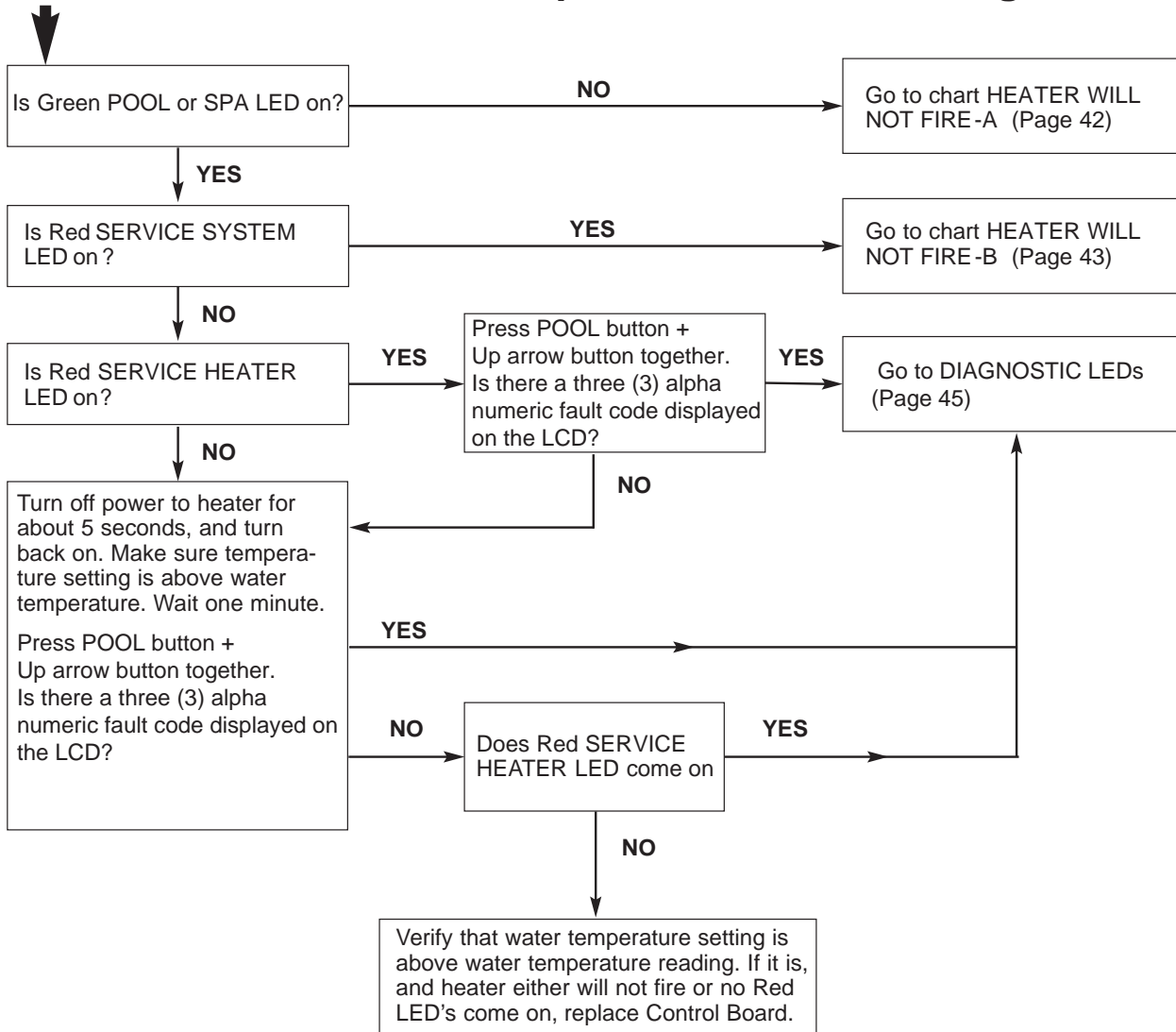

<p><b>⚠ WARNING</b> Hazardous voltage. Can shock, burn or kill. Disconnect power before servicing any components.</p>	<p><b>⚠ WARNING</b> Fire and Explosion hazard. Do not jumper switch terminals to remedy a failed safety switch.</p>
---	---

# Heater Will Not Fire - A

## Start

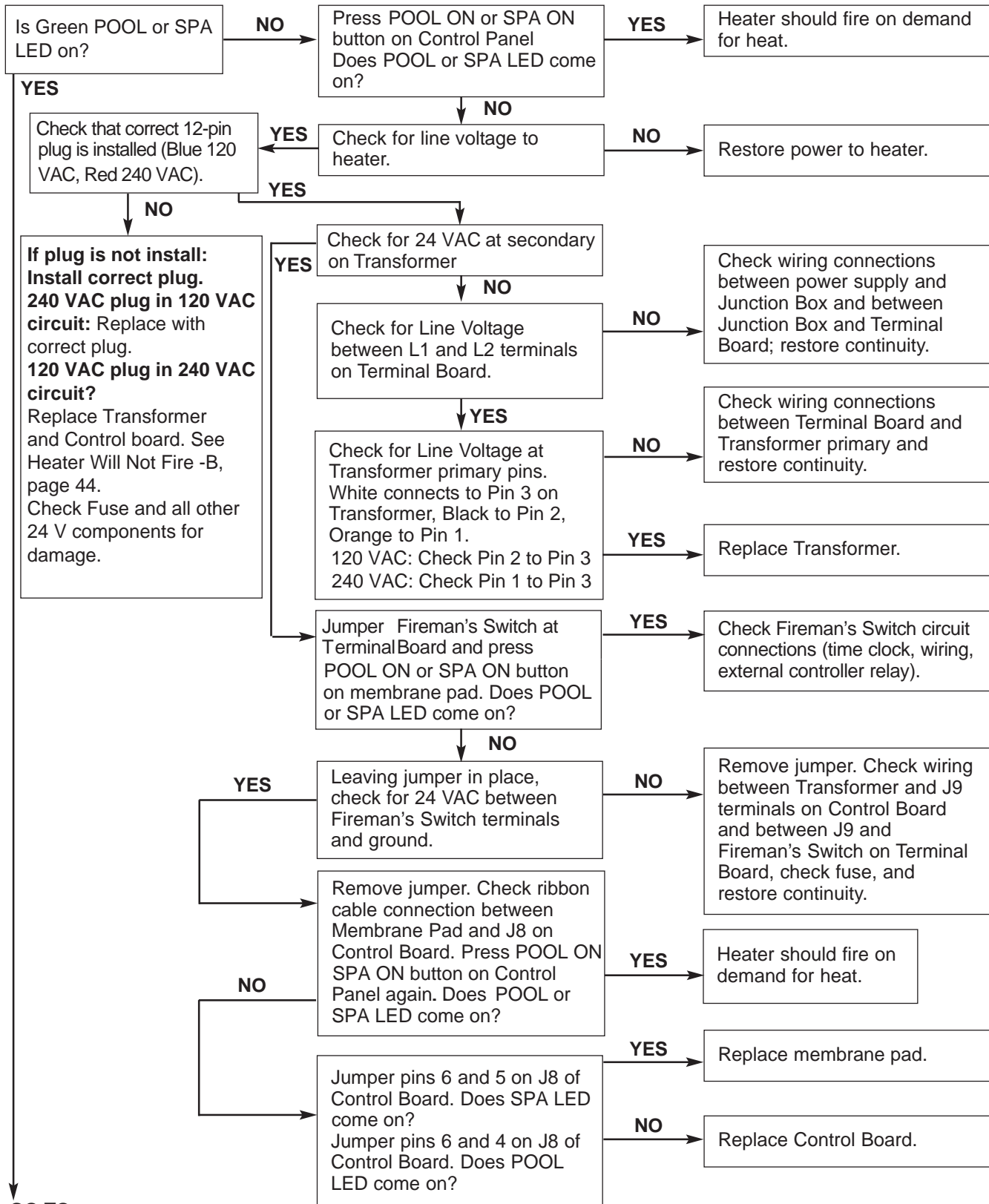

**GO TO  
HEATER WILL NOT FIRE - B  
Page 44**

# Heater Will Not Fire - B

## Start

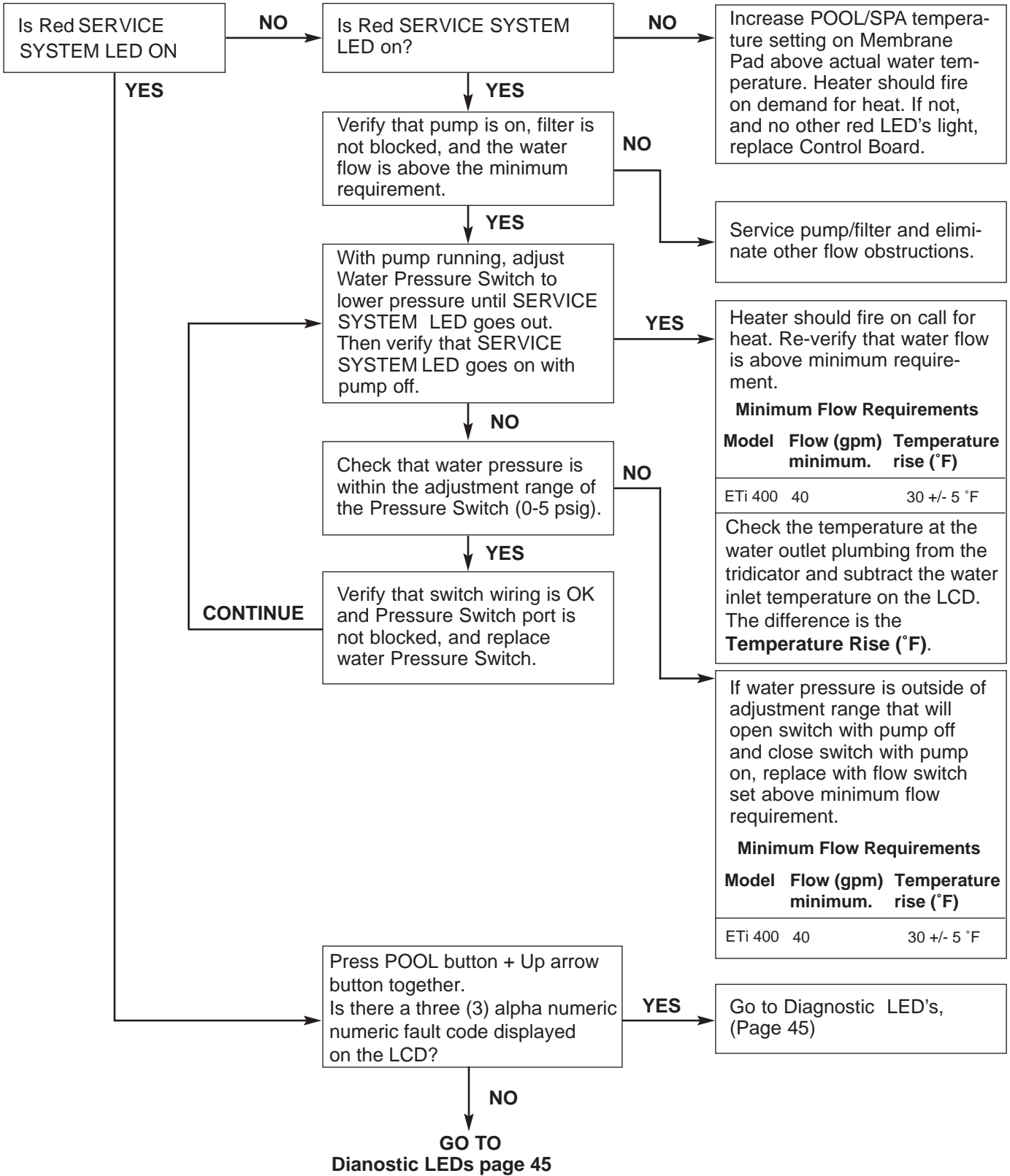

## Diagnostic LEDs: PS, HLS, TF, IGN, AFS, AG1, AG2, FS

### IMPORTANT! READ ME FIRST!

#### IMPORTANT! READ ME FIRST!!

If your heater is correctly connected to **240 Volts AC**, the Ignition Control Module (ICM) will convert the 240VAC to an intermittent pulse to the ignitor. Digital meters don't read this type of signal well. (An analog meter will give a better reading than a digital meter). If the ICM is bad, your volt-

meter will read either 0 VAC or 240 VAC. If your ICM is good, your meter will read some voltage between 0 and 240 VAC. Exactly what reading you get will depend on the meter, but with a good ICM, the reading won't be 0 VAC or 240 VAC, but somewhere in between.

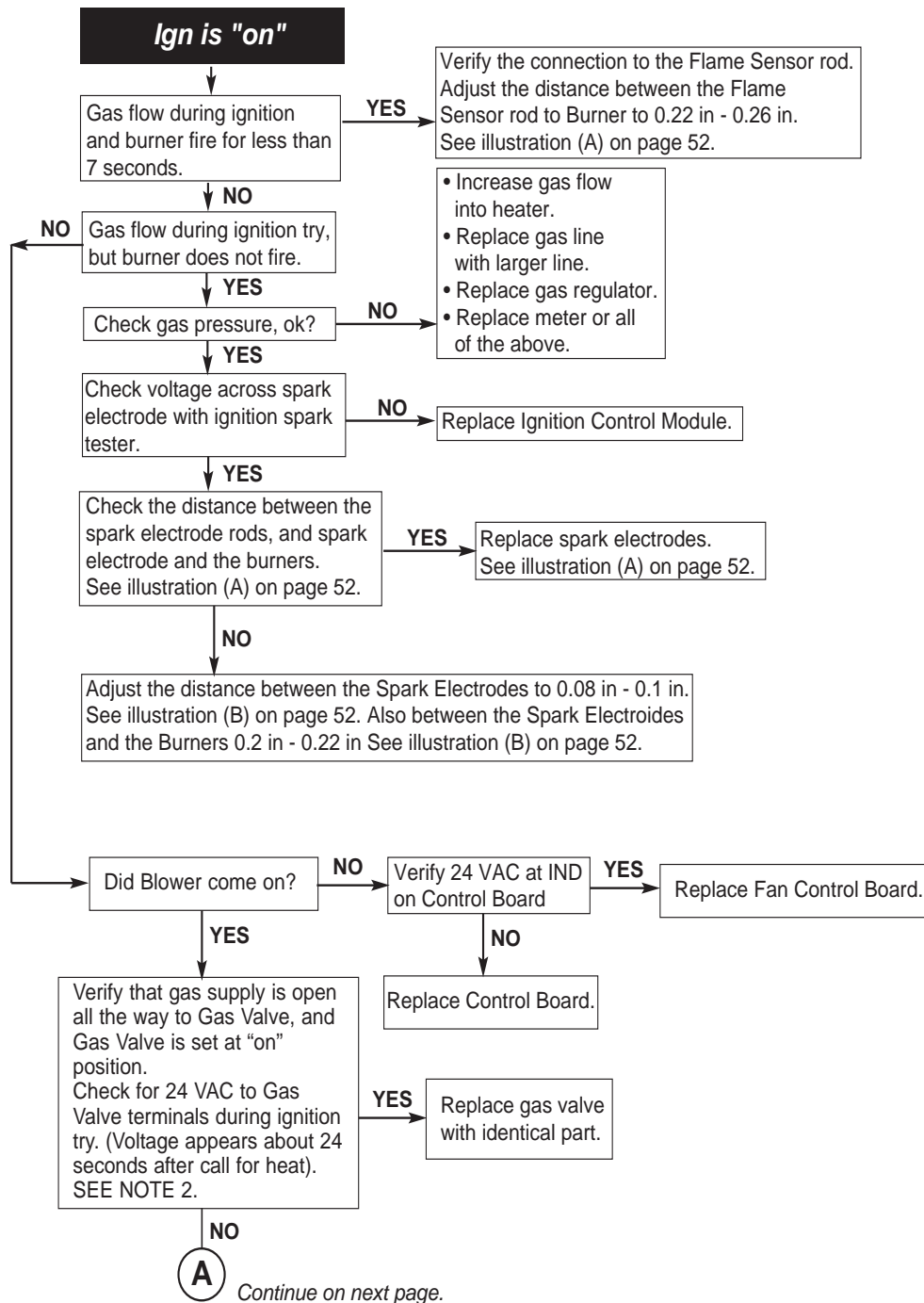

## Diagnostic LEDs: PS, HLS, TF, IGN, AFS, AG1, AG2, FS (Continued)

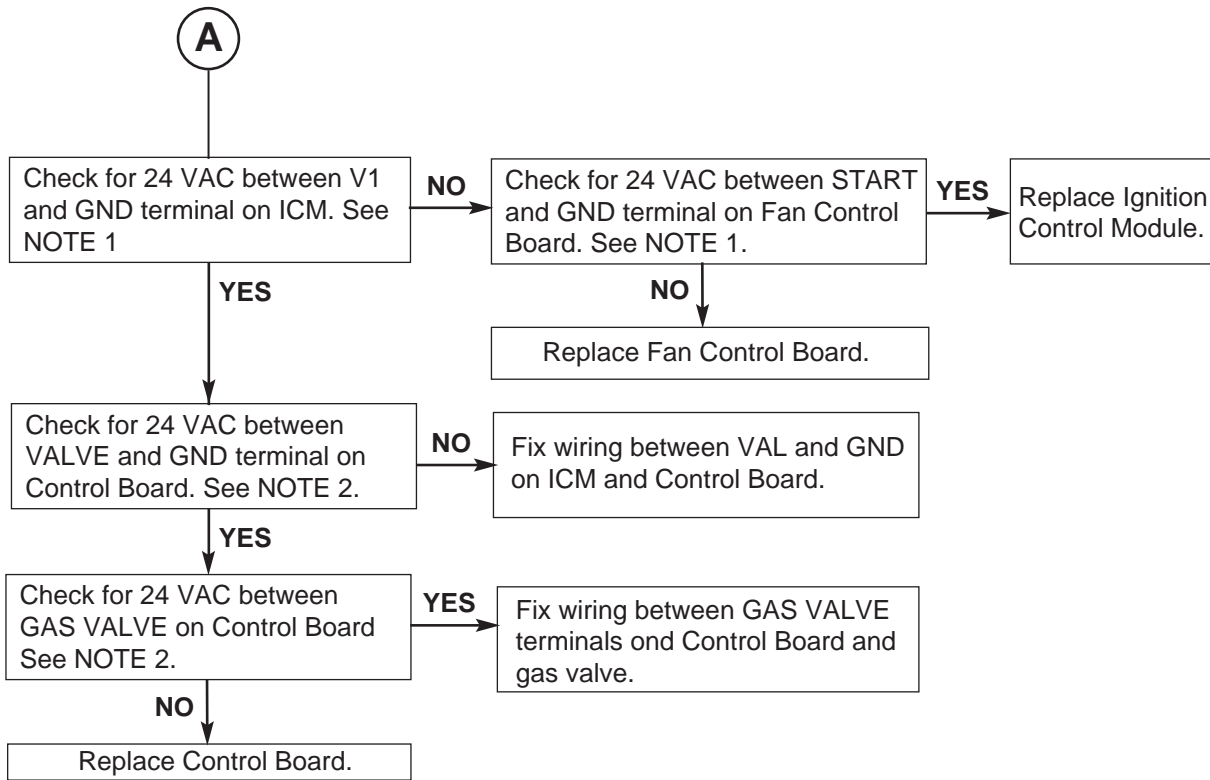

**NOTE 1:** Voltage appears immediately after call for heat, and may be on for only about 30 seconds.

**NOTE 2:** Voltage appears about 24 seconds after call for heat, and may be on for only about 7 seconds.

<p><b>⚠ CAUTION</b> Do not jumper a safety switch to remedy a failed switch.</p>	<p><b>NOTE:</b> ES1 is a spare and should be jumpered.</p>
--	--

## Diagnostic LEDs: PS, HLS, TF, IGN, AFS, AG1, AG2, FS

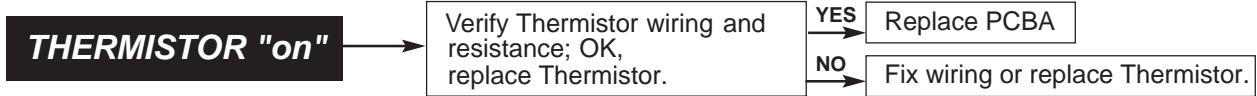
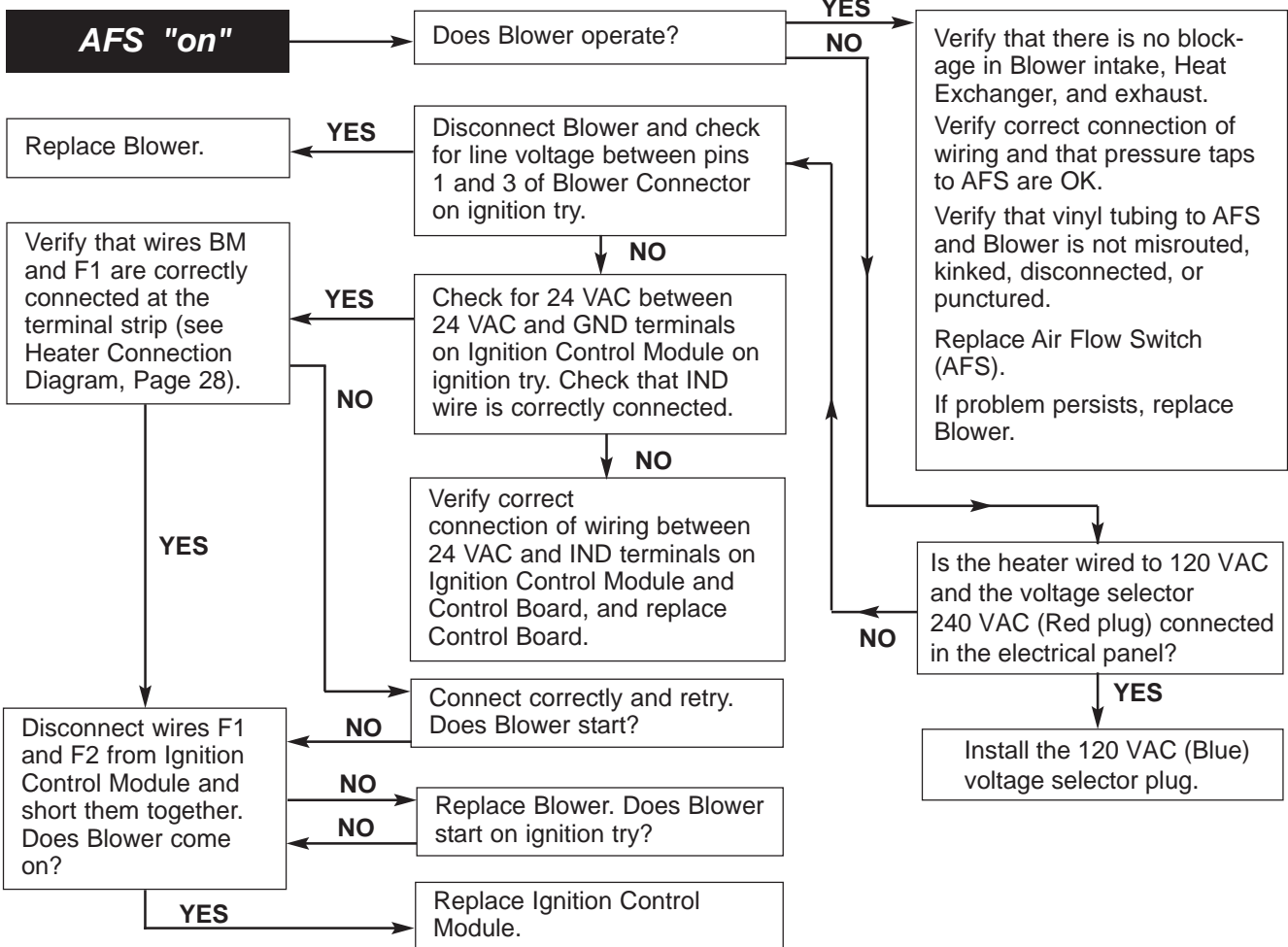
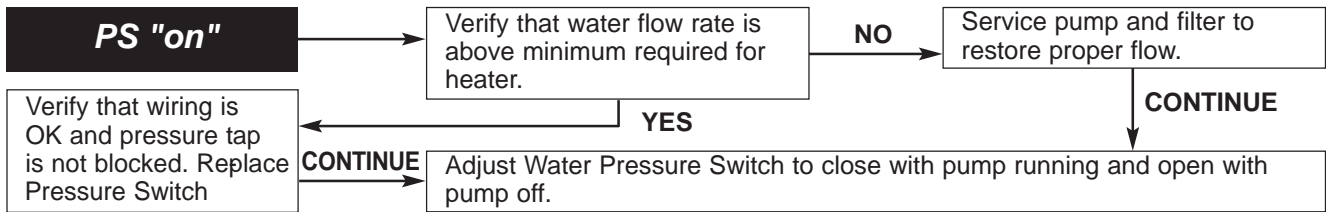
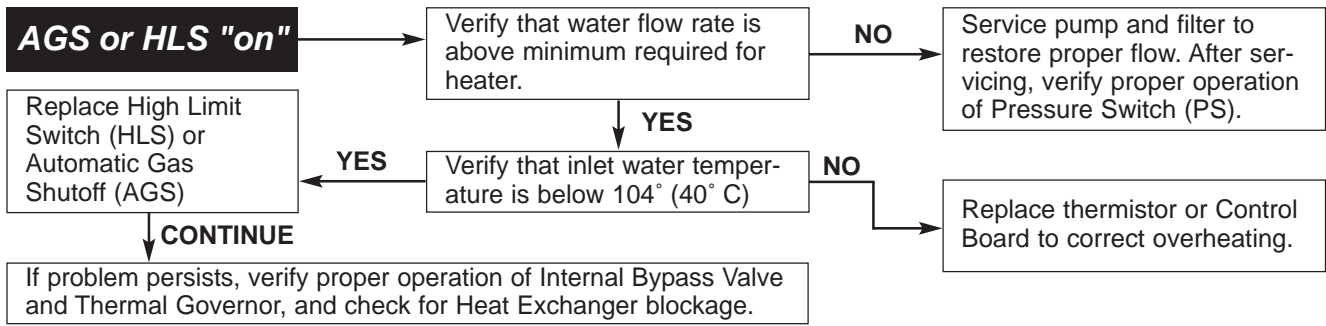

**CAUTION** Do not jumper a safety switch to remedy a failed switch. **NOTE:** ES1 is a spare and should be jumpered.

# Diagnostic LEDs: PS, HLS, TF, IGN, AFS, AG1, AG2, FS

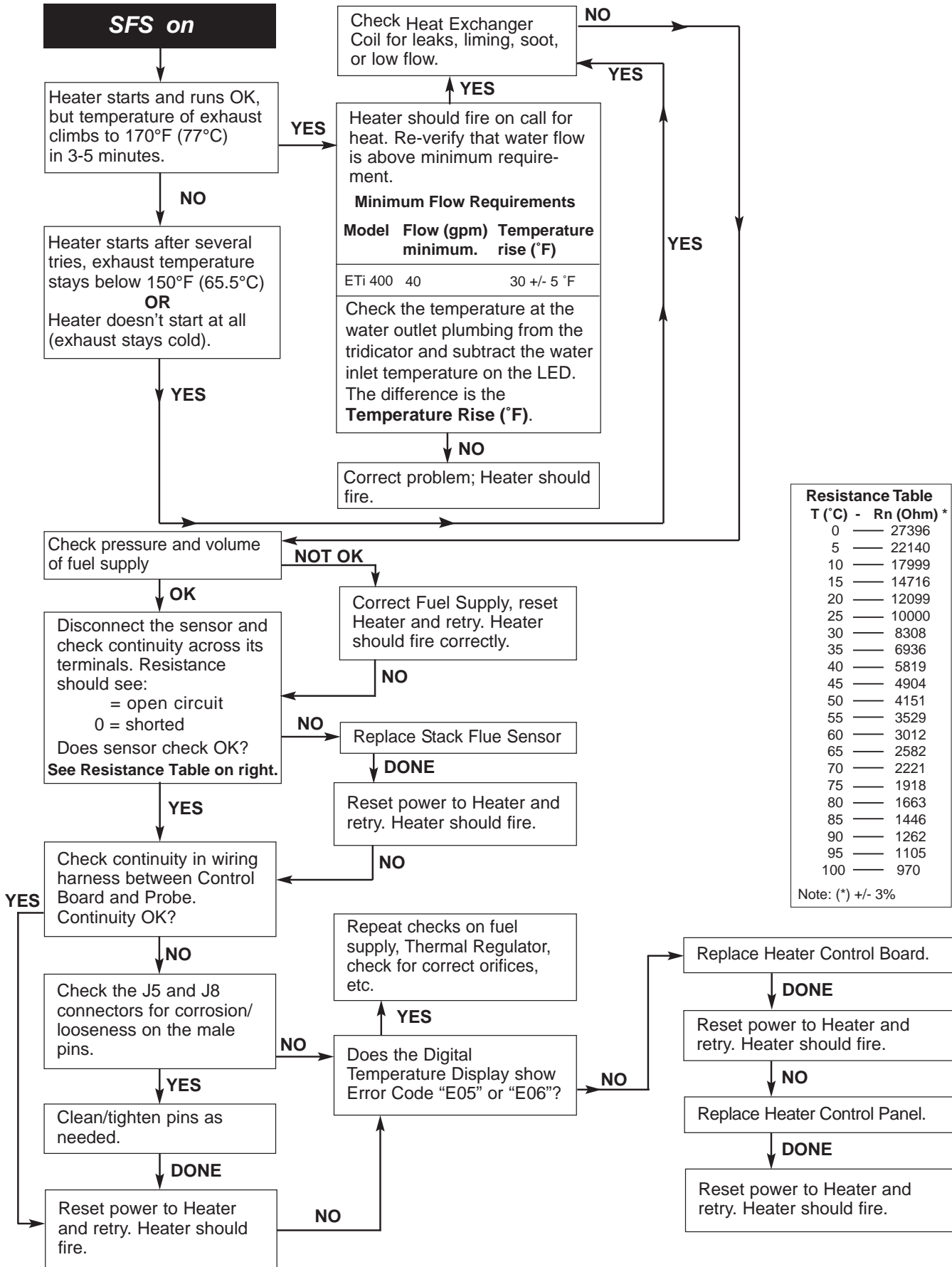

**Resistance Table**

T (°C) - Rn (Ohm) \*

0	27396
5	22140
10	17999
15	14716
20	12099
25	10000
30	8308
35	6936
40	5819
45	4904
50	4151
55	3529
60	3012
65	2582
70	2221
75	1918
80	1663
85	1446
90	1262
95	1105
100	970

Note: (\*) +/- 3%



## Diagnostic LEDs: PS, HLS, TF, IGN, AFS, AG1, AG2, FS

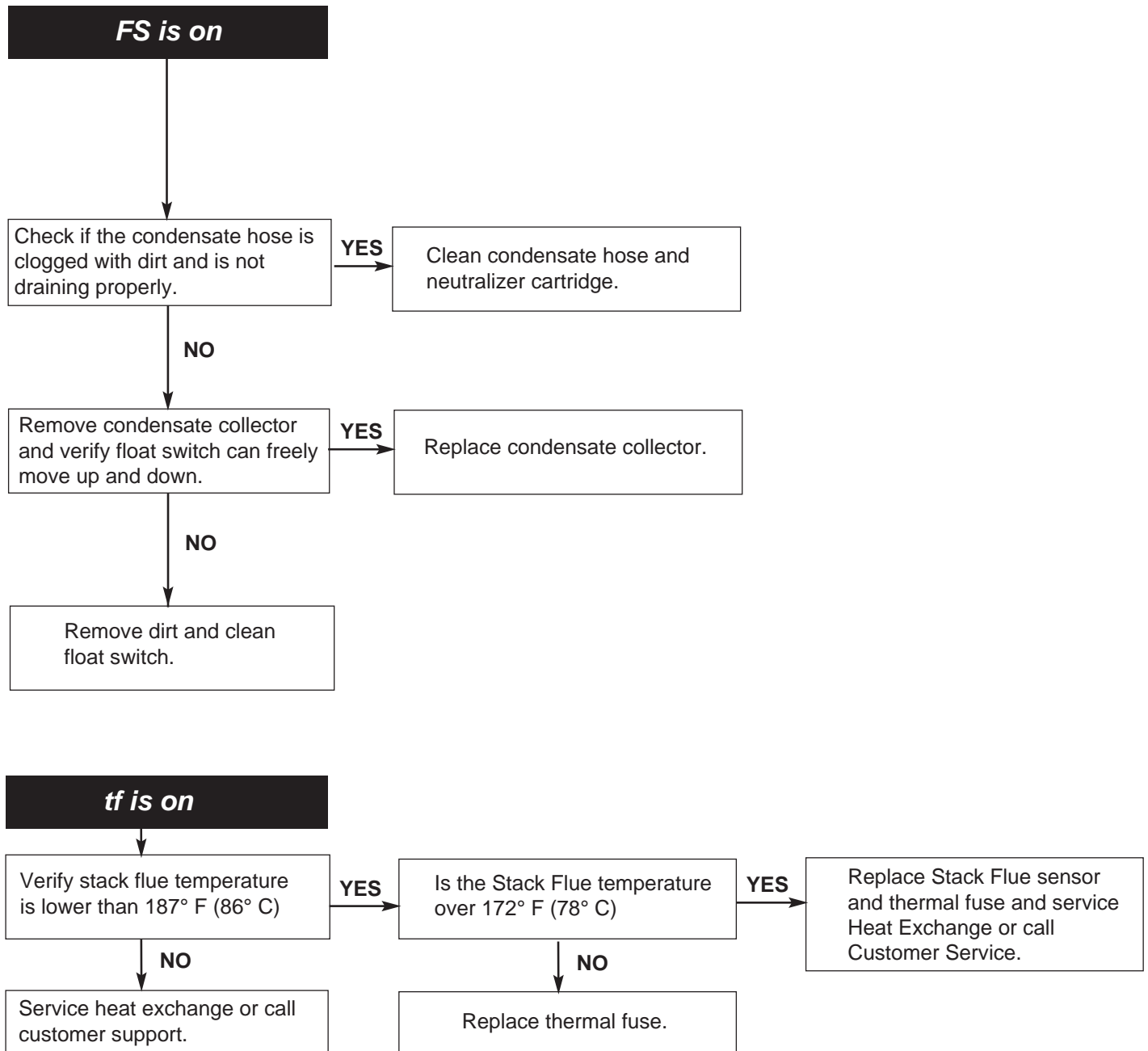

## Burner Troubleshooting

<b>SYMPTOM</b>	<b>CAUSE</b>	<b>REMEDY</b>
Loud, high-pitched whine	Flame is too rich.	Verify pressure tap between gas valve and blower inlet.  See page 16 and verify that the gas regulator setting is $-0.2''$ ( $-0.5\text{cm}$ ) wc.  Contact a qualified technician or service agency to replace the gas orifice.
Flame is “fluttery.” Exhaust may have acrid smell or burner may fail to stay lit.	Flame is too lean.	See page 16 and verify that the gas regulator setting is $-0.2''$ ( $-0.5\text{cm}$ ) wc.  Contact a qualified technician or service agency to replace the gas orifice.
Burner pulsates or surges, especially on ignition.	Exhaust vent is too long.	Reduce length of exhaust vent and/or number of elbows.
Combustion appears normal, but flame does not stay lit.	Flame current is not being sensed.	Check for wet or damaged igniter with low resistance to ground. Replace with new igniter.  Verify burner flameholder is properly grounded.  Replace Ignition Control Module.

## Heat Exchanger Troubleshooting

<b>SYMPTOM</b>	<b>CAUSE</b>	<b>REMEDY</b>
Boiling in heat exchanger. May be accompanied by “bumping” sounds.	Low water flow to heater  Heat exchanger plugged.  Bypass valve stuck open.	Service pump and or filter.  Service heat exchanger. Correct water chemistry.  Service bypass valve.

## Operator Control Panel Displays RNC Code

<b>SYMPTOM</b>	<b>CAUSE</b>	<b>REMEDY</b>
Operator control panel LCD displays the RNC code.	Neutralizer maintenance reminder.  The RNC code is displayed on the LCD to remind you to do the maintenance on the neutralizer cartridge.	To clear this code, press the OFF button to put the heater in off mode, then press and hold the OFF button for 5 seconds.  Contact a qualified technician or service agency to service the condensate neutralizer cartridge.

## Section 4: Maintenance and Care Instructions

### MAINTENANCE AND CARE INSTRUCTIONS

#### ⚠ WARNING

**Risk of fire or explosion from flammable vapors.** Do not store gasoline, cleaning fluids, varnishes, paints, or other volatile flammable liquids near heater or in the same room with heater.

The following maintenance is recommended every six months and at the start of every swimming season:

1. Inspect the heater panels and venting system to make sure that there are no obstructions to the flow of ventilating air or burner exhaust. Check that room air intakes are open and clear of obstructions.
2. Keep the area in and around the heater clear and free from combustible materials, gasoline and other flammable vapors and corrosive liquids.
3. Test the operation of the pressure relief valve by lifting the valve lever (if installed).
4. Test for proper operation of the water pressure switch. **See WATER PRESSURE SWITCH on page 14 for testing instructions.**
5. For enclosed installations, repeat the **Final Installation Check**, page 35. Check for evidence of joint leakage. Make sure that joints have not slipped partially or completely apart. Check pipe and fittings for cracks or breaks. The combustion air blower is permanently lubricated, and does not require periodic lubrication.

### TITANTOUGH™ HEAT EXCHANGER ASSEMBLIES ANNUAL INSPECTION

The following maintenance is recommended every 12 months and at the start of every swimming season:

1. The upper and lower TitanTough Heat Exchanger assembly must be inspected every 12 months and cleaned. It is recommended to call a qualified service technician to inspect the heat exchangers.

Inside heat exchanger assembly  
must be cleaned every 12 months

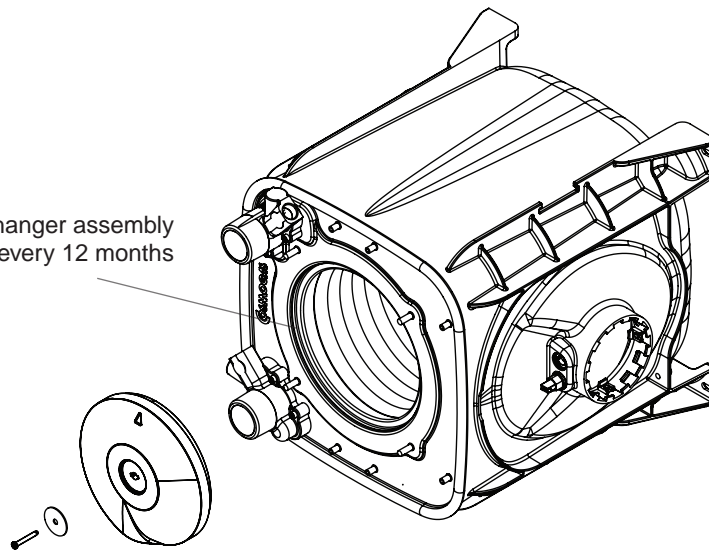

Heat Exchanger Assembly

## BURNER SPARK ELECTRODE AND FLAME SENSOR ROD ANNUAL INSPECTION

The following maintenance is recommended every 12 months and at the start of every swimming season:

- The Thermal Insulation must be checked every 12 months, and if necessary be replaced. Inspect the Thermal Insulation for signs of exterior damage to the device. It is recommended to call a qualified service technician to inspect the Thermal Insulation.

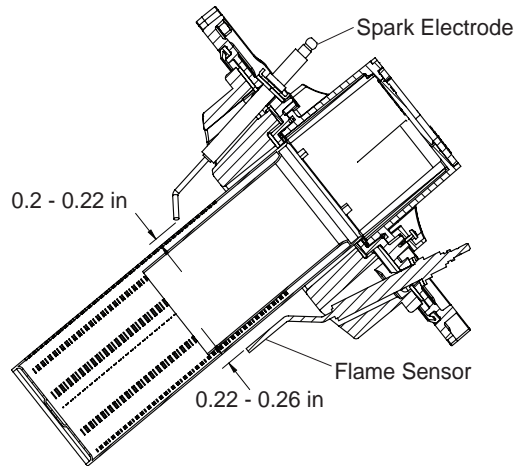

(A) Burner Spark Electrode

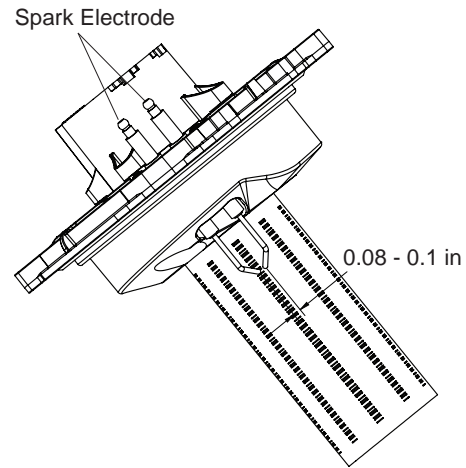

(B) Flame Sensor Rod

## PRESSURE RELIEF VALVE (50 PSI) (FACTORY INSTALLED)

To avoid water damage or scalding from operation of the pressure relief valve (see Figure 34), install a drain pipe in the outlet of the pressure relief valve that will direct water discharging from the valve to a safe place for disposal. Do not install any reducing couplings or valves in the drain pipe. The drain pipe must be installed so as to allow complete drainage from the valve and drain line. The relief valve should be tested at least once a year by lifting the valve lever.

### **⚠ WARNING**

**Explosion hazard.** Any heater installed with restrictive devices in the piping system downstream from the heater, (including check valves, isolation valves, flow nozzles, or therapeutic pool valving), must have a relief valve installed as described above.

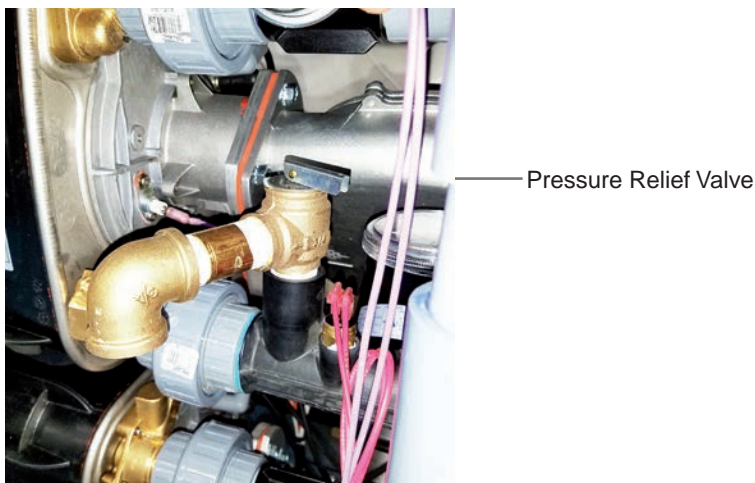

Figure 34.

## **AFTER START-UP**

### **CHECKING WATER FLOW**

#### **⚠WARNING**

**Fire or flooding hazard.** If the heater overheats and the burners fails to shut off, follow the instructions under **To Turn Off Gas to the Appliance, on page 13**, and call a qualified service technician to repair the heater.

After start-up, the outlet water pipe should feel slightly warmer than the inlet pipe. If it feels hot, or if you hear the water in the heater boiling, there may not be enough water flow to the appliance. Make sure that the filter is not plugged. If water temperature remains high but the unit continues to operate, turn off the appliance and call your service technician.

### **SPRING AND AUTUMN OPERATION**

If the pool is only used occasionally, lower the pool thermostat to 68° F (20° C) and leave the heater on. This will keep the pool and the surrounding ground warm enough so that the heater should restore the pool to a comfortable temperature within about one day.

### **WINTER OPERATION AND WINTERIZATION**

**Notice:** Pentair recommends to use a blower to remove all of the water out of the heater in areas subject to freezing temperatures while the heater is not being used.

#### **⚠WARNING**

**Explosion hazard.** Purging the system with compressed air can cause components to explode, with risk of severe injury or death to anyone nearby. Use only a low pressure (below 5 PSI or 35 kPa), high volume blower when air purging the heater,

#### **⚠CAUTION**

- If the heater has been drained for freezing condition, **DO NOT TURN ON** the heater until the system is circulating water.
- Water trapped in the heat exchanger can result in freeze damage to the exchanger or headers. Freeze damage is specifically not covered by the warranty.
- When starting the heater for the swimming season with a water temperature below 50° F (10° C), the heater may be used to heat the water; however, make sure that the heater operates continuously until the water temperature reaches the heater's minimum setting of 68° F (20° C). During cold weather, if there is no danger of freezing, operate the filter pump continuously even if the heater is not operating. If air temperatures are expected to drop below freezing (32° F/0° C), shut down the heater and winterize it.

For outdoor heaters in freezing climates, shut the heater down and drain it for winter as follows:

1. Turn off the electrical supply to the heater and pump by the main circuit breakers.
2. Close main gas control valve and manual gas valve (located outside the heater). See Figure 14 on page 20.
3. Open the main DRAIN COCK located on the bottom of the manifold adapter and drain the heater exchanges, internal CPVC plumbing, and manifold adapter completely.
4. If the heater is **below pool water level**, be sure to close the isolation valves to prevent from draining the pool. Isolation valves are not required and should not be used on heaters installed above pool water level, except when needed for winterization valves.
5. Remove the two WATER PRESSURE SWITCHES located in the plumbing inlet assembly (see page 14). Plug the water pressure switches ports to prevent insects and dirt from getting into the plumbing inlet assembly  
*Continue with Step 6 on next page.*

6. Drain the plastic inlet/outlet manifold through the outlet pipe. If the pipe does not drain naturally to the pool, install a drain cock in the outlet pipe to drain the manifold.
7. Use a blower to remove all remaining water in the heater.
8. Cover air inlet grate with a plastic bag to prevent bugs, leaves, etc., from getting into the heater.

**NOTICE: Water trapped in the heater can cause freeze damage. Allowing the heater to freeze voids the warranty.**

## RETURN THE HEATER TO SERVICE

### To return the heater to service after winterizing:

1. Connect the INLET and OUTLET unions to the system plumbing, see page 16. Check that they are connected correctly and there are no water leaks.
2. Reinstall the two WATER PRESSURE SWITCHES in the CPVC plumbing inlet assembly, see page 16
3. Place the DRAIN PLUG back into the port at the manifold assembly.
4. Before starting the heater, circulate water through the heater for several minutes until all air noises stop. See also **BEFORE START-UP** (page 12) and **CARE AND MAINTENANCE** (page 51).

*See additional notes under Important Notices in Introduction page 12.*

## MAINTAINING POOL TEMPERATURE

To maintain pool temperature, make sure that the heater switch and valving are reset to pool settings after using the spa.

### ENERGY SAVING TIPS

1. Keep the pool or spa covered when not in use. This will reduce heating costs, reduce water evaporation, conserve chemicals and reduce load on the filtering system.
2. Reduce pool thermostat to 78° F (25° C) or lower; reduce spa temperature to 100° F (38° C). This is accepted as being the most healthy temperature for swimming by the American Red Cross.
3. Use a time clock to start the filter pump at 6 a.m. or later. The swimming pool loses less heat after daybreak.
4. For pools used only on weekends, lower the thermostat setting by 10° F to 15° F (5° C to 8° C) during the week to reduce heat loss. A properly sized heater will restore normal temperature within one day.
5. Turn the heater off when the pool will not be used for an extended period.
6. Follow a regular program of preventive maintenance for the heater each new swimming season. Check operation of the heater and its controls.

## CHEMICAL BALANCE

### ***POOL AND SPA WATER***

Your pool heater was designed specifically for your spa or pool and will give you many years of trouble-free service, provided you keep your water chemistry in proper condition.

Water chemistry should follow good swimming pool water chemistry practices. When using a chlorinator, install it down stream from the heater and at a lower level than the heater outlet. Install a corrosion resistant positive seal “Check Valve”, (P/N R172288), between the heater and the chlorinator to prevent concentrated chemicals from back-siphoning into the heater. Back-siphoning is most likely to occur when the pump stops, creating a pressure-suction differential. Do NOT sanitize the pool by putting chlorine tablets or sticks into the skimmer(s). When the pump is off, this will cause a high concentration of chlorine to enter the heater, which could cause corrosion damage to the heat exchanger.

Three major items that can cause problems with your pool heater are: improper pH, disinfectant residual, and total alkalinity. These items, if not kept properly balanced, can shorten the life of the heater and cause permanent damage.

### **⚠ CAUTION**

**Heat exchanger damage resulting from chemical imbalance is not covered by the warranty.**

### **WHAT A DISINFECTANT DOES**

Two pool guests you do not want are algae and bacteria. To get rid of them and make pool water sanitary for swimming - as well as to improve the water’s taste, odor and clarity - some sort of disinfectant must be used.

Chlorine and bromine are universally approved by health authorities and are accepted disinfecting agents for bacteria control.

### **WHAT IS A DISINFECTANT RESIDUAL?**

When you add chlorine or bromine to the pool water, a portion of the disinfectant will be consumed in the process of destroying bacteria, algae and other oxidizable materials. The disinfectant remaining is called chlorine residual or bromine residual. You can determine the disinfectant residual of your pool water with a reliable test kit, available from your local pool supply store.

You must maintain a disinfectant residual level adequate enough to assure a continuous kill of bacteria or virus introduced into pool water by swimmers, through the air, from dust, rain or other sources.

## CHEMICAL BALANCE (continued)

It is wise to test pool water regularly. Never allow chlorine residual to drop below 0.6 ppm (parts per million). The minimum level for effective chlorine or bromine residual is 1.4 ppm.

**pH** - The term pH refers to the acid/alkaline balance of water expressed on a numerical scale from 0 to 14. A test kit for measuring pH balance of your pool water is available from your local pool supply store; see Table 7 below.

Muriatic Acid has a pH of about 0. Pure water is 7 (neutral). Weak Lye solution have a pH of 13-14.

**RULE:** 7.4 to 7.6 is a desirable pH range. It is essential to maintain correct pH, see Table 7 below.

### If pH becomes too high (over alkaline), it has these effects:

1. Greatly lowers the ability of chlorine to destroy bacteria and algae.
2. Water becomes cloudy.
3. There is more danger of scale formation on the plaster or in the heat exchanger tubing.
4. Filter elements may become blocked.

### If pH is too low (over acid) the following conditions may occur:

1. Excessive eye burn or skin irritation.
2. Etching of the plaster.
3. Corrosion of metal fixtures in the filtration and recirculation system, which may create brown, blue, green, or sometimes almost black stains on the plaster.
4. If you have a sand and gravel filter, the alum used as a filter aid may dissolve and pass through the filter.

**CAUTION:** *Do not test for pH when the chlorine residual is 3.0 ppm or higher, or bromine residual is 6.0 ppm or higher. See your local pool supply store for help in properly balancing your water chemistry.*

**RULE:** Chemicals that are acid lower pH. Chemicals that are alkaline raise pH.

### ALKALINITY High or Low:

Total alkalinity is a measurement of the total amount of alkaline chemicals in the water, and control pH to a great degree. It is not the same as pH which refers merely to the relative alkalinity/acidity balance. Your pool water's total alkalinity should be 100 - 140 ppm to permit easier pH control. A total alkalinity test is simple to perform with a reliable test kit. You will need to test about once a week and make proper adjustments until alkalinity is in the proper range. Then, test only once every month or so to be sure it is being maintained. See your local pool dealer for help in properly balancing the water chemistry.

## WATER CHEMISTRY PARAMETERS

Disinfectant levels	Minimum	Ideal	Maximum
Free Chlorine, ppm	1.0	2.0-3.0	4.0**
Salt, ppm	2000	3200	5000
Combined Chlorine, ppm	None	None	0.2
Bromine, ppm	2.0	4-6	10.0
Other Sanitizers	Levels not established. Consult local health department before use.		
<b>Chemical Values</b>			
pH	7.2	7.4-7.6	7.8**
Total Alkalinity (Buffering), ppm as CaCO <sub>3</sub>	60	80-100	180
Salt ppm	2000	3200	5000**
Total Dissolved Solids, ppm	N/A	N/A	1,500 ppm > TDS at startup*
Calcium Hardness, ppm, as CaCO <sub>3</sub>	150	200-400	500-1,000
Heavy Metals	None	None	None
<b>Biological Values</b>			
Algae	None	None	None

Table 7.

\*Start-up TDS includes source water TDS and any other inorganic salt added at start-up.

**NOTE (\*\*):** Failure to adhere to the listed water chemistry parameters may result in premature failure of the heat exchanger and will void the warranty.



**ETI™ 400 HEATER REPLACEMENT PARTS LIST**

Item	Description	Quantity	Part Number
1	Fan Control Board	1	475978
2	Membrane pad	1	475984
3	Automatic Gas Shut-Off Switch (AGS) 150°F	1	475985
4	Air pressure switch	1	475987
5	Wire harness	1	475996
6	Thermal fuse	1	475998
7	Stack flue sensor	2	475601
8	Spark electrodes	1	475989
9	Spark Electrodes cables	1	475982
10	Condesate assembly/float switch	1	475980
11	HX and Chimney gaskets	1	475615
12	Heat exchanger screws	1	475606
13	Plug 120/240 V	1	475979
14	Tridicator Gauge	1	475603
15	Air orifice	1	475604
16	Heater gasket kit	1	475973
17	Air intake Kit	1	475971
18	Gas side panel	1	475608
19	Water manifold panel	1	475609
20	Control board panel	1	475610
21	Latch assy	1	475611
22	Condensate neutralizer cartridge kit	1	475612
23	Inlet plumbing assembly	1	475613
24	Outlet plumbing assembly	1	475614
25	Exhaust assembly	1	475617
26	Terminal board	1	42001-0056S
27	Fireman's Switch Fuse (1.25 amps)	1	32850-0099
28	Thermistor, water sensor	1	42001-0053S
29	Water pressure switch	1	42001-0060S
30	Dual voltage transformer	1	42001-0107S
31	Pressure relief valve	1	475618
32	Control cover	1	475619
33	Vent cap exhaust	1	475620
34	Water bypass assy	1	475621
35	Vent socket	1	475622
36	TitanTough Heat Exchanger	1	475623
37	Burner	1	475624
38	Blower	1	476000
39	Gas valve	1	476001
40	3/4" Union	1	38404-4097S
41	High Limit Switch	1	42001-0063S
42	Drain plug	1	U178-920P
43	Manifold	1	476002
44	Manifold-Enlosure Fasteners	1	476003
45	Hold down bracket kit	1	476004
46	Propane gas orifice kit	1	476040

# ETI™ 400 HEATER GENERAL REPLACEMENT PARTS

Note: Item 45 not shown.

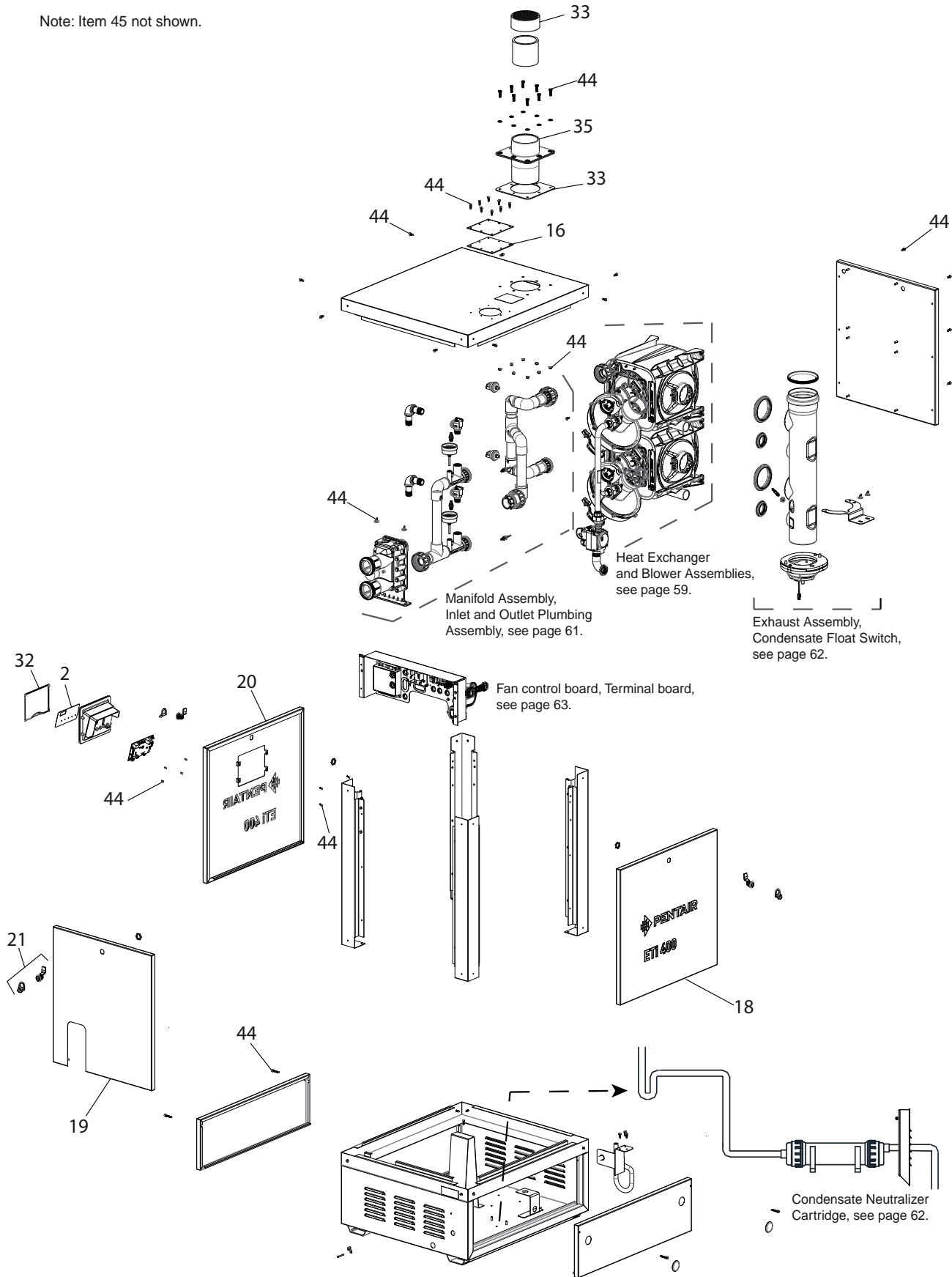

**ETI™ 400 HEATER HEAT EXCHANGER AND BLOWER ASSEMBLIES REPLACEMENT PARTS**

Note: Item 11, 12, 17, 37 not shown.

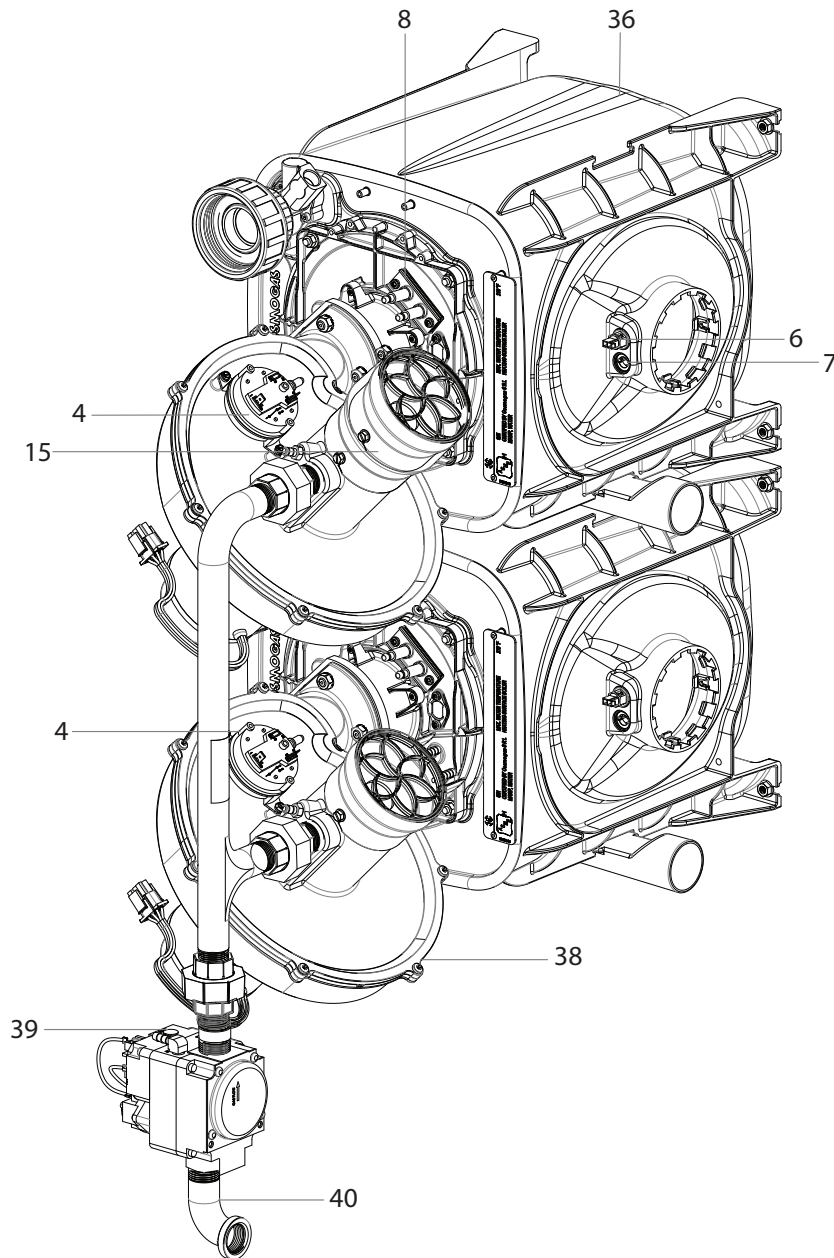

Heat Exchanger and Blower Assemblies

**ETI™ 400 HEATER HEAT EXCHANGER ASSEMBLY REPLACEMENT PARTS (CONTINUED)**

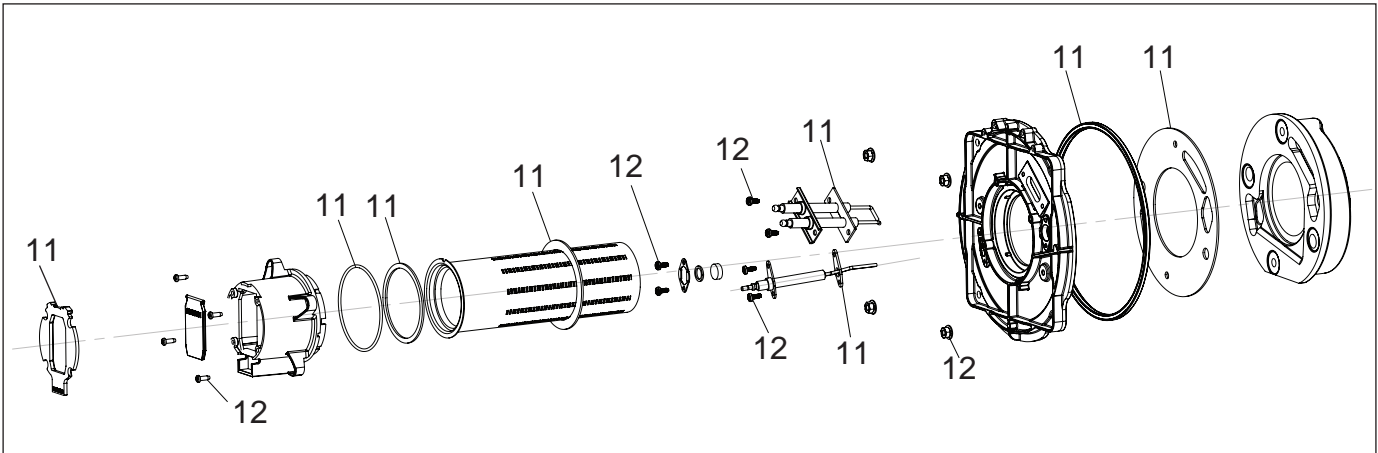

Heat Exchanger Assembly

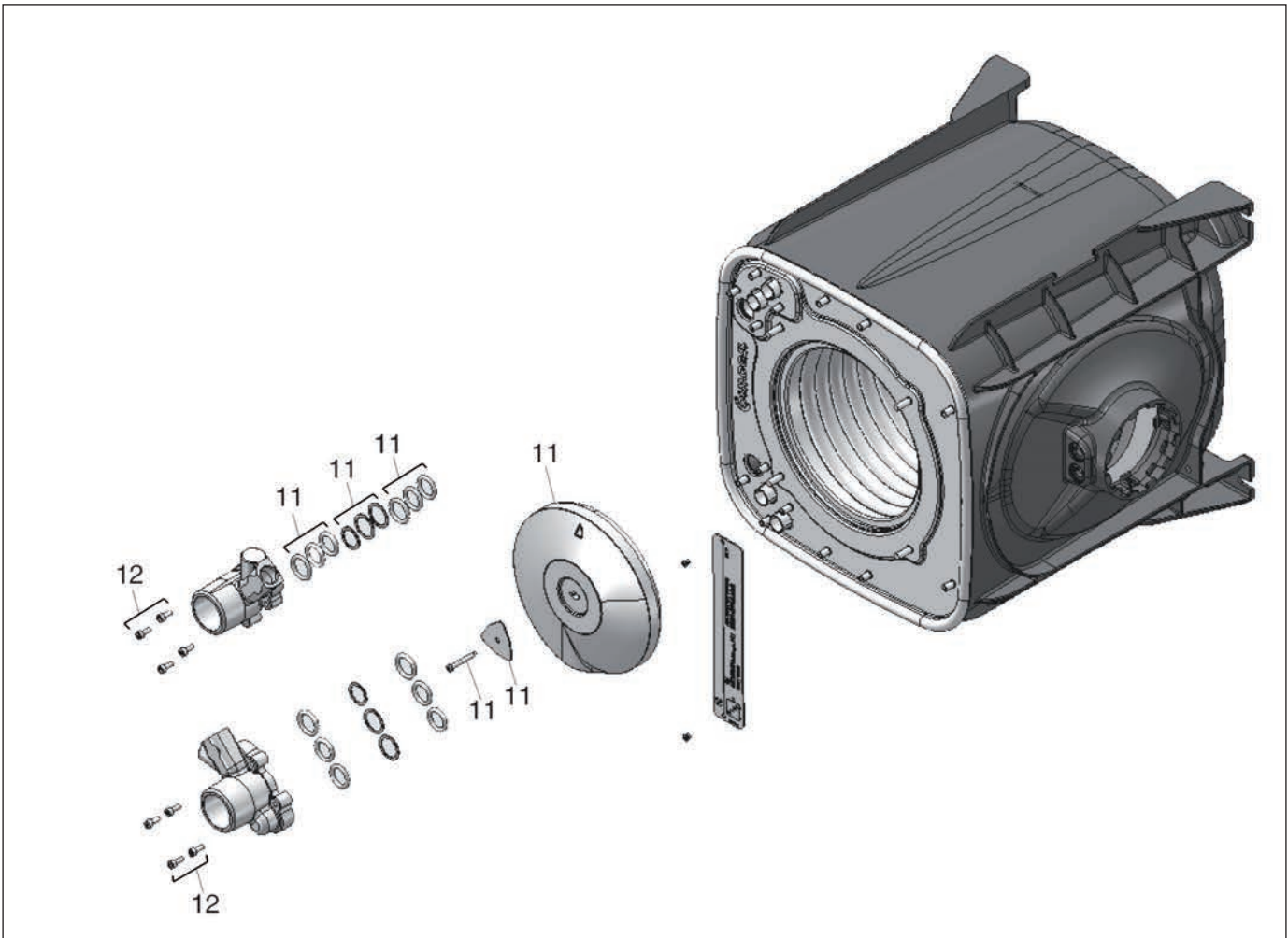

Heat Exchanger Assembly

**ETI™ 400 HEATER MANIFOLD ASSEMBLY - INLET AND OUTLET PLUMBING ASSEMBLY**

**REPLACEMENT PARTS**

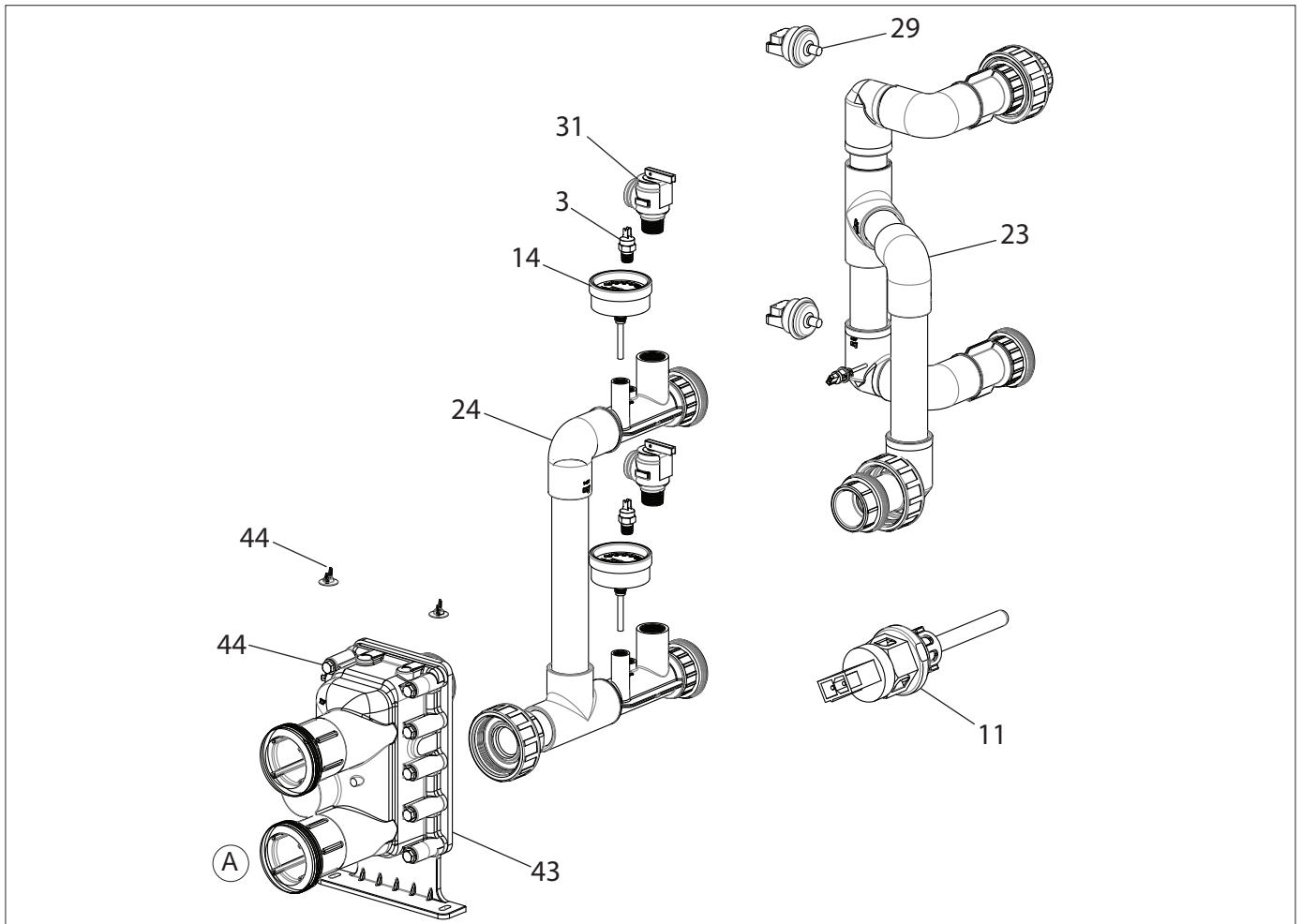

Manifold Assembly - Inlet and Outlet Plumbing Assembly

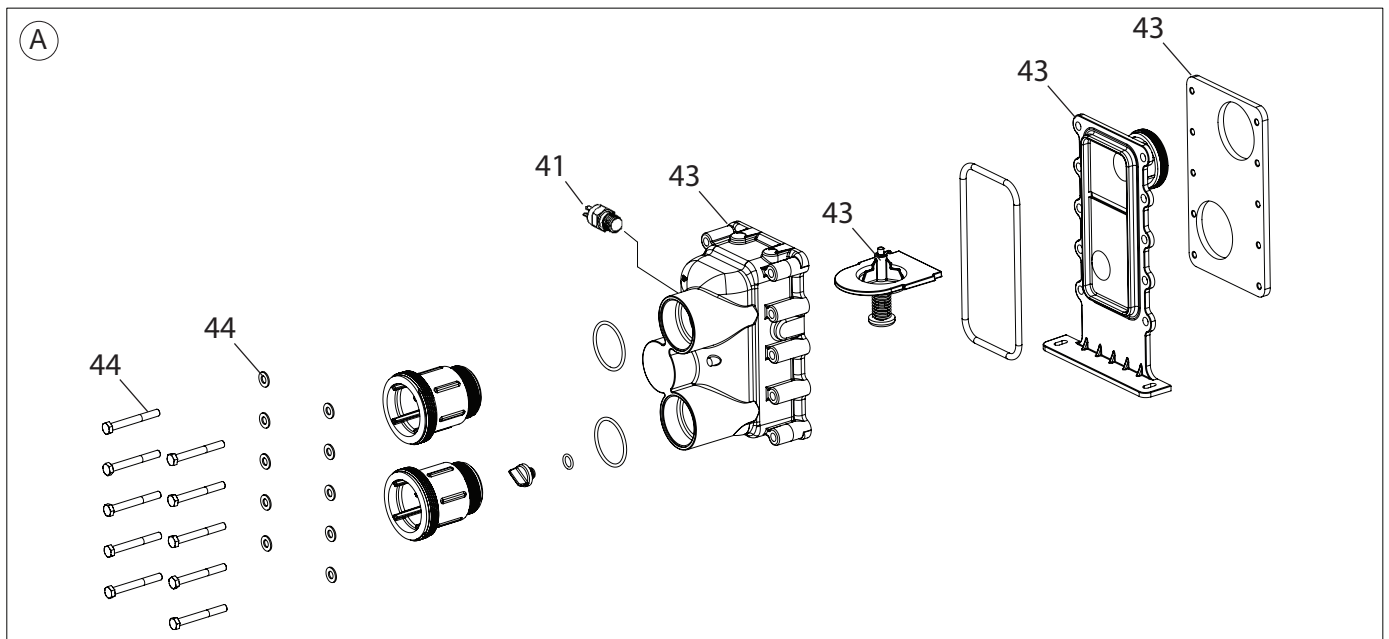

Manifold Assembly

**ETI™ 400 HEATER CONDENSATE AND EXHAUST ASSEMBLY REPLACEMENT PARTS**

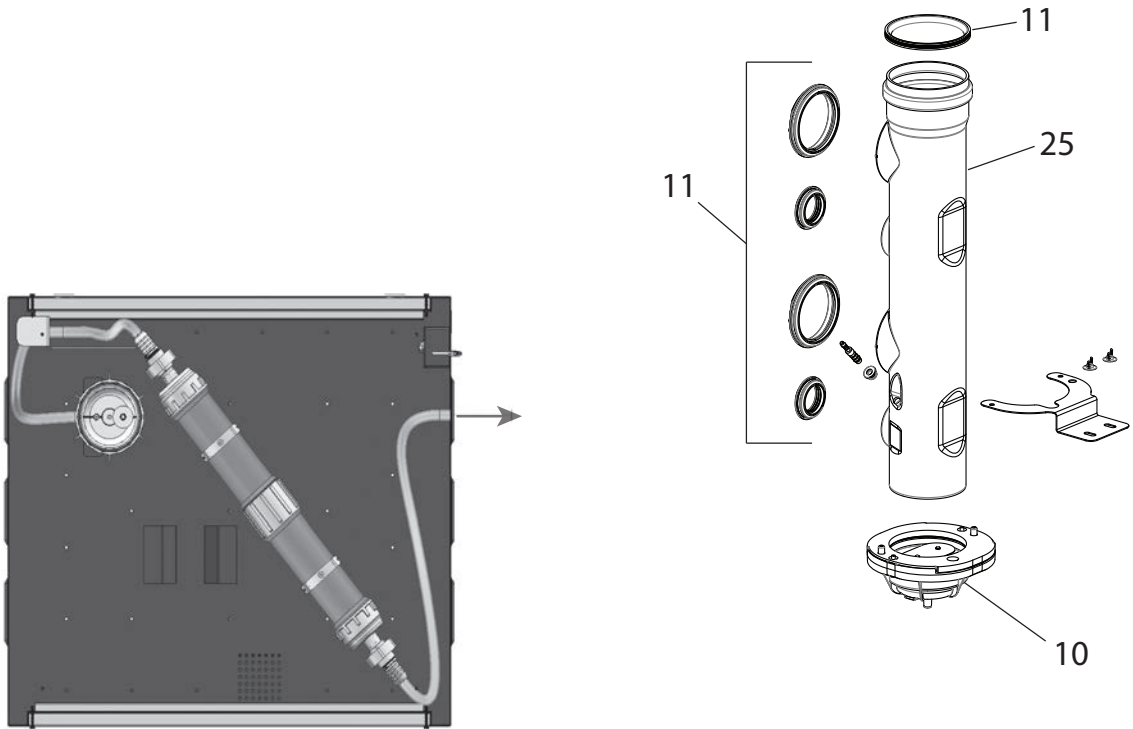

Condensate Neutralizer Cartridge (Optional, P/N 475612 sold separately). The cartridge may be mounted to the base of the heater for an outdoor installation.

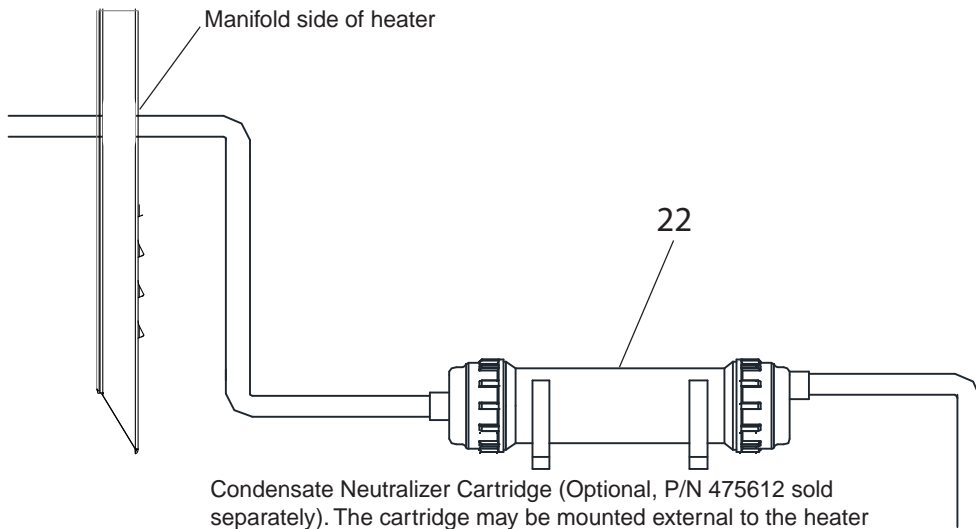

Condensate Neutralizer Cartridge (Optional, P/N 475612 sold separately). The cartridge may be mounted external to the heater for an indoor installation.

Condensate Neutralizer Cartridge Assembly and Exhaust Assembly.

**ETI™ 400 HEATER OPERATOR CONTROL PANEL ASSEMBLY REPLACEMENT PARTS**

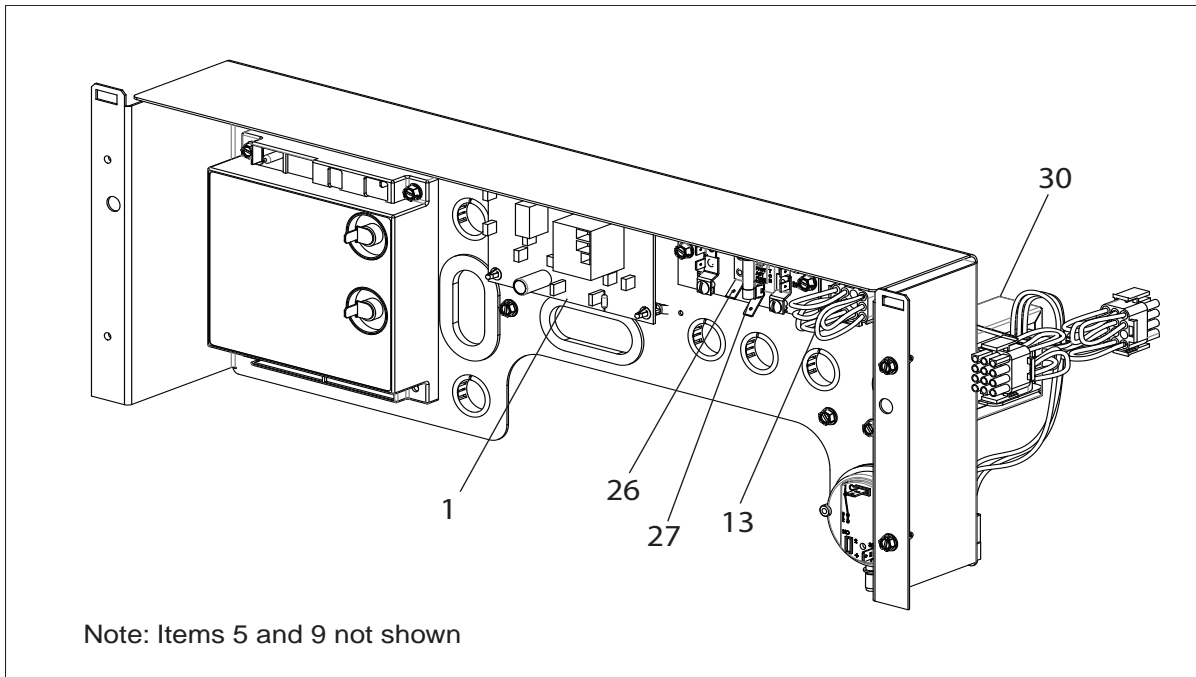

Fan Control Board and Terminal Board



1620 HAWKINS AVE., SANFORD, NC 27330 • (919) 566-8000  
10951 WEST LOS ANGELES AVE., MOORPARK, CA 93021 • (805) 553-5000  
[www.pentairpool.com](http://www.pentairpool.com)

All Pentair trademarks and logos are owned by Pentair or one of its global affiliates. ETi™, TitanTough™, IntelliTouch®, EasyTouch®, are trademarks and/or registered trademarks of Pentair Water Pool and Spa, Inc. and/or its affiliated companies in the United States and/ or other countries. Unless expressly noted, names and brands of third parties that may be used in this document are not used to indicate an affiliation or endorsement between the owners of these names and brands and Pentair Water Pool and Spa, Inc. Those names and brands may be the trademarks or registered trademarks of those third parties. Because we are continuously improving our products and services, Pentair reserves the right to change specifications without prior notice. Pentair is an equal opportunity employer.

© 2016 Pentair Water Pool and Spa, Inc. All rights reserved. This document is subject to change without notice.



P/N 475349 Revision A. 9/2016