

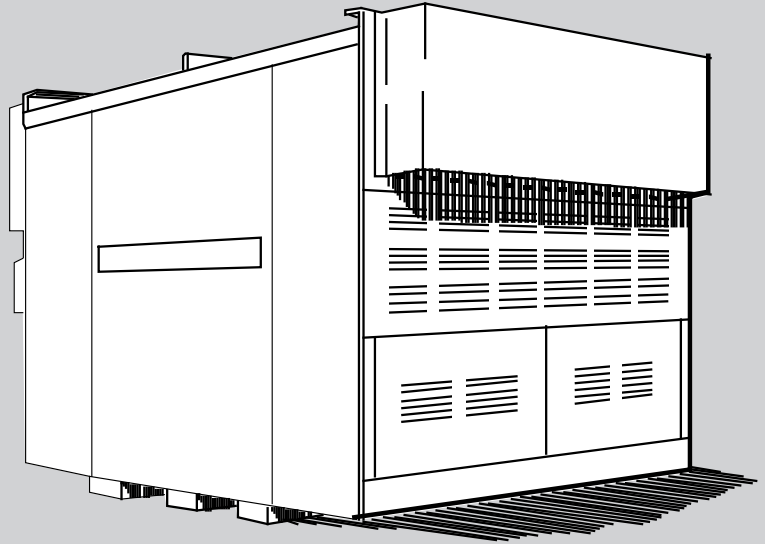

MEGATHERM[®] COMMERCIAL HEATER

MODEL MT
SIZES 2000-5000 MBTU/H

INSTALLATION AND OPERATION INSTRUCTIONS



THESE INSTRUCTIONS ARE TO BE STORED IN
THE POCKET PROVIDED ON THE HEATER.

FOR YOUR SAFETY: This product must be installed and serviced by a professional service technician, qualified in hot water boiler installation and maintenance. Improper installation and/or operation could create carbon monoxide gas in flue gases which could cause serious injury, property damage, or death. Improper installation and/or operation will void the warranty. For indoor installations, as an additional measure of safety, Pentair strongly recommends installation of suitable Carbon Monoxide detectors in the vicinity of this appliance and in any adjacent occupied spaces.

⚠ WARNING

If the information in this manual is not followed exactly, a fire or explosion may result causing property damage, personal injury or loss of life.

Do not store or use gasoline or other flammable vapors and liquids in the vicinity of this or any other appliance.

WHAT TO DO IF YOU SMELL GAS

- Do not try to light any appliance.
- Do not touch any electrical switch; do not use any phone in your building.
- Immediately call your gas supplier from a nearby phone. Follow the gas supplier's instructions.
- If you cannot reach your gas supplier, call the fire department.

Installation and service must be performed by a qualified installer, service agency, or gas supplier.

⚠ AVERTISSEMENT

Assurez-vous de bien suivre les instructions données dans cette notice pour réduire au minimum le risque d'incendie ou d'explosion ou pour éviter tout dommage matériel, toute blessure ou la mort.

Ne pas entreposer ni utiliser d'essence ni d'autres vapeurs ou liquides inflammables dans le voisinage de cet appareil ou de tout autre appareil.

QUE FAIRE SI VOUS SENTEZ UNE ODEUR DE GAZ:

- Ne pas tenter d'allumer d'appareils.
- Ne touchez à aucun interrupteur. Ne pas vous servir des téléphones dans le bâtiment où vous vous trouvez.
- Appelez immédiatement votre fournisseur de gaz depuis un voisin. Suivez les instructions du fournisseur.
- Si vous ne pouvez rejoindre le fournisseur de gaz, appelez le service des incendies.

L'installation et l'entretien doivent être assurés par un installateur ou un service d'entretien qualifié ou par le fournisseur de gaz.

TABLE OF CONTENTS

SECTION 1.

General Information

1A.	Introduction.....	3
1B.	Heater Identification.....	3

SECTION 2.

Installation

2A.	Boiler Placement	4
2B.	Installation of Indoor Boilers	4
2B-1.	Combustion Air Supply	4
2B-2.	Venting.....	5
2C.	Installation of Outdoor Water Units.....	5
2D.	Freeze Protection	6
2E.	Gas Supply and Piping	6
2F.	Electrical Wiring.....	7
2G.	Piping of System to Boiler	7
2H.	General Water Piping	7
2I.	Boiler By-Pass Piping	8
2J.	Automatic Chlorinators	8
2K.	Pressure Switch.....	8

SECTION 3.

Operation

3A.	Initial Start Up	9
3A-1.	Initial Filter Cycle on a New Pool.....	9
3A-2.	Starting Instructions.....	9
3A-3.	Hi-Limit Checkout	10
3B.	To Start Up System (See Section 3A for Initial Start Up).....	10
3C.	To Turn Off Boiler.....	10
3D.	Spring and Fall Operation.....	10

3E.	Winter Operation	10
3E-1.	Draining Boiler Before Freezing	10
3E-2.	Improper Use of the Boiler.....	10
3F.	Time Clock Operation	11
3G.	Spa (Hot Tub) Safety Rules.....	11
3H.	Periodic Service.....	11
3I.	Pool Water Chemistry.....	11

SECTION 4.

Maintenance

.....	12
-------	----

SECTION 5.

Troubleshooting and Analysis of Service Problems

.....	13
-------	----

SECTION 6.

Conversion of Model MT Pool Boilers From Indoor to Outdoor Models

6A.	SECTION I	14
6B.	SECTION II.....	14

SECTION 7.

Parts Description and Order Numbers

.....	16
-------	----

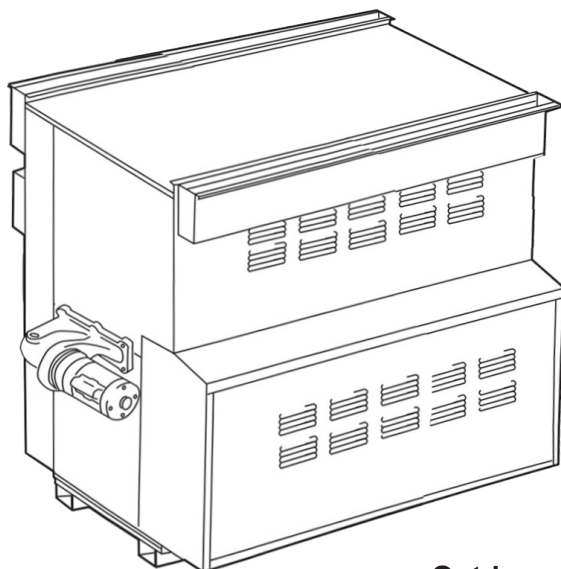

Outdoor

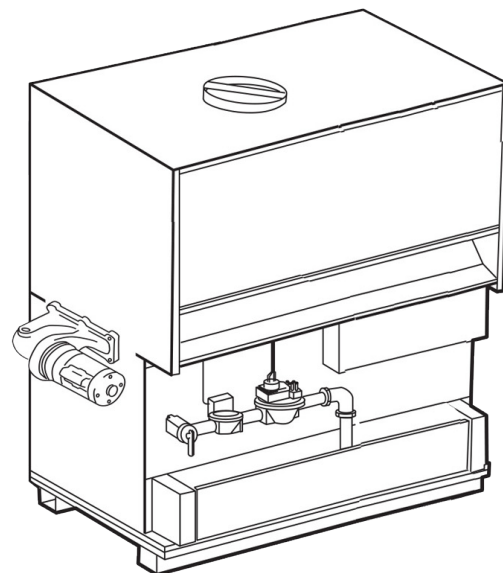

Indoor

SECTION 1. General Information

⚠ IMPORTANT WARNING:

The Model MT commercial pool boilers must be used with potable water only. For pools containing salt water, a specially equipped boiler must be used. Consult your distributor or factory representative. The pool boiler must be installed in accordance with the procedures in this manual, or the warranty could be voided. Consult local building codes and ANSI bulletin Z223.1 or in Canada CAN1-B149 before proceeding with the installation. Any modification to the boiler, its gas controls, gas orifices, wiring or draft diverter may void the Pentair warranty. Consult the factory before making any modifications.

1A. Introduction

This manual provides information for the installation and operation of Pentair Model MT Pool Boilers. It is strongly recommended that all application and installation procedures be reviewed completely before proceeding with the installation. Consult the Pentair factory, or local factory representative, with any problems or questions regarding this equipment. Experience has shown that most operating problems are caused by improper installation.

Series MT boilers are offered in two configurations: an indoor version and an outdoor version. The two configurations are shown on the facing page. The indoor version is convertible for outdoor use with the installation of a conversion kit as described in Section 6 of this manual. Outdoor models are not available in Canada.

Corporate Offices

North Carolina

➔ 1620 Hawkins Avenue
Sanford, NC 27330
Tel: 800-831-7133
Fax: 800-284-4151

California

➔ 10951 W. Los Angeles Avenue
Moorpark, CA 93021
Tel: 800-831-7133
Fax: 800-284-4151

Some accessory items are shipped in separate packages. Verify receipt of all packages listed on the packing slip. Inspect everything for damage immediately upon delivery, and advise the carrier of any shortages or damage. Any such claims should be filed with the carrier. The carrier, not the shipper, is responsible for shortages and damage to the shipment whether visible or concealed.

1.B Heater Identification

Consult the rating plate on the heating boiler. Shown below is a breakdown of the model nomenclature.

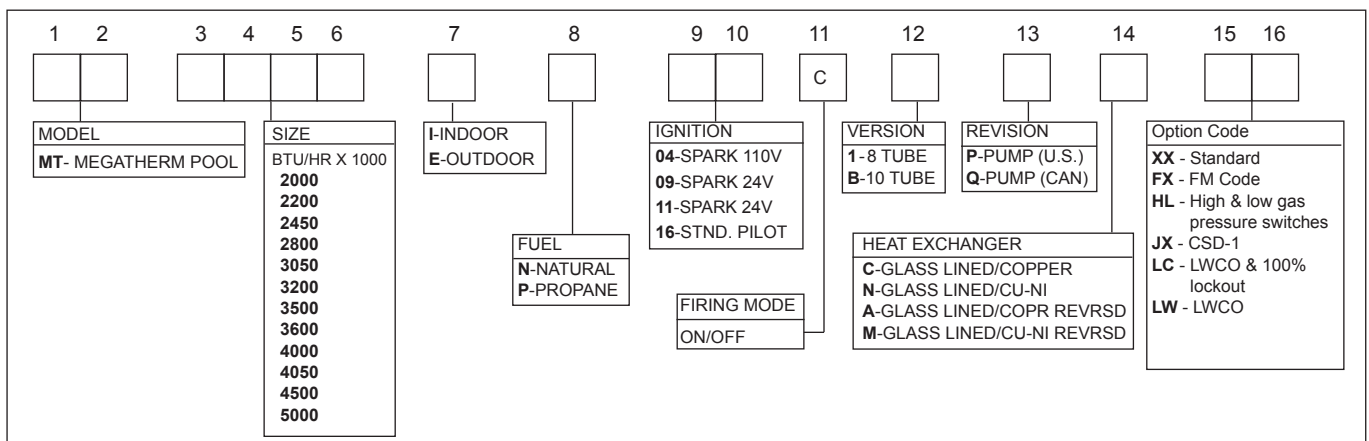

Figure 1. Heater Identification (model nomenclature).

SECTION 2. Installation

2A. Boiler Placement

The boiler must be placed to provide clearances on all sides for maintenance and inspection. There must also be minimum distances maintained from combustible surfaces.

All boilers must be installed on a non-combustible floor. Under no circumstances can boilers be installed on carpeting.

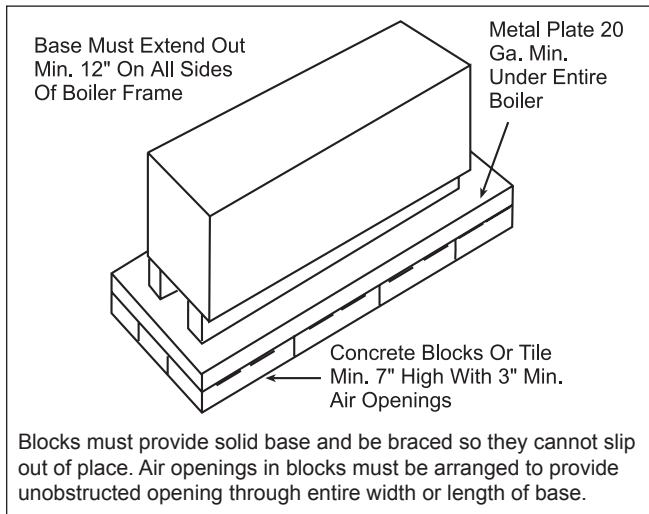

Figure 2. Non-Combustible Base.

The National Fuel Code allows a boiler to be placed on other than a non combustible surface when such an installation complies with the local codes. This code specifies the surface under the boiler be protected with hollow masonry no less than 4" thick, covered with sheet metal at least 20 gage in thickness. Such masonry must be laid with ends unsealed, and joints matched in such a way as to provide a free circulation of air from side to side through the masonry (see Figure 2).

2B. Installation of Indoor Boilers 2B-1. Combustion Air Supply

1. The boiler location must provide sufficient air supply for proper combustion, and ventilation of the surrounding area as outlined in the latest edition of ANSI standard Z223.1 or, in Canada CAN1-B149, and any local codes that may be applicable. Inadequate combustion air supply may result in incomplete combustion and consequent sooting of the heat exchange and unsafe operation of the boiler.
2. In general, (in the U.S.), these requirements specify that equipment rooms which represent confined spaces should be provided with two permanent air supply openings communicating directly through the wall to outside air; one within 12 inches of the ceiling, the other within

Clearance From	Indoor (Inches)	Outdoor (Inches)
Top	24	—
Water Conn. Side	24	24
Opposite Side	24	24
Front	48	48
Rear	24	24
Vent	6	—

Table 1. Minimum Boiler Clearance From Combustible Surfaces

12 inches of the floor. Each opening should have a minimum free area of one square inch per 4,000 BTUH input of the total input rating of all appliances in the enclosed area. These requirements differ in Canada. Consult the National Standard of Canada CAN1-B149 for details. See Table 2 for recommended air supply for U.S. models. An improperly ventilated equipment room can get excessively hot and cause accelerated deterioration of controls and electrical components.

3. Exhaust Fans or Vents: Any equipment which exhausts air from the boiler room can deplete

Indoor Size	Each Opening* (Square Inches)
2000	500
2450	613
3050	763
3500	875
4050	1013
4500	1125
5000	1250

Net Free Area in Square Inches*

*Area indicated is for one of two openings: one at floor level and one at the ceiling, so the total net free area would be double the figures indicated. For all other conditions, refer to latest edition of ANSI A223.1.

NOTE: Check with louver manufacturers for Net Free Area of louvers. Correct for screen resistance to the Net Free Area if a screen is installed. Check all local codes applicable to combustion air.

Table 2. Minimum Recommended Air Supply to Equipment Room.

the combustion air supply or reverse the natural draft action of the venting system. This could cause flue products to accumulate in the room. Additional air must be supplied to compensate for such exhaust. The information in Table 2 is not applicable in installations where exhaust fans or blowers of any type are used. Such installations must be designed by qualified engineers.

4. If a blower or fan is used to supply air to the equipment room, the installer should make sure it does not create drafts which could cause nuisance shut-downs of the pilot. If a blower is necessary

to provide adequate combustion air to the boiler, a suitable switch or equivalent must be wired into the boiler control circuit to prevent the boiler from firing unless the blower is operating.

- The boiler must be completely isolated and protected from any source of corrosive chemical fumes such as emitted by trichlorethylene, perchlorethylene, chlorine, etc.

2B-2. Venting

- Pentair boilers have built-in draft diverters for natural draft operation and must not be connected into any portion of a mechanical draft system under positive pressure. The flue outlet must be connected to a clear, unobstructed vent of adequate capacity terminating above the highest point of the building with an approved vent cap. The venting system should be installed according to the latest edition of ANSI Z223.1 (or CAN1-B149) and any local codes having jurisdiction.

IMPORTANT NOTE: Do not use sheet metal screws at the snap lock joints of Type B gas vents.

- Do not weld or fasten the vent pipe to the boiler draft hood. The weight of the stack must not rest on the boiler. The draft hood and top must be easily removable for normal boiler service and inspection.
- Avoid long horizontal runs of the vent pipe, and too many 90 degree elbows, reductions and restrictions. Horizontal runs should have at least a 1/4" rise per foot in the direction of flow. A vent connector shall be supported for the design and weight of the material employed to maintain clearances and prevent physical damage and separation of joints.
- Avoid terminating boiler vents near air conditioning or air supply fans. The fans can pick up exhaust flue products from the boiler and return them inside the building, creating a possible health hazard. A minimum of 4 feet horizontal distance must be maintained from electric meters, gas meters, and relief equipment.
- Avoid terminating boiler vents near air conditioning or air supply fans. The fans can pick up exhaust flue products from the boiler and return them inside the building, creating a possible health hazard. A minimum of 4 feet horizontal distance must be maintained from electric meters, gas meters, and relief equipment.
- Always use double-wall or insulated vent pipe (Type B or equivalent). In cold weather, uninsulated outside vents can chill the rising flue products, blocking the natural draft action of the venting system. This can create a health hazard by spilling flue products into the boiler room.
- Avoid oversize vent piping or extremely long runs of the pipe which may cause excessive cooling and condensation. Rule of Thumb: The total length of the vent, including the connector and any offset, should not exceed 15 feet for every inch of vent diameter. Longer total lengths shown in venting tables are based on maximum

capacity, not condensation factors.

- When the installation of a draft fan is necessary in the venting system to which a Pentair boiler is to be connected, the installation should be engineered by competent personnel following

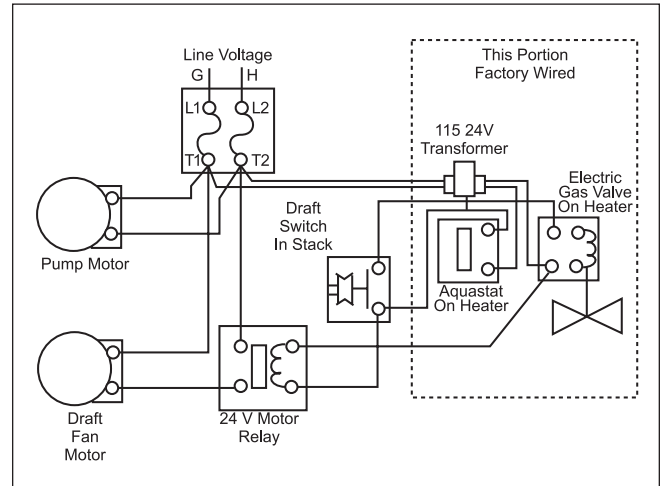

Figure 3. Draft Fan Wiring Diagram.

good engineering practices. The draft fan supplier should be consulted for correct size. The installation should be in accordance with the latest edition of ANSI Z223.1 and any local codes having jurisdiction. When a draft fan is installed, a suitable draft switch must be used and wired into the boiler control circuit at terminal designated "Field Interlock," to prevent firing of the unit unless a positive draft has been established (see Figure 3).

2C. Installation of Outdoor Units

- Locate the boiler to provide the minimum clearances as listed in Section 2A, "Boiler Placement."
- Do not locate the boiler in an enclosure or wall recess. Avoid locations where wind deflection off

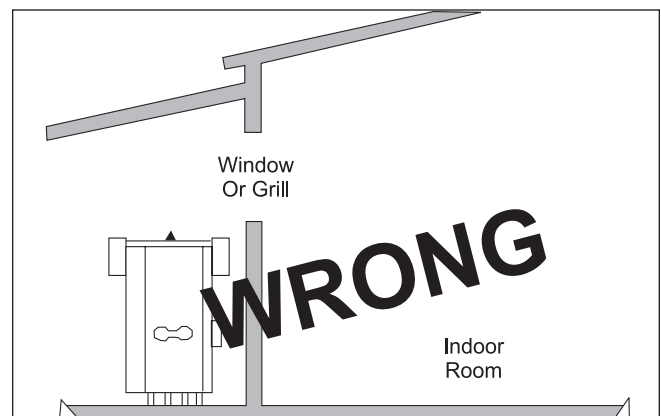

Figure 4. Incorrect Outdoor Installation.

structures might cause down draft. When such wind conditions are possible, locate the unit at least three (3) feet from the structures.

3. Never install the boiler under any kind of roof overhang. Do not locate the unit below or adjacent to any doors, windows, louvers, grills, etc. which communicate in any way with an inhabited area of a building. Even though such communication might be through another structure such as a garage or utility room (see Figure 4).
4. Liquified petroleum is heavier than air. Therefore, the pool boiler should not be installed in pits or other locations where gas could accumulate. The boiler should be located a safe distance from LP gas storage and filling equipment. Consult local codes and fire protection authorities for advice relative to specific installation restrictions.

2D. Freeze Protection

Boiler installations are not recommended in areas where the danger of freezing exists unless proper precautions are made for freeze protection.

2E. Gas Supply and Piping

Review the following instructions before proceeding with the installation.

		Distance from Gas Meter or Natural and LP Gas					
Indoor Size	Outdoor Size	0-100'		100-200'		200-300'	
		Nat.	LP	Nat.	LP	Nat.	LP
2000	—	2½	2	3	2½	3	3
2450	2200	3	2½	3	2½	3½	3
3050	2800	3	2½	3½	3	3½	3
3500	3200	3	2½	3½	3	4	3½
4050	3600	3½	3	4	3½	4	3½
4500	4000	3½	3	4	3½	5	4
5000	4500	4	3½	4	3½	5	4

NOTES:
 These figures are based on ½" water column pressure drop. Check supply pressure and local code requirements before proceeding with work.
 Pipe fittings must be considered when determining gas pipe sizing.

1. Verify that the boiler is fitted for the proper type of gas by checking the rating plate. Pentair boilers are normally equipped to operate below a 2000 foot altitude. Boilers equipped to operate at higher altitudes have appropriate stickers or tags attached.
2. Use the figures in Table 3 to provide adequate gas piping (check local code for BTU capacity

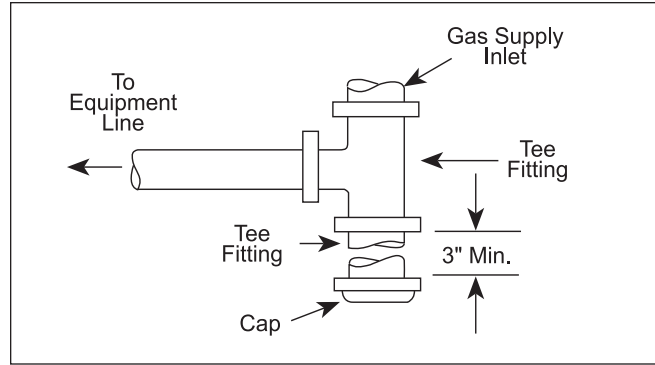

Figure 5. Tee Fitting Sediment Trap.

required).

3. A trap (drip leg) must be provided ahead of the gas controls (see Figure 5). Where required by code, provide a second manual gas shutoff valve. Do not remove manual valve furnished with the unit.
4. The boiler and its individual shutoff valve must be disconnected from the gas supply piping system during any pressure testing of that system at test pressures in excess of 1/2 psig. The boiler must be isolated from the gas supply piping system by closing its individual manual gas shutoff valve during any pressure testing of the gas supply piping system at test pressures equal to or less than 1/2 psig.
5. Provide gas supply pressure to the boiler as follows:

	Natural	Propane
Min. (inches water column)	7	11
Max. (inches water column)	9	14

Note: The boiler and all other gas appliances sharing the gas supply line must be firing at maximum capacity to properly measure the inlet supply pressure. Low gas pressure could be an indication of an undersized gas meter and/or obstructed gas supply line.

6. The correct burner manifold gas pressure is stamped on the rating plate. The regulator is preset at the factory, and normally requires no further adjustment.
7. The gas manifold and control assembly was tested and conforms to the safe lighting and other performance criteria specified in the latest editions of ANSI Z21.13 and CGA 3.3 Low Pressure Boiler Standard.
8. Before operating the boiler, the complete gas supply system and all connections must be tested for leaks using a soap solution. Do not use raw flame.

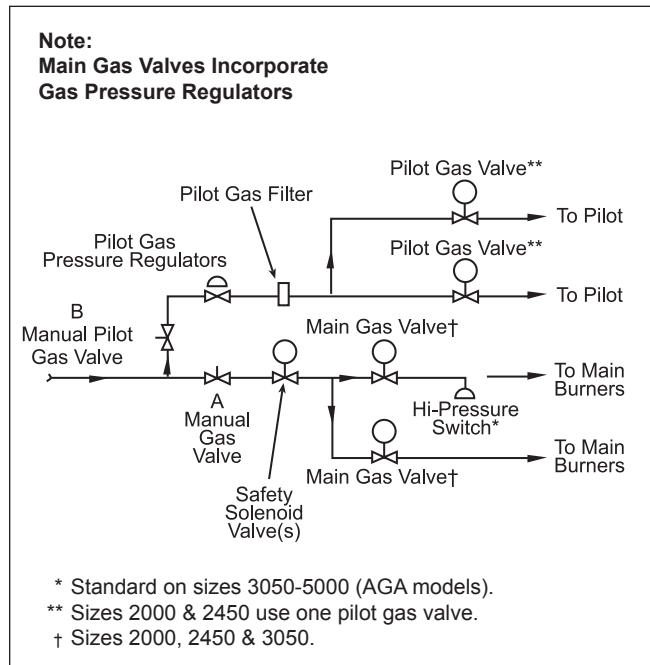

Figure 6. Gas Piping Diagram.

⚠ Caution

Since some leak test solutions, including soap and water, may cause corrosion or stress cracking, the piping must be rinsed with water after testing, unless it has been determined that the leak test solution is noncorrosive.

Arrangement of gas train components for on-off firing are shown schematically in the Gas Piping Diagram (see Figure 6).

2F. Electrical Wiring

⚠ WARNING

The boiler must be electrically grounded in accordance with the most recent edition of the National Electrical Code, ANSI/NFPA 70, and in Canada, follow Canadian Electrical Code CSA C22.1. Do not rely on the gas or water piping to ground the metal parts of the boiler. Frequently, plastic pipe or dielectric unions isolate the boiler electrically. Service and maintenance personnel who work on or around the unit may be standing on wet floors and could be electrocuted by a poorly grounded boiler.

1. Check boiler wiring and pump for correct volt age, frequency and phase. If the pump circuit is other than 115V, check to see that the boiler is provided with an appropriate transformer.

2. Wire the boiler and pump exactly as shown in the wiring diagram supplied with the boiler.
3. The pump and boiler must be electrically interlocked so the boiler cannot come on unless the pump is running.
4. All field installed electrical safety devices and all field installed devices (draft switches, relays, timers, etc.) can be connected to the boiler wiring at points shown in the wiring diagram designated "Field Interlock."
5. Auxiliary Time Clock Wiring. If a time clock is used to control the filter pump operation, a separate switch must be used to shut off the boiler at least 15 minutes before the filter pump is shut off. Wire the separate switch (sometimes called a "Fireman Switch") at the points shown on the internal wiring diagram as "Field Interlock."

2G. Piping of System to Boiler

1. Be sure to provide gate valves at the inlet and outlet to the boiler so it can be readily isolated for service.
2. The pressure relief valve must be installed in the tapped opening provided, or on a "Tee" fitting when provided, in the boiler outlet header with its outlet piped to a drain or floor sink. Special attention must be given to relief valve settings in installations where the boiler is located on the ground floor of a tall building. The static pressure of the system is elevated, and could cause the relief valve to leak. Where no special setting of the relief valve is ordered, the factory will furnish a 75 psi setting. Never reduce the relief valve opening. If necessary, install the relief valve in a Tee immediately past the boiler outlet. The weight of all water and gas piping should be supported by suitable hangers or floor stands. Check piping diagrams with local applicable plumbing, heating and building safety codes.

2H. General Water Piping

1. Plastic fittings, grids, or other elements of the filter system are subject to damage by the momentary "back syphoning" of hot water when the pump stops. To prevent this backflow, install a swinging gate check valve in the piping between the filter and the boiler.
2. No Hartford Loop is required for anti-syphon protection.
3. No water flow adjustments are required except when a manual bypass valve is installed.
4. Do not install any valve or other variable

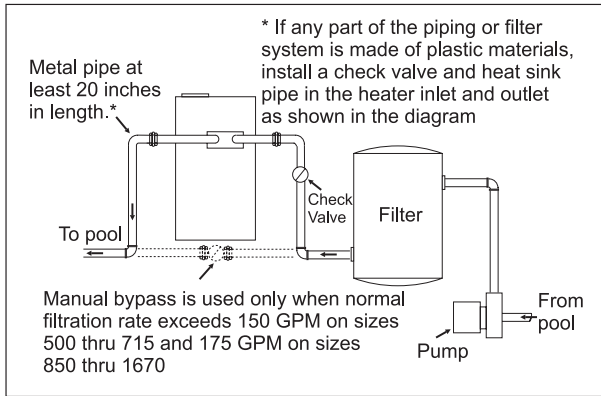

Figure 7. Manual By-Pass Installation.

restriction in the return piping between the boiler outlet and the pool.

5. The outlet pipe is carrying a large volume of water which has bypassed the boiler combined with a small volume of very hot water. Therefore, the temperature difference between the inlet and out pipes will be so small as to be difficult to sense by touching the two pipes.

2 I. Boiler By-Pass Piping

All Model MT pool boilers are equipped with an automatic flow control valve. Do not install a manual bypass valve unless the normal filtration rate exceeds 300 GPM. If the normal filtration rate exceeds that figure:

1. Install the manual bypass valve as illustrated in Figure 7.
2. Install a thermometer in the threaded opening in the rear header as shown in Figure 8.
3. Set the manual bypass valve as follows:
 - a. Clean or backwash the filter completely.
 - b. Close the manual bypass valve completely.
 - c. Close the boiler's main gas valve.
 - d. Start the filtration system with all valves set for normal filtration.
 - e. After 3 minutes, record the thermometer reading at the rear header (this is the pool water temperature).
 - f. Open main gas valve and turn the thermostat to its highest setting to start the boiler.
 - g. Gradually open the bypass valve until the temperature difference shown in column 6 of Table 4 is achieved. For example, if the temperature reading in Step "e" was 60 degrees, and the boiler is a Model 3500, the thermometer should read 75 degrees. Make sure this temperature difference remains constant for at least 5 minutes.

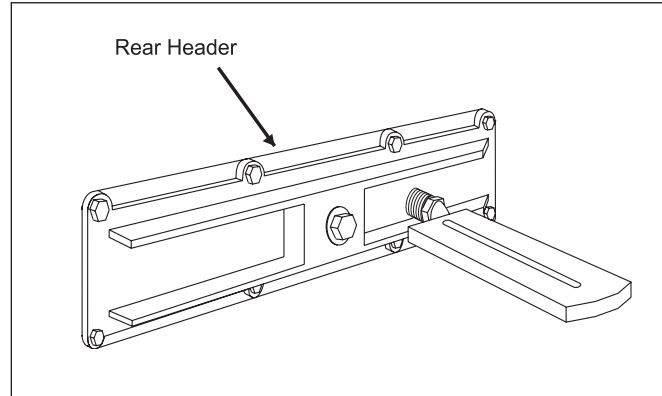

Figure 8. Thermometer Location.

Indoor Size	Outdoor Size	Part No.	Bypass Spring Color Code	Min. Flow Req'd (GPM)Cap.	Max. Bypass Valve (GPM)	Temp. Rise at Rear Header
2000	-----	S220	Black	110	300	15
2450	2200	S221	White	134	300	15
3050	2800	S221	White	167	300	15
3500	3200	S222	Brown	191	300	15
4050	3600	S222	Brown	221	300	15
4500	4000	S222	Brown	246	300	15
5000	4500	S222	Brown	273	300	15

Table 4. By-Pass Valve Adjustments.

- h. Remove the handle from the bypass valve to prevent anyone from changing the setting. The automatic flow control valve will maintain proper flow through the boiler regardless of the reduced water flow due to a dirty or clogged filter.

2J. Automatic Chlorinators

A concentration of chlorine in the boiler can be very destructive. Therefore, the following rules regarding the installation and operation of automatic chlorinators must be followed.

1. The chlorinator should be installed so that it introduces the gas or solution downstream from the boiler.
2. The chlorinator should be wired so that it cannot operate unless the filter pumps running.
3. The chlorinator should be provided with an anti-siphoning device so that when the pump shuts off, chlorine will not syphon back into the boiler.
4. When the chlorinator is installed in the system where the chlorine flows through the boiler, corrosion can occur. Excessive concentrations of chlorine, caused by improper adjustment or failure of the chlorination equipment, can cause boiler damage which is not covered by the warranty.

2K. Pressure Switch

The pressure switch on the boiler is factory set at 4 psi. Do not tamper with the switch unless the boiler is installed more than 3 feet below the surface of the pool. If this condition exists, follow this procedure to adjust the switch:

1. With the boiler on, the filter pump running and the filter clean, slowly increase the pressure setting until the boiler shuts off. Slowly decrease the pressure setting until the boiler comes back on. Decrease the pressure setting another 2 psi to complete the switch setting.
2. Test the setting by closing the manual gas valve and turning off the filter pump. Turn the thermostat to the high setting and slowly open the manual gas valve. The boiler should not try to fire when the filter pump is off.

If the boiler is installed more than three feet above the pool level, install an eyeball fitting on the end of the return line to the pool to create adequate back pressure that the boiler to operate the pressure flow safety switch. Never reduce the factory setting of the pressure switch. For special installation problems, consult the factory.

SECTION 3. Operation

3A. Initial Start-Up

3A-1. Initial Filter Cycle on a New Pool

On a newly constructed pool, be sure to run the filter pump long enough to completely "turn-over" the pool water before turning on the boiler. This will insure that any dirt and residue from the construction will be removed. The filter may clog rapidly during this period, causing the boiler to severely cycle if it is on.

3A-2. Starting Instructions

1. Check the following installation details before proceeding:
 - a. Has the required air supply been provided?
 - b. Is the boiler properly vented?
2. Be sure the filter is clean.
3. Start the filter pump.

Before placing the boiler in operation, the automatic safety shutoff devices must be checked. Once the unit is connected to the gas piping and after all of the requirements in Section 2 have been met, follow this procedure:

 - a. Before beginning the tests, make sure the main

manual gas valve, and any other firing valves are in the OFF position.

- b. Make sure the power switch on the boiler is in the "ON" position. After placing the manual pilot valves in the open position, and resetting all safety devices (high limit, pressure switch, Low-Water-Cutoff, etc.), pilots can be lit following the procedure located on the boiler rating plate.
- c. Once the pilots are lit and have been established for five minutes, the flame failure response time should be checked as follows:

System 16: (Electronically supervised standing pilot system standard on propane gas). Extinguish the pilot flame by placing the manual pilot valve in the closed position, and, at the same time, begin recording the time it takes for the output signal from the electronic ignition control to be interrupted. Refer to the electrical drawing supplied with the boiler for wiring details. The signal interruption can be detected either with a test light or a voltmeter. Because the ignition controls are in series, the control just upstream of the gas valves should be tested first. Under no circumstances should the response time exceed 5 seconds.

System 18: (Intermittent ignition supplied only for natural gas). With this system, pilots are automatically lit when the thermostat calls for heat. The pilots are permitted a trial period for ignition, then the system is locked out if it fails to light. To retry ignition, power to the boiler must be momentarily interrupted. After the pilot is initially lit, the trial for ignition time should be checked by turning off pilot gas, and, at the same time, monitoring the time it takes for the audible sparking at the pilot burner to stop. Under no circumstances should the trial for ignition exceed 15 seconds because electronic ignition controls are in series. The control just upstream of the gas valves should be tested first (refer to the electrical drawing supplied with the unit). Once the trial for ignition period has been checked, the controls should be reset and the flame failure response time checked by following the procedure given for system 16.

4. With the pilots lit, initial activation of the main burners can be achieved by slowly opening the main manual valve. The result should be a smooth lighting of the main burners.

3A-3. Hi-Limit Checkout

After running the boiler for a long enough period to bring the water temperature within the range of the hi-limit, slowly back off the high limit setting until the unit shuts off. The main burners should re-ignite when the hi-limit is turned back up to its original setting.

The high limit should now be reset and the boiler run until it shuts off automatically on high limit.

Now that all tests of the safety shutoff devices have been completed, refer to Section 3B for the proper settings of temperature controls.

NOTE: Should any of the controls fail to function properly, consult the factory or your gas company representative.

3B. To Start Up System (See Section 3A for Initial Start Up)

Start up boiler:

1. Be certain system pump is running.
2. Lighting instructions are provided on the rating plate and in the User's Manual and are as follows:
 - a. Turn off main electrical switch.
 - b. Turn off all manual gas valves and wait five minutes.
 - c. Set aquastat or thermostat to lowest setting.
 - d. Turn manual pilot valve to "ON." For standing pilot system, press on pilot relay knob, light pilot and keep relay knob depressed for one minute then release. Once the pilot is lit, the power will be supplied to the gas valve(s) upon activation of the aquastat.
 - e. Slowly turn manual gas valve to "ON."
 - f. Reset all safety switches (manual reset high limit, low water cutoff, etc.).
 - g. Turn on main electric switch.
 - h. Set temperature controller (aquastat) to desired temperature. Pilot will light automatically (intermittent ignition pilot system) and ignite main burners whenever the aquastat calls for heat.
 - i. Adjust the pool aquastat as follows:

When the pool water has reached the desired temperature, as measured with an accurate thermometer, decrease the aquastat setting with a small screwdriver until the boiler shuts off. The pool boiler will maintain the existing pool water temperature automatically.

3C. To Turn Off Boiler

1. Turn off main electrical switch.
2. Close all manual gas valves.

3D. Spring and Fall Operation

When the pool is not going to be used for a long period of time, turn the aquastat down to approximately 70° F. This will prevent the pool and surrounding ground from becoming chilled, save on fuel costs, and also permit the pool water temperature to be raised back to swimming temperature in a shorter period of time.

The pool water temperature should not be maintained below 70° F. Colder water will cause condensation to form on the heat exchanger when the boiler does fire. Prolonged operation at a lower temperature will cause the boiler to foul externally. See "Improper Use of Boiler."

3E. Winter Operation

To shut down the boiler for longer periods, turn both the manual gas valve and pilot gas valve to OFF. Where the danger of freezing does not exist, the normal filter cycle should be continued all year long to circulate water through the system even when the boiler is turned off or shut down completely.

3E-1. Draining Boiler Before Freezing

If the boiler is located where it will be exposed to freezing temperatures, it should be drained before the first frost. Drain the boiler by removing the drain plug on the bottom of the front header casting. Leave the plug out until time to use the boiler again. The boiler must be level for proper drainage. If compressed air is used to blow out the lines, it is still necessary to follow the same procedure. Keeping the pool heated by continuously running the boiler may not be adequate protection due to the possibility of a pump or power failure.

3E-2. Improper Use of the Boiler

The Pentair MT pool boiler is not designed for continuous use as an anti freezing device for pools.

Operating the boiler at water temperatures below 70° F will cause the heat exchanger fins to be partially blocked with condensation, resulting in incomplete combustion. Prolonged operation under these conditions will result in sooting of the heat exchanger which can seriously damage the boiler and cause a fire hazard.

3F. Time Clock Operation

During the initial warm-up period, the boiler must run continuously. Therefore, remove all time clock stops until the pool water reaches a temperature of at least 70° F.

When resetting the time clocks, be sure to allow the filter pump and boiler enough time to maintain the pool water at the desired temperature.

3G. Spa (Hot Tub) Safety Rules

Therapeutic pools, or “spa” pools, are usually piped and controlled so that very warm or hot water, often with air injection, is forced at high velocity into a confined area of a swimming pool or into a small, separate pool. Both the energy of the water and the heat furnish certain hydrotherapeutic benefits. These pools are excellent for relaxation, body-conditioning, and for arthritic and rheumatic problems, but can be hazardous. The Consumer Product Safety Commission has recommended the following “Safety Rules for Hot Tubs.”

1. Spa or hot tub water temperature should never exceed 104° F (40° C). A temperature of 100° F (38° C) is considered safe for a healthy adult. Special caution is suggested for young children.
2. Drinking of alcoholic beverages before or during spa or hot tub use can cause drowsiness which could lead to unconsciousness and subsequently result in drowning.
3. Pregnant women beware! Soaking in water above 102° F (39° C) can cause fetal damage during the first three months of pregnancy (resulting in the birth of a brain-damaged or deformed child). Pregnant women should stick to the 100° F (38° C) maximum rule.
4. Before entering the spa or hot tub, users should check the water temperature with an accurate thermometer; spa or hot tub thermostats may err in regulating water temperatures by as much as 4° F (2.2° C).
5. Persons with medical history of heart disease, circulatory problems, diabetes or blood pressure problems, diabetes or blood pressure problems should obtain their physician’s advice before using spas or hot tubs.
6. Persons taking medications which induce drowsiness, such as tranquilizers, antihistamines or anticoagulants, should not use spas or hot tubs.

3H. Periodic Service

Inspect the heat exchanger tubes of the Model MT pool boiler on a regular basis. In most areas and under most operating conditions, the MT pool boiler

will operate for years without accumulating any scale in the tubes. However, in some pools the mineral content of the water is such that completely scale-free operation is impossible. For this reason, the MT boiler was designed so that all of the internal wet surfaces can be easily inspected and, if necessary, cleaned. Simple cleaning tools are available from your dealer or the factory.

In order to establish a proper inspection schedule, the tubes should be inspected after the first sixty days of operation, and again after 120 days. From the appearance of the tubes, it will be possible to determine the best regular inspection schedule.

When pool equipment is located outdoors, a certain amount of dust and moisture can infiltrate the mechanical parts of the controls. After many years, this could cause deterioration. A regular service schedule will insure longer life and safe operation of the equipment.

3 I. Pool Water Chemistry

Due to natural evaporation, which only removes the water and leaves the minerals, the mineral content of pool water increases daily. Also, the regular addition of algaecidal and sanitizing chemicals substantially adds to the mineral content of the pool. If the mineral content of the pool is allowed to get too high, the minerals will precipitate out of the water and deposit on the walls of the pool, the filter, and the heat exchanger tubes. For this reason, it is important that the pool be completely drained regularly (at least every two years) to reduce the chance of expensive repairs to the pool, filter system and boiler.

It is also important to maintain the pH level of the pool water between 7.3 and 7.7 which can add years to the life of the pool finish, filter system and boiler.

Most algaecidal and sanitizing chemicals contain sodium hypochlorite, while others contain calcium hypochlorite. Sodium is not a scaling chemical, but calcium definitely is. So when chemicals are used which contain calcium, it is even more critical that the pH level of the pool water be maintained properly, and that the pool water be completely changed when the dissolved solids indicate an excessive mineral content.

SECTION 4. Maintenance

- At start-up and every six (6) months thereafter, the pilot and main burner flame should be observed for proper performance (see Figures 9 and 10; see attached lighting and shutdown instructions for proper pilot flame pattern). If flame has the appearance of “sooting” tips, check for debris near orifices. Call service technician.

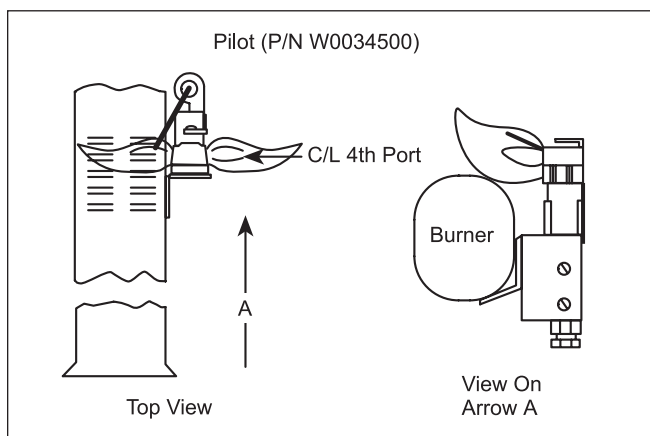

Figure 9. Pilot Location.

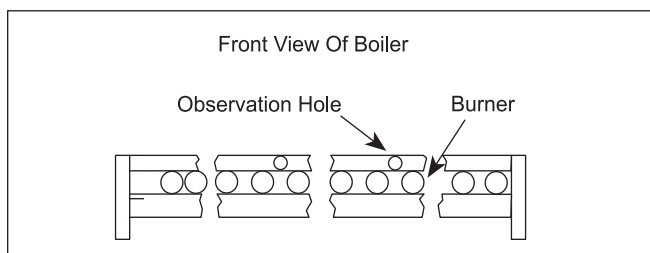

Figure 10. Periodic Flame Observation.

- Inspect the venting system for obstruction, leakage, and corrosion at least once a year.
- Keep boiler area clear and free from combustible material, gasoline and other flammable liquids and vapors. Boiler surfaces are hot and could ignite combustible materials.
- Be certain all combustion air and ventilation openings are unobstructed.
- Check for fouling on the external surfaces of the heat exchanger every six months.

NOTE: After installation and first start-up, check the heat exchanger for fouling after the following periods of operation: 24 hours, 7 days, 30 days, 90 days, and once every six months thereafter.

Fouling on the external surfaces of the heat exchanger is caused by incomplete combustion, and is a sign of combustion air and/or venting problems. As soon as any fouling is observed, the cause of the fouling should be corrected (see Section 5 Troubleshooting). The heat exchanger can be checked

with a flashlight by locating a mirror under the burners. An alternate method is to remove the venting and top panel as necessary to inspect from above. Also, check the vent system for defects at the same time.

- If cleaning is required, shut off all electrical and gas supply to the boiler.
- To expose the heat exchanger:
Remove top panel covers located at the base of the front and rear flue collector panels. Remove all but the top screws on each side of the front and rear flue collector panels. The panels can be swung outward and propped up to reveal the heat exchanger. Remove all heat exchanger baffles.
- Remove all burners:

Caution

Black carbon or green soot on a dirty heat exchanger can, under certain conditions, be ignited by a random spark or open flame. To prevent this unlikely occurrence, dampen the soot deposits with a wet brush or fine water spray before servicing or cleaning the heat exchanger.

With a wire brush, remove soot and loose scale from the heat exchanger. Do not use water or compressed air for cleaning. Clean fallen debris from the bottom of the boiler. Check that burner ports are clear and pilot assembly is free of debris.

- Reassemble in reverse order:
Be sure to replace the heat exchanger baffles.
- The gas and electric controls installed on the boilers are designed for both dependable operation and long life. But the safety of this equipment depends completely on their proper functioning. It is strongly recommended that the basic items be checked by a competent service technician every year, and replaced when necessary. The basic controls are:
 - Water temperature controls.
 - Pilot safety system.
 - Automatic electric gas valve(s).
 - Water pressure switch.
 - Flow sensing safety device (when used).
 - Low water cutoffs should be inspected every six (6) months, including flushing or float types.

NOTE: Warranty does not cover any damage caused by lack of required maintenance or improper operating practices.

SECTION 5. Troubleshooting and Analysis of Service Problems

1. For proper service and problem diagnosis of the boiler and system, the following tools are required:
 - a. Gas pressure test kit with range from zero to 14" W.C. Either a slack tub manometer or an accurate gas pressure gauge is acceptable with proper adaptors which will connect to the available fittings in the line and on the gas valve.
 - b. Electric meter(s) with the following ranges:
0 to 500 volts A.C.
0 to 1000 ohms continuity.
 - c. Millivolt meter with the following ranges:
0 to 50 millivolts. 0 to 500 millivolts.
0 to 1000 millivolts.
 - d. Tube cleaning kit consisting of reamer, stainless steel brush, speed handle and handle extensions.
 - e. Accurate thermometer and pressure gauge.
2. In addition, the boiler should be equipped with a thermometer with proper ranges.

Boiler Will Not Fire	
Possible Cause	What To Do
Electric Power is off.	Check to see that main power switch is ON. Use testing device to trace power to boiler junction box.
Operating or safety control has opened circuit to electric gas valve.	Turn off power. Use continuity tester to check continuity across terminals of each operating and safety control switch up to the electric gas valve. Replace defective control.
Pilot flame is out.	Relight pilot per instructions.
Manual reset device has tripped.	Follow instructions for start-up. Reset pilot safety and all manual reset safety switches.
No gas pressure to burners.	Trace gas line to service shutoff cock. If service cock is open, trace gas line to meter. If no pressure is present at meter, call for public utility service. If gas is present in heater inlet, check pressures in following sequence: (1) downstream from pressure regulator, (2) downstream from electric gas valve. Replace or adjust as necessary.
Electric gas valve operator is burned out or shortened.	Disconnect wiring harness at gas valve terminals. Check continuity to actuator coil. If open circuit or short is indicated, replace coil or operator.

Boiler is Pounding, Knocking, or Emitting Steam from Relief Valves	
Possible Cause	What To Do
Lower or no water flow.	This condition is usually caused by lack of adequate water flow through heater. check the following: 1. Is the heater wired into the pump circuit so that the heater cannot fire unless the pump is running? 2. Check to see that all valves in system are open to be sure that water can circulate through the heater and the system. 3. Examine pump for clogged impeller. 4. Check water filter.
Debris from system is blocking tubes.	Remove header covers. Examine all tubes and waterways. Use new gaskets when reassembling. Clean out tubes.
Scale has formed in tubes.	This is always caused by heavy mineral content of the water or clogged filter. Check the water chemistry. Replace the filter and clean all the internal wet surfaces.

Soot in Flueways or in Tubes, or Noxious Fumes Indicative of Bad Combustion	
Possible Cause	What To Do
Combustion air supply to equipment room is inadequate.	Check air supply opening. Look for debris in screen or louvre which covers combustion air opening, or for material blocking the opening.
Stack or vent is blocked or restrictive.	Look for blocked stack and excessive number of elbows in stack or excessive length of horizontal runs.
Severe down draft is causing spillage of flue products into room.	Check for (1) proper vent cap on stack; (2) adequate height of stack above roof; (3) equipment exhausting air from inside of building.
Gas pressure to burners is excessive.	Check gas pressure with manometer, and adjust with heater firing at full rate.
Heater not fitted for the fuel being supplied.	See nameplate for correct fuel.
Heater installed at high altitude without proper derating.	Installations at altitudes in excess of 2000 ft. above sea level are subject to jurisdiction of the local inspection authorities. Check with the factory.

Water Dripping in Firebox	
Possible Cause	What To Do
Tube in heat exchanger has overheated and ruptured.	A tube failure is almost always caused by: (a) Scale formation in the tube, or: (b) inadequate water flow through the boiler. Replace heat exchanger tube(s) and check for proper flow.

SECTION 6.

Conversion of Model MT Pool Boilers From Indoor to Outdoor Models

Please read the following instructions with Figure 11. Figure 12 shows the conversion completed. Please follow the instructions in their numerical order, failure to do this will cause problems on assembly.

6A. SECTION I (See Figure 11)

1. Remove top panel. (1)
2. Remove front and rear upper panels, (2).
3. Remove front and rear wings LH & RH, (3).
4. Remove diverter assembly, (4).
5. Remove outer screw from upper end panel at junction with lower end panel.
6. Remove disconnect all probes and wires going to castings and gas train.
7. Remove control box assembly - front of boiler (not shown).

6B. SECTION II (See Figure 12)

1. Install front LH & RH extension panels (flush with top of upper end panel). (18)
2. Install rear LH & RH extension panels (flush with top of upper end panel). (15) (pick up holes provided into LB upper and lower end panels)
3. Install front bottom panel. (21)
4. Install rear bottom panel. (14)
5. Install front inner baffles (2) 4" from ends. (17)
6. Install rear inner baffle (1) 2" from ends. (16)
7. Install front LH & RH upper spacers. (27)
8. Install rear LH & RH upper spacers. (7)
9. Install front flue collector extension (screw onto flange of lower flue collector only). (28)
10. Install rear flue collector extension (screw onto flange of lower flue collector only). (8)
11. Install rear upper panel and remaining screws from flue collector extension. (12)
12. Install middle rear panel. (13)
13. Install front panel making sure opening for removable panel is square. (19)
14. Install front stiffener (184) 2450 and up.
15. Install remaining screws from flue collector extension.
16. Install rear top half. (panel-5)
17. Install front top half. (panel-6)
18. Install front wire (26) mesh using angle (24) at top and strap (25) at bottom (mesh to be inserted under angles of wind baffle stand offs).
19. Install rear mesh same as Step 18.
20. Install front LH & RH wind baffle stand off. (23)
21. Install rear LH & RH wind baffle stand off. (23)
22. Install front and rear wind baffles. (22)
23. Install middle rear baffle stand off. (11)
24. Install middle rear baffle. (10)
25. Install wires control box parts onto control panel (not shown).
26. Install control panel assembly using holes and bushings provided in RH extension panel for probes and wires (not shown).
27. Install removable panels. (20)

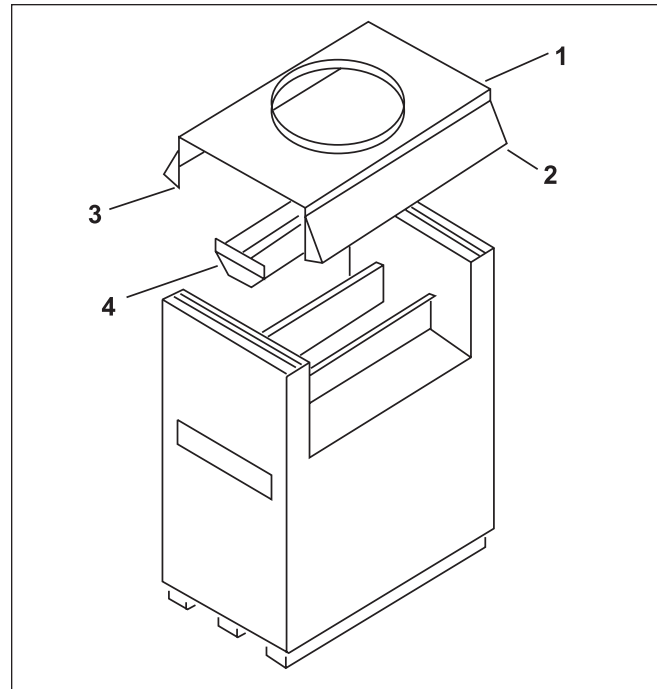

Figure 11. Removal of Indoor Parts.

PARTS LIST FOR CONVERSION KIT - INDOOR TO OUTDOOR (See Figure 12)

Key No.	Part No.
5.....	20017100
6.....	20016900
7.....	20015101
	20015102
8.....	20016700
9.....	20017200
10.....	20017300
11.....	20017700
12.....	20016500
13.....	20016600
14.....	20016300
15.....	20014301
	20014302
16.....	20015200
17A Left Front Baffle (Single Inlet Manifold)	20015300
17B Right Front Baffle (Single Inlet Manifold).....	20022300
17C Left Front Baffle (Split Inlet Manifold).....	20022000
17D Right Front Baffle (Split Inlet Manifold)	20022100
18.....	20014601
	20014602
19.....	20016100
20.....	20018000
21.....	20016200
22.....	20017200
23.....	20017600
24.....	20018200
25.....	20018300
26.....	20018600
27.....	20015001
	20015002
28.....	20016800

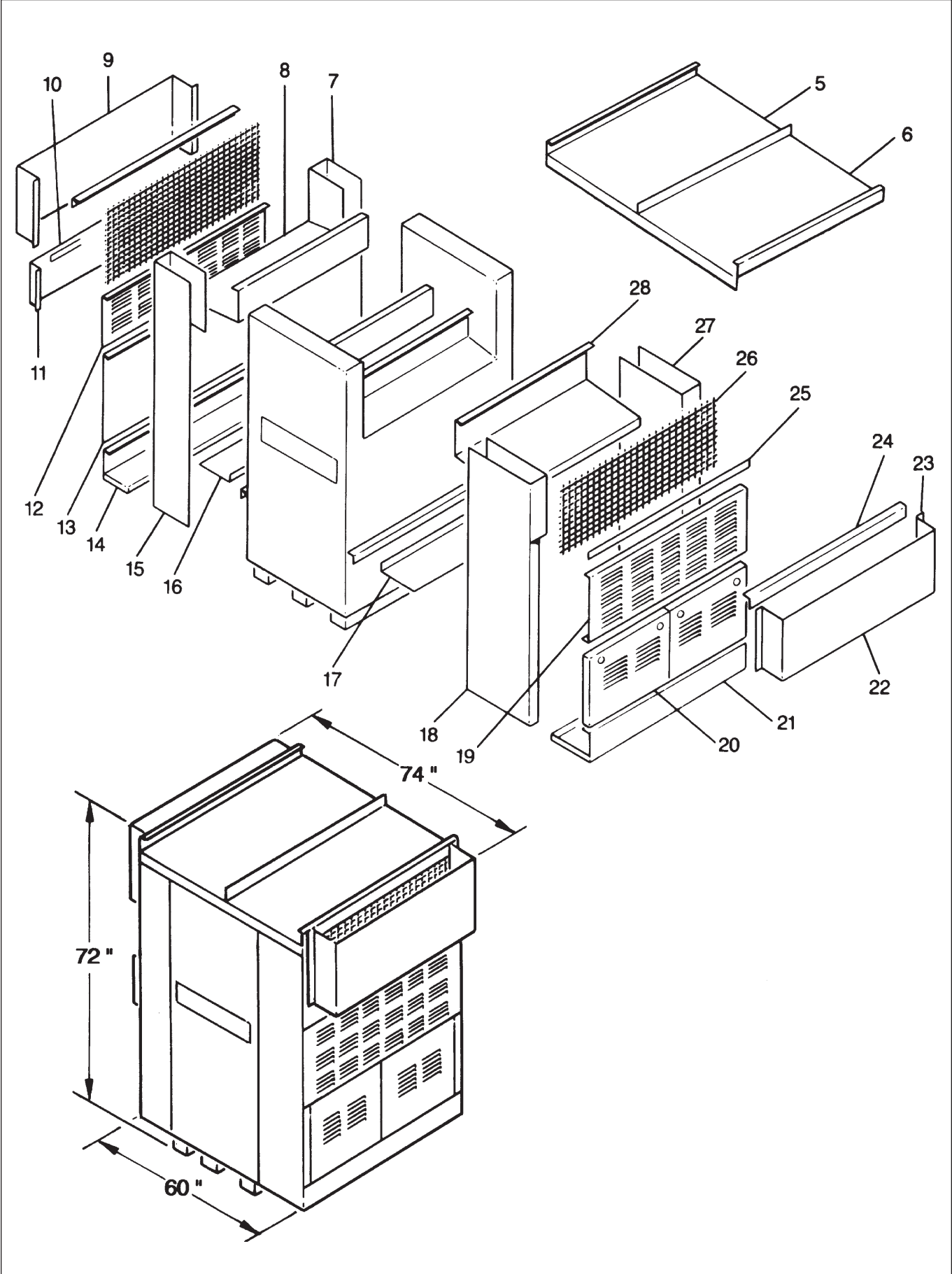

Figure 12. Outdoor Parts. Referenced on page 14.

SECTION 7.

Parts Description and Order Numbers

Key No.	Description	Size 2000 I	Size 2450 I 2200 E	Size 3050 I 2800 E	Size 3500 I 3200 E	Size 4050 I 3600 E	Size 4500 I 4000 E	Size 5000 I 4500 E
1.	Base Weldment Assembly	20067201	20067202	20067203	20067204	20067205	20067206	20067207
2.	Base Assembly	20011001	20011002	20011003	20011004	20011005	20011006	20011007
3.	Center Heat Shield Assembly	20005701	20005702	20005703	20005704	20005705	20005706	20005707
3a.	Center Heat Shield Panel	20005601	20005602	20005603	20005604	20005605	20005606 (2)	20005607 (2)
4.	End Tile Rail Support, Left	20011101	20011101	20011101	20011101	20011101	20011101	20011101
4a.	End Tile Rail Support, Right	20011102	20011102	20011102	20011102	20011102	20011102	20011102
5.	Manifold Assy., Single	20064301	20064201	20064401	20064501	20064600	20064700	20064800
	Manifold Assy., Split	20064302	20064202	20064402	20064502	20064600	20064700	20064800
6a.	Pilot Burner/Bracket Welder	20012600	20012600	20012600 (2)	20012600 (2)	20012600 (2)	20012600 (2)	20012600 (2)
6b.	Main Burner (without pilot bracket)	L2005800 (22)	L2005800 (27)	L2005800 (32)	L2005800 (37)	L2005800 (44)	L2005800 (48)	L2005800 (54)
7.	Inner Shield	20002300 (2)	20002300 (2)	20002300 (2)	20002300 (2)	20002300 (2)	20002300 (2)	20002300 (2)
8.	End Tile Channel	20002600 (2)	20002600 (2)	20002600 (2)	20002600 (2)	20002600 (2)	20002600 (2)	20002600 (2)
9.	Front Lower Closure	20004301	20004302	20004303	20004304	20004305	20004306	20004307
10.	Rear Tile Rail Assembly	20011401	20011402	20011403	20011404	20011405	20011406	20011407
11.	Front Tile Rail Assembly	20011301	20011302	20011303	20011304	20011305	20011306	20011307
12.	Rear Closure Assembly	20012401	20012402	20012403	20012404	20012405	20012406	20012407
13.	Heat Shield Support Bracket	20003201 (2)	20003202 (2)	20003203 (2)	20003204 (2)	20003205 (2)	20003206 (2)	20003207 (2)
14.	Tile Heat Shield Assembly	20012101 (2)	20012102 (2)	20012103 (2)	20012104 (2)	20012105 (2)	20012106 (2)	20012107 (2)
15.	Lower Panel Assembly F & R	20011601 (2)	20011602 (2)	20011603 (2)	20011604 (2)	20011605 (2)	20011606 (2)	20011607 (2)
16.	Tile Cover	20005801 (2)	20005802 (2)	20005803 (2)	20005804 (2)	20005805 (2)	20005806 (2)	20005807 (2)
17.	Saddle Assembly End Tile	10533601 (2)	10533601 (2)	10533601 (2)	10533601 (2)	10533601 (2)	10533601 (2)	10533601 (2)
18-19.	Tile Assembly	See Tile Drawing on Page 17						
20.	Center Support Assembly	20004900	20004900	20004900	20004900	20004900	20004900	20004900
21.	Heat Exchanger Assembly	20001301	20001302	20001303	20001304	20001305	20001306	20001307
21a.	Gasket, Header	S0095300	S0095300	S0095300	S0095300	S0095300	S0095300	S0095300
21b.	Water Barrier	10397500	10397500	10397500	10397500	10397500	10397500	10397500
21c.	Double Pass Header	10416200	10416200	10416200	10416200	10416200	10416200	10416200
21d.	Gasket, Flange	S0095600 (2)	S0095600 (2)	S0095600 (2)	S0095600 (2)	S0095600 (2)	S0095600 (2)	S0095600 (2)
21e.	Flange	10417400 (2)	10417400 (2)	10417400 (2)	10417400 (2)	10417400 (2)	10417400 (2)	10417400 (2)
21f.	Cap Screw-Hex. Hd. ½" - 13UNC x 2"	F0024500 (8)	F0024500 (8)	F0024500 (8)	F0024500 (8)	F0024500 (8)	F0024500 (8)	F0024500 (8)
21g.	Return Header	10416100	10416100	10416100	10416100	10416100	10416100	10416100
21h.	Gasket, Header	S0095300	S0095300	S0095300	S0095300	S0095300	S0095300	S0095300
21j.	Cap Screw-Hex. Hd. ½" - 13UNC x 1½"	F0013300 (36)	F0013300 (36)	F0013300 (36)	F0013300 (36)	F0013300 (36)	F0013300 (36)	F0013300 (36)
21k.	Washer - ½"	F0010300 (36)	F0010300 (36)	F0010300 (36)	F0010300 (36)	F0010300 (36)	F0010300 (36)	F0010300 (36)

I=Indoor, E=Outdoor. Quantity is 1, unless otherwise noted.

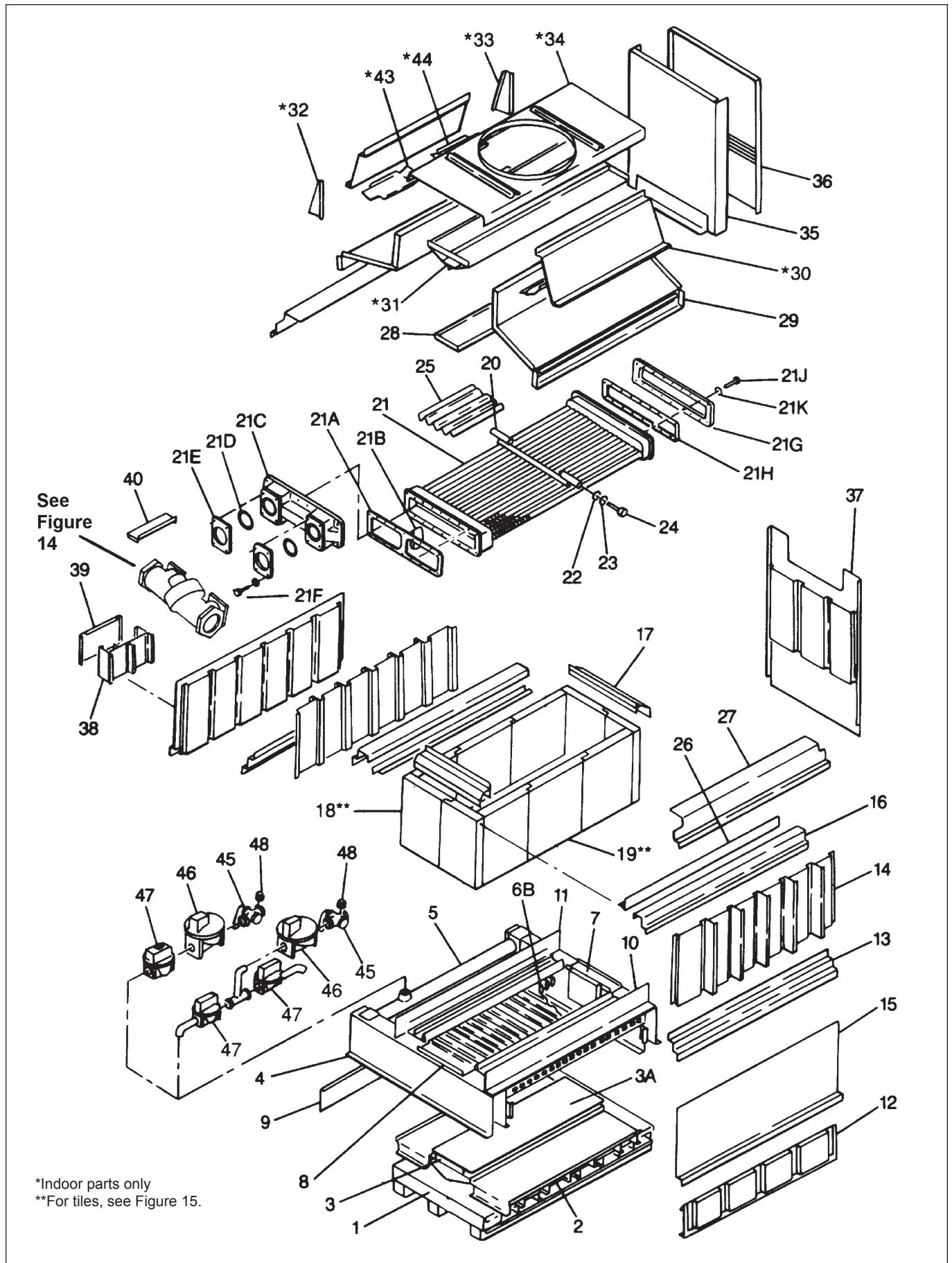

Figure 13. Parts Identification.

Key No.	Description	Size	Size	Size	Size	Size	Size	Size
		2000 I	2450 I 2200 E	3050 I 2800 E	3500 I 3200 E	4050 I 3600 E	4500 I 4000 E	5000 I 4500 E
22.	Lock Washer - $\frac{3}{8}$ "	F0010800 (2)	F0010800 (2)	F0010800 (2)	F0010800 (2)	F0010800 (2)	F0010800 (2)	F0010800 (2)
23.	Washer - $\frac{3}{8}$ "	F0011100 (2)	F0011100 (2)	F0011100 (2)	F0011100 (2)	F0011100 (2)	F0011100 (2)	F0011100 (2)
24.	Cap Screw $\frac{3}{8}$ " - 16UNC x $\frac{3}{4}$ "	F0015900 (2)	F0015900 (2)	F0015900 (2)	F0015900 (2)	F0015900 (2)	F0015900 (2)	F0015900 (2)
25.	Heat Exchanger Baffle Assembly	20010900 (68)	20010900 (68)	20010900 (68)	20010900 (102)	20010900 (102)	20010900 (102)	20010900 (102)
26.	Heat Exchanger Baffle F & R	10534310 (2)	10534311 (2)	10534312 (2)	10534313 (2)	10534314 (2)	10534315 (2)	10534316 (2)
27.	Front & Rear Closure	20006401 (2)	20006402 (2)	20006403 (2)	20006404 (2)	20006405 (2)	20006406 (2)	20006407 (2)
28.	Inside Baffle Assembly	Indoor 20012501 Outdoor N/A	20012502 20012509	20012503 20012510	20012504 20012511	20012505 20012512	20012506 20012513	20012507 20012514
29.	Flue Panel Assembly, F&R	20011501 (2)	20011502 (2)	20011503 (2)	20011504 (2)	20011505 (2)	20011506 (2)	20011507 (2)
30.	Upper Panel F & R (indoor only)	20011701 (2)	20011702 (2)	20011703 (2)	20011704 (2)	20011705 (2)	20011706 (2)	20011707 (2)
31.	Flue Diverter Assembly (indoor only)	20012201	20012202	20012203	20012204	20012205	20012206	20012207
32.	Upper Wing F & R, Left (indoor only)	20006301 (2)	20006301 (2)	20006301 (2)	20006301 (2)	20006301 (2)	20006301 (2)	20006301 (2)
33.	Upper Wing F & R, Right (indoor only)	20006302 (2)	20006302 (2)	20006302 (2)	20006302 (2)	20006302 (2)	20006302 (2)	20006302 (2)
34.	Top Panel Assembly (indoor only)	20012301	20012302	20012303	20012304	20012305	20012306	20012307
35.	Flue End Assembly	20012000 (2)	20012000 (2)	20012000 (2)	20012000 (2)	20012000 (2)	20012000 (2)	20012000 (2)
36.	Upper End Assembly	20011900 (2)	20011900 (2)	20011900 (2)	20011900 (2)	20011900 (2)	20011900 (2)	20011900 (2)
37.	Lower End Panel Assembly	20011800 (2)	20011800 (2)	20011800 (2)	20011800 (2)	20011800 (2)	20011800 (2)	20011800 (2)
38.	Control Mounting Panel	20013700	20013700	20013700	20013700	20013700	20013700	20013700
39.	Control Cover - Front	20018700	20018700	20018700	20018700	20018700	20018700	20018700
40.	Control Box Cover Top	20011200	20011200	20011200	20011200	20011200	20011200	20011200
41.	Pilot Lead Assembly (Johnson) Standing Pilot, Nat/Propane	20035403	20035403	20035403 (2)	20035403 (2)	20035403 (2)	20035403 (2)	20035403 (2)
	Pilot Lead Assembly (Honeywell) Standing Pilot, Nat/Propane	20035404	20035404	20035404 (2)	20035404 (2)	20035404 (2)	20035404 (2)	20035404 (2)
	Pilot Lead Assembly (Johnson) IID Pilot, Nat	20035401	20035401	20035401 (2)	20035401 (2)	20035401 (2)	20035401 (2)	20035401 (2)
	Pilot Lead Assembly (Honeywell) IID Pilot, Nat	20035402	20035402	20035402 (2)	20035402 (2)	20035402 (2)	20035402 (2)	20035402 (2)
42.	Pilot Shield	20016400	20016400	20016400 (2)	20016400 (2)	20016400 (2)	20016400 (2)	20016400 (2)
43.	Draft Hood Relief Baffle - Right (indoor only)	20013801 (2)	20013801 (2)	20013801 (2)	20013801 (2)	20013802 (2)	20013803 (2)	20013804 (2)
44.	Draft Hood Relief Baffle - Right (indoor only)	20013805 (2)	20013805 (2)	20013805 (2)	20013805 (2)	20013806 (2)	20013807 (2)	20013808 (2)
45.	Manual Valve	V0001800	V0001800	V2013800	V2013800	V2013800	V2013900	V2013900
46.	Safety Valve (U.S.)	V0046800	V0046800	V0046900	V0046900	V0046900	V2000500	V2000500
	Lubricated Plug Valve (Canada)	V0020500	V0020500	V0020600	V0020500 (2)	V0020500 (2)	V0020500 (2)	V0020500 (2)
47.	Operating Valve	V0047800	V0047800	V0047900	V0047700 (2)	V0047800 (2)	V0047800 (2)	V0047800 (2)

I=Indoor, E=Outdoor. Quantity is 1, unless otherwise noted.

Key No.	Description	Size 2000 I	Size 2450 I 2200 E	Size 3050 I 2800 E	Size 3500 I 3200 E	Size 4050 I 3600 E	Size 4500 I 4000 E	Size 5000 I 4500 E
48.	Manual Pilot Valve	W0002100	W0002100	W0002100 (2)	W0002100 (2)	W0002100 (2)	W0002100 (2)	W0002100 (2)
49(a).	Pilot Valve (I.I.D.) (not shown)	W0019300	W0019300	W0019300 (2)	W0019300 (2)	W0019300 (2)	W0019300 (2)	W0019300 (2)
49(b).	Pilot Relay (Standing Pilot) (not shown)	W003000	W003000	W003000 (2)	W003000 (2)	W003000 (2)	W003000 (2)	W003000 (2)
50.	Pilot Burner (Johnson) Standing Pilot, Nat	W0034700	W0034700	W0034700 (2)	W0034700 (2)	W0034700 (2)	W0034700 (2)	W0034700 (2)
	Pilot Burner (Honeywell) Standing Pilot, Nat	W0034800	W0034800	W0034800 (2)	W0034800 (2)	W0034800 (2)	W0034800 (2)	W0034800 (2)
51.	Pilot Burner (Johnson) Standing Pilot, Propane	W0034600	W0034600	W0034600 (2)	W0034600 (2)	W0034600 (2)	W0034600 (2)	W0034600 (2)
	Pilot burner (Honeywell) Standing Pilot, Propane	W0034400	W0034400	W0034400 (2)	W0034400 (2)	W0034400 (2)	W0034400 (2)	W0034400 (2)
52.	Pilot Burner (Johnson) IID Pilot, Nat	W0034500	W0034500	W0034500 (2)	W0034500 (2)	W0034500 (2)	W0034500 (2)	W0034500 (2)
	Pilot Burner (Honeywell) IID Pilot, Nat	W0034300	W0034300	W0034300 (2)	W0034300 (2)	W0034300 (2)	W0034300 (2)	W0034300 (2)

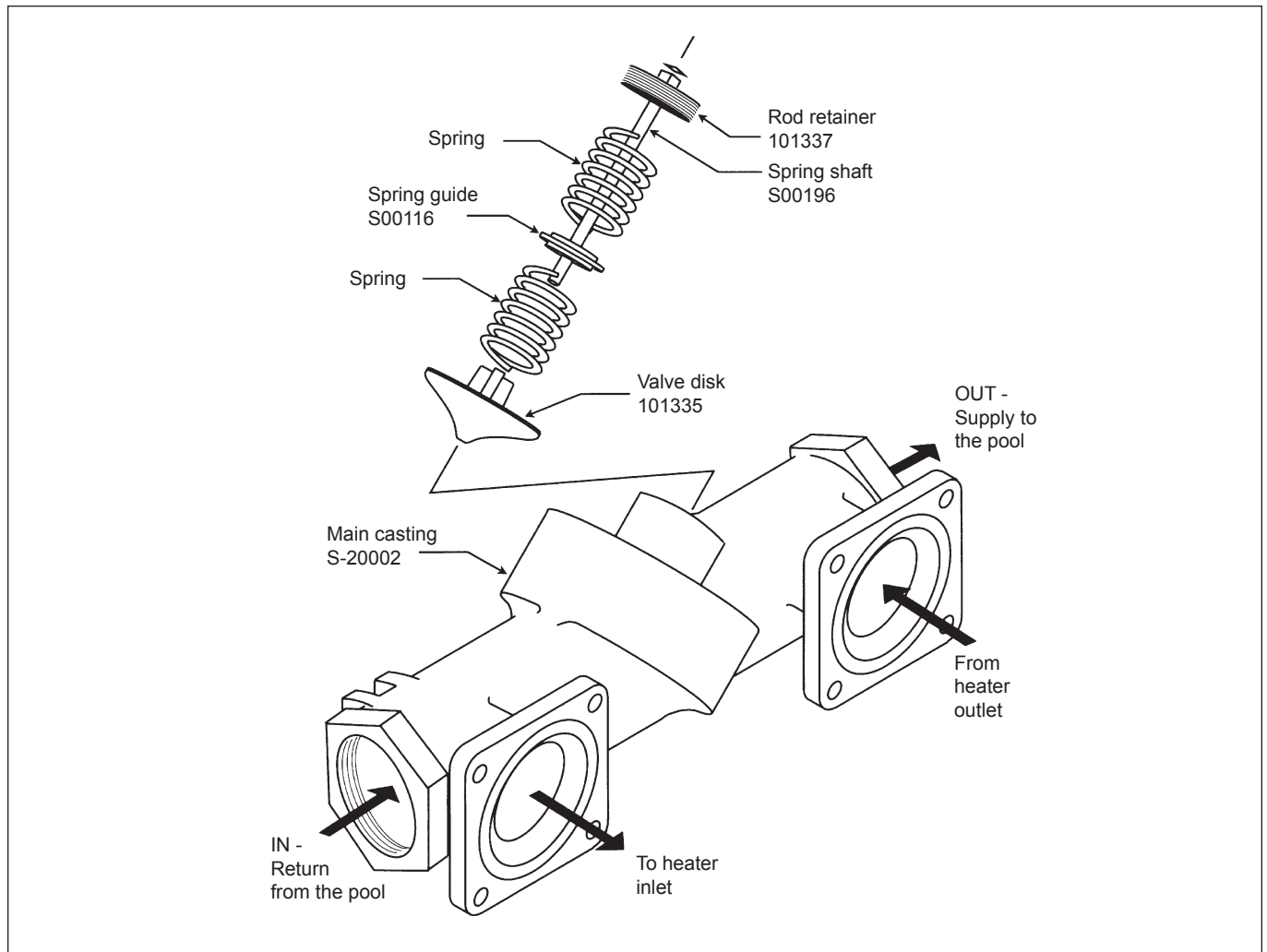

Figure 14. Built-in Automatic Control Valve.

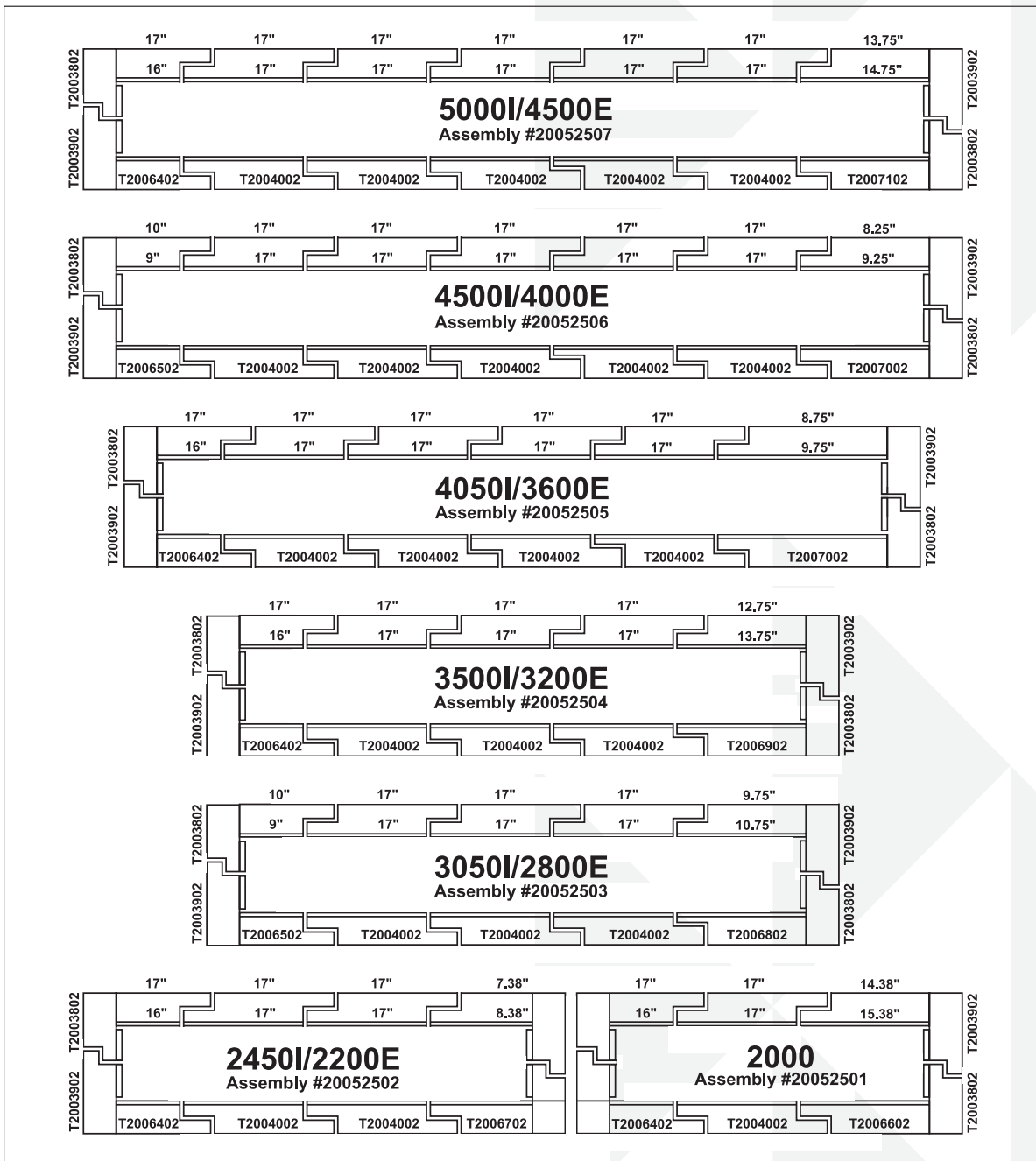

Figure 15. Tile Assembly.



All Pentair trademarks and logos are owned by Pentair or by one of its global affiliates. MegaTherm® is trademarked and/or a registered trademark of Pentair Water Pool and Spa, Inc. and /or its affiliated companies in the United States and/or other countries. Unless expressly noted, names and brands of third parties that may be used in this document are not used to indicate an affiliation or endorsement between the owners of these names and brands and Pentair Water Pool and Spa, Inc. Those names and brands may be the trademarks or registered trademarks of those third parties. Because we are continuously improving our products and services, Pentair reserves the right to change specifications without prior notice. Pentair is an equal opportunity employer.

© 2018 Pentair Water Pool and Spa, Inc. All rights reserved. This document is subject to change without notice.

H2320600B

5500 Wayzata Boulevard, Suite 800, Minneapolis, MN 55416

TECHNICAL SUPPORT: 800.831.7133



P/N 472644 Rev B 02/14/18

