

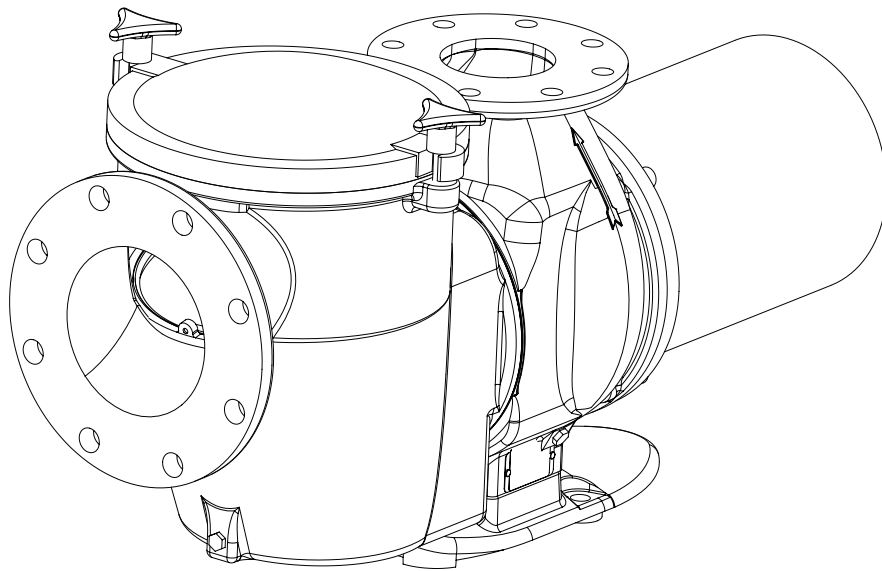

C SERIES®

BRONZE COMMERCIAL PUMP



INSTALLATION GUIDE

IMPORTANT SAFETY INSTRUCTIONS
READ AND FOLLOW ALL INSTRUCTIONS
SAVE THESE INSTRUCTIONS

IMPORTANT PUMP WARNING AND SAFETY INSTRUCTIONS



IMPORTANT NOTICE

This guide provides installation and operation instructions for this pump. Consult Pentair with any questions regarding this equipment.

Attention Installer: This guide contains important information about the installation, operation and safe use of this product. This information should be given to the owner and/or operator of this equipment after installation or left on or near the pump.

Attention User: This manual contains important information that will help you in operating and maintaining this product. Please retain it for future reference.

READ AND FOLLOW ALL INSTRUCTIONS SAVE THESE INSTRUCTIONS



This is the safety alert symbol. When you see this symbol on your system or in this manual, look for one of the following signal words and be alert to the potential for personal injury.

DANGER

Warns about hazards that can cause death, serious personal injury, or major property damage if ignored.

WARNING

Warns about hazards that may cause death, serious personal injury, or major property damage if ignored.

CAUTION

Warns about hazards that may or can cause minor personal injury or property damage if ignored.

NOTE

Indicates special instructions not related to hazards.

Carefully read and follow all safety instructions in this manual and on equipment. Keep safety labels in good condition; replace if missing or damaged.

When installing and using this electrical equipment, basic safety precautions should always be followed, include the following:

DANGER

FAILURE TO FOLLOW ALL INSTRUCTIONS AND WARNINGS CAN RESULT IN SERIOUS BODILY INJURY OR DEATH. **THIS PUMP SHOULD BE INSTALLED AND SERVICED ONLY BY A QUALIFIED POOL SERVICE PROFESSIONAL. INSTALLERS, POOL OPERATORS AND OWNERS MUST READ THESE WARNINGS AND ALL INSTRUCTIONS IN THE OWNER'S MANUAL BEFORE USING THIS PUMP. THESE WARNINGS AND THE OWNER'S MANUAL MUST BE LEFT WITH THE POOL OWNER.**

WARNING

Do not permit children to use this product.

WARNING

RISK OF ELECTRICAL SHOCK (For all permanently installed units intended for use on 15 or 20 ampere, 125 through 240 volt, single phase branch circuits). Connect only to a branch circuit protected by a ground-fault circuit-interrupter (GFCI). Contact a qualified electrician if you cannot verify that the circuit is protected by a GFCI. This unit must be connected only to a supply circuit that is protected by a ground-fault circuit-interrupter (GFCI). Such a GFCI should be provided by the installer and should be tested on a routine basis. To test the GFCI, push the test button. The GFCI should interrupt power. Push the reset button. Power should be restored. If the GFCI fails to operate in this manner, the GFCI is defective. If the GFCI interrupts power to the pump without the test button being pushed, a ground current is flowing, indicating the possibility of an electric shock. Do not use this pump. Disconnect the pump and have the problem corrected by a qualified service representative before using.

CAUTION

This pump is for use with permanent swimming pools and may also be used with hot tubs and spas if so marked. Do not use with storable pools. A permanently-installed pool is constructed in or on the ground or in a building such that it cannot be readily disassembled for storage. A storable pool is constructed so that it is capable of being readily disassembled for storage and reassembled to its original integrity.

General Warnings

- Never open the inside of the drive motor enclosure. There is a capacitor bank that holds a 230 VAC charge even when there is no power to the unit.
- The pump is not submersible.
- The pump is capable of high flow rates; use caution when installing and programming to limit pumps performance potential with old or questionable equipment.
- Code requirements for electrical connection differ from country to country, state to state, as well as local municipalities. Install equipment in accordance with the National Electrical Code and all applicable local codes and ordinances.
- Before servicing the pump; switch OFF power to the pump by disconnecting the main circuit to the pump.
- This appliance is not intended for use by persons (including children) of reduced physical, sensory or mental capabilities, or lack of experience and knowledge, unless they have been given supervision or instruction concerning the use of the appliance by a person responsible for their safety.

DANGER

SUCTION ENTRAPMENT HAZARD: STAY OFF THE MAIN DRAIN AND AWAY FROM ALL SUCTION OUTLETS! THIS PUMP IS NOT EQUIPPED WITH SAFETY VACUUM RELEASE SYSTEM (SVRS) PROTECTION AND DOES NOT PROTECT AGAINST BODY OR LIMB ENTRAPMENTS, DISEMBOWELMENTS (WHEN A PERSON SITS ON A BROKEN OR UNCOVERED POOL DRAIN) OR HAIR ENTANGLEMENTS.



THIS PUMP PRODUCES HIGH LEVELS OF SUCTION AND CREATES A STRONG VACUUM AT THE MAIN DRAIN AT THE BOTTOM OF THE BODY OF WATER. THIS SUCTION IS SO STRONG THAT IT CAN TRAP ADULTS OR CHILDREN UNDER WATER IF THEY COME IN CLOSE PROXIMITY TO A DRAIN OR A LOOSE OR BROKEN DRAIN COVER OR GRATE.

THE USE OF UNAPPROVED COVERS OR ALLOWING USE OF THE POOL OR SPA WHEN COVERS ARE MISSING, CRACKED OR BROKEN CAN RESULT IN BODY OR LIMB ENTRAPMENT, HAIR ENTANGLEMENT, BODY ENTRAPMENT, EVisCERATION AND/OR DEATH.

The suction at a drain or outlet can cause:

Limb Entrapment: When a limb is sucked or inserted into an opening resulting in a mechanical bind or swelling. This hazard is present when a drain cover is missing, broken, loose, cracked or not properly secured.

Hair Entanglement: When the hair tangles or knots in the drain cover, trapping the swimmer underwater. This hazard is present when the flow rating of the cover is too small for the pump or pumps.

Body Entrapment: When a portion of the body is held against the drain cover trapping the swimmer underwater. This hazard is present when the drain cover is missing, broken or the cover flow rating is not high enough for the pump or pumps.

EVisCeration/Disembowelment: When a person sits on an open pool (particularly a child wading pool) or spa outlet and suction is applied directly to the intestines, causing severe intestinal damage. This hazard is present when the drain cover is missing, loose, cracked, or not properly secured.

Mechanical Entrapment: When jewelry, swimsuit, hair decorations, finger, toe or knuckle is caught in an opening of an outlet or drain cover. This hazard is present when the drain cover is missing, broken, loose, cracked, or not properly secured.

NOTE: ALL SUCTION PLUMBING MUST BE INSTALLED IN ACCORDANCE WITH THE LATEST NATIONAL AND LOCAL CODES, STANDARDS AND GUIDELINES.

IMPORTANT PUMP WARNING AND SAFETY INSTRUCTIONS

⚠ WARNING TO MINIMIZE THE RISK OF INJURY DUE TO SUCTION ENTRAPMENT HAZARD:

- A properly installed and secured ANSI/ASME A112.19.8 approved anti-entrapment suction cover must be used for each drain.
- Each suction cover must be installed at least three (3') feet apart, as measured from the nearest point to nearest point.
- Regularly inspect all covers for cracks, damage and advanced weathering.
- If a cover becomes loose, cracked, damaged, broken or is missing, replace with an appropriate certified cover.
- Replace drain covers as necessary. Drain covers deteriorate over time due to exposure to sunlight and weather.
- Avoid getting hair, limbs or body in close proximity to any suction cover, pool drain or outlet.
- Disable suction outlets or reconfigure into return inlets.

⚠ WARNING The pump can produce high levels of suction within the suction side of the plumbing system. These high levels of suction can pose a risk if a person comes within the close proximity of the suction openings. A person can be seriously injured by this high level of vacuum or may become trapped and drown. It is absolutely critical that the suction plumbing be installed in accordance with the latest national and local codes for swimming pools.

⚠ WARNING A clearly labeled emergency shut-off switch for the pump must be in an easily accessible, obvious place. Make sure users know where it is and how to use it in case of emergency.

The Virginia Graeme Baker (VGB) Pool and Spa Safety Act creates new requirements for owners and operators of commercial swimming pools and spas.

Commercial pools or spas constructed on or after December 19, 2008, shall utilize:

(A) A multiple main drain system without isolation capability with suction outlet covers that meet ASME/ANSI A112.19.8a Suction Fittings for Use in Swimming Pools, Wading Pools, Spas, and Hot Tubs and either:

- (i) A safety vacuum release system (SVRS) meeting ASME/ANSI A112.19.17 Manufactured Safety Vacuum Release systems (SVRS) for Residential and Commercial Swimming Pool, Spa, Hot Tub, and Wading Pool Suction Systems and/or ASTM F2387 Standard Specification for Manufactured Safety Vacuum Release Systems (SVRS) for Swimming pools, Spas and Hot Tubs or
- (ii) A properly designed and tested suction-limiting vent system or
- (iii) An automatic pump shut-off system.

Commercial pools and spas constructed prior to December 19, 2008, with a single submerged suction outlet shall use a suction outlet cover that meets ASME/ANSI A112.19.8a and either:

- (A) A SVRS meeting ASME/ANSI A112.19.17 and/or ASTM F2387, or
- (B) A properly designed and tested suction-limiting vent system, or
- (C) An automatic pump shut-off system, or
- (D) Disabled submerged outlets, or
- (E) Suction outlets shall be reconfigured into return inlets.

⚠ CAUTION For Installation of Electrical Controls at Equipment Pad (ON/OFF Switches, Timers and Automation Load Center)



Install all electrical controls at equipment pad, such as on/off switches, timers, and control systems, etc. to allow the operation (startup, shut-down, or servicing) of any pump or filter so the user does not place any portion of his/her body over or near the pump strainer lid, filter lid or valve closures. This installation should allow the user enough space to stand clear of the filter and pump during system start-up, shut down or servicing of the system filter.

⚠ DANGER HAZARDOUS PRESSURE: STAND CLEAR OF PUMP AND FILTER DURING START UP.



Circulation systems operate under high pressure. When any part of the circulating system (i.e. locking ring, pump, filter, valves, etc.) is serviced, air can enter the system and become pressurized. Pressurized air can cause the pump housing cover, filter lid, and valves to violently separate which can result in severe personal injury or death. Filter tank lid and strainer cover must be properly secured to prevent violent separation. Stand clear of all circulation system equipment when turning on or starting up pump. Before servicing equipment, make note of the filter pressure. Be sure that all controls are set to ensure the system cannot inadvertently start during service. Turn off all power to the pump. **IMPORTANT: Place filter manual air relief valve in the open position and wait for all pressure in the system to be relieved.**

Before starting the system, fully open the manual air relief valve and place all system valves in the "open" position to allow water to flow freely from the tank and back to the tank. Stand clear of all equipment and start the pump.

IMPORTANT: Do not close filter manual air relief valve until all pressure has been discharged from the valve and a steady stream of water appears. Observe filter pressure gauge and be sure it is not higher than the pre-service condition.

General Installation Information

- All work must be performed by a qualified service professional, and must conform to all national, state, and local codes.
- Install to provide drainage of compartment for electrical components.
- These instructions contain information for a variety of pump models and therefore some instructions may not apply to a specific model. All models are intended for use in swimming pool applications. The pump will function correctly only if it is properly sized to the specific application and properly installed.

⚠ WARNING Pumps improperly sized or installed or used in applications other than for which the pump was intended can result in severe personal injury or death. These risks may include but not be limited to electric shock, fire, flooding, suction entrapment or severe injury or property damage caused by a structural failure of the pump or other system component.

Pumps and replacement motors that are single speed and one (1) Total HP or greater cannot be sold, offered for sale, or installed in a residential pool for filtration use in California, Title 20 CCR sections 1601-1609.

CUSTOMER SERVICE / TECHNICAL SUPPORT

If you have questions about ordering Pentair replacement parts, and pool products, please contact:

Customer Service and Technical Support, USA

(8 A.M. to 5 P.M. — Eastern/Pacific Times)

Phone: (800) 831-7133

Fax: (800) 284-4151

Web site

Visit www.pentair.com to find more information about Pentair products.

Sanford, North Carolina (8 A.M. to 5 P.M. ET)

Phone: (919) 566-8000

Fax: (919) 566-8920

Moorpark, California (8 A.M. to 5 P.M. PT)

Phone: (805) 553-5000 (Ext. 5591)

Fax: (805) 553-5515

TABLE OF CONTENTS

Important Pump Warning and Safety Instructions	i	Parts List	2
Motor Removal	1	Motor and Impeller Table	2
Motor Installation	1	Pump Curves	3
Pump Exploded View	2		

Motor Removal

⚠ WARNING



RISK OF ELECTRICAL SHOCK OR ELECTROCUTION.

This pool pump must be installed by a licensed or certified electrician or a qualified pool installer in accordance with the National Electrical Code (“NEC”) and/or all applicable local codes and ordinances. Improper installation will create an electrical hazard which could result in death or serious injury to pool users, installers, or others due to electrical shock, and may cause damage to property. Always disconnect power to the pool pump at the circuit breaker before servicing the pump. Failure to do so could result in death or serious injury to serviceman, pool users or others due to electric shock.

⚠ WARNING

DO NOT open the strainer pot if pump fails to prime or if pump has been operating without water in the strainer pot. Pumps operated in these circumstances may experience a build up of vapor pressure and may contain scalding hot water. Opening the strainer pot may cause serious personal injury. In order to avoid personal injury make sure the strainer pot temperature has cooled to room temperature. Carefully remove the drain plug on the strainer pot and allow the pressure to equalize before removing the locking ring.

⚠ CAUTION

DO NOT OPERATE THIS UNIT DRY. Operating this unit dry will damage the shaft seal which will cause the pump will leak.

⚠ CAUTION

Motor must be wired as indicated on motor diagram (see box cover and motor nameplate). Refer to “Motor Rotation Check” for correct pump rotation. Incorrect rotation can damage the pump.

Three Phase Motors are NOT thermally protected. Three Phase Motors MUST be installed in conjunction with a Magnetic Started equipped with Thermal Overload Protection.

1. Support motor on both sides. Remove four hex head cap screws (22) that hold motor to volute (7).
2. Carefully and slowly pull motor (23) until seal flange (17) and impeller (15) are completely out of the volute (7). Avoid resting entire unit on seal flange and impeller.
3. Remove Allen head cap screw (12) and washer (13) from center of impeller (15). Pull impeller from shaft. Do not lose square key (21).
4. Remove seal spring member (16) from shaft. Avoid cutting rubber parts or scratching carbon face.
5. Remove two hex head cap screws (19) from seal flange (17). Hold seal flange so that it does not drop on motor shaft while removing screws. Remove seal flange.
6. Remove ceramic seal face member (16) from center of seal flange (17) and o-ring (18) from groove. Check for nicks and cuts. Replace as necessary.
7. Finally, remove water slinger (20) if replacing with new one or servicing motor.

Motor Installation

1. Slip water flange (20) on motor shaft past shoulder.
2. Press ceramic seal face member (16) into center cavity of seal flange (17) with the smooth ceramic facing out. Clean and grease O-ring (18) and place in seal flange groove.

Note: Make sure that the ceramic face is free from oil or grease.

3. Install seal flange on motor register and secure in place with two cap screws (19).
4. Press seal spring member (16) on motor shaft with carbon face towards ceramic seal member. Avoid cutting rubber parts on shaft.
5. Line up keyways and push impeller (15) on motor shaft up to shoulder. Insert square key (21) in place.
6. Secure impeller with washer (13) and impeller lock screw (12).
7. Position and carefully install assembled motor to the volute (7) and secure motor using cap screws (22).
8. Remove motor shaft and cap.

9. Momentarily start and stop motor. While impeller is still turning, check the end shaft rotation. Rotation must be in the direction indicated by the arrow on the outside of the volute (7).

10. Fill Strainer pot with water, install basket and secure cover. Pump is now ready for operation. Press in motor shaft end cap.

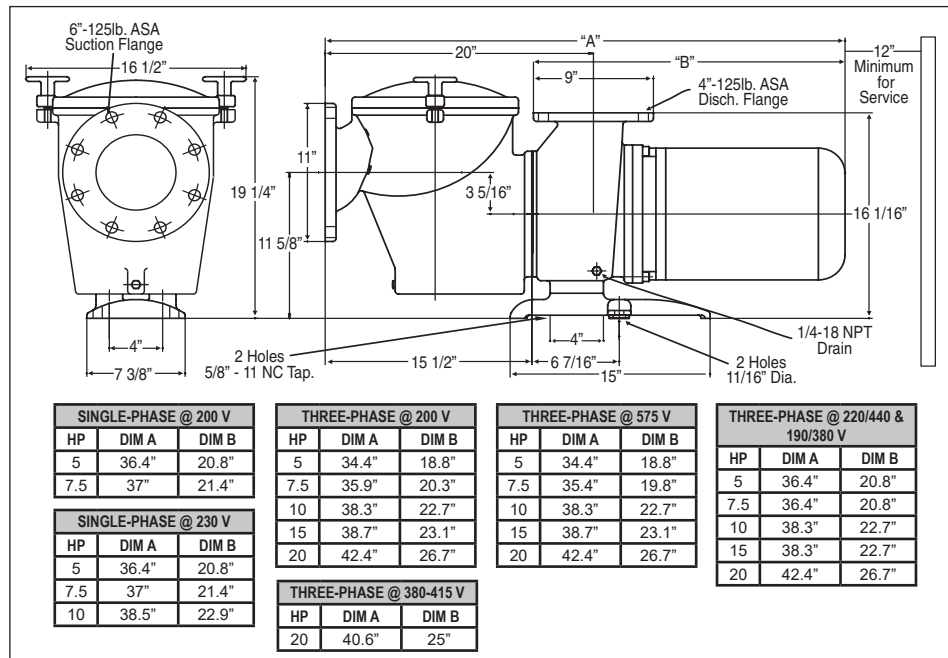

Pump Exploded View

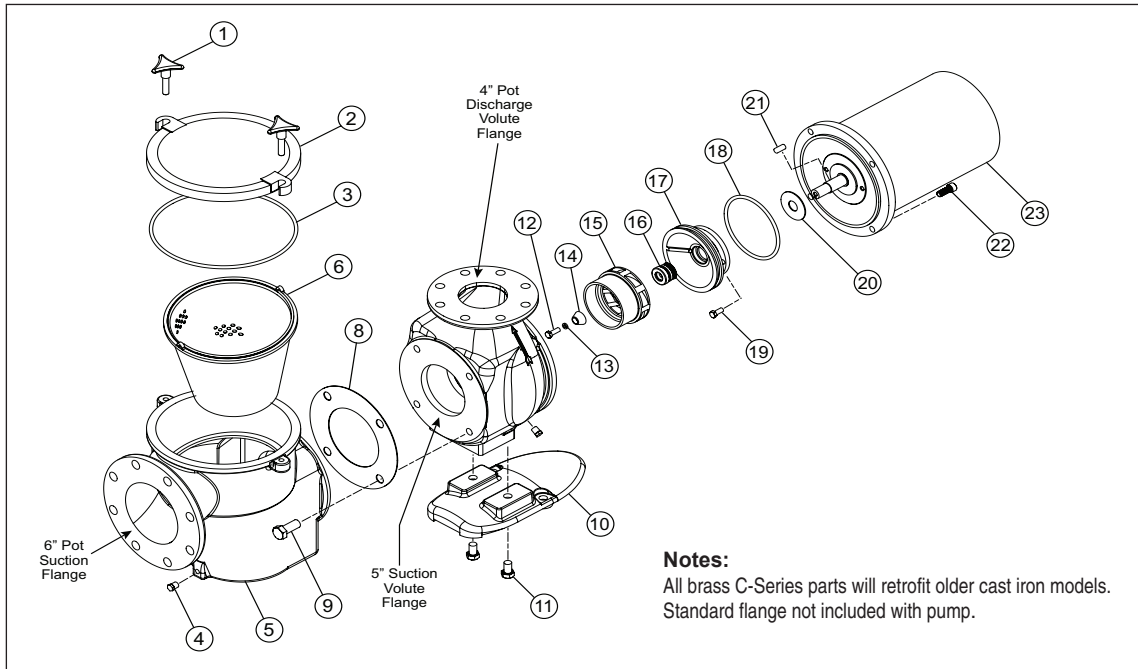

Parts List

Item	Part No.	Description
1	075280	Hand nut assembly (Qty 2)
2	075275	Cover
3	071433	Cover O-ring
4	071551	Plug Pipe, 1/4 in. (Qty 2)
5	075271Z	Strainer Pot
6	072795	Strainer Basket
7	075273Z	Volute
8	070943	Gasket Flange
9	071683	Screw 3/4 in. - 10 x 1-3/4 in., hex-head (Qty 4)
10	075287	Foot
11	071688	Screw 5/8 in. - 11 x 1 in., hex-head (Qty 2)
12	071037	Impeller Lock Screw
13	071048	Impeller Screw Washer

Item	Part No.	Description
14	075713	Impeller Washer Gasket
15	See Impeller Table Below	Impeller
16	071725	Seal
17	070906	Flange
18	071423	Flange O-ring
19	070429	Screw 3/8 in. - 16 x 3/4 in., hex-head (Qty 2)
20	072185	Water Slinger
21	071046	Impeller Key
22	071687	Screw 1/2 in. - 13 x 1-1/4 in., hex-head (Qty 4)
	357268	Screw 1/2 in. - 13 x 1-1/4 in., socket-head (Qty 4)
23	See Motor Table Below	Motor

Motor and Impeller Table

Pump Model	Motor P/Ns						Impeller P/Ns
	1PH, 230V, 60Hz	1PH, 200V, 60Hz	3PH, 200V, 60Hz	3PH 208-220/440V, 60Hz & 190/380V, 50Hz	3PH, 575V, 60Hz	3PH, 380-415V, 50Hz	
CH/CHK-50	071366	357205	357206	071364	357237	-	073828
CH/CHK-75	357204	357207	357208	071365	357247	-	073829
CH/CHK-100	357249	--	357209	071363	357238	-	073830
CH/CHK 150	--	--	357210	071361	357245	-	073831
CH/CHK-200	--	--	357211	071362	357246	072744	073832
CM/CMK-50	071366	357205	357206	071364	357237	-	070228
CM/CMK-75	357204	357207	357208	071365	357247	-	070227
CM/CMK-100	357249	--	357209	071363	357238	-	070226
CM/CMK-150	--	--	357210	071361	357245	-	070225

*Motors do not feature integral thermal protection

Pump Curves

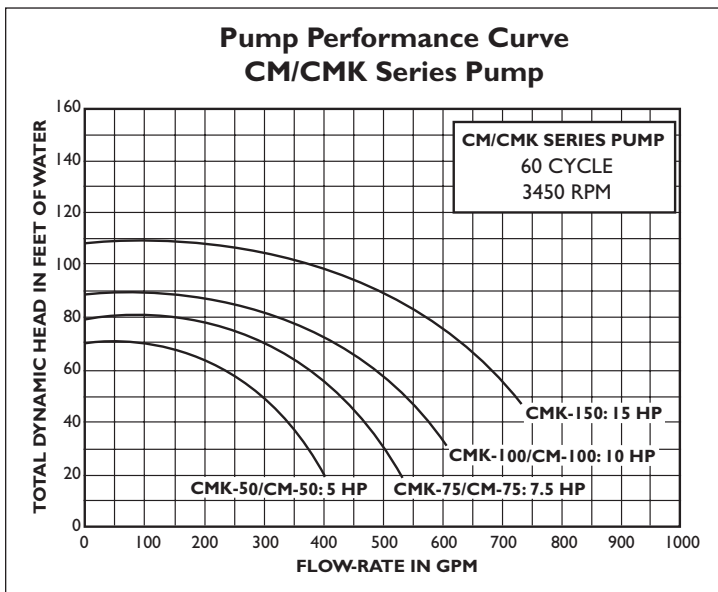
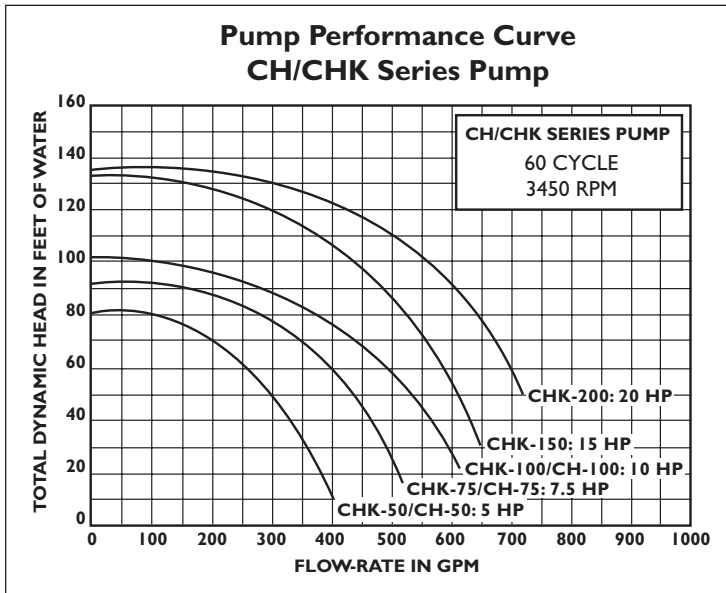

The following items are for Saudi Arabian export compliance only:

3 Phase, 60Hz, 380-400V Pumps IEC 602335-1 and 602335-2-41
 Maximum Water Temperature = 40°C Non-Submersible Pump IP Rating: IP24
 Wiring used for connection to pump must have a minimum wiring insulation rating of 90°C.

Motor HP	Maximum Total Head
5	25.00m
7.5	28.35m
10	31.10m
15	40.85m
20	42.07m



1620 HAWKINS AVE., SANFORD, NC 27330 • (919) 566-8000
10951 WEST LOS ANGELES AVE., MOORPARK, CA 93021 • (805) 553-5000

All indicated Pentair trademarks and logos are property of Pentair. Third party registered and unregistered trademarks and logos are the property of their respective owners.

© 2022 Pentair. All rights reserved. WWW.PENTAIR.COM



P/N 075277 REV. G 7/6/22