

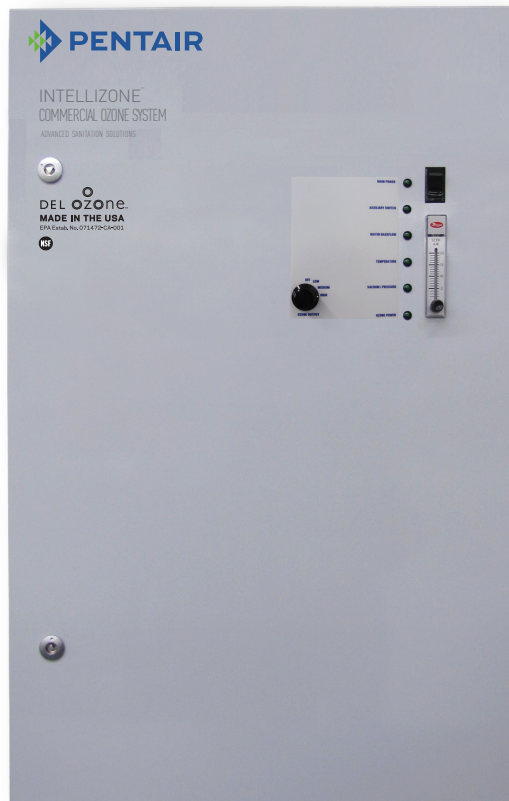

INTELLIZONE™ COMMERCIAL OZONE GENERATOR

Models CD-15G, CD-25G - All Models



INSTALLATION AND USER'S GUIDE

IMPORTANT SAFETY INSTRUCTIONS
READ AND FOLLOW ALL INSTRUCTIONS
SAVE THESE INSTRUCTIONS

TABLE OF CONTENTS

SECTION 1 General Information

Description	1
Specifications	1

SECTION 2 Installation

Location	1
Mounting	1
Electrical	2
Plumbing	2

SECTION 3 Operation

Initial System Start-Up	3
Normal Operation	3
System Shut-Down	3

SECTION 4 Maintenance & Service

System Electro-Mechanical Overview	3
PM Schedule	7
Troubleshooting	7
Contact Information	7

SECTION 5 Replacement Parts & Order Info

Ordering Information	7
----------------------------	---

Warranty	8
----------------	---

Appendix

Appendix A (Troubleshooting Guide)	8
Warranty	12
Appendix B (Safety)	13



IMPORTANT SAFETY INSTRUCTIONS

READ AND FOLLOW ALL INSTRUCTIONS.

- Read this manual completely before attempting installation.
- Risk of Electric Shock. Install the ozone unit and any metallic plumbing associated with the unit at least 5 ft from the inside wall of tub or pool.
- Risk of Electric Shock. Connect this ozone generator in accordance with the installation instructions. Do not install within an enclosure that would restrict ventilation.
- (Applicable to cord/plug connected units only) Risk of electric shock. Connect only to a properly grounded, grounding type receptacle.
- Do not bury cord.
- Warning – To reduce the risk of electric shock, replace damaged cord immediately.
- Follow all applicable electrical codes.
- Electric shock hazard. Be sure to turn power OFF at power source before any service work is performed. Failure to do so could result in serious injury or death.
- Warning – Short term inhalation of high concentrations of ozone and long term inhalation of low concentrations of ozone can cause serious harmful physiological effects. DO NOT inhale ozone gas produced by this device.
- For your safety, do not store or use gasoline, chemicals or other flammable liquids or vapors near this or any other appliance.
-  A spontaneous and violent ignition may occur if oil, grease or greasy substances come in contact with oxygen under pressure. These substances must be kept away from oxygen regulators, cylinder valves tubing and connections, and all other oxygen equipment.

SAVE THESE INSTRUCTIONS!

SECTION 1 General Information

Description

The IntelliZone™ Commercial Ozone Generator (Models CD-15G and CD-25G (521659, 521660, 521761 and 521762) described in this manual is designed to provide the benefits of ozonated water in an environmentally safe and effective manner. The high quality, specially engineered components ensure efficient ozone output and reliable performance.

This ozone generator is safe and harmless to your equipment if installed properly.

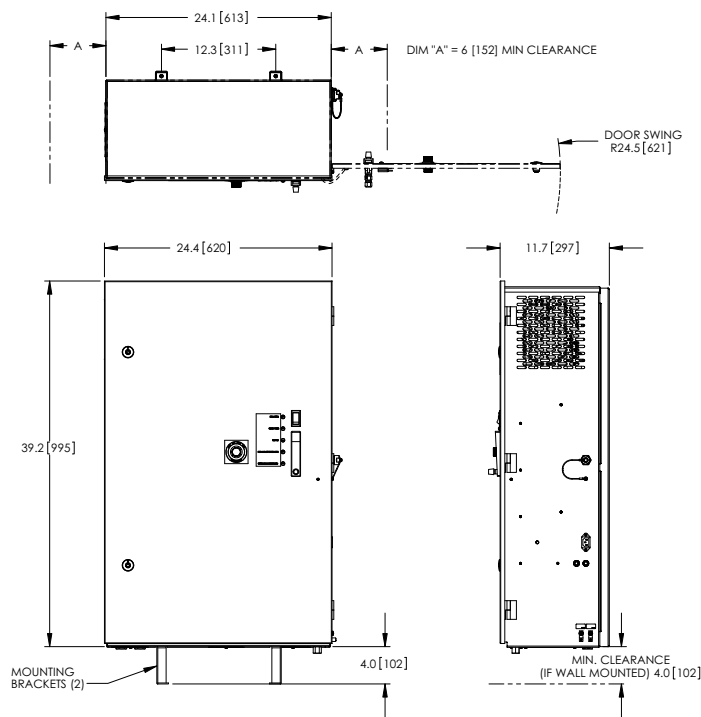

Figure 1

Specifications

For detailed specifications refer to the ozone generator specification label located on the inside of the door on the unit.

Location Requirements*:

Mounting: Floor or wall mount in a clean, protected area using supplied brackets.

Ventilation: Room should provide 6 air changes per hour

Ambient Temp.: 40–100°F (5–38°C)

* Protection from weather elements must be provided for outdoor installations. Operating outside of the recommended temp. ranges may result in damage not covered under the manufacturer's warranty.

SECTION 2 Installation

Location

The ozone generator is designed for either floor or wall mounting in a clean, protected area, either indoors or outdoors. Locate generator out of reach of sprinklers or drainage spouts. Allow sufficient access for maintenance and all tubing and electrical wires. The generator must not be placed in locations where ambient ozone levels exceed 0.01 PPM.

Mounting

NOTE: Do not remove compressor packing material until unit has been mounted.

Wall Mount Option

1. Attach two mounting brackets to wall using anchors appropriate for mounting surface. **See Figure 2.**
2. Using 1/4"-20 bolts (with washers as shown) secure generator to mounts.

Floor Mount Option

1. Use the four 1/4"-20 bolts with washers to secure feet to bottom of cabinet.
2. Stand upright and securely fasten to concrete slab using appropriate anchors and bolts.

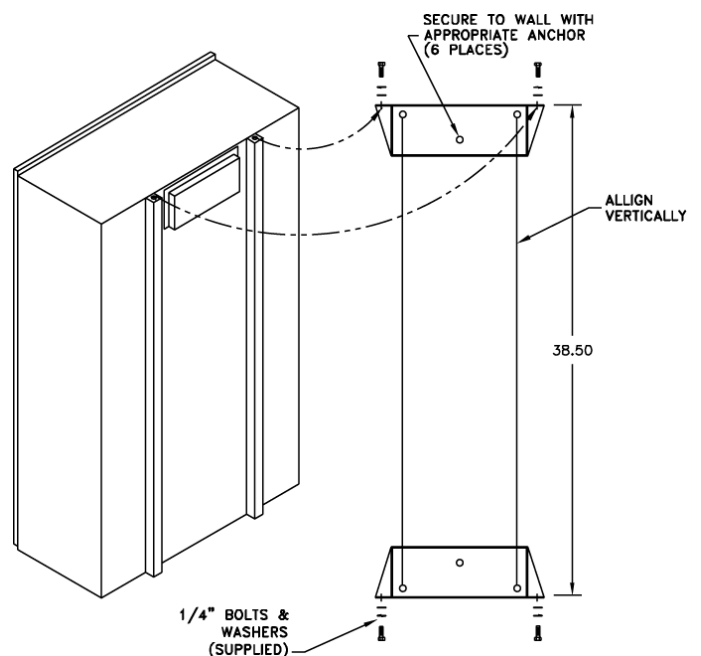

Figure 2: Wall Mount

Electrical

Refer to the units specification label and local electrical codes for information on proper electrical connection.

120V Models

Main power circuit: Unit is supplied with a standard power cord. Plug cord into standard 120V grounded, grounding type receptacle only.

230V Models

Main power circuit: 230V models are supplied with an IEC 6032 C-14 Type power receptacle. A power cord, having at least a 10AMP rating, with a IEC 60320 C-13 Type plug and a country specific plug is required to power generator.

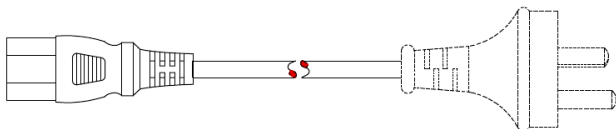

Figure 3: Country Specific Plug
(Australia shown for reference only)

Plumbing

Ozone gas is introduced to the circulation line using a venturi in-line injector. Suction developed by the venturi injector allows the generator to operate safely under vacuum. See installation manual for Model 521683 or 521684 for proper venturi installation.

Ozone Gas Line

1. Connect ozone tubing to generator outlet fitting. (3/8" stainless steel compression fitting.)
2. Connect opposite end of ozone tubing to injector suction port. (Suction port fitting: 3/8" stainless steel compression fitting.) **See Figure 4.**

NOTE: The ozone gas supply line must be made of PTFE or stainless steel and have a back flow prevention device (such as a check valve) installed between the ozone generator cabinet and the point of injection to prevent water from backing up into the generator system. An ozone supply check valve is included with the Model 521683 or 521684 system.

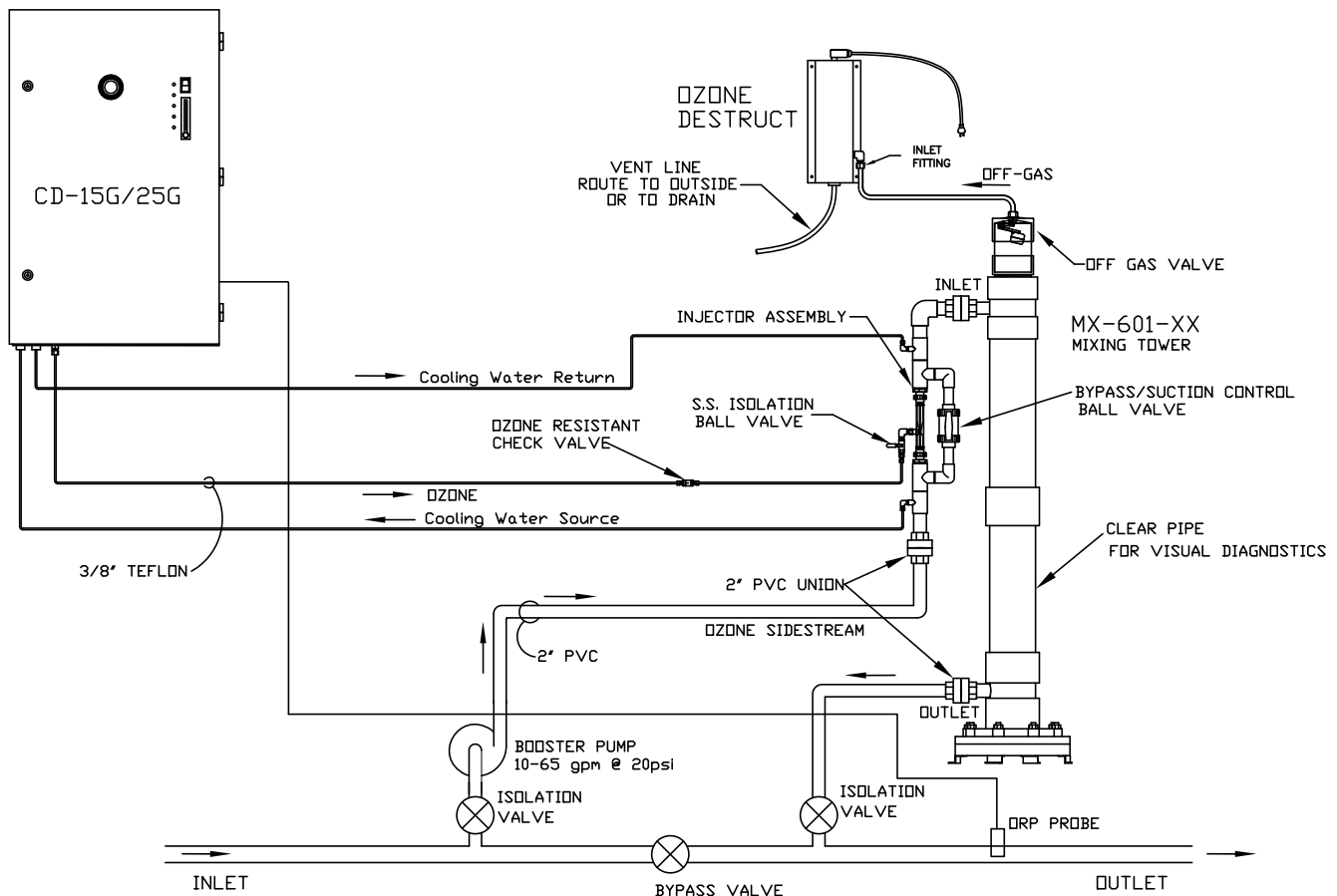

Figure 4: Plumbing Schematic - Example of Swimming Pool Application

Cooling Water

Cooling Water Flow: .1 Gpm (.4 Lpm)
 Colling water Pressure: 15–40 psi (103–275 kPa)
 Cooling Water Temp.: 5–90°F (10–32°C)

1/4" FPT connections are supplied on the generator. **See Figure 4, 5a, 6a.** Be sure that the tubing is appropriately matched with the marked inlet and outlet ports. Carefully match and connect to water plumbing as shown in Figure 4. Alternate method using connections at injector may be used.

1. The system will not start-up if the door is not secured. A door interlock switch is incorporated into the system enclosure.
2. If the optional ORP/DO3 controller is installed the system will not produce ozone if the measured level is already above the setpoint of the controller.
3. The system will not produce ozone if there is not enough vacuum being generated by water flow through injector. The red "Vacuum" light will go out when proper vacuum is attained.

If you experience complications, see APPENDIX A, TROUBLESHOOTING GUIDE or call **800.831.7133** for assistance.

SECTION 3 Operation**Initial System Start-Up**

Upon completing all of the generator system connections, you are ready to begin start-up procedures.

1. Check electrical fittings.
2. Check for proper voltage.
3. Turn on circulation pump.
4. Check for leaks.
5. With the ozone isolation valve closed, adjust the injector bypass valve and/or filtration sidestream valve to flow water through the injector.
6. Check cooling water.
7. Open the ozone isolation valve.
8. Turn main power switch to "ON" position.
9. Adjust injector by-pass to attain required vacuum. (Red "Vacuum" light will go out.) Gas flow (as indicated by the flow meter on the door of the unit) should correspond with the rating listed for the specific model on the specification label.

Normal Operation

With the power switch on, the system's compressors and cooling fans will start-up, the oxygen concentrator will begin operating, and the output solenoid valve will open. With the injector adjusted to attain the correct gas flow, the ozone generator should be producing ozone and injecting it into the process line.

Both (2) green indicator lights should be lit. If an optional ORP Controller is installed, it should be displaying a reading from the sensor probe and will automatically cycle the generator on and off as needed to maintain water quality. Residual ORP levels will vary per application.

However, the system will not start under any of the following conditions:

System Shut-Down

The ozone generator is a specialized water cooled device that must be properly protected during shut-down/storage periods. The following sequence of steps must be used for servicing or for storage.

1. Toggle the main system power switch to the "OFF" position to shut-down generator.
2. Close the ozone isolation valve to prevent water back flow.
3. After the generator has been shut-down, the process water circulation pump may be turned off.
4. If the system is going to be shut-down and stored during freezing weather, it is very important that the cooling water be drained to protect it from rupture or damage.

NOTE: Process water flow must not be shut-down when the ozone generator is operating. Doing so may cause water to backflow into the system and damage the generator cells.

SECTION 4 Maintenance & Service System Electro-Mechanical Overview

Refer to Figure 5a and 6a for component locations.

Indicator Lights

1. **Main Power:** Green light indicates that power is being supplied to the ozone generator.
2. **Ozone Power:** Green light indicates that power is being supplied to the high voltage Corona Discharge circuits and that ozone is being produced.
3. **Vacuum:** Red light indicates a low vacuum fault condition. (Refer to APPENDIX A TROUBLESHOOTING).
4. **High Coolant Temperature:** Red light indicates

cell temperature is over 110F - resulting from loss of cooling water flow. (Refer to APPENDIX "B", TROUBLESHOOTING GUIDE.)

5. **Water Backflow Detected:** Red light indicates water backflow from injector into generator. (Refer to APPENDIX "B", TROUBLESHOOTING GUIDE.)

External Components

1. **Main Power Switch:** Power switch is used for system start-up and shut-down. Switch activates the control system allowing the generator to start up.
2. **Flowmeter:** Flowmeter controls and indicates the oxygen flow through the system.
3. **Circuit Breaker:** Circuit breaker protects the generator from over current conditions. Push the breaker button to reset.

Internal Components

1. **Variable Output Switch (optional):** Adjusts high voltage power supplied to the ozone generator module controlling ozone output concentration. Located on the outside of the enclosure door.

External Devices that Control Ozone Production

The devices turn ozone production on or off based on programmed level set points. Refer to Figure 5b and 6b for connection details.

1. **ORP Controller (optional):** The ORP controller receives a millivolt (mV) signal from the ORP sensor mounted in the process water line. ORP (Oxidation-Reduction Potential) is a measure of the relative oxidation strength of the water. As ozone is added to the water system the ORP level will rise. As ozone is used up in the water system the ORP level will drop. The ORP controller continuously analyzes the sensor signal, compares it to the setpoint that has been programmed, indicates the ORP level on the digital display, and relays the signal to the ozone generator.
2. **Dissolved Ozone Monitor (optional):** Monitoring system designed for the continuous measurement of ozone gas in solution. The operating range of the system may be selected by the user from 0-2.00 PPM or from 0-20.00 PPM. The basic sensing element used is polarographic membraned sensor which measures ozone directly.

External Devices that Control System

Power

The devices turn power to the ozone generator on or off. Examples of such devices would be an ambient ozone monitor or flow switch. Refer to Figure 5b and 6b for connection details.

Internal Components

1. **Ozone Cell Assembly:** Cells are made of two aluminum halves. Enclosed in the aluminum halves are a ceramic tube, coil type high voltage electrode and a PTFE rod.
2. **High Voltage Supply(s):** Power supplies raise incoming line voltage and frequency to deliver it to the cells. Each power supply is rated at 100W.
3. **Air Compressors:** Compressors produce and supply compressed air to oxygen concentrator.
4. **Oxygen Concentrator:** Supplies concentrated, dry, oxygen feed gas to the ozone generator.
5. **Low Limit Vacuum Switch:** If the vacuum in the ozone output supply line falls below 1.5 in. Hg the switch will open causing the system to shut down.
6. **Vacuum Regulator:** Regulates the oxygen flow into the generator cell based on a vacuum setpoint (factory set to 3-5 in. Hg). When the sufficient suction is being developed by the injectors downstream the regulator will allow full flow to pass. As suction is reduced, flow is restricted proportionally to maintain the vacuum set point. If suction is lost completely, flow is cut off.
7. **Water Backflow:** The backflow detector senses water present in ozone tubing in generator. If water is detected, system will close solenoid valve to prevent additional water backflow from occurring. Water in the generator will cause severe damage to the high voltage electrodes.
8. **Ventilation Fan:** Cooling fan operates when main power switch is "ON".
9. **Air Filter:** Filter cleans ventilation air entering the enclosure.
10. **Door Interlock Switch:** Interlock switch will shut down entire system if door is opened. Securing the door will bring the system back into operation.
11. **Relay Panel:** Contains control relays for system interlocks, indicator lights and main power control.
12. **Hour Meter:** Indicates total system operating time in hours.

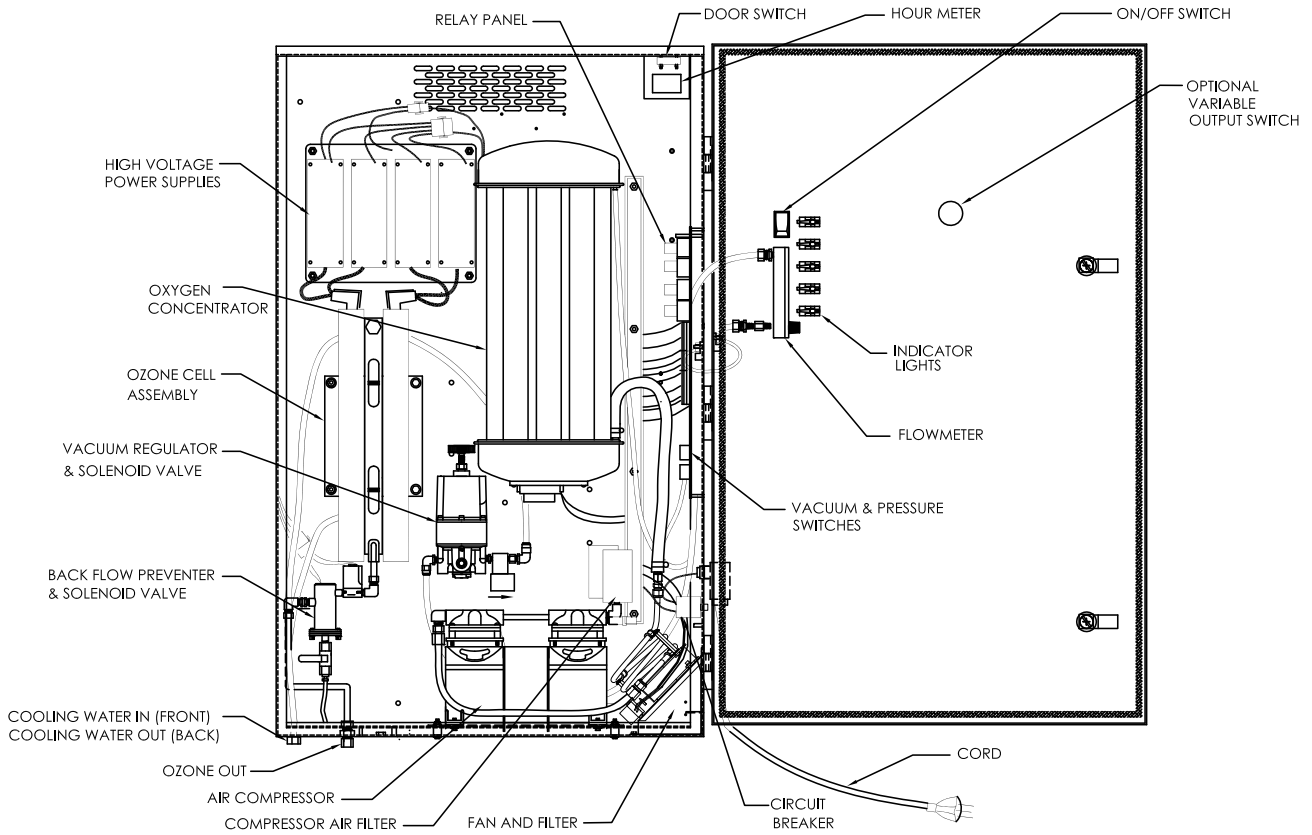

Figure 5a: Component Locations (ALL MODELS EXCEPT 521761 and 521762)

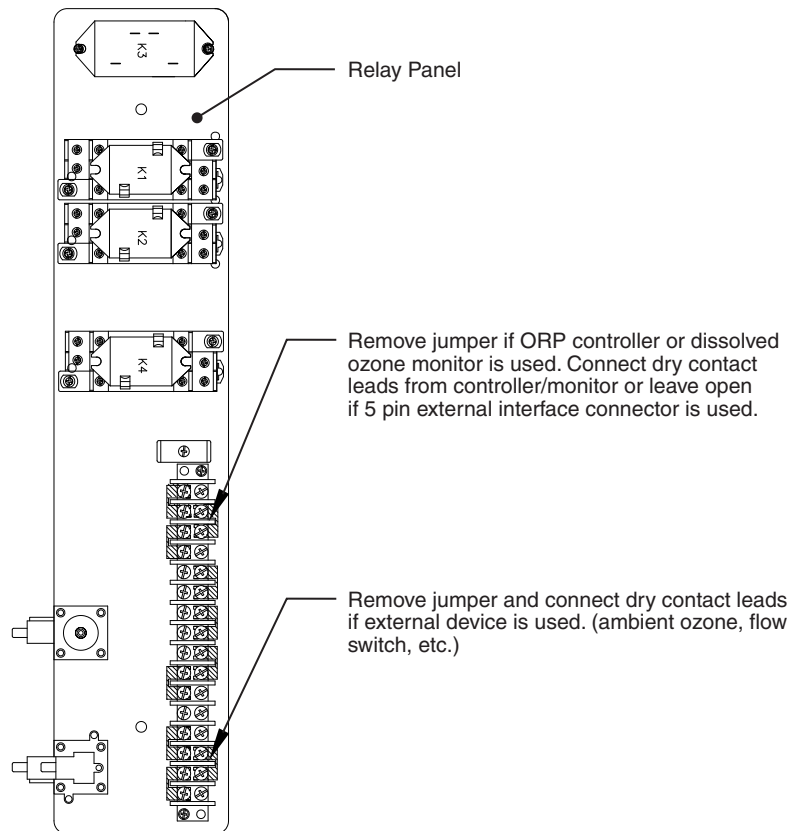

Figure 5b: Connection Details for External Control Devices (ALL MODELS EXCEPT 521761 and 521762)

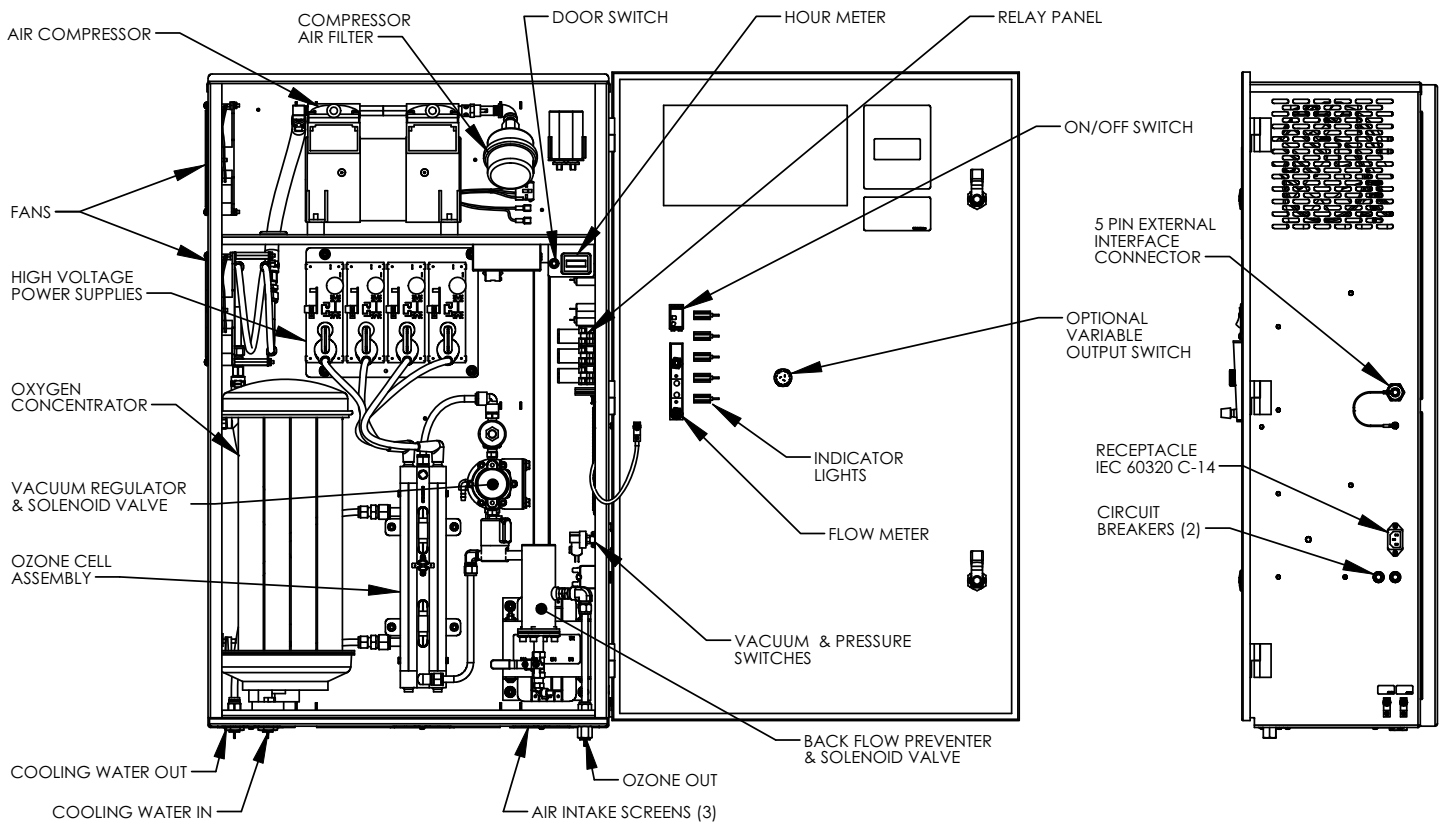

Figure 6a: Component Locations

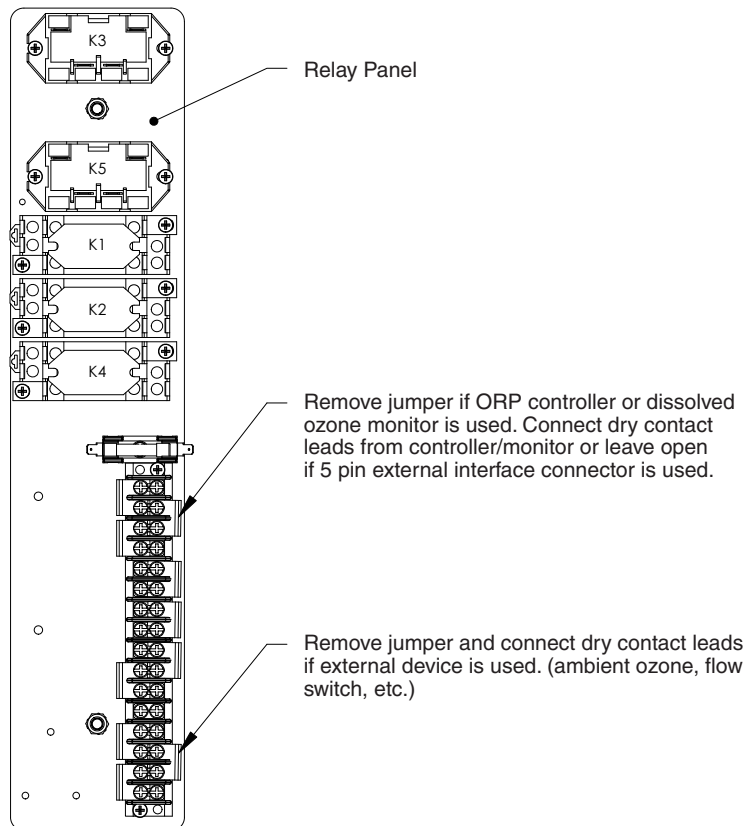

Figure 6b: Connection Details for External Control Devices

Preventative Maintenance Schedule

Regular maintenance should be performed to avoid damage to the system, more costly repairs and to keep the warranty active. For instance, the compressor should be rebuilt every 8,750 hours to prevent the reduction in air-pressure and flow. If the compressor is not rebuilt, oxygen concentrator sieve beds will become plugged and unusable, creating more costly problems. If the generator cells are not cleaned or replaced annually, a lower ozone output will result.

DAILY:

- Check ozone generator for proper operation.
- Make sure no red indicator lights are lit.
 - Make sure flow meter is indicating proper air flow.

MONTHLY:

1. Inspect compressor air filter.
 - Replace quarterly
2. Remove and clean air filter or intake screens

See Figure 7.

 - Remove filter cover plate to access filter.
 - Rinse filter in warm, soapy water and blow dry.
 - Replace filter.
 - For models 521761 and 521762, remove and clean intake screens.
3. Perform general cleaning of cabinet interior.

EVERY 8,750 HOURS:

1. Rebuild compressor. Kit Available. See Section 5 for ordering information.
2. Replace/Service Check Valve(s) and Solenoid Valves.
3. Replace ozone cell O-rings and inspect ozone cells.

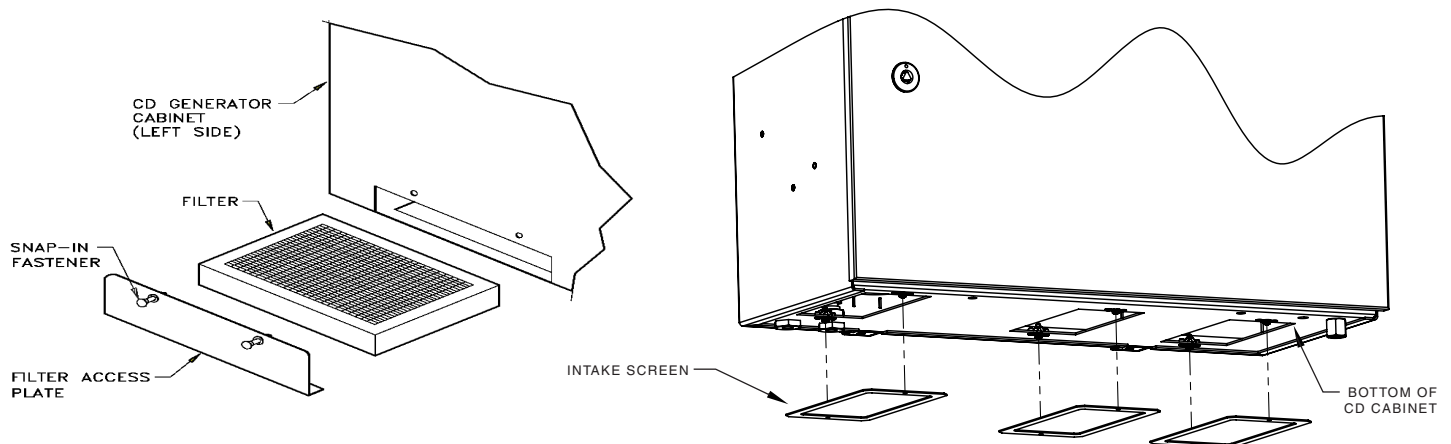

Figure 7: Filter or Intake Screen Removal for Cleaning

Troubleshooting

See APPENDIX A TROUBLESHOOTING.

NOTE: Knowledge of electrical applications is required for trouble shooting. Contact a certified electrician if you are unsure of your ability to service the equipment. If any condition persists, call 800.831.7133 for technical assistance.

Contact Information

For Technical assistance:

Call: 800.831.7133

Visit: www.pentaircommercial.com

www.pentairpool.com

SECTION 5 Replacement Parts & Order Information

Ordering information

For replacement parts call 800.831.7133

Be prepared with the following information:

- Customer Name
- Customer Address
- Model Number
- Serial Number

APPENDIX A TROUBLESHOOTING

TROUBLESHOOTING FOR CD-15G & 25G SERIES OZONE GENERATORS

The following information can help resolve problems that might arise in operation of the CD-15G & 25G Series ozone generators. It contains three main sections that when used together provide a basic overview of the ozone generator layout, troubleshooting table for common problems, and electrical, pneumatic, and hydraulic order diagrams. If you still need help, call **800.831.7133**.

Note: Always disconnect the ozone generator from the power source before attempting service or repair.

Image 1: Ozone Generator Component Locations (CD-25GV model shown)

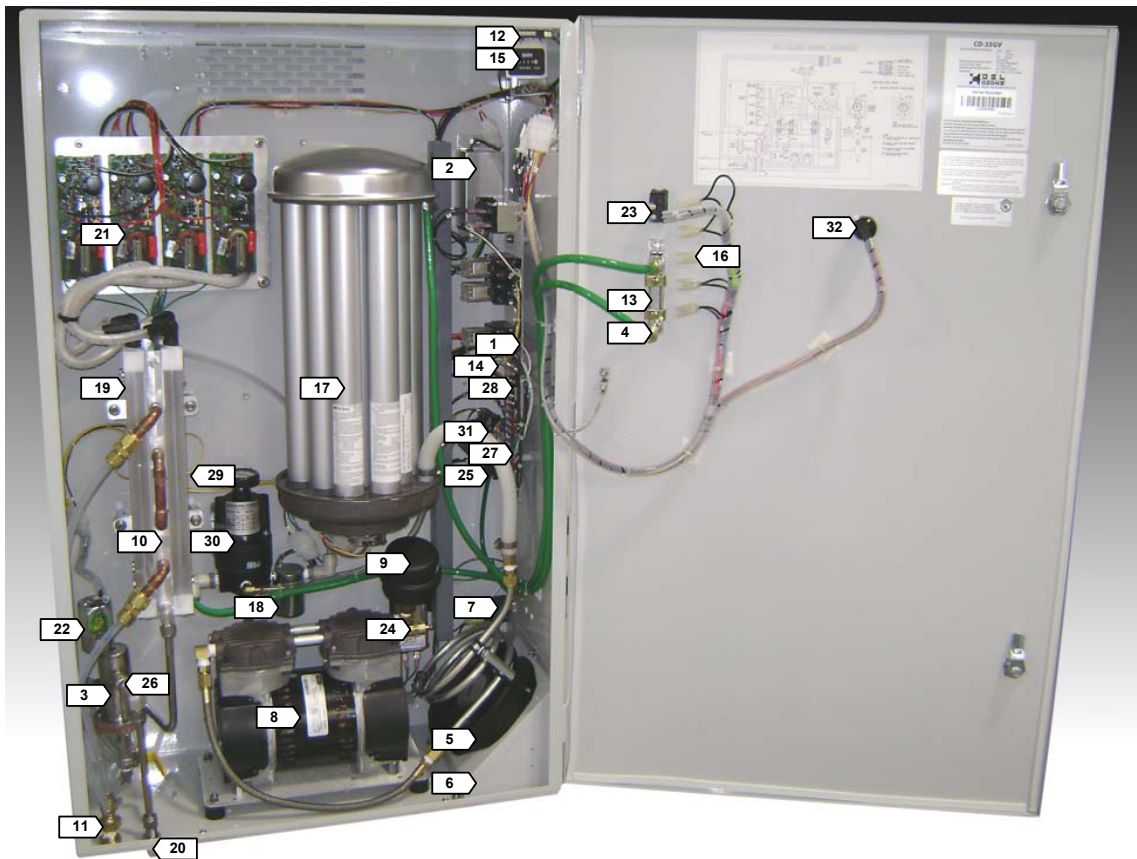

1. 5-Pin connector (not shown)	12. Door switch	23. Power switch
2. 12VDC power supply (optional)	13. Flowmeter	24. Pressure relief valve
3. Backflow prevention device (BFPD)	14. Fuse	25. Pressure switch
4. Brass orifice	15. Hourmeter	26. S.S. check valve
5. Cabinet fan	16. Indicator lights	27. Terminal block 1 (TB1)
6. Cabinet filter (not shown)	17. Oxygen concentrator	28. Terminal block 4 (TB4)
7. Circuit breaker	18. Oxygen solenoid valve	29. Thermal switch (not shown)
8. Compressor	19. Ozone cells	30. Vacuum regulator
9. Compressor air filter	20. Ozone output fitting	31. Vacuum switch
10. Cooling block assembly	21. Ozone power supplies	32. Variable ozone output control (optional)
11. Cooling water in & out fittings	22. Ozone solenoid valve	

Table 1: Troubleshooting (for best results follow the table order)

Problem (Indication)	Possible Cause	Corrective Action
1. Unit does not start (main power light is off and no sound is coming from the unit)	a. Unit is not supplied power	Connect unit to power source Turn power source breaker on Reset power source G.F.C.I. Verify power source voltage is within unit specification
	b. Unit door switch is open	Close unit door
	c. Unit power switch is in off position	Turn power switch on
	d. Unit circuit breaker is tripped	Reset circuit breaker
2. Unit is in vacuum fault (vacuum light is on)	a. Inadequate vacuum is supplied to unit	Connect unit to vacuum source (injector) Adjust injector to provide more vacuum Fix leak or obstruction in plumbing between injector and unit
	b. Unit S.S. check valve has failed	Clean or replace S.S. check valve
	c. Unit vacuum switch has failed	Replace vacuum switch
	d. Unit vacuum regulator requires adjustment or has failed	Call service department for assistance
3. Unit is in high temperature fault (high coolant temperature light is on)	a. Unit thermal switch has tripped	Reduce supplied cooling water temperature and/or increase flow rate Obstruction or scaling in cooling block assembly (clean or replace)
	b. Unit thermal switch has failed	Replace thermal switch
4. Unit is in backflow fault (water backflow detected light is on)	a. Water has returned from injection point and triggered unit back flow float switch	Disconnect ozone line between injector and unit at ozone output fitting, drain BFPD vessel, and replace SS check valve
5. Unit does not flow gas (flowmeter at bottom of scale)	a. Unit flowmeter valve is closed	Adjust flowmeter valve open
	b. Unit jumper(s) at TB1 are removed (optional system control hookup, e.g. flow switch and/or ambient O3)	Re-install jumper(s) and/or verify system control(s) are operational
	c. Unit fuse is blown	Replace fuse
	d. Unit pressure switch is not active	Verify unit plumbing between oxygen concentrator and pressure switch is securely connected Replace compressor air filter Rebuild compressor Replace oxygen concentrator
	e. Unit orifice is plugged	Clean or replace orifice
	f. Unit solenoid valve(s) has failed	Clean or replace solenoid valve(s)
	g. Unit flowmeter ball is stuck on bottom of sight tube	Repair or replace flowmeter
	h. Unit vacuum regulator requires adjustment or has failed	Call service department for assistance
6. Unit ozone production does not start (both ozone power and vacuum lights are off)	a. Unit jumper at TB4 is removed (optional external ozone control hookup, e.g. ORP or dissolved O3, directly wired or through 5-Pin)	Re-install jumper and/or verify external ozone control is operational
7. Unit does not provide effective sanitation (both main power and ozone power lights are on)	a. Unit variable ozone output control setting is too low (optional feature)	If so equipped, increase ozone output setting
	b. Leak in plumbing that dilutes applied ozone dose	Fix leak in plumbing (inside unit and/or between unit and injector)
	c. Low gas flow and/or low oxygen concentration	Replace unit compressor air filter
		Clean or replace unit orifice
		Clean or replace unit check valve
d. Unit ozone cell has reached service life or failed	Rebuild unit compressor Replace unit oxygen concentrator Replace ozone cell	
e. Unit ozone power supply has failed	Replace power supply	

Electrical Component Order Diagram

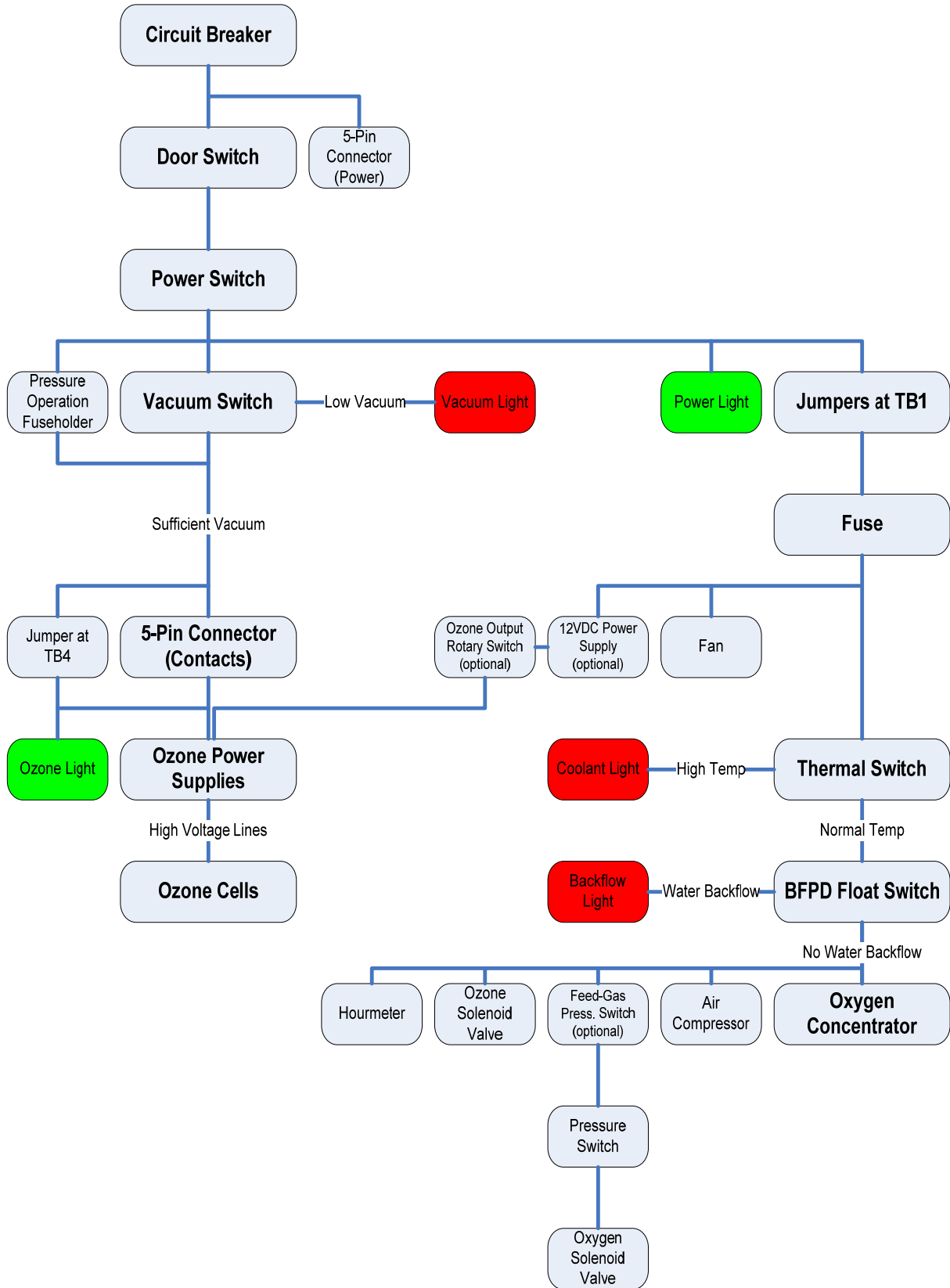

Pneumatic Component Order Diagram

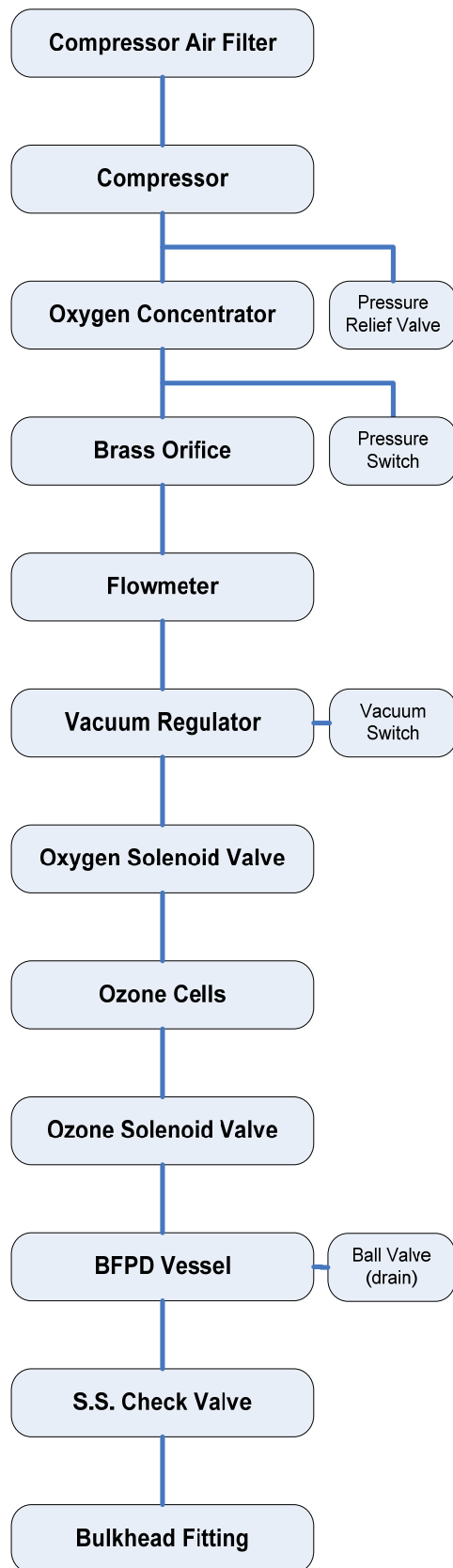

Hydraulic Component Order Diagram

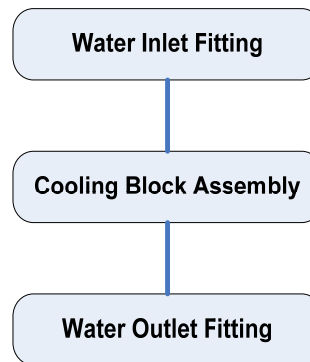

LIMITED WARRANTY

Pentair Aquatic Systems warrants the IntelliZone™ Commercial Ozone Generator (Models CD-15G and CD-25G (521659, 521660, 521761 and 521762) as follows:

Limited Warranty: Pentair warrants the (Models CD-15G and CD-25G (521659, 521660, 521761 and 521762) to be free from defects in material and/or workmanship for a period of two (2) years from the original date of installation.

Exceptions that shall result in Pentair's denial of a warranty claim:

1. Damage caused by careless handling, improper repackaging, or shipping.
 2. Damage due to misapplication, misuse, abuse or failure to operate equipment as specified in the (Models CD-15G and CD-25G (521659, 521660, 521761 and 521762) Installation and User's Guide.
 3. Damage caused by failure to install products as specified in the (Models CD-15G and CD-25G (521659, 521660, 521761 and 521762) Installation and User's Guide.
 4. Damage due to unauthorized product modifications or alterations, or failure to use Pentair original replacement parts.
 5. Damage caused by negligence, or failure to properly maintain products as specified in the (Models CD-15G and CD-25G (521659, 521660, 521761 and 521762) Installation and User's Guide.
 6. Damage caused by failure to maintain water chemistry in conformity with the standards set forth in the (Models CD-15G and CD-25G (521659, 521660, 521761 and 521762) Installation and User's Guide.
 7. Damage caused by water scaling, freezing or any conditions causing inadequate water circulation.
 8. Accidental damage, fire, acts of God, or other circumstances outside the control of Pentair.
- This warranty extends to the original retail owner (Customer) only, beginning on the date of installation and is not enforceable by any other party. Proof of purchase and/or date of installation will be required for all warranty claims. Customer agrees to pay all shipping charges to Pentair.
 - Warranties by others: Some products incorporate components manufactured by other manufacturers. Some of these provide warranties in addition to the warranty provided herein. In all such cases a copy of that warranty will be provided with the product. To the extent protection provided under any such third party warranty exceeds the Limited Warranty provided herein, the Customer must look only to that other manufacturer for the additional warranty protection.
- Warranty Obligations of Pentair: Should a defect in workmanship and/or material in any item covered by this warranty become evident during the term of the warranty, then upon the Customer following the procedures set forth below, Pentair will, at its option, repair or replace such item or part at its own cost and expense. Pentair's maximum obligation under this warranty is limited to the repair and replacement of the (Models CD-15G and CD-25G (521659, 521660, 521761 and 521762). Pentair disclaims all other expressed or implied warranty obligations.

Pentair is not, however, responsible under this warranty for any cost of shipping or transportation of the equipment or parts thereof to or from Pentair's Technical Service Department. Also, Pentair is not liable for any loss of time, inconvenience, incidental expenses such as telephone calls, labor or material charges incurred in connection with the removal or replacement of the equipment, or any other incidental or consequential damages, including but not limited to damage to pool equipment or any surface in or around the pool in which the (Models CD-15G and CD-25G (521659, 521660, 521761 and 521762) is installed.

PLEASE NOTE: Some states do not allow the exclusion or limitation of incidental, or consequential damages, so the above limitation or exclusion may not apply to you.

No Other Warranties: TO THE MAXIMUM EXTENT PERMITTED BY APPLICABLE LAW, PENTAIR DISCLAIMS ALL OTHER WARRANTIES, WHETHER EXPRESS OR IMPLIED, INCLUDING, BUT NOT LIMITED TO THE IMPLIED WARRANTIES OF MERCHANTABILITY AND FITNESS FOR A PARTICULAR PURPOSE.

Procedure for Obtaining Performance: In order to obtain the benefits of this warranty, the Customer who made the original retail purchase must contact the Pentair Technical Service Department upon discovery of the defect, but in no event later than the expiration date of the warranty period provided in this warranty. Upon receipt of this communication, Pentair will promptly notify the Customer of the address to which the defective item may be shipped. The Customer shall then ship the item, freight prepaid, to the address indicated, together with a "RETURN GOODS AUTHORIZATION" form obtained from Pentair Technical Service and a brief description of the problems encountered. Unauthorized returns will not be accepted. Freight must be prepaid by customer.

Warranties or Representations by Others: No dealer or other third party entity has any authority to make any warranties or representations concerning Pentair or its products. Accordingly, Pentair is not responsible for any such warranties or representations.

Other Rights: This warranty gives you specific legal rights and you may also have other rights, which vary from state to state. This warranty supersedes all previous publications.

Pentair Aquatic Systems.

1620 Hawkins Ave. Sanford, NC 27330 - 10951 W. Los Angeles Ave. Moorpark, CA 93021 - Phone 800-831-7133 - Fax 800-284-4151

APPENDIX - SAFETY

OZONE

Material Safety Data Sheet

SECTION I: MATERIAL IDENTIFICATION	
IDENTITY: OZONE (Gaseous)	ISSUED: February, 1992
FORMULA: O ₃	REVISED: April 3, 2012
<p>Description (origin/uses): Occurs in atmosphere from UV light action on oxygen at high altitude. Commercially obtained by passing air between electrodes carrying a high voltage alternating current. Also found as a by-product in welding areas, high voltage equipment, or UV radiation.</p> <p>Ozone is used as an oxidizing agent in air and water disinfection: for bleaching textiles, oils, and waxes; organic synthesis as in processing certain perfumes, vanillin, camphor; for mold and bacteria control in cold storage.</p>	
<p>Cautions: A powerful oxidizing agent, ozone generally exists as a gas and is highly chemically reactive. Inhalation produces various degrees of respiratory effects from irritation to pulmonary edema (fluid in lungs) as well as affecting the eyes, blood, and central nervous system.</p>	
<p>Manufacturer/Supplier: On-site generation, equipment available from various suppliers, including:</p> <p>DEL Ozone Phone: (805) 541-1601 3580 Sueldo Street FAX: (805) 541-8459 San Luis Obispo, CA 93401</p>	
SECTION II: INGREDIENTS AND HAZARDS	
Ozone, CAS No. 10028-15-6; NIOSH RTECS No. RS8225000	
1991 OSHA PELs 8-hr TWA: 0.1 ppm vol. (0.2 mg/m ³) 15-min STEL: 0.3 ppm vol (0.6 mg/m ³)	1991-1992 ACGIH TLV Ceiling: 0.1 ppm (0.2 mg/m ³)
1990 IDLH 10 ppm	1990 DFG (Germany) MAK TWA: 0.1 ppm (0.2 mg/m ³) Category 1: Local Irritant
1990 NIOSH REL Ceiling: 0.1 ppm vol. (0.2 mg/m ³)	Peak Exposure Limit: 0.2 ppm 5 min momentary value, 8 per shift
<p>Other Designations: Triatomic oxygen: CAS No. 10028-15-6, NIOSH RTECS No. RS8225000</p>	
SECTION III: PHYSICAL DATA	
Boiling Point: -169° F	Melting Point: -315.4° F (-193° C)
Vapor Pressure: >1 ATM	% Volatile by Volume: 100%
Vapor Density (AIR = 1): 1.6	Molecular Weight: 48 Grams/Mole
Solubility in Water: 0.49 ml @ 32° F (0° C), 3 ppm @ 20° C	pH: Not Listed
	Critical Temperature: 10.22° F (-12.1° C)
<p>Appearance and Odor: Colorless to blue gas (greater than -169° F); characteristic odor often associated with electrical sparks or lightning in concentrations of less than 2 ppm and becomes disagreeable above 1-2 ppm. CAUTION: Olfactory fatigue develops rapidly, so do not use odor as a preventative warning device.</p>	
SECTION IV: FIRE AND EXPLOSION HAZARD DATA	
Flash Point: Nonflammable	
Extinguishing Media: Use large amounts of water spray or fog to put out fires involving ozone. Use appropriate fire-fighting techniques to deal with surrounding material.	
<p>Special Fire Fighting Procedures: Wear a self contained breathing apparatus with full face pieces operated in a pressure-demand or other positive-pressure mode.</p>	
<p>Unusual Fire/Explosion Hazards: Decomposition of ozone into oxygen gas, (O₂), can increase strength of fire.</p>	
SECTION V: REACTIVITY DATA	
<p>Stability: Ozone is not stable. Hazardous polymerization cannot occur.</p>	
<p>Chemical Incompatibilities: Ozone is chemically incompatible with all oxidizable materials, both organic and inorganic.</p>	
<p>Conditions to Avoid: Ozone is unstable at room temperatures and spontaneously decomposes to oxygen gas. Avoid ignition sources such as heat, sparks, and open flame. Keep away from strong reducing agents and combustible materials such as grease, oils, and fats.</p>	
<p>Products of Hazardous Decomposition: Ozone spontaneously decomposes to oxygen gas, even at room temperatures.</p>	

4-0697_Rev.C

SECTION VI: HEALTH HAZARD DATA

Carcinogenicity: Ozone is not listed as a carcinogen by the NTP, IARC, or OSHA.

Primary Entry: Inhalation

Target Organs: Respiratory system, eyes, blood.

Summary of Risks: There is no true threshold limit and so no exposure (regardless of how small) is theoretically without effect from ozone's strong oxidative ability. Ozone passes straight to the smallest bronchioles and alveoli and is not absorbed by mucous membranes along the way. Initial small exposure may reduce cell sensitivity and/or increase mucous thickness producing a resistance to low ozone levels. Short exposure to 1-2 ppm concentrations causes headache as well as irritation to the respiratory tract, but symptoms subside when exposure ends. High concentrations of ozone produce severe irritation of the eyes and respiratory tract. Exposure above the ACGIH/OSHA limits produce nausea, chest pain, coughing, fatigue, reduced visual acuity, and pulmonary edema. Symptoms of edema from excessive exposure can be delayed one or more hours. Inhalation of >20 ppm for an hour or more (>50 ppm for 1/2 hour) can be fatal.

Acute Effects: Acute damage from ozone appears to be mainly from its oxidizing effect on contact with tissue.

Chronic Effects: Respiratory disease. Deleterious effects on lungs and acceleration of tumors have been reported.

Medical Conditions Generally Aggravated by Long-Term Exposure: History of respiratory or heart disorders.

First Aid: Remove from ozone containing air, get prompt medical help*, administer oxygen if necessary.

Eye Contact - Gently lift eyelids and flush eyes continuously with flooding amounts of water for 15 minutes or until transported to a medical facility*.

Inhalation - Remove exposed person to fresh air, support breathing, administer humidified oxygen as needed, get medical help*.

Ingestion - Highly unlikely since ozone is a gas until -169° F,

* **GET MEDICAL ASSISTANCE = APPROPRIATE IN-PLANT, PARAMEDIC, or COMMUNITY.** Get prompt medical assistance for further treatment, observation, and support after first aid.

SECTION VII: PRECAUTIONS FOR SAFE HANDLING AND USE

Steps to be Taken in Case of Spill/Leak:

1. Discontinue production
2. Isolate and vent area
3. Immediately notify personnel
4. Deny entry
5. Follow applicable OSHA regulations

Disposal: Provide ventilation to dilute and disperse small amounts of ozone (below OSHA PELs) to outside atmosphere. Follow federal, state, and local regulations.

Handling/Storage Precautions: Ensure proper personnel training and establish emergency procedures.

SECTION VIII: CONTROL MEASURES

Respiratory Protection: High Level (>10 ppm) - Self Contained Breathing Apparatus: MISH/NIOSH approved.
Low Level (0.3 - 10 ppm) - Canister Type (carbon) respirator may be used.

Eye Protection: Wear chemical safety goggles if necessary to work in high ozone (>10 ppm).

Skin Protection: Effects of ozone on skin are minimal to non-existent.

Ventilation: Provide general and local exhaust ventilation to dilute & disperse small amounts of ozone into outside atmosphere.

SECTION IX: SPECIAL PRECAUTIONS AND COMMENTS

Storage Segregation: Prevent ozone from coming into direct physical contact with strong acids or bases or with strong oxidizing/reducing agents.

Engineering Controls: Install ventilation systems capable of maintaining ozone to concentrations below the ACGIH/OSHA exposure limits (see sect. II). Install ambient ozone monitor(s) configured to shut down ozone equipment and turn high speed ventilation on.

Material Safety Data Sheet

This MSDS complies with OSHA's Hazardous Communication Standard 29 CFR 1910.1200 and OSHA form 174.

DEL Ozone
3580 Sueldo Street
San Luis Obispo, CA 93401

Product Information 805-541-1601

NFPA 704 Designation Hazard Rating

4 = Extreme
 3 = High
 2 = Moderate
 1 = Slight
 0 = Insignificant

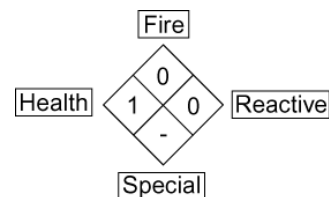

Product Name	AQUEOUS OZONE SOLUTION				
Chemical Name	DISSOLVED OZONE GAS IN WATER 0 TO 2 PPM				
Product Description	AQUEOUS SOLUTION OF OZONE DISSOLVED IN POTABLE WATER				
D.O.T. Shipping Classification	NON REGULATED				
I PHYSICAL DATA					
Boiling Point	212 F	Freezing Point	32 F		
Specific Gravity	1.0	Solubility in Water	COMPLETE		
Evaporation Rate	APPROX 1	Physical Form	LIQUID		
Appearance & Odor	COLORLESS (CLEAR) WATER WITH FRESH, ASEPTIC ODOR				
II HAZARDOUS INGREDIENTS					
MATERIAL	HAZARD	CAS #	% BY WT	ACGIH TLV	OSHA PEL
None					
III FIRE AND EXPLOSION HAZARD DATA					
Flash Point	NA	Method	NA	Auto Ign. Temp.	NA
Flammable Limits in Air	NON APPLICABLE		Lower	NA	Upper NA
Extinguishing Media	NON APPLICABLE				
Unusual Fire & Explosion Hazards	NONE				
Special Fire Fighting Procedures	NONE				

4-1444-01_Rev.C

Material Safety Data Sheet Cont.

Product Name **AQUEOUS OZONE SOLUTION**

IV HEALTH HAZARD DATA	
Threshold Limit Value	NOT DETERMINED
Route of Exposure	<input type="checkbox"/> Inhalation <input type="checkbox"/> Ingestion <input type="checkbox"/> Skin <input checked="" type="checkbox"/> Eye <input checked="" type="checkbox"/> Not Hazardous
Eye Contact Hazard	Exposure may cause mild eye irritation, but is not expected.
Ingestion Hazard	Not Hazardous
Inhalation Hazard	Inhalation is not likely to be a primary route of exposure but could become irritating if aerosols are exposed to individual for extended period of time.
Skin Contact Hazard	No skin irritation is expected from short term exposure.
Skin Absorption Hazard	No published data indicates this product is absorbed through the skin.
Effects of Acute Exposure	Mild skin or eye irritation.
Effects of Chronic Exposure	Repeated exposure of the skin to concentrated product should be avoided to prevent irritation and drying of the skin.
V EMERGENCY AND FIRST AID PROCEDURES	
Eye Contact	If exposure to water containing aqueous solution of ozone causes irritation to eyes, flush eyes with plenty of clean, ozone free, running water for at least 15 minutes, lifting the upper and lower lids occasionally. Remove contact lenses if worn. Seek medical attention if irritation persists.
Skin Contact	Not likely to become irritated unless repeatedly exposed to large volumes of material. If irritation develops, rinse affected area with ozone free potable water. If irritation continues seek medical advice.
Inhalation	Inhalation of mists could lead to irritation of lungs. If symptoms develop, move individual away from exposure and into fresh air. If symptoms persist, seek medical attention.
Ingestion	NA
VI REACTIVITY DATA	
Incompatibility (Materials to Avoid)	Natural rubber (may degrade, or "dry", rubber components over extended periods of exposure)
Conditions to Avoid	NONE KNOWN
Hazardous Decomposition	NONE
Stability	<input checked="" type="checkbox"/> STABLE <input type="checkbox"/> UNSTABLE Hazardous Polymerization <input type="checkbox"/> MAY OCCUR <input checked="" type="checkbox"/> WILL NOT OCCUR

4-1444-01_Rev.C

Material Safety Data Sheet Cont.Product Name **AQUEOUS OZONE SOLUTION**

VII SPILL OR LEAK PROCEDURES				
Steps To Be Taken If Material Is Released Or Spilled		NONE		
Waste Disposal Method		DISPOSE OF THE SAME AS POTABLE RINSE WATER		
VIII SPECIAL PROTECTIVE INFORMATION				
Respiratory Protection (Specify Type)		NOT REQUIRED FOR NORMAL USE OF THIS PRODUCT		
Ventilation	Local Exhaust	PREFERABLE	Special	NA
	Mechanical (general)	OK	Other	NA
Protective Gloves	NOT REQUIRED			
Eye Protection	NOT REQUIRED			
Other Protective Equipment	NOT REQUIRED			
IX SPECIAL PRECAUTIONS				
Precautionary Labeling	Certified testing of DEL Ozone systems by NSF (National Sanitation Foundation) has shown that under normal conditions of use, aqueous solutions containing low levels of ozone gas dissolved in potable water do not present a safety hazard when contact to the individual is incidental. When used in a room with normal ventilation, levels of ozone gas being released into the air have been shown by NSF to be well below the periodic exposure levels established by OSHA for worker safety through the use of DEL's ozone management technology.			
Precautions To Be Taken In Handling	Aqueous solutions of ozone in potable water should not be sprayed as an aerosol (i.e. >20psi) to avoid releasing higher levels of ozone gas into the work area. The decay rate of ozone gas is a function of temperature and exposure to organic material. Certified testing has shown that when ozone gas has been properly dissolved in ambient temperature (or colder (33 – 70 °F)) potable water at a level not exceeding 2 mg/l (ppm) using DEL's ozone management technology, the rate at which ozone is released from the water as ozone gas is below the PEL established for gaseous ozone.			
				Rev. Date 03/26/12
This material safety data sheet is provided as an information resource only. It should not be taken as a warranty or representation for which the preparer assumes legal responsibility. While we believe the information contained herein is accurate and compiled from sources believed to be reliable, it is the responsibility of the user to investigate and verify its validity. The buyer assumes all responsibility of using and handling the product in accordance with applicable federal, state, and local regulations.				

4-1444-01_Rev.C

Notes

Notes



© 2012 Pentair Aquatic Systems. All rights reserved.

This document is subject to change without notice.

1620 Hawkins Ave., Sanford, NC 27330 • (919) 566-8000
10951 West Los Angeles Ave., Moorpark, CA 93021 • (805) 553-5000

All Pentair trademarks and logos are owned by Pentair, Inc. Pentair Aquatic Systems™ and IntelliZone™ are trademarks and/or registered trademarks of Pentair Water Pool and Spa, Inc. and/or its affiliated companies in the United States and/ or other countries. Unless expressly noted, names and brands of third parties that may be used in this document are not used to indicate an affiliation or endorsement between the owners of these names and brands and Pentair Water Pool and Spa, Inc. Those names and brands may be the trademarks or registered trademarks of those third parties. Because we are continuously improving our products and services, Pentair reserves the right to change specifications without prior notice. Pentair is an equal opportunity employer.



P/N 521810 Rev A - 6/4/12