

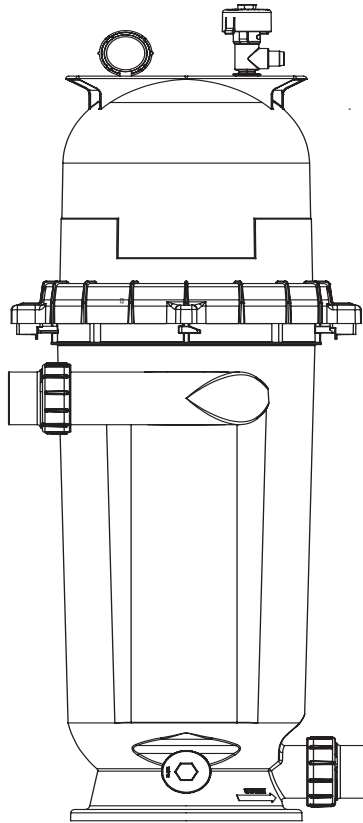

SEP 100<sup>®</sup>

D.E. SEPARATION TANK



# INSTALLATION AND USER'S GUIDE

IMPORTANT SAFETY INSTRUCTIONS  
*READ AND FOLLOW ALL INSTRUCTIONS*  
SAVE THESE INSTRUCTIONS



# IMPORTANT WARNING AND SAFETY INSTRUCTIONS



## Important Notice:

This guide provides installation and operation instructions for this product. Consult Pentair with any questions regarding this equipment.

**Attention Installer:** This guide contains important information about the installation, operation and safe use of this product. This information should be given to the owner and/or operator of this equipment after installation or left on or near the filter.

**Attention User:** This manual contains important information that will help you in operating and maintaining this filter. Please retain it for future reference.

### READ AND FOLLOW ALL INSTRUCTIONS SAVE THESE INSTRUCTIONS



This is the safety alert symbol. When you see this symbol on your system or in this manual, look for one of the following signal words and be alert to the potential for personal injury.



**DANGER** Warns about hazards that can cause death, serious personal injury, or major property damage if ignored.



**WARNING** Warns about hazards that may cause death, serious personal injury, or major property damage if ignored.



**CAUTION** Warns about hazards that may or can cause minor personal injury or property damage if ignored.

**NOTE** indicates special instructions not related to hazards. Carefully read and follow all safety instructions in this manual and on equipment. Keep safety labels in good condition; replace if missing or damaged.



Before installing this product, read and follow all warning notices and instructions which are included.

Failure to follow safety warnings and instructions can result in severe injury, death, or property damage. Call US: (877) 347-4788 - INT: (407) 886-3939 for additional free copies of these instructions.

### Consumer Information and Safety

This filter is designed and manufactured to provide many years of safe and reliable service when installed, operated and maintained according to the information in this manual and the installation codes referred to in later sections. Throughout the manual, safety warnings and cautions are identified by the “” symbol. Be sure to read and comply with all of the warnings and cautions.



Do not operate the filter until you have read and understand clearly all the operating instructions and warning messages for all equipment that is a part of the circulating system.

The following instructions are intended as a guide for initially operating the filter in a general installation, however each installation may have unique conditions where the starting procedure could be different. Failure to follow all operating instructions and warning messages can result in severe injury, death, or property damage.



Do not permit children to use or operate this filter.



### FILTER OPERATES UNDER HIGH PRESSURE.

When any part of the circulating system, (e.g., clamp, pump, filter, valve(s), etc.), is serviced, air can enter the system and become pressurized. Pressurized air can cause the lid to separate which can result in severe injury, death, or property damage.



To avoid this potential hazard, follow these instructions:

1. Before repositioning valve(s) and before beginning the assembly, disassembly, or adjustment of the clamp or any other service of the circulating system: (A) Turn the pump **OFF** and **shut OFF** any automatic controls to ensure the system is NOT inadvertently started during the servicing; (B) open the manual air relief valve; (C) stand clear of the filter; (D) wait until all pressure is relieved.
2. Whenever installing the filter clamp **FOLLOW THE FILTER CLAMP INSTALLATION INSTRUCTIONS EXACTLY.**
3. Once service on the circulating system is complete **FOLLOW SYSTEM RESTART INSTRUCTIONS EXACTLY.**
4. Maintain circulation system properly. Replace worn or damaged parts immediately, (e.g., clamp, pressure gauge, valve(s), o-rings, etc).
5. Be sure that the filter is properly mounted and positioned according to instructions provided.



Due to the potential risk that can be involved it is recommended that the pressure test be kept to the minimum time required by the local code. Do not allow people to work around the system when the circulation system is under pressure test. Post



appropriate warning signs and establish a barrier around the pressurized equipment. If the equipment is located in an equipment room, lock the door and post a warning sign.

Never attempt to adjust any closures or lids or attempt to remove or tighten bolts when the system is pressurized. These actions can result in a separation or failure of system components. This instantaneous release of energy can cause components to be accelerated to high velocities and to travel far distances. These components could cause severe personal injury or death if they were to strike a person.



Never exceed the maximum operating pressure of the system components. Exceeding these limits could result in a component failing under pressure. This instantaneous release of energy can cause the closure to separate and could cause severe personal injury or death if they were to strike a person.



### RISK OF ELECTRICAL SHOCK OR ELECTROCUTION.

This filter must be installed by a qualified service professional in accordance with the current National Electrical Code and all applicable local codes and ordinances.



Always disconnect power to the equipment at the circuit breaker before servicing any of the equipment. Ensure that the disconnected circuit is locked out or properly tagged so that it cannot be switched on while you are working on the equipment. Failure to do so could result in serious injury or death to serviceman, pool users or others due to electric shock. Position the filter and the air relief valve to safely direct water drainage and purged air or water. Water discharged from an improperly positioned filter or valve can create an electrical hazard that can cause severe personal injury as well as damage property.

# IMPORTANT WARNING AND SAFETY INSTRUCTIONS

**⚠ DANGER** SERIOUS BODILY INJURY OR DEATH CAN RESULT IF THIS FILTER IS NOT INSTALLED AND USED CORRECTLY.

**⚠ DANGER** INSTALLERS, OPERATORS AND OWNERS MUST READ THESE WARNINGS AND ALL INSTRUCTIONS BEFORE USING THIS FILTER.

**⚠ DANGER** HAZARDOUS PRESSURE: STAND CLEAR OF PUMP AND FILTER DURING START UP



Circulation systems operate under high pressure. When any part of the circulating system (i.e. locking ring, pump, filter, valves, etc.) is serviced, air can enter the system and become pressurized.

Pressurized air can cause the pump housing cover filter lid and valves to violently separate which can result in severe personal injury or death. Filter tank lid and strainer cover must be properly secured to prevent violent separation. Stand clear of all circulation system equipment when turning on or starting up pump.

Before servicing equipment, make note of the filter pressure. Be sure that all controls are set to ensure the system cannot inadvertently start during service. Turn off all power to the pump. **IMPORTANT: Place filter manual air relief valve in the open position and wait for all pressure in the system to be relieved.**

Before starting the system, fully open the manual air relief valve and place all system valves in the “open” position to allow water to flow freely from the tank and back to the tank. Stand clear of all equipment and start the pump.

**IMPORTANT: Do not close filter manual air relief valve until all pressure has been discharged from the valve and a steady stream of water appears.** Observe filter pressure gauge and be sure it is not higher than the pre-service condition.

**For Installation of Electrical Controls at Equipment Pad (ON/OFF Switches, Timers and Automation Load Center)**

**⚠ CAUTION** Install all electrical controls at equipment pad, such as on/off switches, timers, and control systems, etc. to allow the operation (startup, shut-down, or servicing) of any pump or filter so the user does not place any portion of his/her body over or near the pump strainer lid, filter lid or valve closures.



This installation should allow the user enough space to stand clear of the filter and pump during system start-up, shut down or servicing of the system filter.

**⚠ CAUTION** The following information should be read carefully since it outlines the proper manner of care and operation for your filter system. As a result of following these instructions and taking the necessary preventative care, you can expect maximum efficiency and life from your filtration system.

## General Installation Information

The following information should be read carefully since it outlines the proper manner of care and operation for your filter system.

You can expect maximum efficiency and life from your filtration system by following these instructions and taking the necessary preventative care.

- Have a trained professional perform all pressure tests.
- Do not connect the system to a high pressure or city water system.
- Trapped air in the system can create a hazardous condition. BE SURE to purge all air from the system before operating or testing equipment.
- DO NOT pressure test with compressed air!
- Piping must conform to local/state plumbing and sanitary codes.
- Support piping independently to prevent strains on filter or valve.
- Fittings restrict flow; for best efficiency, use the fewest possible fittings.
- A check valve installed ahead of the filter inlet will prevent contaminants from draining back into the system.
- A check valve installed between the filter and heater will prevent hot water from backing up into the filter and deforming the internal components.
- All wiring, grounding and bonding of associated equipment must meet current local and/or National Electrical Code standards.

*Only a qualified plumbing professional should install this filter. Refer to the “Important Warning and Safety Instructions on pages iii-iv for additional installation and safety information.*

# SAVE THESE INSTRUCTIONS

# INSTALLATION

**WARNING** Before installing this product, read and follow all warning notices and instructions which are included. Failure to follow safety warnings and instructions can result in severe injury, death, or property damage. Call US: (877) 347-4788 - INT: (407) 886-3939 for additional free copies of these instructions.

## Separation Tank Installation

1. The Sep 100® D.E. Separation Tank should be mounted on a level concrete slab. Position the tank so that the instructions, warnings and pressure gauge are visible to the operator. Also, position the separation tank so that the piping connections, control valve and drain port are convenient and accessible for servicing and winterizing.
2. Separation tanks are designed to work primarily with diatomaceous earth (D.E.) swimming pool or spa filters. Their purpose is to separate the D.E. and dirt from filter effluent during the backwash cycle. The separation process should produce water out of the separation tank suitable for return back to the pool or disposal into city storm drain systems. The separation process uses a large cloth "filter" bag to literally filter out the D.E. and its entrapped dirt particles. During backwashing of a D.E. filter, a valve is used to reverse the normal flow through the filter. The reverse flow dislodges the D.E. cake from the filter and flushes it into the top of the filter bag. The D.E. and dirt are captured in the bag and clean water passes through and exits from the tank bottom (outlet). After backwashing the filter, the separation tank needs to be opened and the bag cleaned before another backwashing cycle.
3. Install electrical controls (e.g., on/off switches, timers control systems, etc.) at least five (5) feet from the tank, with enough room to stand clear of the tank during system start up.
4. Provide sufficient clearance around the tank to permit visual verification that the clamp is properly installed, see **Figure 1**.
5. Provide sufficient space above the filter to remove the filter lid for cleaning and servicing.

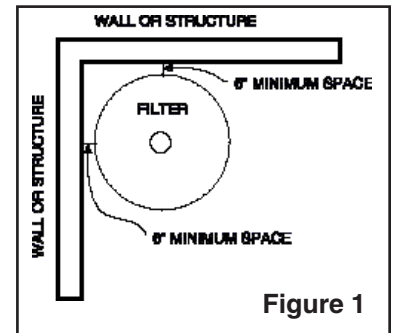

**WARNING** Risk of electrical shock or electrocution. Position the separation tank and manual air relief valve to safely direct water drainage and purged air or water. Water discharged from an improperly positioned tank or valve can create an electrical hazard that can cause severe personal injury as well as damage property.

6. When installing the High Flow™ Manual Air Relief Valve use the O-ring only; there is no need for thread sealing compounds. Position the filter to safely direct water drainage. Rotate the valve to safely direct purged air or water. Water discharged from an improperly positioned filter or valve can create an electrical hazard as well as damage property.
7. Make all plumbing connections in accordance with local plumbing and building codes. Plumbing connections are provided with an O-ring seal. Use only a silicone base lubricant on the O-rings. Do not use pipe joint compound, glue or solvent on the bulkhead connections.
8. The base of the separation tank is provided with four (4) mounting bosses for the purpose of anchoring the tank to the concrete.
9. The maximum working pressure of the separation tank is 50 psi. Never subject the separation tank to pressure in excess of this amount, even when conducting hydrostatic pressure tests. Pressures above 50 psi can cause the lid to separate from the tank, which can result in severe injury, death or property damage.

When performing hydrostatic pressure tests or when testing for external leaks of the completed filtration and plumbing system, ensure that the Maximum Pressure that the filtration system will be subjected to DOES NOT EXCEED THE MAXIMUM WORKING PRESSURE OF ANY OF THE COMPONENTS CONTAINED WITHIN THE SYSTEM. In most cases, the maximum pressure will be stated on each component of the system.

If doubt exists as to the pressure to which the system will be subjected, install an ASME approved automatic Pressure Relief or Pressure Regulator in the circulation system for the lowest working pressure of any of the components in the system.

## Bypass Valves

**WARNING** If the separation tank is plumbed to return water to waste, a positive shut off valve is NOT recommended in the line from the separation tank. If the system is operated with such a valve closed, the pressure in the entire system would go abnormally high and could present a risk of the lid and tank separation. Additionally, running the system with no flow will seriously damage the equipment through heat build-up.



If the separation tank is plumbed to return water back to the pool, a bypass valve must be used. This valve must be closed when not backwashing through the separation tank so that the separation tank is not under pressure when in the normal filter mode.

# OPERATION

## **⚠ WARNING**



### **THIS FILTER OPERATES UNDER HIGH PRESSURE**

When any part of the circulating system, (e.g., lock ring, pump, filter, valve(s), etc.), is serviced, air can enter the system and become pressurized. Pressurized air can cause the tank lid to separate which can result in severe injury, death, or property damage. To avoid this potential hazard, follow these instructions:

1. If you are not familiar with your pool filtering system and/or heater:
  - a. **Do NOT** attempt to adjust or service without consulting your dealer, or a qualified pool technician.
  - b. Read the entire Installation & User's Guide before attempting to use, service or adjust the pool filtering system or heater.
2. Before repositioning valve(s) and before beginning the assembly, disassembly, or any other service of the circulating system: (A) Turn the pump **OFF** and **shut OFF** any automatic controls to ensure the system is NOT inadvertently started during the servicing; (B) open the manual air bleeder valve; (C) wait until all pressure is relieved.
3. Whenever installing the filter lock ring, **FOLLOW THE LOCK RING INSTALLATION INSTRUCTIONS (PAGE 3) EXACTLY.**
4. Once service on the circulating system is complete, **FOLLOW INITIAL SYSTEM RESTART INSTRUCTIONS (PAGE 3) EXACTLY.**
5. Maintain circulation system properly. Replace worn or damaged parts immediately, (e.g., closure, pressure gauge, valve(s), o-rings, etc).
6. Be sure that the separation tank is properly mounted and positioned according to instructions provided.

## General Information

1. The Sep 100® D.E. Separation Tank operates under pressure. When the lock ring is installed properly and operated without air in the water system, the separation tank will operate in a safe manner.

## **⚠ WARNING**



The maximum working pressure of the separation tank is 50 psi. Never subject the tank to pressure in excess of this amount - even when conducting hydrostatic pressure tests. Pressures above 50 psi can cause lid separation, which can result in serious injury, death or property damage.

When performing hydrostatic pressure tests or when testing for external leaks of the completed filtration and plumbing system, ensure that the Maximum Pressure that the filtration system will be subjected to **DOES NOT EXCEED THE MAXIMUM WORKING PRESSURE OF ANY OF THE COMPONENTS CONTAINED WITHIN THE SYSTEM.** In most cases, the maximum pressure will be stated on each component of the system.

If doubt exists as to the pressure to which the system will be subjected, install an ASME approved automatic Pressure Relief or Pressure Regulator in the circulation system for the lowest working pressure of any of the components in the system.

2. The pressure gauge is the primary indicator of how the separation tank is operating. Maintain your pressure gauge in good working order.

## **⚠ WARNING**

Your separation tank is a piece of machinery, do not tamper with it, attempt to disassemble it or otherwise adjust it unless you fully understand it's operation. Serious injury or death can occur if the equipment is improperly handled. Consult a pool service professional for maintenance and service assistance.

3. Clean your filter when pressure reads between 8-10 psi higher than the original starting pressure. Your filter pressure reading will increase as it removes dirt from your pool. However, this buildup of pressure will vary due to different bathing loads, temperature, weather conditions, etc.
4. Change valve positions;
  - if using a multi-port valve, set to backwash position.
  - if using a two position valve, reposition the valve to backwash position.
  - if separation tank is plumbed to return water to pool, open by-pass valve.
  - open manual air bleed on top of separation tank.
5. Stand clear of filter and separation tank. Start pump, this will circulate water backwards through the filter and flush D.E. cake and contaminants into the separation tank. Close the manual air bleed on the top of the separation tank when a steady stream of water emerges.

- Continue to Next Page -



## General Information (Cont.)

6. When the backwashing action is complete, (see your filter operating instructions), stop the pump.
7. Change valve positions;
  - set filter valve to filter position.
  - close separation tank by-pass valve.
  - open manual air bleed on top of separation tank..
8. Disassemble and clean your separation tank following the instructions given herein.

## Lock Ring Installation

These instructions **MUST BE FOLLOWED EXACTLY** to prevent the lid from separating from the tank during system restart or later operation.

### **WARNING**



THE SEP 100® D.E. SEPARATION TANK OPERATES UNDER HIGH PRESSURE. WHEN ANY PART OF THE CIRCULATING SYSTEM (e.g., LOCK RING, PUMP, FILTER, VALVES, ETC.) IS SERVICED, AIR CAN ENTER THE SYSTEM AND BECOME PRESSURIZED. PRESSURIZED AIR CAN CAUSE THE LID TO SEPARATE WHICH CAN RESULT IN SEVERE INJURY, DEATH, OR PROPERTY DAMAGE. TO AVOID THIS POTENTIAL HAZARD, FOLLOW THESE INSTRUCTIONS.

1. Perform the following steps before working on any part of the circulating system (e.g., lock ring, pump, filter, valves, etc.).
  - a. Turn the pump off and shut off any automatic controls to ensure that the system is not inadvertently started during servicing.
  - b. Open the High Flow™ Manual Air Relief Valve.
  - c. Wait until all pressure is relieved. **Never attempt to assemble, disassemble or adjust the filter lock ring while there is any pressure in the tank.**
2. Be certain the O-ring is in position in the lower tank half. Place the filter lid over the lower tank half, making sure it is fully and firmly seated on the tank half, see **Figure 2**.
3. Place lock ring over the tank lid, and centering the lock ring on the threads of the tank body. Turn the lock ring clockwise until the safety latches click and the lock ring hits the stops on the body. **DO NOT ATTEMPT TO OVER-TIGHTEN THE LOCK RING AFTER LOCK RING HAS HIT THE STOPS ON THE BODY.**
4. Follow the System Restart instructions below.

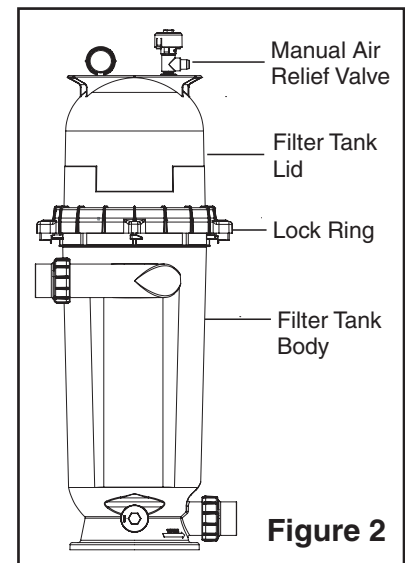

## System Restart

### **WARNING**



THE SEPARATION TANK OPERATES UNDER HIGH PRESSURE. WHEN ANY PART OF THE CIRCULATING SYSTEM (e.g., LOCK RING, PUMP, FILTER, VALVES, ETC.) IS SERVICED, AIR CAN ENTER THE SYSTEM AND BECOME PRESSURIZED. PRESSURIZED AIR CAN CAUSE THE LID TO SEPARATE WHICH CAN RESULT IN SEVERE INJURY, DEATH, OR PROPERTY DAMAGE. TO AVOID THIS POTENTIAL HAZARD, FOLLOW THESE INSTRUCTIONS.

1. **Open the manual air relief valve until it snaps into the full open position (this only requires a quarter turn counter-clockwise).** Opening this valve rapidly releases air trapped in the tank.
2. Stand clear of the tank, then start the pump.
3. Close the manual air relief valve after a steady stream of water appears.
4. The system is not working properly if either of the following conditions occur.
  - a. A solid stream of water does not appear within 30 seconds, after the pump's inlet basket fills with water.
  - b. The pressure gauge indicates pressure before water outflow appears.

If either condition exists, **shut off the pump immediately**, open valves in the water return line to relieve pressure, and clean the air relief valve according to *Cleaning the Air Relief Valve* on page 4. If the problem persists, call (800) 831-7133 for assistance.

# MAINTENANCE

## Cleaning the Separation Tank

**WARNING** The following information should be read carefully since it outlines the proper manner of care and operation for your filter system. As a result of following these instructions and taking the necessary preventative care, you can expect maximum efficiency and life from the filter system.

**CAUTION** Please heed all manufacturers' posted instructions, warnings and cautions when using polyhexamethylene biguanide sanitizers or other filter cleaning solutions.

1. Turn the pump off, shut off any automatic controls to ensure that the system is not inadvertently started during servicing.
  2. Open the High Flow™ Manual Air Relief Valve, (and the waste drain valve, or cap, if your system has one).
  3. Remove hair and lint strainer pot lid and clean basket. Replace basket and secure lid.
  4. Open the drain valve and wait for the water to drain from the Sep 100® D.E. Separation Tank before removing the bag containing D.E. and contaminants.
  5. Remove locking ring by depressing safety latches on both sides of ring and rotate counterclockwise, then remove tank lid.
  6. Remove the separation bag by pulling straight up on the bag handle loop.
  7. Dispose of waste in trash and rinse bag clean. Inspect bag for holes - replace if necessary.
  8. Clean and remove debris from inside the filter tank and from the O-ring and O-ring groove on the tank body.
  9. Install the clean bag into the tank assembly making sure it is seated onto the separation tank ring.
  10. Replace the tank lid onto the tank body making sure it is fully and firmly seated on the tank body.
  11. Place lock ring over tank lid, and centering the lock ring on the threads of the tank body, turn the lock ring clockwise until the safety latches click and the lock ring hits the stops on the body. **DO NOT ATTEMPT TO OVERTIGHTEN THE LOCK RING AFTER LOCK RING HAS HIT THE STOPS ON THE BODY.**
- Note:** Any time the separation tank is opened, and/or separation bag is removed, be sure to generously coat the O-ring with silicone lubricant before reassembling the unit. **DO NOT USE PETROLEUM BASED LUBRICANTS BECAUSE THEY HAVE A DETERIORATING EFFECT ON RUBBER.**
12. Replace drain cap and reinstall manual air relief valve drain hose if used.

## Cleaning the Air Relief Valve

1. Turn the pump off and shut off any automatic controls to ensure that the system is not inadvertently started during servicing.
2. **OPEN THE HIGH FLOW MANUAL AIR RELIEF VALVE UNTIL IT SNAPS INTO THE FULL OPEN POSITION, THEN WAIT UNTIL ALL PRESSURE IS RELIEVED.**
3. With the relief valve attached to the filter tank, pull out the locking tabs and remove the valve stem and cover assembly with a counterclockwise and lifting motion, see **Figure 3**.
4. Clean debris from the valve stem and body. Verify that the filter tank's air passage is open by inserting a 5/16 in. drill bit through the valve body. Verify that the O-ring are in good condition, properly positioned, and lubricated with a silicone base lubricant.
5. Reinstall the valve stem and cover assembly with a downward and clockwise motion until it snaps into position.

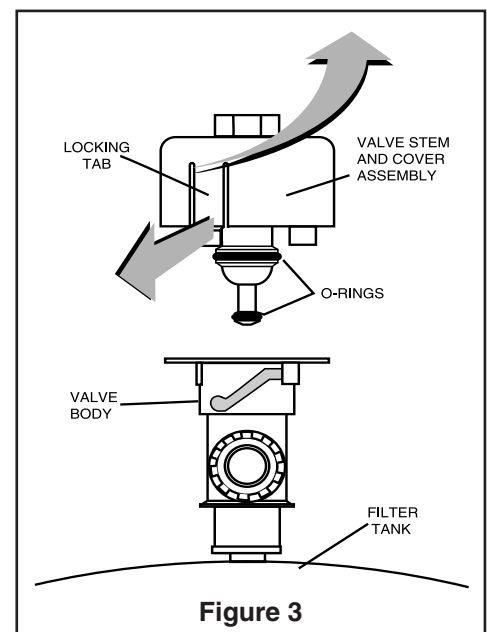

**Figure 3**



## TROUBLESHOOTING

---

- A. Air entering your filter is dangerous and can cause the lid to separate from the tank body. Correct any conditions in your filtration system that allow air to enter the system.
1. Some common ways to identify air entering the system:
    - a. Low water level in pool or spa - skimmer is starving for water with pump running. Add water to pool or spa.
    - b. Air bubbles or low water level in pump hair and lint pot are caused by; low water level, clogged skimmer basket, split suction cleaner hose, leak in pump hair and lint pot lid, or leak in pump suction line.
    - c. Air bubbles coming out of water return lines into pool or spa with pump running, see items 1.a and 1.b of this section.
    - d. Air is discharged from the air relief valve on top of the filter when the valve is opened with the pump running, see items 1.a and 1.b of this section, above.
- B. If the D.E. is returning back to the pool upon backwashing, check to make sure the bag is seated properly on the separation bag ring. Also check the bag to see if it is torn or missing. If the bag is torn, a replacement is needed.
- C. The pressure gauge is an important part of the separation tank. It is your primary indicator of how the system is operating. Maintain your pressure gauge in good working order. Check the operation of your pressure gauge in the following manner:
1. The pressure gauge should go to zero (0) when the system is turned off and pressure is relieved.
  2. The pressure gauge should indicate pressure when the system is operating.
  3. The pressure gauge should be readable and not damaged in any way.
  4. Replace the pressure gauge immediately if it fails to meet any of the requirements above.

# REPLACEMENT PARTS

Item	Part #	Description
1	98209800	High Flow Manual Air Relief Valve
2	190058	Pressure Gauge
3	310010Z	Tank Lid, Almond
	310015	Tank Lid, Black
4	59052900	Locking Ring Assembly
5	87300400	Body O-ring
6	170099	Separation Bag
7	310004	Separation Bag Retaining Ring
8	178731Z	Tank Bottom, Almond
	178743Z	Tank Bottom, Black
9	154712	Drain Cap Assembly
10	178732Z	Union Nut "C" Clip
11	U11-200PS	Union, Nut
12	178746Z	Union, Diamond Seal
13	178733Z	Union, Threaded Half

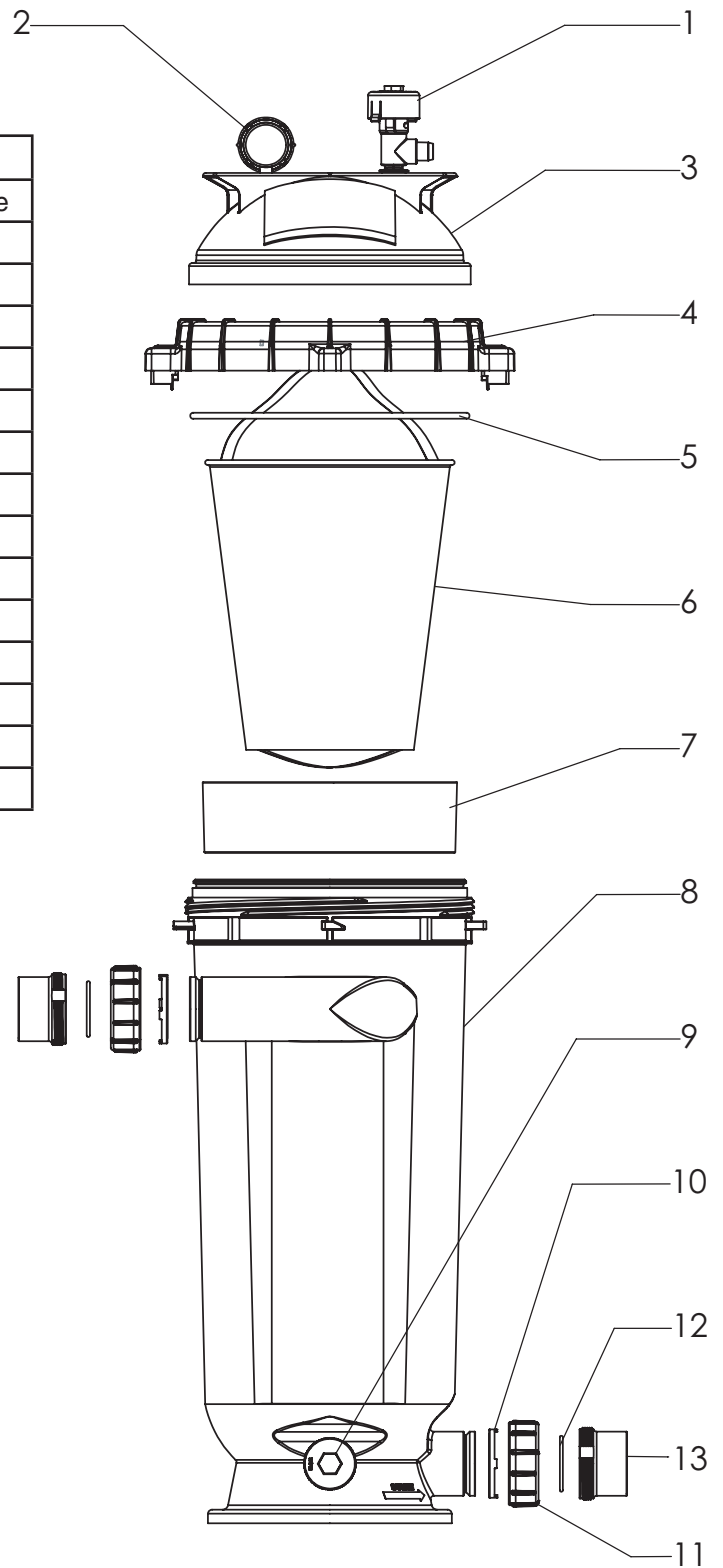



# SAVE THESE INSTRUCTIONS



1620 HAWKINS AVE., SANFORD, NC 27330 • (919) 566-8000  
10951 WEST LOS ANGELES AVE., MOORPARK, CA 93021 • (805) 553-5000

All indicated Pentair trademarks and logos are property of Pentair. Third party registered and unregistered trademarks and logos are the property of their respective owners.

© 2023 Pentair. All rights reserved. [WWW.PENTAIR.COM](http://WWW.PENTAIR.COM)



P/N 310006 REV. C 11/13/23