

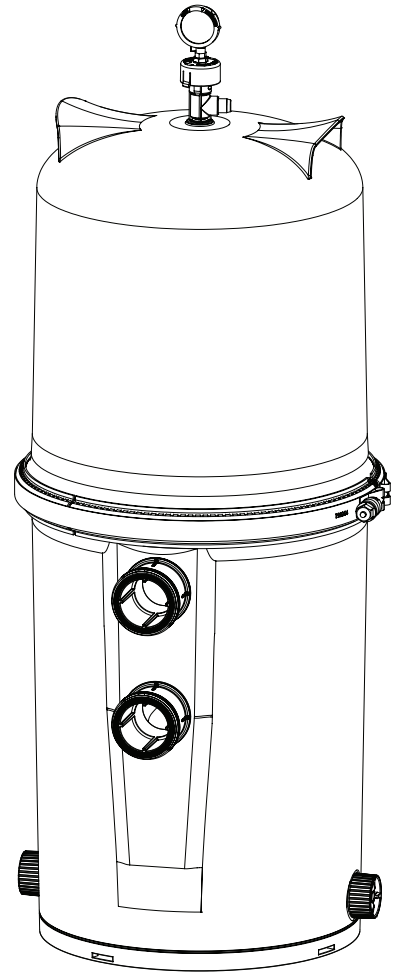

FULLFLOXF[®] Q-SERIES

CARTRIDGE STYLE D.E. FILTER

INSTALLATION AND USER'S GUIDE



IMPORTANT SAFETY INSTRUCTIONS
READ AND FOLLOW ALL INSTRUCTIONS
SAVE THESE INSTRUCTIONS

⚠ WARNING



Pressurized air can cause the lid to separate from the tank with great force. To reduce the risk of severe injury or death, relieve pressure by opening air relief valve before opening filter. Before starting the pump after servicing, ensure that clamp band is correctly fastened. Read and understand all of the following safety, installation and operation instructions before installing, operating or servicing the filter.

IMPORTANT SAFETY INSTRUCTIONS



Important Notice:

This guide provides installation and operation instructions for this product. Consult Pentair with any questions regarding this equipment.

Attention Installer: This guide contains important information about the installation, operation and safe use of this product. This information should be given to the owner and/or operator of this equipment after installation or left on or near the filter.

Attention User: This manual contains important information that will help you in operating and maintaining this filter. Please retain it for future reference.

READ AND FOLLOW ALL INSTRUCTIONS SAVE THESE INSTRUCTIONS



This is the safety alert symbol. When you see this symbol on your system or in this manual, look for one of the following signal words and be alert to the potential for personal injury.



DANGER Warns about hazards that can cause death, serious personal injury, or major property damage if ignored.



WARNING Warns about hazards that may cause death, serious personal injury, or major property damage if ignored.



CAUTION Warns about hazards that may or can cause minor personal injury or property damage if ignored.

NOTE Indicates special instructions not related to hazards.

Carefully read and follow all safety instructions in this manual and on equipment. Keep safety labels in good condition; replace if missing or damaged.



Before installing this product, read and follow all warning notices and instructions which are included.

Failure to follow safety warnings and instructions can result in severe injury, death, or property damage. Call (800) 831-7133 for additional free copies of these instructions.

Consumer Information and Safety

This filter is designed and manufactured to provide many years of safe and reliable service when installed, operated and maintained according to the information in this manual and the installation codes referred to in later sections. Throughout the manual, safety warnings and cautions are identified by the “” symbol. Be sure to read and comply with all of the warnings and cautions.



Do not operate the filter until you have read and understand clearly all the operating instructions and warning messages for all equipment that is a part of the pool circulating system. The following instructions are intended as a guide for initially operating the filter in a general pool installation, however each installation may have unique conditions where the starting procedure could be different. Failure to follow all operating instructions and warning messages can result in severe injury, death, or property damage.



Do not permit children to use or operate this filter.



Use only a PTFE or silicone based lubricant when lubricating the O-rings on the union and bulkhead couplings. Use of petroleum based products will damage the equipment.



FILTER OPERATES UNDER HIGH PRESSURE.



When any part of the circulating system, (e.g., clamp, pump, filter, valve(s), etc.), is serviced, air can enter the system and become pressurized. Pressurized air can cause the lid to separate which can result in severe injury, death, or property damage.

To avoid this potential hazard, follow these instructions:

1. Before repositioning valve(s) and before beginning the assembly, disassembly, or adjustment of the clamp or any other service of the circulating system: (A) Turn the pump **OFF** and **shut OFF** any automatic controls to ensure the system is NOT inadvertently started during the servicing; (B) open the manual air relief valve; (C) stand clear of the filter; (D) wait until all pressure is relieved.
2. Whenever installing the filter clamp **FOLLOW THE FILTER CLAMP INSTALLATION INSTRUCTIONS EXACTLY.**
3. Once service on the circulating system is complete **FOLLOW SYSTEM RESTART INSTRUCTIONS EXACTLY.**
4. Maintain circulation system properly. Replace worn or damaged parts immediately, (e.g., clamp, pressure gauge, valve(s), o-rings, etc).
5. Be sure that the filter is properly mounted and positioned according to instructions provided.



Due to the potential risk that can be involved it is recommended that the pressure test be kept to the minimum time required by the local code. Do not allow people to work around the system when the circulation system is under pressure test. Post appropriate warning signs and establish a barrier around the pressurized equipment. If the equipment is located in an equipment room, lock the door and post a warning sign.

Never attempt to adjust any closures or lids or attempt to remove or tighten bolts when the system is pressurized. These actions can result in a separation or failure of system components. This instantaneous release of energy can cause components to be accelerated to high velocities and to travel far distances. These components could cause severe personal injury or death if they were to strike a person.



Never exceed the maximum operating pressure of the system components. Exceeding these limits could result in a component failing under pressure. This instantaneous release of energy can cause the closure to separate and could cause severe personal injury or death if they were to strike a person.



RISK OF ELECTRICAL SHOCK OR ELECTROCUTION. This filter must be installed by a qualified service professional in accordance with the National Electrical Code and all applicable local codes and ordinances.

Always disconnect power to the equipment at the circuit breaker before servicing any of the equipment. Ensure that the disconnected circuit is locked out or properly tagged so that it cannot be switched on while you are working on the pool equipment. Failure to do so could result in serious injury or death to serviceman, pool users or others due to electric shock.

Position the filter and the air relief valve to safely direct water drainage and purged air or water. Water discharged from an improperly positioned filter or valve can create an electrical hazard that can cause severe personal injury as well as damage property.

IMPORTANT SAFETY INSTRUCTIONS

⚠️ WARNING

This filter is intended for use in swimming pool applications. Most states and local codes regulate the construction, installation, and operation of public pools and spas, and the construction of residential pools and spas. It is important to comply with these codes, many of which directly regulate the installation and use of this product. Consult your local building and health codes for more information.

⚠️ DANGER

SERIOUS BODILY INJURY OR DEATH CAN RESULT IF THIS FILTER IS NOT INSTALLED AND USED CORRECTLY.

⚠️ DANGER

INSTALLERS, POOL OPERATORS AND POOL OWNERS MUST READ THESE WARNINGS AND ALL INSTRUCTIONS BEFORE USING THIS FILTER.

⚠️ DANGER

HAZARDOUS PRESSURE: STAND CLEAR OF PUMP AND FILTER DURING START UP



Circulation systems operate under high pressure. When any part of the circulating system (i.e. locking ring, pump, filter, valves, etc.) is serviced, air can enter the system and become

pressurized. Pressurized air can cause the pump housing cover filter lid and valves to violently separate which can result in severe personal injury or death. Filter tank lid and strainer cover must be properly secured to prevent violent separation. Stand clear of all circulation system equipment when turning on or starting up pump.

Before servicing equipment, make note of the filter pressure. Be sure that all controls are set to ensure the system cannot inadvertently start during service. Turn off all power to the pump. **IMPORTANT: Place filter manual air relief valve in the open position and wait for all pressure in the system to be relieved.**

Before starting the system, fully open the manual air relief valve and place all system valves in the "open" position to allow water to flow freely from the tank and back to the tank. Stand clear of all equipment and start the pump.

IMPORTANT: Do not close filter manual air relief valve until all pressure has been discharged from the valve and a steady stream of water appears. Observe filter pressure gauge and be sure it is not higher than the pre-service condition.

⚠️ CAUTION



For Installation of Electrical Controls at Equipment Pad (ON/OFF Switches, Timers and Automation Load Center) Install all electrical controls at equipment pad, such as on/off switches, timers, and control systems, etc. to allow the operation (startup, shut-down, or servicing) of any

pump or filter so the user does not place any portion of his/her body over or near the pump strainer lid, filter lid or valve closures.

This installation should allow the user enough space to stand clear of the filter and pump during system start-up, shut down or servicing of the system filter.

⚠️ CAUTION

The following information should be read carefully since it outlines the proper manner of care and operation for your filter system. As a result of following these instructions and taking the necessary preventative care, you can expect maximum efficiency and life from your filtration system.

General Installation Information

The following information should be read carefully since it outlines the proper manner of care and operation for your filter system.

You can expect maximum efficiency and life from your filtration system by following these instructions and taking the necessary preventative care.

- Have a trained pool professional perform all pressure tests.
- Do not connect the system to a high pressure or city water system.
- Trapped air in the system can create a hazardous condition. BE SURE to purge all air from the system before operating or testing equipment.
- DO NOT pressure test with compressed air!
- Piping must conform to local/state plumbing and sanitary codes.
- Support piping independently to prevent strains on filter or valve.
- Fittings restrict flow; for best efficiency, use the fewest possible fittings.
- A check valve installed ahead of the filter inlet will prevent contaminants from draining back into the pool.
- A check valve installed between the filter and heater will prevent hot water from backing up into the filter and deforming the internal components.
- All wiring, grounding and bonding of associated equipment must meet local and/or National Electrical Code standards.
- Only a qualified plumbing professional should install this filter.

IMPORTANT: Keep all warning labels in good condition. If any warnings labels are damaged, missing, or become illegible call Pentair Customer Service at 1-800-831-7133 and request replacement labeling.

CUSTOMER SERVICE / TECHNICAL SUPPORT

Hours: 9:00AM to 7:00PM EST (6:00AM - 4:00PM PST)

Call: (800) 831-7133

Visit: www.pentair.com

Fax: (800) 284-4151

TABLE OF CONTENTS

IMPORTANT SAFETY INSTRUCTIONS	ii	MAINTENANCE	9
GENERAL INFORMATION	1	When to Clean the Filter	9
Filter Overview	1	Backwashing the Filter	9
General Operation Information	1	Manually Cleaning the Filter Cartridges	10
Maintaining the Pressure Gauge	1	Acid Soaking the Filter Cartridges	11
Pressure Tests	1	Replacing Filter Cartridges	12
INSTALLATION	2	Cleaning the Manual Air Relief Valve	12
Filter Location	2	TROUBLESHOOTING	13
Filter Plumbing	2	TECHNICAL DATA	14
Installing the Manual Air Relief Valve	3	Dimensional Drawings	14
Anchor Clamp Installation	4	Head Loss Comparison Curve	14
SYSTEM START-UP AND OPERATION	5	Recommended Flow Rates	14
Opening the Filter	5	REPLACEMENT PARTS	15
Preparing Diatomaceous Earth (D.E.)	6		
Coating the Filter Cartridges with D.E.	6		
Installing the Filter Lid and Clamp Ring	7		
Start-Up Instructions	8		

GENERAL INFORMATION

WARNING



THIS SYSTEM OPERATES UNDER HIGH PRESSURE.

When any part of the circulating system (e.g., Lock Ring, Pump, Filter, Valves, etc.) is serviced, air can enter the system and become pressurized. Pressurized air can cause the lid to separate which can result in serious injury, death, or property damage. To avoid this potential hazard, follow the instructions below.

Filter Overview

1. Four easily removable, large-capacity cartridges provide maximum filter surface area for greater dirt-trapping capacity and longer periods between cleanings.
2. Full 2-1/2" x 3" bulkhead unions for improved hydraulic efficiency and easy piping installation.
3. HiFlow™ Manual Air Relief Valve for rapid air release.
4. Conveniently located 2" drain for easy and complete draining.
5. Durable 8 oz. polypropylene cartridge media has superslick surfaces, making them easier to clean than conventional cartridge filters.

General Operation Information

Read and follow all instructions and warnings before installing or servicing your filter. Proper installation and operation can prevent unnecessary repairs and maintenance.

WARNING



Your filter is a piece of machinery, do not tamper with it, attempt to disassemble it or otherwise adjust it unless you fully understand it's operation. Serious injury or death can occur if the equipment is improperly handled. Consult a pool service professional for maintenance and service assistance.

1. This filter operates under pressure. When clamped properly and operated without air in the water system, this filter will operate in a safe manner.
2. The maximum working pressure of this filter is 50 psi. Never subject this filter to pressure in excess of this amount - even when conducting hydrostatic pressure tests.
3. Ensure the maximum working pressure of the filter system does not exceed the maximum working pressure of any components within the system during hydrostatic or external leak tests. Consult the maximum pressure stated on each component of the system.
4. The pressure gauge is the primary indicator of how the filter is operating. Maintain your pressure gauge in good working order according to *Maintaining the Pressure Gauge*.
5. Never operate filter in excess of three minutes without use of diatomaceous earth. Diatomaceous earth is the substance that filters the water, the filter cloth merely supports the diatomaceous earth. Operating without diatomaceous earth will damage filter cartridges and shorten filtering cycles.

Maintaining the Pressure Gauge

The Pressure Gauge (P/N 190058) is the primary indicator of how the system operates. It is critical to keep the pressure gauge in good condition.

Replace pressure gauge if any of the requirements below are not met:

- Pressure gauge at zero (0) when pressure is relieved and system is turned off.
- Pressure gauge reads correctly while system is in operation.
- The pressure gauge is readable and not damaged in any way.

Pressure Tests

When performing hydrostatic pressure tests or when testing for external leaks of the completed filtration and plumbing system, ensure that the Maximum Pressure that the filtration system will be subjected to **DOES NOT EXCEED THE MAXIMUM WORKING PRESSURE OF ANY OF THE COMPONENTS CONTAINED WITHIN THE SYSTEM.**

In most cases, the maximum pressure will be stated on each component of the system. If doubt exists as to the pressure to which the system will be subjected, install an ASME approved automatic Pressure Relief or Pressure Regulator in the circulation system set to the lowest working pressure of all of the components in the system.

INSTALLATION

The following information describes how to install the FullFloXF® Q-Series Cartridge Style D.E. Filter. Only a qualified service person should install this filter.

Before installing this product, read and follow all warning notices and instructions on pages i-ii.

Filter Location

1. The filter should be mounted on a level concrete slab. Position the filter so that instructions, warnings and the pressure gauge are visible to the operator.
2. Position the filter so that the piping connections, control valve and drain port are convenient and accessible for servicing and winterizing.
3. Install electrical controls (e.g., on/off switches, timers, control systems, etc.) at least 5 ft. (1.5 m) from the filter. This will allow you enough room to stand clear of the filter during system start up.
4. Allow sufficient clearance around the filter to permit visual verification that the clamp ring is properly installed around the tank flanges, see **Figure 1**
Note: Refer to Anchor Clamp Installation, page 4 for instructions on properly installing the clamp ring.
5. Provide 6.7 ft. (2.1 m) of vertical clearance above the filter to remove the filter lid for cleaning and servicing.
6. Position the filter to safely direct water drainage. Rotate the Manual Air Relief Valve to safely direct purged air or water. Water discharged from an improperly positioned filter or valve can create an electrical hazard as well as damage property.

⚠ WARNING



RISK OF ELECTRICAL SHOCK OR ELECTROCUTION. Position the filter and manual air relief valve to safely direct water drainage and purged air or water. Water discharged from an improperly positioned filter or valve can create an electrical hazard that can cause severe personal injury as well as damage property.

7. Install the manual air relief valve and pressure gauge before use. See *Installing the Manual Air Relief Valve*, page 3.

Filter Plumbing

1. Make all plumbing connections in accordance with local plumbing and building codes. Check local codes for restrictions on backwash to waste piping, separation tank requirements and spent D.E. disposal requirements.
2. Filter plumbing connections are provided with an O-ring seal. To avoid damage to the O-rings, use only a silicone base lubricant on the O-rings. Do not use pipe joint compound, glue or solvent on the bulkhead connections.

⚠ CAUTION

This D.E. filter has a different water flow pattern than all other Pentair D.E. filters. When plumbing the filter with a backwash valve, one of the following valves, listed below, must be used. Failure to use the correct backwash valve could damage the filter cartridges and void the warranty.

3. This filter requires one of the following Pentair accessories which must be purchased separately.
 - a. P/N 262511 - FullFloXF Valve (Recommended)
 - b. P/N 410020 - Union Kit

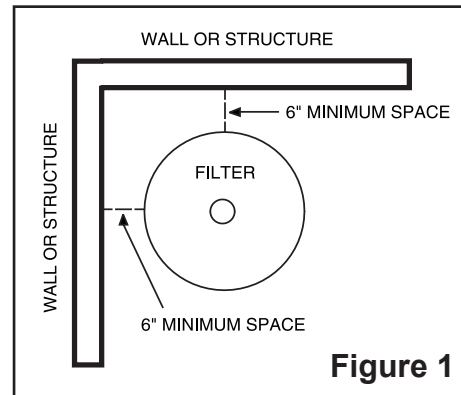

Figure 1

Installing the Manual Air Relief Valve

WARNING The manual air relief valve and pressure gauge are included with this filter to help ensure safe operation of the equipment. Always maintain these components in good working condition.

1. Remove the Manual Air Relief Valve and the pressure gauge from the accessories package included with your FullFloXF® Q-Series Cartridge Style D.E. Filter.
2. Thread the manual air relief valve into the threaded hole at the top of the filter tank.
Note: Hand tighten only! Over tightening the valve can cause damage to the tank or valve connection threads.
3. Verify that the valve is positioned to safely direct purged air or water away from electrical equipment or anything that might be damaged.

WARNING RISK OF ELECTRICAL SHOCK OR ELECTROCUTION. Water discharged from an improperly positioned filter or valve can create an electrical hazard that can cause severe personal injury as well as damage property.

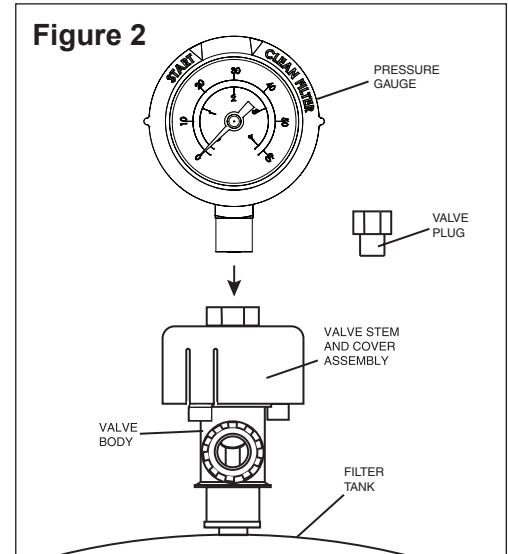

4. Remove the plug from the top of the manual air relief valve with a 9/16" wrench.
5. Wrap the pressure gauge connection threads with thread seal tape (two full wraps of tape will be enough).
6. Thread the pressure gauge into the top of the manual air relief valve. **Hand tighten only!**
7. Follow *Start-Up Instructions, page 8*.

Anchor Clamp Installation

Installation of anchor clamps is recommended in high wind and seismically active areas. A Pentair Anchor Clamp Kit (P/N 178840) is not included with this filter, but can be purchased separately.

Anchor clamps hold the FullFloXF® Q-Series Cartridge Style D.E. Filter to the equipment pad in order to withstand high winds caused during extreme weather, such as hurricanes.

To install the anchor clamps:

1. Be sure the filter is in its permanent location on the equipment pad.
2. Place the clamps into the base of the filter in the four anchor slots shown in **Figure 3**.

Note: Bolts and bolt anchors are not included with the filter. The installer must provide 1/4" x 1-3/8" stainless steel anchor bolts and the appropriate size concrete anchor to mount the clamp to the equipment pad. Be sure to check local codes.

3. Fit the hook of each clamp into the anchor slots on the base panel of the filter. See **Figure 3**.
4. Mark the position of the hole in each clamp on the equipment pad.
5. Use a masonry drill bit and drill a hole in the cement with a diameter as determined by the concrete anchor, at each of the marks on the equipment pad. The hole should be approximately 1.5 inches deep. See **Figure 4**.
6. Insert a bolt anchor into each of the holes. Be sure the anchors are set completely into the holes.
7. Position the anchor clamps so that the holes in the clamps are over the bolt anchors. Be sure that the clamp hooks are over the lip of the filter base.
8. Insert an anchor bolt through each clamp into the bolt anchor and tighten to secure the clamp and filter to the equipment pad.

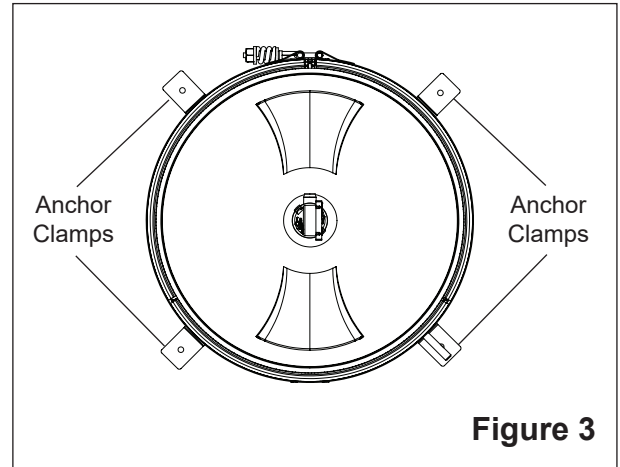

Figure 3

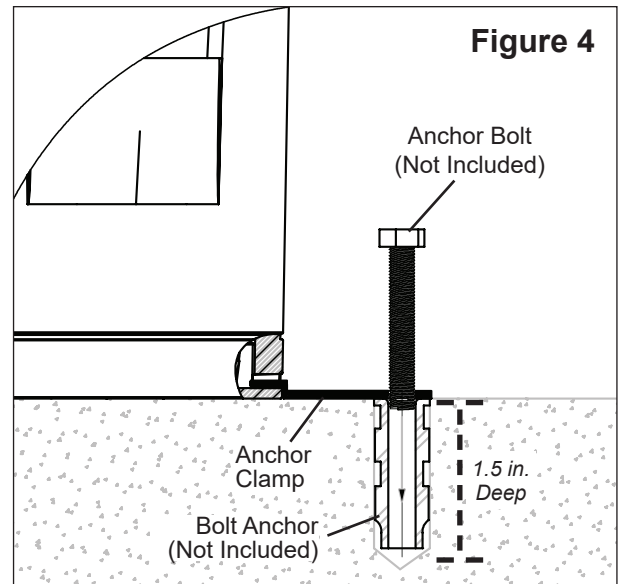

Figure 4

SYSTEM START-UP AND OPERATION



The following information outlines the proper manner of care and operation for your filter system. Follow these instructions to ensure the maximum efficiency and lifespan of your filtration system.

Opening the Filter

Follow these instructions **exactly** to prevent the lid from separating during system start-up, operation or servicing.



FILTER OPERATES UNDER HIGH PRESSURE.



When any part of the circulating system (e.g., Clamp Ring, Pump, Filter, Valves, etc.) is serviced, air can enter the system and become pressurized. Pressurized air can cause the lid to separate which can result in serious injury, death, or property damage. To avoid this potential hazard, follow the instructions below.

REQUIRED TOOLS:

- Ratchet Wrench
- 7/8" Socket
- Socket Extender (if needed)

PROCEDURE:

1. Shut off pump and relieve pressure.
 - a. Turn the pump OFF, shut OFF any automatic controls (e.g., timers), and disconnect power to ensure that the system is not inadvertently started during maintenance.
 - b. Open the Manual Air Relief Valve by turning the valve cover assembly counter-clockwise until it snaps into the full open position.
 - c. Stand clear of the filter and wait until all pressure is relieved. Pressure gauge must read zero (0 psi).
2. Open the waste drain plug on the bottom of the FullFloXF® Q-Series Cartridge Style D.E. Filter. Allow all water to drain from the bottom of the filter tank.
3. Loosen the clamp's barrel nut with a 7/8" wrench, allowing the spring coils to decompress. See **Figure 6**. Remove the barrel nut, spring and two washers from the T-bolt and place them in a safe place where they will not be lost.
4. Once the spring has fully decompressed the clamp assembly will rest in the open position. Carefully lift the filter lid straight up from the lower body of the filter. If the lid is tightly sealed to the filter body you may have to gently push the filter lid from side to side in order to separate the lid from the tank bottom.

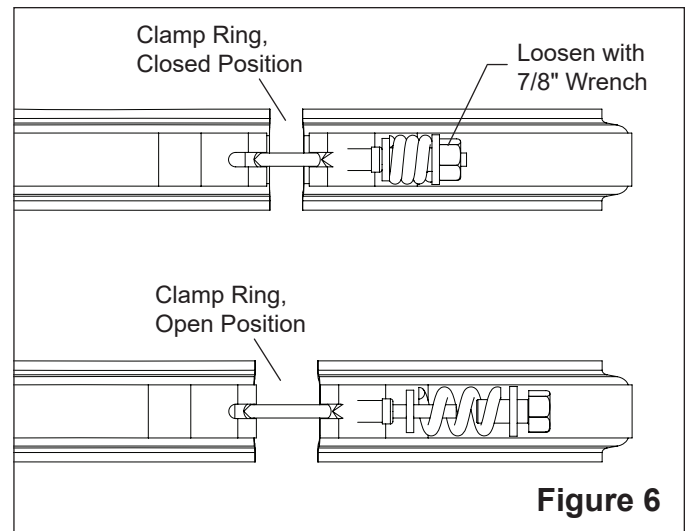
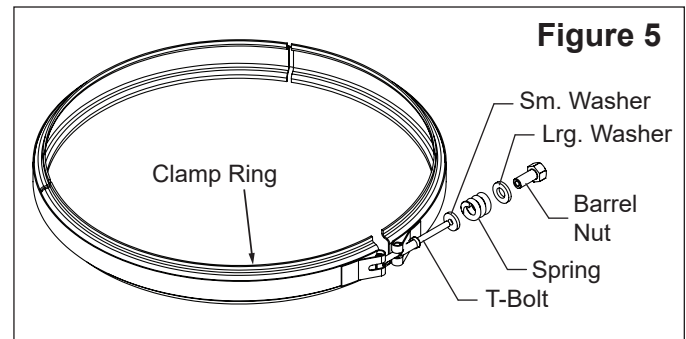

DO NOT use the pressure relief valve as a handle or lever since this may damage the valve.

5. Place the tank lid in a safe place where it will not be damaged while performing any maintenance.

Note: Attempt to minimize the amount of debris that comes in contact with the tank O-ring while it is exposed. This will help prolong the life of the O-ring.

Preparing Diatomaceous Earth (D.E.)



Follow all manufacturer safety precautions given on the D.E. packaging.

The filter requires 12 lbs. (5.5 kg), or 24 1-lb. coffee cans, of diatomaceous earth (D.E.) to provide proper filtration and operation. Your filter cartridges must be precoated with this material in order to protect their surfaces and provide the most efficient filtering action.

Pentair recommends using D.E. intended for use with swimming pools and spas. These grades of D.E. typically have a median particle size of 34 microns, which is ideal for most applications.

1. The filters are listed with the appropriate amounts of D.E. to be used to precoat the filter cartridges. A 1-lb. coffee can filled (level) with D.E. is equal to 1/2-lb. weight of diatomaceous earth. Do not “pack” or compress D.E. into the coffee can.
2. Mix the required amount of D.E. with sufficient water in a bucket to make a thin, milky mixture.
3. Refer to *Coating the Filter Cartridges with D.E.* when introducing the D.E. slurry into the filter.

Coating the Filter Cartridges with D.E.



The following information outlines the proper manner of care and operation for your filter system. Follow these instructions to ensure the maximum efficiency and lifespan of your filtration system.

1. Position valve to FILTER OR VACUUM TO POOL setting. This is your normal flow from the pump through the filter to the pool. Open the Manual Air Relief Valve on the filter.
2. Prepare the recommended amount of diatomaceous earth according to instructions given in *Preparing Diatomaceous Earth (D.E.)*.
3. On initial start-up the pump must be primed by filling the hair and lint strainer pot with water. You may have to do this several times.
4. Follow the steps outlined on page 8, *Start-Up Instructions* for system start-up.
5. Introduce the slurry of D.E. from the bucket directly into the top of the skimmer. With the pump running and the pool skimmer valve open, pour the mixture directly into the skimmer. The slurry will be drawn into the filter.
6. Your filter is now operational.

Installing the Filter Lid and Clamp Ring

⚠ WARNING



Follow these instructions **exactly** to prevent the lid from separating from the filter during system start-up or operation. (See Important Safety Instructions, page i-ii).

REQUIRED TOOLS:

- Ratchet Wrench
- 7/8" Socket
- Socket Extender (if needed)
- Rubber Mallet

PROCEDURE:

1. Ensure the O-ring is clean and in position in the lower tank half. Press the FullFloXF® Q-Series Cartridge Style D.E. Filter lid onto the lower half so the O-ring fits in between the tank halves.
 2. Hold the ends of the clamp ring apart and place over both upper and lower tank flanges. Bring the ends of the clamp ring together.
 3. Insert the T-bolt through the other side of the clamp ring and hold together.
 4. Place the small washer onto the T-bolt.
 5. Place the spring, large washer and barrel nut onto the T-bolt and tighten the nut by hand. Be sure the clamp ring fits easily on the tank flanges.
 6. After tightening by hand:
 - a. Use a 7/8 in. wrench (ratchet wrench recommended) to tighten further.
 - b. Tap around the outside of the clamp ring with a rubber mallet (or similar tool) multiple times around the entire clamp ring to fit the clamp ring properly.
 - c. Continue to tighten until the spring coils touch.
 - d. Tap around the entire clamp ring again and verify the spring coils remain touching. If not, continue to tighten the nut.
- Note:** The clamp ring is installed correctly only when the spring coils remain touching after tapping the clamp ring see **Figure 7**.
7. Close the waste drain plug at the bottom of the filter.
 8. Follow Start-Up Instructions exactly (see page 8).

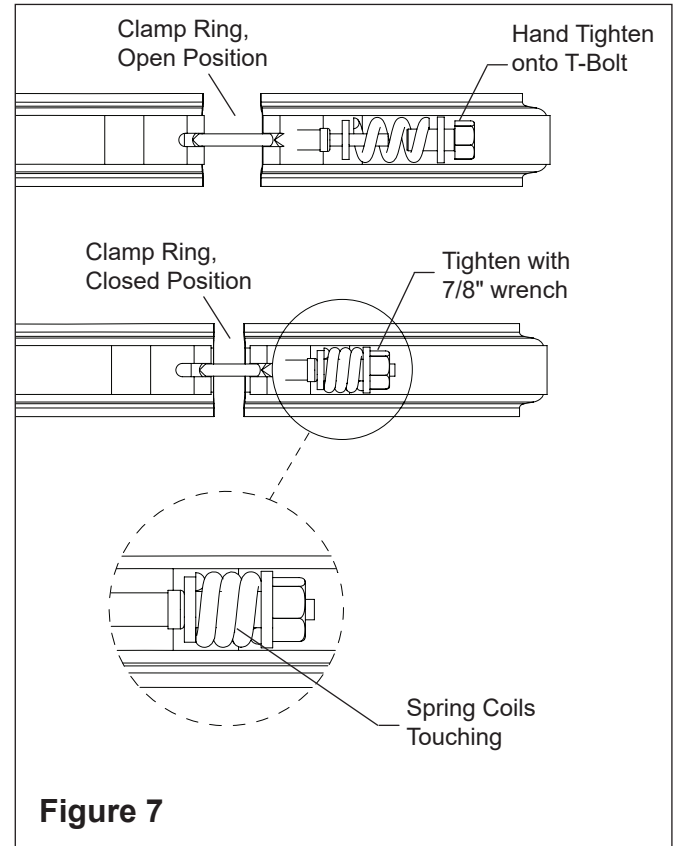

Figure 7

Note: Check the spring coils at least once a month to ensure proper tension. If spring coils do not touch then shut off pump and relieve pressure and tighten the nut and tap filter clamp ring until the coils touch.

⚠ WARNING



DO NOT tighten the clamp nut or attempt to adjust the clamp ring or lid while the filtration system operating or under pressure. This could cause the lid to separate from the filter.

Start-Up Instructions

WARNING



THIS FILTER OPERATES UNDER HIGH PRESSURE.

WHEN ANY PART OF THE CIRCULATING SYSTEM, (e.g., clamp, pump, filter, valve(s), etc.), is serviced, air can enter the system and become pressurized. Pressurized air can cause the lid to separate which can result in severe injury, death, or property damage. To avoid this potential hazard, follow these instructions:

1. Ensure the **spring on the clamp ring is fully compressed, with coils touching.**
2. Open the Manual Air Relief Valve by turning the valve cover assembly a quarter turn counter-clockwise, until it snaps into the full open position. See **Figure 8.**
3. Stand clear of the filter tank, then start the pump.
4. Watch for proper operation. The system is not working properly if:
 - a. The pressure gauge indicates pressure before water out-flow appears.
 - b. A solid stream of water does not appear within 30 seconds after the pump's inlet basket fills with water.
 - c. Water leaks from where the two halves of the filter come together.

If any of these conditions exist, **shut off the pump immediately.** Open the manual air relief valve to relieve pressure and clean the valve (see *Cleaning the Manual Air Relief Valve*, page 12). If the problem persists, call Pentair Technical Service at (800) 831-7133 for assistance.
5. After a steady stream of water appears, close the manual air relief valve by turning the valve cover assembly a quarter turn clockwise.
6. The first time the system is started up, fill out **Table 1:**
 - a. Record the "Original Starting Pressure"
 - b. Fill in the pressure at which to clean the filter (8-10 psi higher than the "Original Starting Pressure").
 - c. If the system includes a variable speed pump, record "Original Pump RPM". "Original Starting Pressure" will be dependent on the pump speed (RPM).

Quarter turn counter-clockwise to open

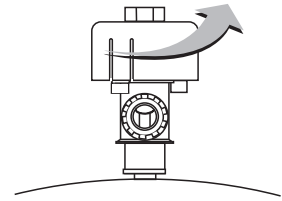

Closed Position

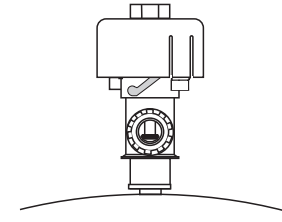

Open Position

Figure 8

Table 1

ORIGINAL STARTING PRESSURE IS: _____ psi.
(pounds per square inch)

SERVICE THE MEDIA AT: _____ psi.

ORIGINAL PUMP RPM: _____ rpm.
(for Variable Speed Pumps Only)

MAINTENANCE

⚠ WARNING



FILTER OPERATES UNDER HIGH PRESSURE.

When any part of the circulating system, (e.g., clamp, pump, filter, valve(s), etc.), is serviced, air can enter the system and become pressurized. Pressurized air can cause the lid to separate which can result in severe injury, death, or property damage.

To avoid this potential hazard, follow these instructions:

1. Before repositioning valve(s) and before beginning the assembly, disassembly, or adjustment of the clamp or any other service of the circulating system: (A) Turn the pump OFF and shut OFF any automatic controls to ensure the system is NOT inadvertently started during the servicing; (B) open the manual air relief valve; (C) stand clear of the filter; (D) wait until all pressure is relieved.
2. Whenever installing the filter clamp FOLLOW THE FILTER CLAMP INSTALLATION INSTRUCTIONS EXACTLY.
3. Once service on the circulating system is complete FOLLOW SYSTEM RESTART INSTRUCTIONS EXACTLY.
4. Maintain circulation system properly. Replace worn or damaged parts immediately, (e.g., clamp, pressure gauge, valve(s), O-rings, etc).
5. Be sure that the filter is properly mounted and positioned according to instructions provided.

⚠ WARNING

Operating the filter system without filter internal components installed can allow air to accumulate within the filter. Pressurized air can cause the lid to separate which can result in severe injury, death or property damage. Always operate filter system with filter internal components installed. To prevent equipment damage and possible bodily injury and/or property damage, always turn the pump off before changing the valve positions.

⚠ WARNING

Please follow all manufacturers' posted instructions, warnings and cautions when using pool or spa sanitizers, and/or other chlorine replacement treatments.

When to Clean the Filter

Properly monitoring and cleaning the filter will prevent avoidable repairs and maintenance.

Clean your filter when pressure reads between 8-10 psi higher than the "Original Starting Pressure" recorded in **Table 1** on the previous page, or when significant reduction in flow is noticed. The pressure reading increases as it filters dirt from your pool. This build up of pressure will vary due to different bathing loads, temperature, environmental conditions, etc.

Backwashing the Filter

Most effective cleaning of the filter cartridges requires disassembly and hand cleaning. However, for convenience and to extend the interval between cleanings, the FullFloXF® Q-Series Cartridge Style D.E. Filter can be equipped with an external backwash valve.

1. Turn the entire pool/spa system off at the circuit breaker.
2. Open the Manual Air Relief Valve and wait until all pressure is released from the system. Never attempt to assemble, disassemble or adjust the filter clamp while there is pressure in the filter.
3. Turn skimmer to full skim position and close main drain line.
4. Remove pump lid and clean basket. Replace the basket and secure lid.
5. Position the valve to BACKWASH.
6. Open the manual air relief valve until it snaps into the full open position to release trapped air in the filter (this only requires a quarter turn counter-clockwise).
7. Stand clear of the tank, then start the pump.
8. Close the manual air relief valve after a steady stream of water appears.

9. When water flows clear in the sight glass or discharge line, shut the pump off. This should take about three minutes.

Note: Backwashing is most effective when the filter is operated at the maximum listed flow rate.

10. If the filtration system includes a separation tank, refer to the the separation tank's manual for instructions on cleaning the tank.
11. Rotate the valve handle back to FILTER.
12. Restart system, refer to *Start-Up Instructions*, page 8.
13. Proceed with operation and precoat filter with the required amount of D.E.
Refer to *Preparing Diatomaceous Earth (D.E.)*, page 6..

NOTE: If the starting pressure after backwashing the filter or cleaning the cartridges indicates 8 to 10 psi higher than the original starting pressure as defined in Table 1 on page 8, the filter cartridges must be manually cleaned. Refer to Manually Cleaning the Filter Cartridges on page 10 for instructions.

NOTE: Filter waste and D.E. are trapped by the heavy-duty double lined Separation Tank bag. Contents are to be placed in a waste or trash container, clean the bag and re-insert in the Separation Tank. **DO NOT LEAVE THE TANK BAG EXPOSED IN THE SUN.** The manufacturer cannot assume any responsibility for torn, or damaged bags, if left in the sun to dry.

Manually Cleaning the Filter Cartridges

1. Backwash the filter by following Backwashing the Filter on page 9.
2. Follow Opening the Filter (page 5) exactly.

Note: If the filtration system includes a separation tank, close all other valves and remove the drain plug from the backwash line.

3. Remove hair and lint strainer pot lid from the pump and clean basket. Replace strainer basket and secure strainer pot lid.
4. Remove the Air Bleed Screen Cap (1) from the Top Manifold (2). See **Figure 9**.
5. Clean all debris from the Air Bleed Screen Cap and reinstall onto the top manifold.
6. Separate the Top Manifold (2) from the filter cartridges and lay the manifold to the side. See **Figure 9**.
7. Carefully remove each cartridge separately.
8. Using a garden hose with a straight flow nozzle, wash down the entire filter cartridge. Wash from the top down, holding the nozzle at a 45-degree angle to the cartridge (see **Figure 10**). Pay special attention to the area between pleats.
9. For cartridges used in pools or spas where high levels of perspiration, suntan lotions and other oils are present:
 - a. Soak the cartridge for at least one hour (overnight is most effective) in one of the following:

- A commercial filter cleaner



WARNING Heed all manufacturers' instructions and warnings when using polyhexamethylene biguanide sanitizers or other cartridge filter cleaner solutions.

- 1 cup trisodium phosphate (TSP) to 5 gallons of water
- 1 cup dishwasher detergent to 5 gallons of water

- b. Rinse the cartridge to remove oils and cleaning solution.



CAUTION Failure to remove all oils and cleaning solutions before acid soaking will result in permanent restriction of water flow through the filter and will cause premature cartridge failure.

10. Direct the water spray to wash out the inside of the tank body and bottom manifold. Water and debris will drain out through the open drain plug.

Note: If the filtration system includes a separation tank, reinstall the drain plug into the backwash line.

11. Place the four cartridges back onto the support pipes in the bottom of the tank.
12. Reinstall the Top Manifold (2) onto the cartridges and verify the Air Bleed Screen Cap (1) and O-Ring (3) are secured to the manifold. See **Figure 9**.
13. Follow *Installing the Filter Lid and Clamp Ring*, page 7.

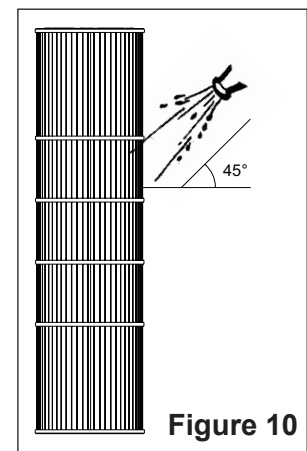
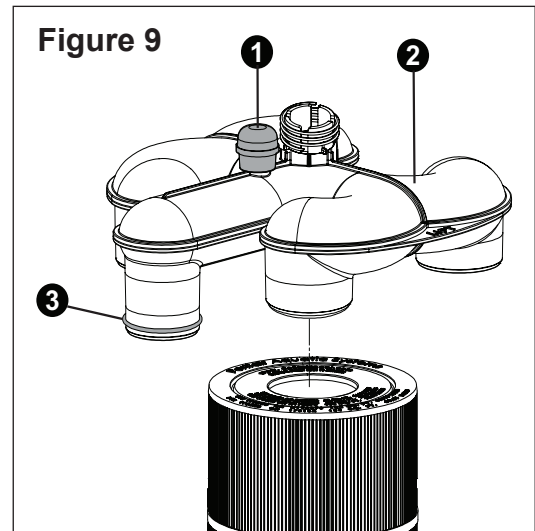

Figure 10

Acid Soaking the Filter Cartridges

After an extended period of operation, it may be necessary to soak the filter cartridges in an acid solution. Acid soaking will remove algae, calcium carbonate, iron and other mineral build-ups from the filter cartridges. If not removed, these mineral deposits can lead to the restriction of water flow through the FullFloXF® Q-Series Cartridge Style D.E. Filter and can impede efficient operation of the equipment.

⚠ WARNING

Muriatic acid is corrosive and can lead to inflammation or burns to body tissue.

ALWAYS wear rubber gloves, safety glasses and an N-95 dust mask when handling acid to prevent serious bodily injury.



⚠ CAUTION

To prevent degradation of the acid by UV light, store muriatic acid in an opaque container and away from direct sunlight.

REQUIRED TOOLS:

- Large Plastic Container
- Garden Hose with a Straight Flow Nozzle
- Muriatic Acid (stored in opaque container)
- Rubber Gloves
- Safety Glasses
- N-95 Dust Mask

PROCEDURE:

1. Remove all oils and cleaning solutions from the cartridges.

⚠ CAUTION

Acid soaking without performing this step will result in permanent restriction of water flow through the filter and premature cartridge failure.

2. Put on protective equipment - rubber gloves, safety glasses and N-95 dust mask.
3. In a large plastic container, create a solution of one part muriatic acid to twenty parts water. See **Figure 11**.

⚠ WARNING

Introduce the muriatic acid as close to the water's surface as possible. This will minimize splash and reduce the risk of user contact with the acid.

4. Gently place the bottom of the cartridges into the acid solution. Allow the cartridges to soak in the solution for 10 minutes, or until bubbling stops.
5. Turn the cartridges over, placing the top halves into the solution. Allow the top halves of the cartridges to soak for 10 minutes, or until bubbling stops.
6. Remove the cartridges from the acid solution.
7. Using a garden hose with a straight flow nozzle, thoroughly wash down the entire filter cartridge. Wash from the top down, holding the nozzle at a 45-degree angle to the cartridge. See **Figure 10**, on previous page.
8. Reinstall the cartridges and dispose of the acid solution in accordance with local regulations.

Figure 11

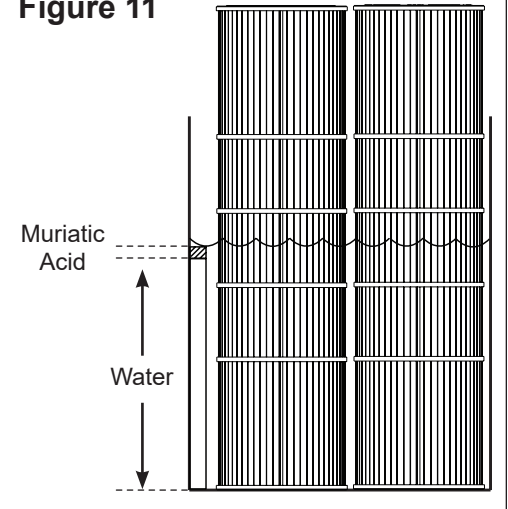

Replacing Filter Cartridges

Filter cartridge life will vary with pool conditions such as bather load, wind, dust, etc. You can expect an average cartridge life of three years under normal conditions.

To replace filter cartridges:

1. Follow *Opening the Filter*, page 5 exactly.
2. Separate the Top Manifold (1) from the filter cartridges and lay the manifold to the side. See **Figure 12**.
3. Carefully remove each cartridge separately.
4. Place the four replacement cartridges onto the support pipes in the bottom of the tank.
5. Reinstall the Top Manifold onto the cartridges and verify the O-ring (2) is secured to the manifold. See **Figure 12**.
6. Follow *Installing the Filter Lid and Clamp Ring*, page 7.
7. Recoat the cartridges with D.E. according to the *Coating the Filter Cartridges with D.E.*, page 6.

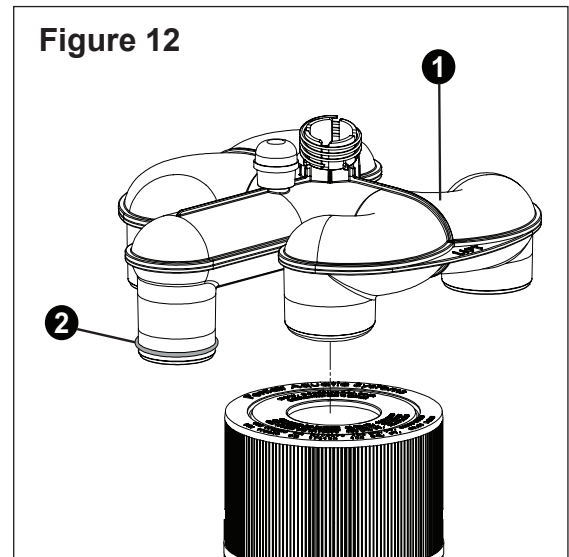

Cleaning the Manual Air Relief Valve

REQUIRED TOOLS:

- 5/16" Drill Bit (to check air passage)
- Silicone-based Lubricant (if needed)

PROCEDURE:

1. Shut off pump and relieve pressure.
 - a. Turn the pump OFF and shut OFF any automatic controls (e.g., timers) and disconnect power to ensure that the system is not inadvertently started during maintenance.
 - b. Open the manual air relief valve by turning the valve cover assembly a quarter turn counter-clockwise until it snaps into the full open position.
 - c. Stand clear of the filter and wait until all pressure is relieved.
Pressure gauge must read zero (0 psi).
2. With the relief valve attached to the FullFloXF® Q-Series Cartridge Style D.E. Filter tank, pull out the locking tabs and unlock the valve stem and cover assembly from the valve body with a counter-clockwise turn. See **Figure 13**.
3. Remove valve stem and cover assembly from the valve body. See **Figure 13**.
4. Clean and check the valve stem and body:
 - a. Clean off any debris.
 - b. Verify that the filter tank's air passage is open by inserting a 5/16" drill bit through the valve body.
 - c. Verify that the valve stem O-rings are in good condition, properly positioned, and lubricated with a silicone-base lubricant.

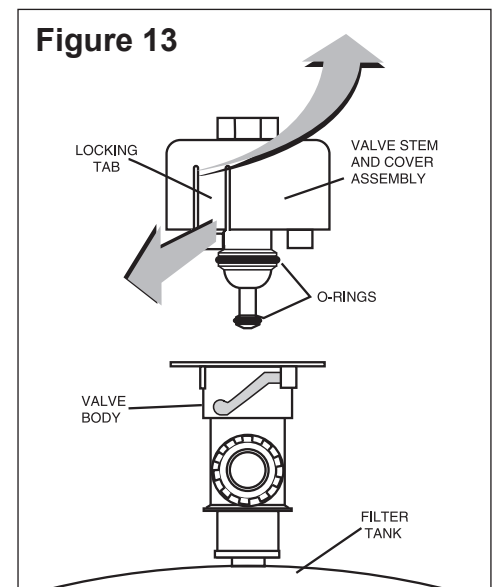

If needed, use only a PTFE or silicone-base lubricant on the O-rings. Use of petroleum based products on O-rings will damage the equipment.

5. Reinstall the valve stem and cover assembly with a downward and clockwise motion until it snaps into position.

TROUBLESHOOTING

⚠ WARNING



Air entering the system can cause the lid to separate from the filter. If the below symptoms are observed, do not attempt to remove or tighten the clamping system or perform any other servicing until you have shut off pump and relieved all air and pressure in accordance with *Opening the Filter*, page 5.

PROBLEM	POSSIBLE CAUSE	CORRECTIVE ACTION
Air Entering Filter System	Low water level in pool or spa.	Add water to the pool or spa.
	Pump skimmer basket is clogged.	Remove all debris from the skimmer basket.
	Suction cleaner hose is pulling in air.	Check the cleaner hose for damage. Replace hose as needed.
	Pump lid is not sealing.	Inspect the pump lid O-ring for damage. Replace the O-ring as needed.
	Pump suction line is pulling in air.	Inspect the suction line for damage. Repair as needed.
Short Filter Cycles	Poor backwash procedure.	Backwash the filter as instructed in <i>Backwashing the Filter</i> , page 9.
	Too little or too much D.E.	Backwash and add correct amount of D.E. given in <i>Preparing Diatomaceous Earth (D.E.)</i> , page 6.
	Algae in water.	Correct and maintain proper water chemistry. Frequent backwashing may be necessary until pool is free of algae.
	Plaster dust from pool is building up in filter.	New pools can frequently release high amounts of plaster dust into the filter. This usually lessens over time and no action is needed.
	Oils, minerals or debris building up on filter cartridges.	Clean the filter cartridges according to instructions given on pages 9-11.
Cloud of Dirt Entering Pool	A brief "cloud" of dirt may appear during system start-up.	This is a normal characteristic of D.E. filters, and does not require action.
Diatomaceous Earth (D.E.) Continuously Entering Pool NOTE: Ensure the foreign material in the pool is diatomaceous earth.	Internal parts not assembled correctly.	Check assembly of internal parts making sure they are correctly installed.
	Damaged manifold.	Replace manifold.
	Damaged filter cartridge.	Replace cartridge.
	Diatomaceous earth back up at main drain.	Check for air leaks and repair as needed. Air leaks can cause system to drain down allowing D.E. back to the pool.
	Missing air bleed screen cap.	Replace cap.
Leak in Filter Tank	Damaged O-ring.	Replace O-ring.
	Dirty O-ring.	Clean O-ring and all tank surfaces it comes in contact with.
	Clamp ring is loose.	Tighten clamp ring according to <i>Installing the Filter Lid and Clamp Ring</i> , page 7.
	Crack in lid or tank body.	Replace cracked component.
High Pressure Reading after Backwash or Manual Cleaning	Restriction on discharge side.	Locate and correct restriction of filter.
	Mineral deposits on filter cartridges.	Acid soak the filter cartridges. Refer to <i>Acid Soaking the Filter Cartridges</i> , page 11.
	Excessive water flow through filter (pump horsepower may exceed filter flow rate).	Determine pump flow rate and compare with maximum filter flow rate requirement.
	If heater is included in system, flow valve on heater may be stuck open.	Adjust or replace flow valve as needed.
	Pressure gauge not working properly.	Inspect and repair or replace gauge as needed.

TECHNICAL DATA

Dimensional Drawings

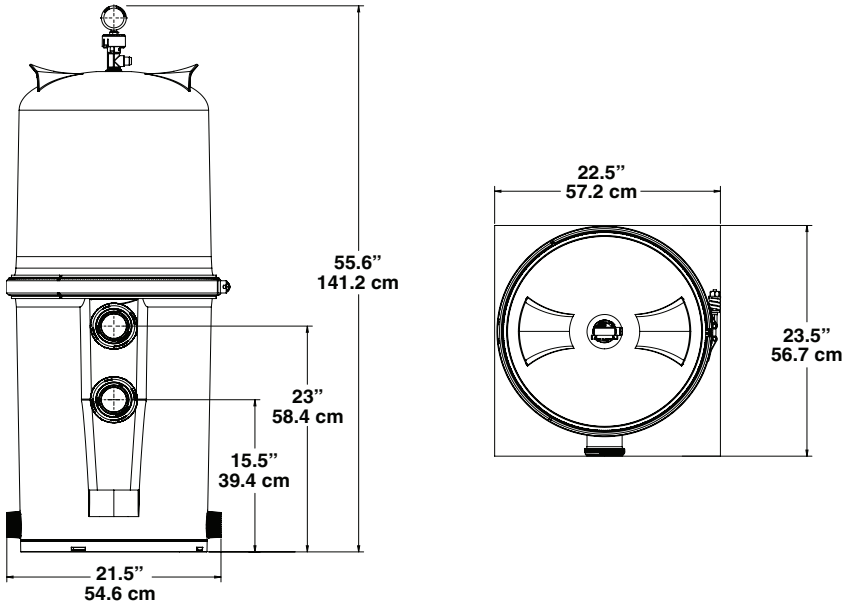

Head Loss Comparison Curves

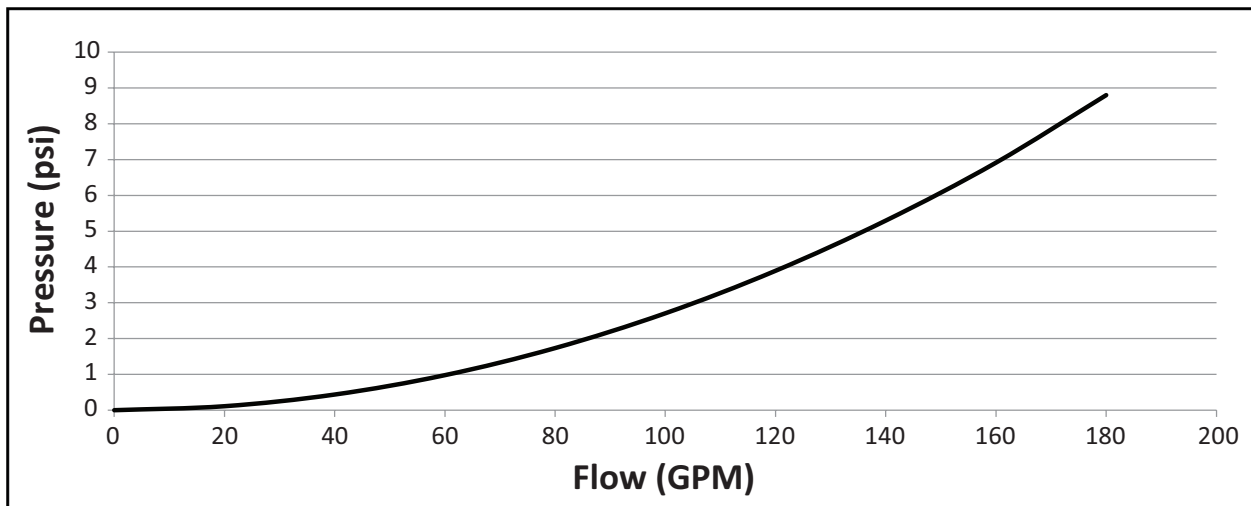

Recommended Flow Rates

Filter P/N	Filter Area Sq. Ft.	Vertical* Clearance	Flow Rate (GPM)	Res. Turnover Capacity (Gallons)		
				8 hours	10 hours	12 hours
188616	120	80"	180	86,400	108,000	129,600

Actual system flow will depend on plumbing size and other system components.

* Required clearance to remove filter cartridges.

REPLACEMENT PARTS

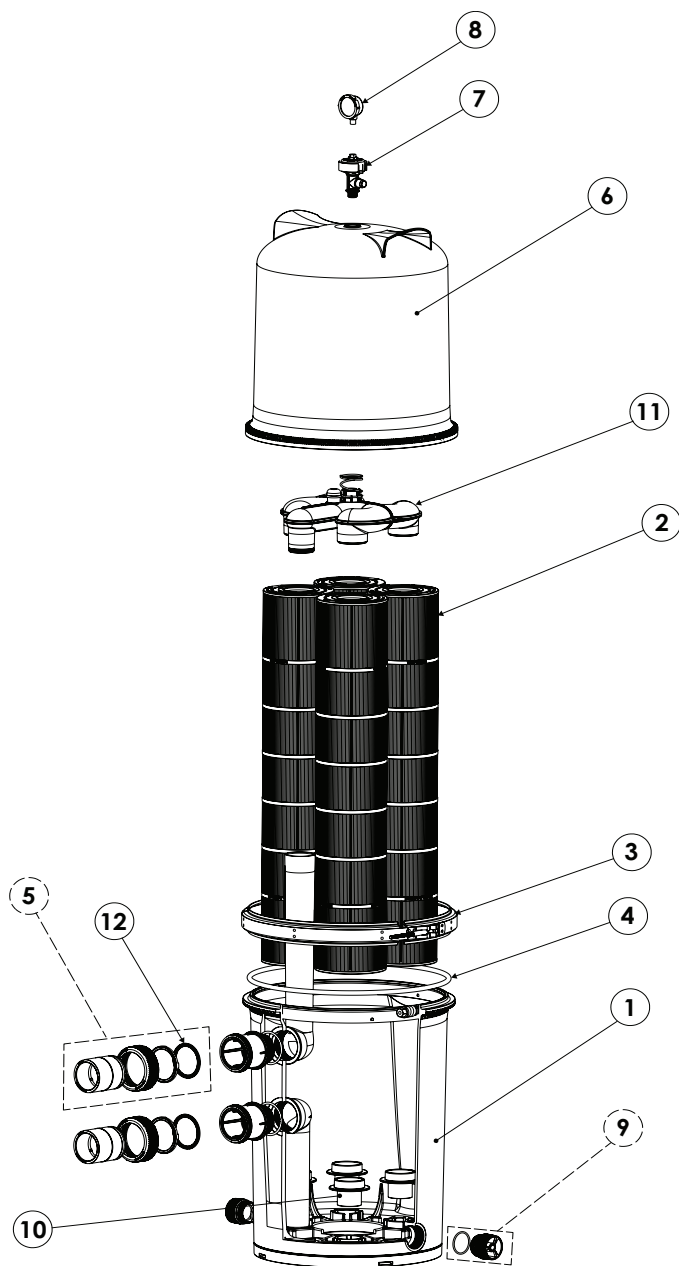

Item	Description	Part No.	Qty.
1*	Tank Bottom	175403	1
2	Filter Cartridge	178750z	4
3	Clamp Ring Assembly	190003	1
4	O-ring, Tank	39010200z	1
5	Bulkhead Kit	178829	2
6	Tank Lid	178833	1
7	Manual Air Relief Valve	98209800	1
8	Pressure Gauge	190058z	1
9	Drain Plug Kit	178816	1
10	Support Pipe	178697z	4
11	Top Manifold Kit	178838	1
12	Diamond Seal Kit	410016z	1
--	Anchor Clamp Kit	178840	1

(*) - Tank Bottom (item #1) includes items 5 and 9.



1620 HAWKINS AVE., SANFORD, NC 27330 • (919) 566-8000
10951 WEST LOS ANGELES AVE., MOORPARK, CA 93021 • (805) 553-5000

All indicated Pentair trademarks and logos are property of Pentair. Third party registered and unregistered trademarks and logos are the property of their respective owners.

© 2024 Pentair. All rights reserved. WWW.PENTAIR.COM



P/N 198285 REV. C 2/19/24