

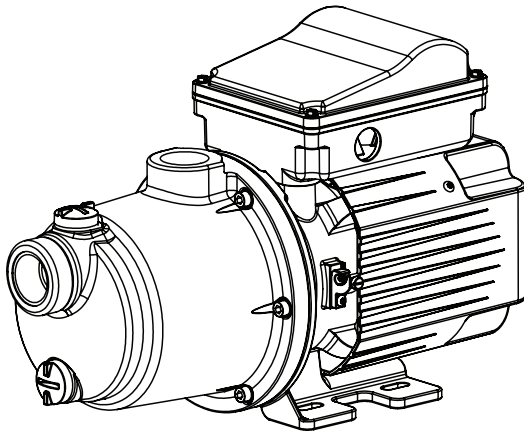

HYDROBOOST™

BOOSTER PUMP



INSTALLATION AND USER'S GUIDE

IMPORTANT SAFETY INSTRUCTIONS
READ AND FOLLOW ALL INSTRUCTIONS
SAVE THESE INSTRUCTIONS

CUSTOMER SERVICE / TECHNICAL SUPPORT

If you have questions about ordering Pentair replacement parts, and pool products, please contact:

Customer Service and Technical Support
(8 A.M. to 4:30 P.M. — Eastern/Pacific Times)
Phone: (800) 831-7133
Fax: (800) 284-4151

Web site

Visit www.pentair.com for information about other Pentair products.

Sanford, North Carolina (8 A.M. to 4:30 P.M. ET)
Phone: (919) 566-8000
Fax: (919) 566-8920

Moorpark, California (8 A.M. to 4:30 P.M. PT)
Phone: (805) 553-5000 (Ext. 5591)
Fax: (805) 553-5515

TABLE OF CONTENTS

Important Safety Instructions	ii	Operation	7
Introduction	1	Preparation for Operation	7
Pump Overview	1	Starting the Pump	7
Electrical Specifications	1	Automatic Timer	7
Pump Dimensions	1	Maintenance	8
Installation	2	Winterizing	8
Location	2	Motor Care	8
Piping	2	Start Up after Winterizing	8
Typical Installation	2	Troubleshooting	9
Installation with a Heater	3	Replacement Parts	10
Installation with a Solar Heater	3	Parts List	10
Installation with Pool and Spa		Performance Curves	11
Combination	3		
Installing the Pump Hoses	4		
Electrical Installation	5		
Connecting to a Power Source	5		
Wiring the Pump for 230 VAC	6		
Wiring the Pump for 115 VAC	6		

SAVE THESE INSTRUCTIONS



This is the safety alert symbol. When you see this symbol on your system or in this manual, look for one of the following signal words and be alert to the potential for personal injury.



DANGER Warns about hazards that can cause death, serious personal injury, or major property damage if ignored.



WARNING Warns about hazards that may cause death, serious personal injury, or major property damage if ignored.



CAUTION Warns about hazards that may or can cause minor personal injury or property damage if ignored.

NOTE indicates special instructions not related to hazards. Carefully read and follow all safety instructions in this manual and on equipment. Keep safety labels in good condition; replace if missing or damaged.

IMPORTANT NOTICE



This guide provides installation and operation instructions for this product. Consult Pentair with any questions regarding this equipment.

Attention Installer: This guide contains important information about the installation, operation and safe use of this product. This information should be given to the owner and/or operator of this equipment after installation or left on or near the pump.

Attention User: This manual contains important information that will help you in operating and maintaining this product. Please retain it for future reference.

IMPORTANT SAFETY INSTRUCTIONS

When installing and using this electrical equipment, basic safety precautions should always be followed, include the following:

⚠ WARNING Do not permit children to use this product.

⚠ WARNING **RISK OF ELECTRICAL SHOCK.** Connect only to a branch circuit protected by a ground-fault circuit-interrupter (GFCI). Contact a qualified electrician if you cannot verify that the circuit is protected by a GFCI.

⚠ WARNING This unit must be connected only to a supply circuit that is protected by a ground-fault circuit-interrupter (GFCI). Such a GFCI should be provided by the installer and should be tested on a routine basis. To test the GFCI, push the test button. The GFCI should interrupt power. Push the reset button. Power should be restored. If the GFCI fails to operate in this manner, the GFCI is defective. If the GFCI interrupts power to the pump without the test button being pushed, a ground current is flowing, indicating the possibility of an electric shock. Do not use this pump. Disconnect the pump and have the problem corrected by a qualified service representative before using.

⚠ CAUTION This pump is for use with permanent swimming pools and may also be used with hot tubs and spas if so marked. Do not use with storable pools. A permanently-installed pool is constructed in or on the ground or in a building such that it cannot be readily disassembled for storage. A storable pool is constructed so that it is capable of being readily disassembled for storage and reassembled to its original integrity.

General Warnings

- The booster pump is not submersible.
- Code requirements for the electrical connection differ from state to state. Install equipment in accordance with the current National Electrical Code and all applicable local codes and ordinances.
- Before servicing the pump; switch OFF power to the pump by disconnecting the main circuit to the pump.
- This appliance is not intended for use by persons (including children) of reduced physical, sensory or mental capabilities, or lack of experience and knowledge, unless they have been given supervision or instruction concerning the use of the appliance by a person responsible for their safety.

⚠ DANGER FAILURE TO FOLLOW ALL INSTRUCTIONS AND WARNINGS CAN RESULT IN SERIOUS BODILY INJURY OR DEATH. THIS PUMP SHOULD BE INSTALLED AND SERVICED ONLY BY A QUALIFIED POOL SERVICE PROFESSIONAL. INSTALLERS, POOL OPERATORS AND OWNERS MUST READ THESE WARNINGS AND ALL INSTRUCTIONS IN THE OWNER'S MANUAL BEFORE USING THIS PUMP. THESE WARNINGS AND THE OWNER'S MANUAL MUST BE LEFT WITH THE POOL OWNER.

⚠ DANGER SUCTION ENTRAPMENT HAZARD: STAY OFF THE MAIN DRAIN AND AWAY FROM ALL SUCTION OUTLETS!



THIS PUMP PRODUCES HIGH LEVELS OF SUCTION AND CREATES A STRONG VACUUM AT THE MAIN DRAIN AT THE BOTTOM OF THE BODY OF WATER. THIS SUCTION IS SO STRONG THAT IT CAN TRAP ADULTS OR CHILDREN UNDER WATER IF THEY COME IN CLOSE PROXIMITY TO A DRAIN OR A LOOSE OR BROKEN DRAIN COVER OR GRATE.

THE USE OF UNAPPROVED COVERS OR ALLOWING USE OF THE POOL OR SPA WHEN COVERS ARE MISSING, CRACKED OR BROKEN CAN RESULT IN BODY OR LIMB ENTRAPMENT, HAIR ENTANGLEMENT, BODY ENTRAPMENT, EVisCERATION AND/OR DEATH.

The suction at a drain or outlet can cause:

Limb Entrapment: When a limb is sucked or inserted into an opening resulting in a mechanical bind or swelling. This hazard is present when a drain cover is missing, broken, loose, cracked or not properly secured.

Hair Entanglement: When the hair tangles or knots in the drain cover, trapping the swimmer underwater. This hazard is present when the flow rating of the cover is too small for the pump or pumps.

Body Entrapment: When a portion of the body is held against the drain cover trapping the swimmer underwater. This hazard is present when the drain cover is missing, broken or the cover flow rating is not high enough for the pump or pumps.

Evisceration/Disembowelment: When a person sits on an open pool (particularly a child wading pool) or spa outlet and suction is applied directly to the intestines, causing severe intestinal damage. This hazard is present when the drain cover is missing, loose, cracked, or not properly secured.

Mechanical Entrapment: When jewelry, swimsuit, hair decorations, finger, toe or knuckle is caught in an opening of an outlet or drain cover. This hazard is present when the drain cover is missing, broken, loose, cracked, or not properly secured.

NOTE: ALL SUCTION PLUMBING MUST BE INSTALLED IN ACCORDANCE WITH THE LATEST NATIONAL AND LOCAL CODES, STANDARDS AND GUIDELINES.

⚠ DANGER **RISK OF ELECTRICAL SHOCK OR ELECTROCUTION: PUMPS REQUIRE HIGH VOLTAGE WHICH CAN SHOCK, BURN, OR CAUSE DEATH. BEFORE WORKING ON PUMP!** Always disconnect power to the pool pump at the circuit



breaker from the pump before servicing the pump. Failure to do so could result in death or serious injury to service person, pool users or others due to electric shock.

IMPORTANT SAFETY INSTRUCTIONS

The Virginia Graeme Baker (VGB) Pool and Spa Safety Act creates new requirements for owners and operators of commercial swimming pools and spas.

Commercial pools or spas constructed on or after December 19, 2008, shall utilize:

(A) A multiple main drain system without isolation capability with suction outlet covers that meet ASME/ANSI A112.19.8a Suction Fittings for Use in Swimming Pools, Wading Pools, Spas, and Hot Tubs and either:

(i) A safety vacuum release system (SVRS) meeting ASME/ANSI A112.19.17 Manufactured Safety Vacuum Release systems (SVRS) for Residential and Commercial Swimming Pool, Spa, Hot Tub, and Wading Pool Suction Systems and/or ASTM F2387 Standard Specification for Manufactured Safety Vacuum Release Systems (SVRS) for Swimming pools, Spas and Hot Tubs or (ii) A properly designed and tested suction-limiting vent system or (iii) An automatic pump shut-off system. Commercial pools and spas constructed prior to December 19, 2008, with a single submerged suction outlet shall use a suction outlet cover that meets ASME/ANSI A112.19.8a and either:

(A) A SVRS meeting ASME/ANSI A112.19.17 and/or ASTM F2387, or (B) A properly designed and tested suction-limiting vent system, or (C) An automatic pump shut-off system, or (D) Disabled submerged outlets, or (E) Suction outlets shall be reconfigured into return inlets.

WARNING TO MINIMIZE THE RISK OF INJURY DUE TO SUCTION ENTRAPMENT HAZARD:

- A properly installed and secured ANSI/ASME A112.19.8 approved anti-entrapment suction cover must be used for each drain.
- Each suction cover must be installed at least three (3') feet apart, as measured from the nearest point to nearest point.
- Regularly inspect all covers for cracks, damage and advanced weathering.
- If a cover becomes loose, cracked, damaged, broken or is missing, replace with an appropriate certified cover.
- Replace drain covers as necessary. Drain covers deteriorate over time due to exposure to sunlight and weather.
- Avoid getting hair, limbs or body in close proximity to any suction cover, pool drain or outlet.
- Disable suction outlets or reconfigure into return inlets.

WARNING A clearly labeled emergency shut-off switch for the pump must be in an easily accessible, obvious place. Make sure users know where it is and how to use it in case of emergency.

CAUTION For Installation of Electrical Controls at Equipment Pad (ON/OFF Switches, Timers and Automation Load Center)

Install all electrical controls at equipment pad, such as on/off switches, timers, and control systems, etc. to allow the operation (startup, shut-down, or servicing) of any pump or filter so the user does not place any portion of his/her body over or near the pump strainer lid, filter lid or valve closures. This installation should allow the user enough space to stand clear of the filter and pump during system start-up, shut down or servicing of the system filter.

⚠ DANGER



HAZARDOUS PRESSURE: STAND CLEAR OF PUMP AND FILTER DURING START UP. Circulation systems operate under high pressure. When any part of the circulating system (i.e. locking ring, pump, filter, valves, etc.) is serviced,

air can enter the system and become pressurized. Pressurized air can cause the pump housing cover filter lid and valves to violently separate which can result in severe personal injury or death. Filter tank lid and strainer cover must be properly secured to prevent violent separation. Stand clear of all circulation system equipment when turning on or starting up pump.

Before servicing equipment, make note of the filter pressure. Be sure that all controls are set to ensure the system cannot inadvertently start during service. Turn off all power to the pump. **IMPORTANT: Place filter manual air relief valve in the open position and wait for all pressure in the system to be relieved.**

Before starting the system, fully open the manual air relief valve and place all system valves in the "open" position to allow water to flow freely from the tank and back to the tank. Stand clear of all equipment and start the pump.

IMPORTANT: Do not close filter manual air relief valve until all pressure has been discharged from the valve and a steady stream of water appears. Observe filter pressure gauge and be sure it is not higher than the pre-service condition.

General Installation Information

- All work must be performed by a qualified service professional, and must conform to all national, state, and local codes.
- Install to provide drainage of compartment for electrical components.
- These instructions contain information for a variety of pump models and therefore some instructions may not apply to a specific model. All models are intended for use in swimming pool applications. The pump will function correctly only if it is properly sized to the specific application and properly installed.

WARNING Pumps improperly sized or installed or used in applications other than for which the pump was intended can result in severe personal injury or death. These risks may include but not be limited to electric shock, fire, flooding, suction entrapment or severe injury or property damage caused by a structural failure of the pump or other system component.

WARNING The pump can produce high levels of suction within the suction side of the plumbing system. These high levels of suction can pose a risk if a person comes within the close proximity of the suction openings. A person can be seriously injured by this high level of vacuum or may become trapped and drown. It is absolutely critical that the suction plumbing be installed in accordance with the latest national and local codes for swimming pools.

INTRODUCTION

Pump Overview

The HydroBoost™ Booster Pump provides high pressure water to your pressure side automatic pool cleaner. This booster pump is **NOT self-priming** and should not run unless the filter pump is running.

- THP: 0.8
WEF: 0.62
- Provides 50 psi at 13.2 GPM.
- Made from durable, corrosion-proof materials.
- Hose and adapters included.
- Ideal replacement for pressure-side booster pumps.

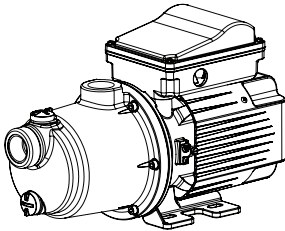

HydroBoost Booster Pump

Electrical Specifications

Motor: 115/230 VAC, 60 Hz, 1 Phase, Two-pole motor, 0.8 THP / 9.0-4.5 A.

Max Ambient Temperature.....	122°F / 50°C
Max Water Temperature.....	104°F / 40°C
Max Salt Content in Water.....	0.4%
pH-Range.....	4-9
Protection Type.....	IP44
Insulation Class.....	F
Revolutions per Minute (RPM).....	3450
Max Noise Level.....	75dB(A)
Motor Frame.....	IEC 71 TEFC
Phases.....	Single Phase
Inlet/Outlet Thread.....	1" NPT
Hydraulic Design.....	5 Stage

Pump Dimensions

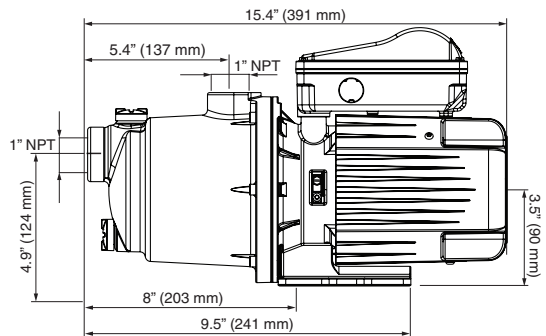
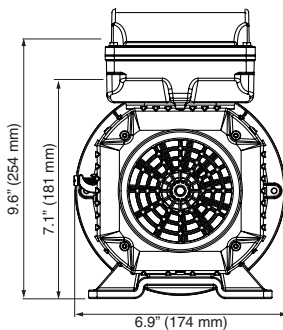

INSTALLATION

Only qualified service professionals should install the booster pump. Refer to "Important Safety Instructions" on pages ii-iv for safety information.

Location

1. Always connect the booster pump to a return line on the discharge side of filter.
2. Install the pump as close to the pool or spa as possible. To reduce friction loss and improve efficiency, use short, direct suction and discharge piping.
3. Install pump on a firm and level surface. It is recommended to bolt the pump to a concrete pad to prevent possible vibration noise during operation.
4. Install booster pump no closer than 5 ft. (1.5 m) from the inside wall of the pool and spa. Canadian installations require a minimum of 9.8 ft. (3 m).
5. Install the pump a minimum of 3 ft. (0.9 m) from a heater outlet.
6. Do not install the pump more than 8 ft. (2.4 m) above the water level or 3 ft. (0.9 m) below water level.
7. Install the pump in a well ventilated location protected from excessive moisture (i.e., rain gutters, sprinklers, splashing pool water, etc.).
8. For hot tubs and spas, do not install within the outer enclosure or beneath the skirt.
9. To allow ventilation and servicing of the pump, install with a rear clearance of at least 12 in. (0.3 m) from a wall or structure. Ensure there is enough space for the fan exhaust.

PVC Piping

1. Use at least 1-inch PVC pipe. If 1-inch diameter piping is used on the suction, and the length is more than 5 ft. (1.5 m), a larger pipe diameter is recommended.
2. To avoid strain on the pump, support both suction and discharge pipes independently. Place these supports near the pump.
3. Slope suction pipe slightly upward toward the pump to avoid air locking.

Note: To prevent flooding when removing pump for service, ensure all flooded suction systems have a valve (ball or gate) in the suction and discharge pipes.

Flexible Hose Piping

The booster pump comes with a flexible hose and adapters which can be used in place of PVC piping.

Ensure there are no sharp bends in your hose piping to prevent restricted flow. Vibration noise can occur if the booster pump is installed with flexible hoses.

Typical Installation

Connect the suction side of the booster pump after the filter to ensure a filtered water supply to the booster pump.

The booster pump must be connected to the return line on the discharge side of the filter.

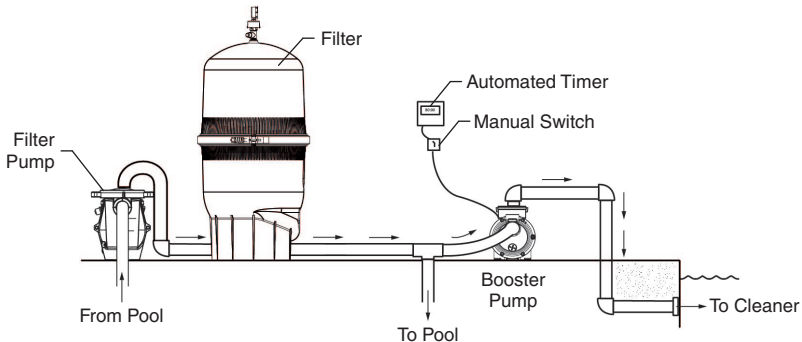

Typical Installation

Installation with a Heater

To install the booster pump in a system with a heater, install a tee after the filter. The tee directs a portion of the water to the booster pump and to the heater.

Do not connect the booster pump directly to the heater; the heated water can damage the booster pump if the heater malfunctions.

Install the booster pump at least 3 ft. (0.9 m) away from the heater to protect from excess ambient heat.

Installation with Solar Heaters

With or without a gas heater, install an in-line tee between the filter and solar heater.

This minimizes the possibility of an air lock in the booster pump each time the solar panel fills and assures ample water supply.

Installation with Pool and Spa Combination

If your pool is plumbed for a pool and spa combination, connect the suction side of the booster pump before the spa bypass valve. Ensure to install the booster pump at least 3 ft. (0.9 m) away from the heater to protect from excess ambient heat. See image below for plumbing configuration.

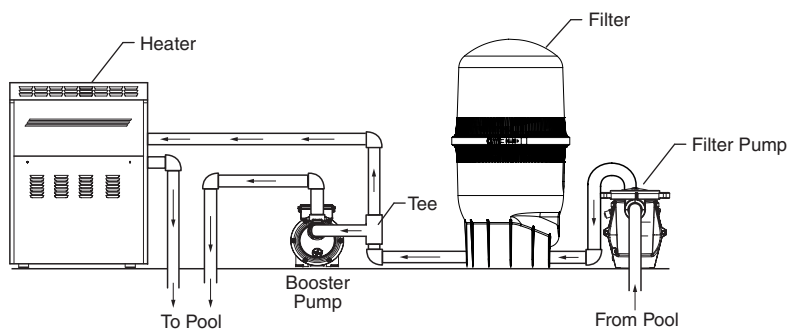
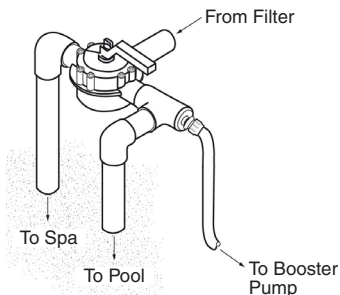

Installation with a Heater

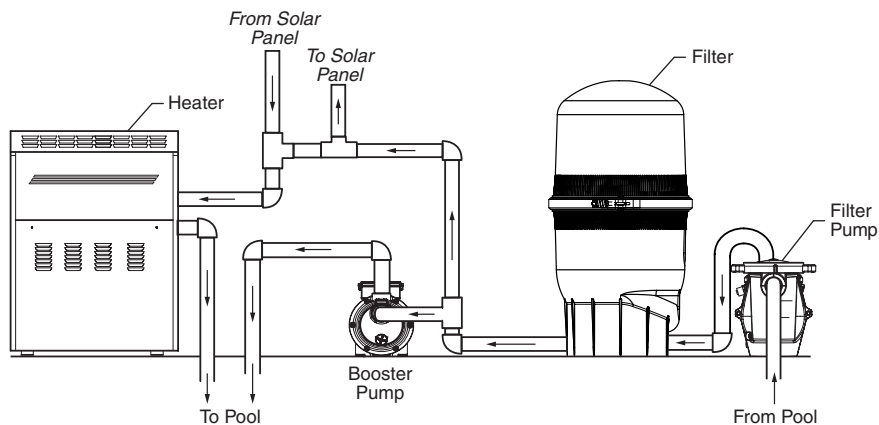

Installation with a Solar Heater

Installing the Pump Hoses

1. Wrap the threads of the white 1" to 3/4" reducer bushing with thread seal tape or pipe joint compound.
2. Screw the white reducer bushing into the pump outlet. Hand tighten + one (1) turn with a 12" adjustable wrench. *Torque = 60 in-lb (6.8 N-m).*
3. Unscrew the adapter cap from the adapter. Wrap the threads with thread seal tape or pipe joint compound.
4. Screw the black adapter into the white reducer bushing. Hand tighten the adapter + one (1) and a quarter turns with a 12" adjustable wrench.
Note: A second 12" adjustable wrench is recommended to hold the reducer bushing in place while tightening the adapter.
5. Cut the hose to the length needed to connect the booster pump to the return line. You may need to shape the hose end to round out the opening.
6. Slide the adapter cap up onto the hose. Ensure the adapter cap is up onto the hose before attaching hose to adapter.
7. Twist and push hose onto the adapter until the hose is flush with the adapter threads. Ensure the end of the hose is evenly bottomed out on the adapter.
Note: Apply heat or warm water to help attach hose if needed (heats makes hose more flexible).
8. Screw the adaptor cap onto the adaptor to secure the hose. Hand tighten the adapter cap. Turn one (1) time with a wrench if needed.
9. Repeat steps 1-8 for both outlet and inlet hose connection. Ensure there are no sharp bends or kinks when routing the hose.

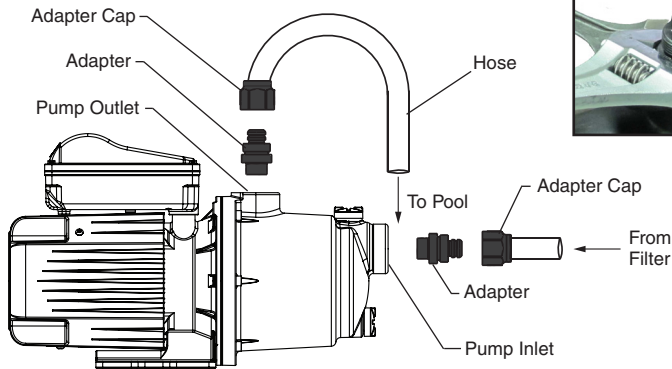

Complete Hose Assembly

ELECTRICAL INSTALLATION

⚠ WARNING



RISK OF ELECTRICAL SHOCK OR ELECTROCUTION.

This booster pump must be installed by a licensed or certified electrician or a qualified pool service professional in accordance with the current National Electrical Code and all applicable local codes and ordinances. Improper installation will create an electrical hazard which could result in death or serious injury to pool users, installers, or others due to electrical shock, and may also cause damage to property.

Always disconnect power to the booster pump at the circuit breaker before servicing the pump. Failure to do so could result in death or serious injury to service professionals, pool users or others due to electric shock.

Connecting to a Power Source

1. Turn off all electrical breakers and switches before wiring the motor.
2. Connect bonding wire to the bonding lug. Connect the ground wire to the green ground screw.
3. Ensure the wiring voltage is 230 VAC or 115 VAC \pm 10%. Permanent motor damage will occur if wiring voltage does not match.
4. Use #12 AWG for wiring up to 100 ft. (30.5 m) and #10 AWG for lengths longer than 100 ft. (30.5 m). If needed, use a heavier gauge (larger diameter) conductor. A heavier gauge will allow the motor to run cooler and more efficiently.
5. Ensure all electrical connections are clean and tight.
6. Cut the conductors to the appropriate length so they do not overlap or touch when connected to the terminal board.
7. Permanently ground the motor using the green ground terminal. Use #12 AWG for wiring up to 100 ft. (30.5 m) and #10 AWG for lengths longer than 100 ft. (30.5 m). Use the correct conductor size and type specified by the National Electrical Code. Ensure the ground conductor is connected to an electrical service ground.
8. Bond the motor to the pool structure in accordance with the National Electric Code. A solid copper bonding conductor not smaller than 8 AWG is required.
9. Connect the solid copper bonding conductor on the motor to all metal parts of the swimming pool, spa, or hot tub structure and to all electrical equipment, metal conduit, and metal piping within 5 ft. (1.5 m) of the inside walls of the swimming pool, spa, or hot tub. For Canada a 6 AWG or larger copper bonding conductor is required.

Wiring the Pump for 230 VAC

The booster pump is preset from the factory to operate on 230 VAC. Wires must be run through a water tight connector to prevent water from entering the wiring compartment.

Note: Never wire a 230 volt motor to a 115 volt line.

1. Ensure all electrical breakers and switches are off before wiring the motor and bonding wire is connected to the bonding lug.
2. Connect ground wire to ground (green) screw.
3. Ensure the voltage from the power source is 230 VAC \pm 10%
4. Connect Line 2 (L2) to the right most screw, labeled "N". Connect Line 1 (L1) to screw "L"
5. Ensure the gasket is in the top of the lid and place the lid back on the motor wiring the box.
6. Screw the four screws into the box in an cross pattern for an even seal. Hand tighten in two sequences. First, torque to 7 in-lbs (0.8 N-m), then torque to 15 in-lbs (1.7 N-m).

Note: Do not overtighten. This can strip the screw.

Wiring the Pump for 115 VAC

The booster pump is preset to operate on 230 VAC. The pump can also operate on 115 VAC by sliding the switch above the terminals to 115V. Wires must be run through a water tight connector to prevent water from entering the wiring compartment.

Note: Never wire a 115 volt motor to a 230 volt line.

1. Ensure all electrical breakers and switches are off before wiring the motor and bonding wire is connected to the bonding lug.
2. Connect ground wire to green ground screw.
3. Ensure the voltage from power source is 115 VAC \pm 10%
4. Connect Line 2 (L2) to the right most screw marked "N". Connect Line 1 (L1) to screw marked "L"
5. Ensure the gasket is in the top of the lid and place the lid back on the motor wiring the box.
6. Screw the four screws into the box in a cross pattern for an even seal. Hand tighten in two sequences. First, torque to 7 in-lbs (0.8 N-m), then torque to 15 in-lbs (1.7 N-m).

Note: Do not overtighten. This can strip the screw.

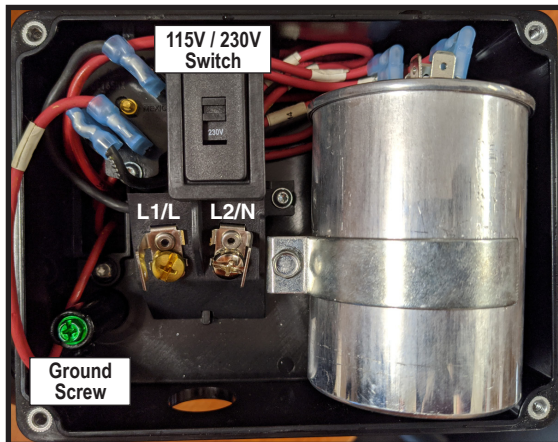

⚠ WARNING DO NOT run the pump dry. If the pump is run dry, the mechanical seal will be damaged and the pump will start leaking. If this occurs, the damaged seal must be replaced. ALWAYS maintain proper water level in your pool. Continued operation in this manner could cause a loss of pressure, resulting in damage to the pump case, impeller and seal.

⚠ WARNING Filter operates under high pressure. When any part of the circulating system (e.g., Lock Ring, Pump, Filter, Valves, etc.) is serviced, air can enter the system and become pressurized. Pressurized air can cause the filter lid to separate which can result in severe injury, death, or property damage resulting in damage to the pump case, impeller and seal, and may cause property damage and personal injury. To avoid this potential hazard, follow these instructions.



Preparation for Operation

Since the filter operates under high pressure, it is important to relieve any pressurized air before performing any maintenance or servicing.

Follow the instructions below to relieve pressure from the filtration system.

1. Stop pump, close valves on suction and discharge lines, and release all pressure from system before proceeding.
2. Open the manual air relief valve on top of the filter.
3. Open the suction side valve to release any trapped air. Turn the filter pump on and stand clear of the filter.
4. Bleed air from the filter until a steady stream of water comes out.
5. Close the manual air relief valve.

Starting the Pump

For startup, ensure the filter pump is running and an automatic pool cleaner is connected before starting the booster pump. The booster pump must have a water flow of at least 20 GPM from the filtration system to avoid running the pump dry.

1. Start the filter pump at least 30 minutes before starting the booster pump to ensure pump is primed.
2. Ensure all valves are open before starting the booster pump. Shutoff valves can be located between the filter pump and filter or between the filter pump and pool.
3. Open all filtration valves to allow enough water for the booster pump during operation.
4. If there is a SVRS (Safety Vacuum Release System) for the filter and booster pumps, set SVRS to shut off both pumps.
5. Ensure the filter is clean and free of debris. A clogged filter reduces the water supply to the booster pump and can cause damage to the pump mechanical seal.

Automatic Timer

A separate automatic timer is recommended for the booster pump to ensure proper water flow from the filter to the booster pump.

1. Set the timer to start the filter pump at least 30 minutes before and stop 30 minutes after the booster pump.
2. Ensure your pool cleaner is timed to run only for the length of time needed to clean the pool.

Note: Operating the booster pump while the filter pump is off can damage the pump.

3. Reset the timers if power is shut off or interrupted. Check your system timers to ensure the filter pump starts before the booster pump.
4. A separate manual switch is recommended in addition to an automatic timer to turn the booster pump off if the filter system needs to be shut off for any reason.

Example:

Set Timer:	Start	Stop
Filter Pump	8:00 AM	2:00 PM
Booster Pump	8:30 AM	1:30 PM

MAINTENANCE

Winterizing

Drain all water from the pump and piping when expecting freezing temperatures or when storing the pump for an extended period of time. In mild climate areas, when temporary freezing conditions may occur, run your filter system all night to prevent freezing.

Note: If the air temperature drops below 32°F (0°C), water in the pump can freeze and cause damage. Freeze damage is not covered under warranty.

Preventing Freeze Damage

- Shut off electrical power for the pump at the circuit breaker.
- Open the drain plug and allow water to drain out of the pump.
- Cap inlet piping after draining to keep water out of the pipes.
- Cover the motor to protect it from severe rain, snow, and ice.
- Avoid the use of plastic or other airtight materials when storing the pump. These materials can trap moisture and corrode the motor during storage.

Motor Care

Protecting motor from heat damage

- Ensure all enclosures are well ventilated to prevent overheating. Ensure the motor fan is working properly and the fan guard is not pushed against the fan.
- Install in a location that provides ample cross ventilation.
- Maximum ambient temperature for operation must not exceed 122°F / 50°C.

Protecting motor against dirt

- Protect from any foreign matter, i.e. dirt, plastic bags, pine straw, etc.)
- Avoid storing pool chemicals near the motor.
- Avoid sweeping or stirring up dust near the motor while in operation.
- Motors damaged by excessive water or dirt are not covered under warranty.

Protecting motor against moisture

- Avoid splashing water (pool, lawn sprinklers, etc.) near the pump.
- Protect from extreme weather conditions (snow, flooding, freezing temperatures) to avoid excess moisture and prevent freeze damage.
- Avoid operating pump if flooded.
- Completely attach the terminal cover to protect the wiring from moisture.
- This motor is an enclosed fan-cooled motor and can be damaged if water enters the motor. Motors damaged by water and/or moisture are not covered under warranty.

Start Up after Winterizing

1. Remove any temporary weather protection from around the system.
2. Disconnect all power sources and inspect all electrical wiring for damage or deterioration during shut down period.
3. Follow your filter installation and user's guide for filter system startup.
4. Open all valves in the suction and return lines in piping system.
5. Remove any winterizing plugs in piping system.
6. Close all drain valves and replace drain plugs in the piping system.
7. Check all piping connections for frost before reconnecting power sources and restarting the pump.

Note: Frost on the outside of the pipe may indicate a frozen line. Frozen pipes do not allow the system to prime properly and may result in running the pump dry and damaging the shaft seal.

If pump fails to start after shutdown period:

Disconnect all power before servicing. Insert a 1/4" hex key into the center hole of the fan guard and rotate motor shaft to free seal. Completely remove the hex key before reconnect power source.

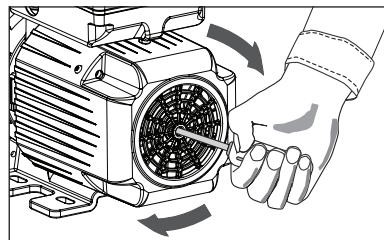

TROUBLESHOOTING

Use the following information to resolve possible issues with your booster pump.

PROBLEM	POSSIBLE CAUSE	CORRECTIVE ACTION
Pump motor does not run.	Power is off. Circuit is tripped. Fan guard pushed against fan. Pump is in OFF mode in a timer controlled circuit. Motor terminal wiring is incorrect. Impeller is blocked by debris.	Check power and reset. Check circuit breaker and reset. Move fan guard back into place with hammer and screwdriver. Check timer mode. Have terminal connections checked by an electrician. Clear debris from impeller.
Reduced pump flow and/or cleaner runs too slow.	Inlet and outlet line is blocked. Motor is wired improperly. Air pockets or leaks in suction line. Clogged impeller. Clogged filter.	Check for debris. Open line restriction. Check terminal connection. Check suction piping and valves. Ensure suction piping is at least 2" (51 mm) in diameter. Clear debris from impeller. Shut down pump and clean filter.
Motor Over-Heating.	Incorrect electrical supply connections. Wiring to pump is under-sized. Power company supply voltage is too low. Inadequate motor ventilation.	Check motor terminal. Tighten any loose connections. Increase wiring size. Check line voltage; if less than 90% or more than 110% of rated voltage, consult licensed electrician. Remove any restriction to air flow to reduce ambient temperature.
Mechanical Noise.	Pump vibrating or making loud noise on equipment pad. Cavitation. Fan guard pushed against fan.	Check pump location; bolt pump to concrete pad. Make sure suction and discharge pipes are adequately supported. Improve suction conditions. Increase pipe size. Increase discharge pressure. Remove bends or kinks in flexible hose piping. Move fan guard back into place with hammer and screwdriver.

REPLACEMENT PARTS

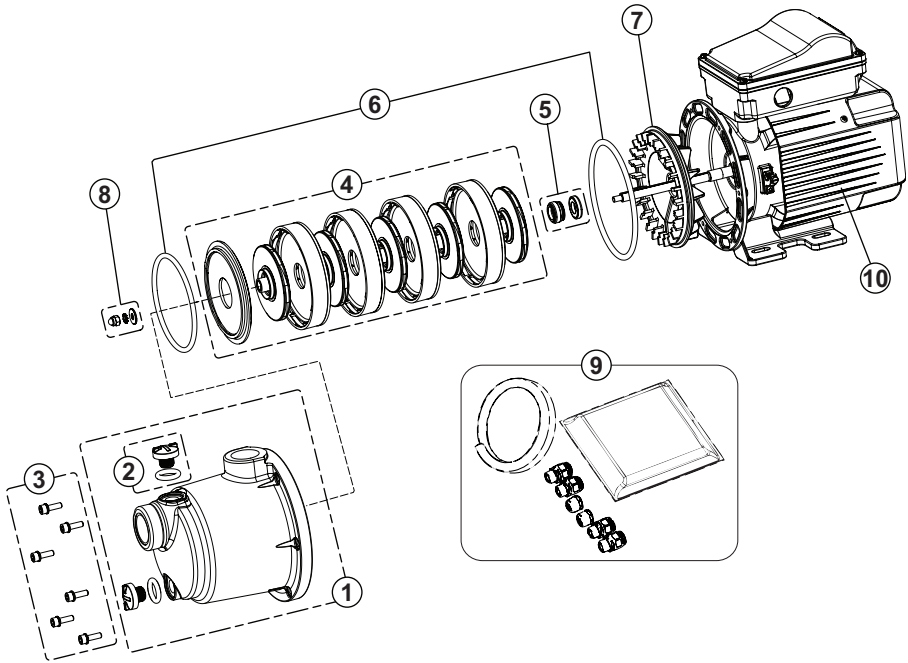

KIT	P/N	DESCRIPTION	KIT	P/N	DESCRIPTION
1	ZBR39320	PUMP BODY W/ DRAIN PLUGS	7	ZBR12210	SEAL PLATE KIT
2	ZBR12160	DRAIN PLUGS W/ O-RING KIT*	8	ZBR12270	END SHAFT FASTENERS KIT
3	ZBR12170	BODY PUMP FASTENERS KIT	9	353020	HOSE ADAPTER KIT**
4	ZBR39330	HYDRAULIC KIT	10	360519Z	MOTOR
5	ZBR43920	MECHANICAL SEAL KIT	-	357843	FAN SHROUD
6	ZBR12200	O-RING KIT			

*INCLUDES (2) DRAIN PLUGS AND (2) O-RINGS; HOUSING NOT INCLUDED.

**INCLUDES (2) REDUCER BUSHINGS, (4) ADAPTERS AND 6 FT. (1.8 M) HOSE.

Performance Curves

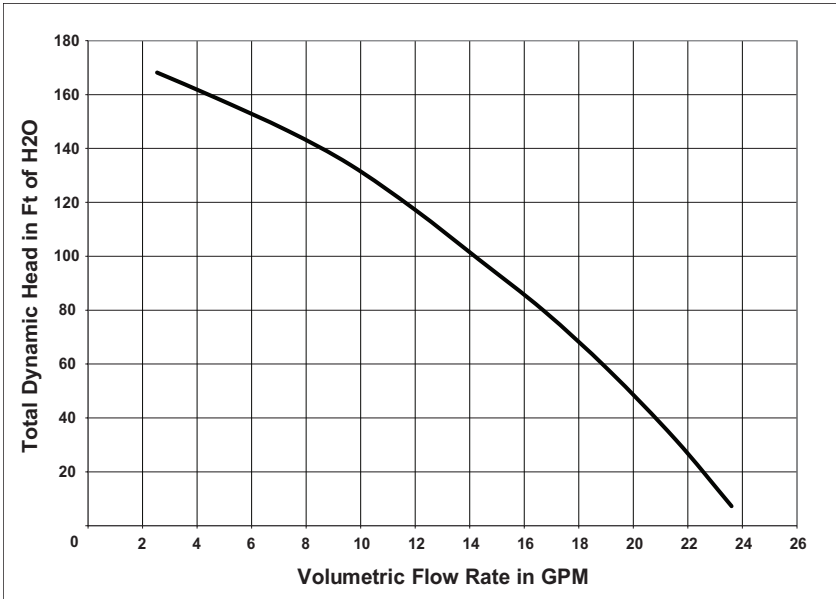



1620 HAWKINS AVE., SANFORD, NC 27330 • (919) 566-8000
10951 WEST LOS ANGELES AVE., MOORPARK, CA 93021 • (805) 553-5000

WWW.PENTAIR.COM

All indicated Pentair trademarks and logos are property of Pentair. Third party registered and unregistered trademarks and logos are the property of their respective owners. Because we are continuously improving our products and services, Pentair reserves the right to change specifications without prior notice.

© 2021 Pentair. All rights reserved. This document is subject to change without notice.



P/N 356360 REV. A 6/2/21