



General Safety Information

(General Safety Information Continued)

14. Check hose for weak or worn condition before each use. Make certain that all connections are tightly secured.
15. Periodically inspect the pump and the system components. Perform routine maintenance as required (see Maintenance section).
16. Use only pipe, hose and fittings rated for the maximum psi rating of the pump.
17. Do not use these pumps for pumping water or other liquids for human or animal consumption.

Troubleshooting

Symptom	Probable Cause(s)	Corrective Action(s)
Pump will not prime or retain prime after operating.	<ol style="list-style-type: none">1. Air leak in the suction line.2. Clogged foot valve or strainer.	<ol style="list-style-type: none">1. Repair or replace.2. Clean or replace
Flow rate is low.	<ol style="list-style-type: none">1. Incorrect speed.2. Piping is fouled or damaged.3. Clogged impeller or worn impeller.4. Discharge line restricted or undersized.5. High discharge pressure.	<ol style="list-style-type: none">1. Check drive.2. Clean or replace.3. Clean or replace.4. Flush out piping or replace.5. Check and reduce.
Pump runs but there is no fluid.	<ol style="list-style-type: none">1. Faulty suction piping.2. Pump is located too far from the fluid source.3. Gate valve is closed.4. Clogged strainer.5. Fouled foot valve.6. Discharge height is too great.7. Suction lift is too great.	<ol style="list-style-type: none">1. Replace.2. Relocate.3. Open.4. Clean or replace.5. Clean or replace.6. Lower the height.7. Lower the pump.
Liquid drips from the point where the shaft enters the pump casing, when the pump is full of liquid.	<ol style="list-style-type: none">1. Damaged mechanical seal.	<ol style="list-style-type: none">1. Replace. (See Mechanical Seal Replacement section.)
The pump starts and stops pumping.	<ol style="list-style-type: none">1. Fouled impeller.2. Faulty mechanical seal.3. Leak in the suction line.4. Leak in the foot valve.	<ol style="list-style-type: none">1. Clean.2. Replace.3. Repair.4. Repair or replace.
Excessive noise while pump in operation.	<ol style="list-style-type: none">1. Pump not secured to firm foundation.2. Piping not supported to relieve any strain on the pump assembly.3. Restricted suction line.4. Cavitation.	<ol style="list-style-type: none">1. Secure properly.2. Make necessary adjustments.3. Clean or correct.4. <ol style="list-style-type: none">a. Reduce speed.b. Increase inlet size.c. Use thinner material.

Drive Source Installation for the 9940-9750NRL Pedestal Mount Pump

This manual covers the installation of the basic drive configuration for the 9940-9750NRL centrifugal pump. Consult the manufacturer of your motor or engine for additional information.

Read all instructions and general safety information before attempting to install or operate the pump.

Belt/Pulley Drive Installation

Mounting Belts and Pulleys

Mount pulleys as close to the pump and motor engine shaft bearings as possible. Check the alignment with a straight edge as shown in Fig. 1. Make sure that the belt has proper tension. (Too much tension will cause bearing wear; too little will cause slippage.) See Fig. 2. Check with belt and pulley sources for specific recommendation.

To figure proper diameter of pump pulley, multiply motor/engine rpm by the diameter of the motor/engine pulley and divide that figure by the desired pump speed.

$$\text{Pump Pulley Size} = \frac{\text{Motor RPM} \times \text{Motor Pulley Size}}{\text{Desired Pump Speed}}$$

Refer to the pump performance charts to determine the desired speed to obtain the desired maximum flow.

Direct Drive — Flexible Coupling

For direct driving of Hypro centrifugal pumps with flexible couplings, make sure that the speed (rpm) of the gas engine or electric motor is within the maximum rated rpm of your pump. Make sure that shaft rotation is correct between the pump and the motor or gas engine (See Fig. 3).

1. Mount the motor or engine into position on the base.
2. Line-up the pump shaft with the straight edge as shown in Fig. 3 to assure they are aligned. Shim the pump if necessary to match the shaft height of the engine or motor. The shaft ends should not touch.
3. Mark the exact position of the pump on the base — remove and install the coupling halves on both shafts. Place the coupling center disc into one of the coupling halves.

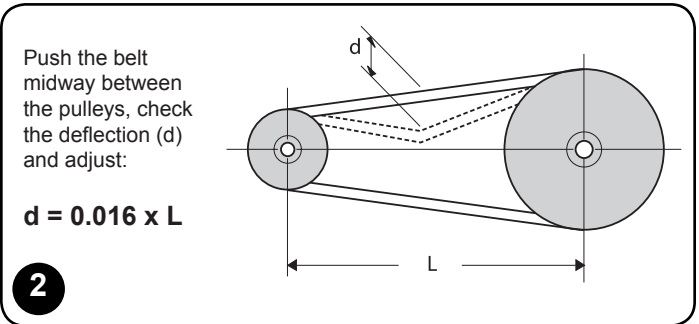
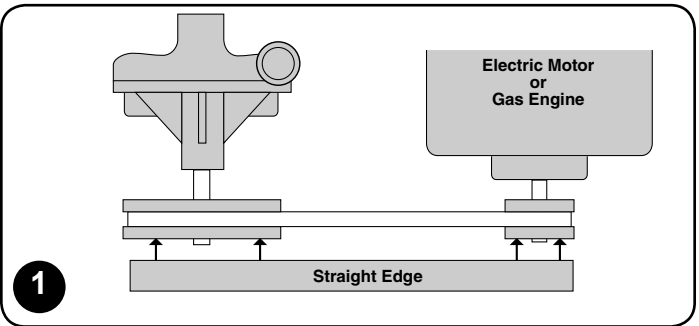

4. Re-position the pump, sliding the coupling halves together. NOTE: No end thrust should be applied to the pump when the coupling is connected.
5. Tighten the pump mounting and then the setscrews on each coupling.

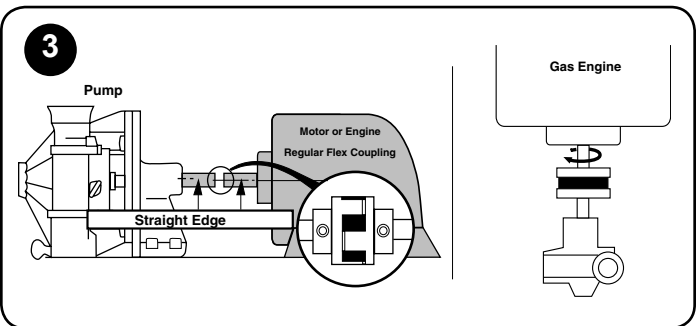

Electrical Hook-up

All electrical wiring should meet state and local ordinances. Improper wiring may not only be a safety hazard but may permanently damage the motor and/or pump!

1. Check that supply voltages match the motor's requirements.
2. Check the motor wiring and connect according to the motor instructions for matching supply voltage. Be sure of proper rotation! Improper rotation will severely damage the pump and void the warranty.
3. The power cord should be protected by conduit or by cable

and be of the proper gauge. It should be no longer than necessary.

4. The power should be drawn directly from a box with circuit breaker protection or with a fused disconnect switch.
5. Always switch off the power before repairing or servicing the pump and/or motor.
6. Check for the proper rotation of three phase motors.

Installation

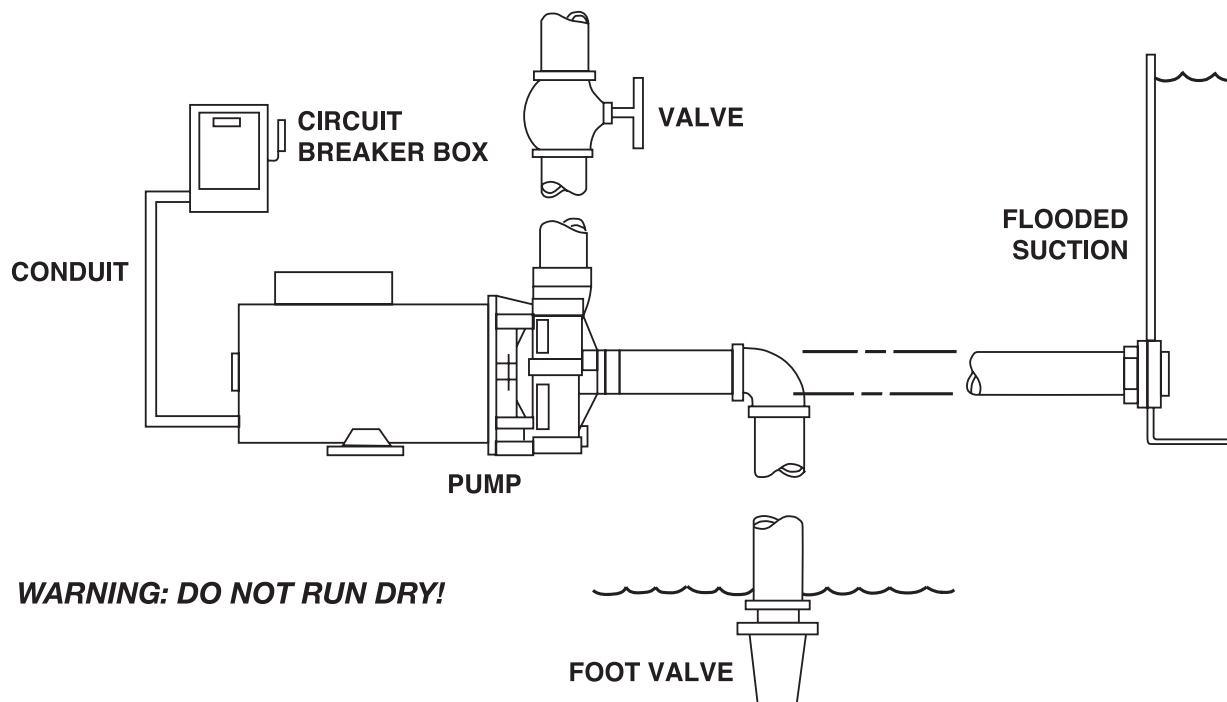

WARNING: DO NOT RUN DRY!

1. Position the pump as near as possible to the source being pumped. A flooded suction situation is preferred. The pump is *not* self-priming, therefore, if the fluid level is below the pump, a foot valve must be installed and the pump primed prior to start-up. (See the figure above.)
2. Mount the motor base to a secure, immobile foundation.
3. Use only plastic fittings on both the intake and discharge ports. Seal the pipe connections with teflon tape. These fittings should be self-supported and in neutral alignment with each port. (i.e. Fittings must not be forced into alignment which may cause premature line failure or damage to the pump volute.)
4. Never choke the intake. As much as possible, keep both input and discharge lines free of elbows and valves. Always use the pipe of adequate diameter. This will reduce friction losses and maximize output.
5. **The pump is non-self-priming! The pump must not be run dry!** Hypro recommends a flooded suction. If this is not possible, use a foot valve and prime the pump. (See the figure above.)

Performance for 9700 Series Pumps

9940-9750 Pedestal Mount Centrifugal Pump

Speed	10 PSI		15 PSI		20 PSI		25 PSI		30 PSI		35 PSI		Shut Off
	GPM	HP	GPM	HP	GPM	HP	GPM	HP	GPM	HP	GPM	HP	PSI
3000	102	1.5	88	1.4	72	1.4	38	1					27
3450	126	2.4	114	2.4	101	2.2	86	2.2	64	1.9	14	1.4	36
3600	132	2.7	119	2.6	107	2.5	97	2.5	80	2.3	52	2	39

9940-9751 and 9940-9753 Close-Coupled Noryl Centrifugal Pumps

Model	5 PSI		10 PSI		15 PSI		20 PSI		25 PSI		30 PSI		Shut Off
	GPM	AMPS	GPM	AMPS	GPM	AMPS	GPM	AMPS	GPM	AMPS	GPM	AMPS	PSI
9751	44	7.9	39	8	32	8.3	25	8.5	15	8.5	2	8.4	31
9753	88	14.1	82	14	74	14	66	14.4	55	14.4	37	13.6	35

Repair Instructions

Disassembly

1. Shut off the power to the motor before disconnecting any electrical wiring from the back of the motor.
2. Disassemble the body-motor assembly from the volute. (The volute may be left in-line if you wish.)
3. Remove the cap covering the shaft at the back motor and, with a large screwdriver, prevent the shaft from rotating while unscrewing the impeller.
4. Remove the ceramic piece from the impeller.
5. Detach the body from the motor.
6. Remove the carbon-graphite seal from the body by pressing the seal out from the back. Do not dig the seal out from the front.
4. Place the slinger (rubber washer) over the motor shaft and mount the body to the motor.
5. Carefully grease the boot or o-ring around the ceramic piece and press into the impeller. (On NRL model pumps, if the ceramic has an o-ring, the marked side goes into the impeller.)
6. Sparingly lubricate carbon-graphite and ceramic sealing surfaces with a lightweight machine oil. Do not use silicon lubricants or grease!
7. Thread the impeller onto the shaft and tighten! If required, remove the motor end-cap and use a screwdriver on the back of the motor shaft to prevent shaft rotation while tightening. Replace the motor end cap.

Pump End Assembly

1. Clean and inspect all pump parts (o-ring or gasket, seal seats, motor shaft, etc.)
2. Apply lubricant to the body bore hole and o-ring for seal installation.
3. Press the carbon graphite seal into the body while taking care not to damage the carbon graphite face.
8. Electrically, connect the motor so that the impeller will rotate counterclockwise when facing the pump with the motor end toward the rear. Incorrect rotation will damage the pump and void the warranty!
9. Seat the o-ring (Models 9940-9750NRL, 9940-9751NRL and 9940-9753NRL) in volute and assemble volute to the body.
10. Install the drain plug in the volute drain hole.

Seal Recommendation

Water Flushed Seals:

9940-9750NRL, 9940-9751NRL and 9940-9753NRL

Water flushed seals are recommended for abrasive solutions, high temperature service or against dead head conditions. Where conditions cause the pumped liquid to form crystals or if the pump remains idle for a period of time without adequate flushing, a water flush seal system is advised.

The water flush will provide decontamination of chemicals on elastomers and seal and seat faces while providing lubrication required for start up.

Two methods of water flush can be used:

1. Direct Plumbing to City Water

This provides the best possible approach to flushing the seal and seat faces. Use caution to conform to local city ordinances that may require back flow preventers. Back

flow preventers are a series of check valves required to prevent contamination of city water if there is a shut off of the water supply. Also, be aware of the addition of water into the chemicals pumped where some imbalance may be created altering the chemical's formulation and aggressiveness.

2. Recirculation of the Solution Pumped

This system takes a bleed off the pump discharge and recirculates the solution in the seal chamber. Although not nearly as effective as the direct water flush, this method will provide cooling to the seal and seat faces under operation. This system is not effective where crystallization occurs or for pumps in idle conditions. For internal recirculation to seal, drill the recess plug on the pump body (which is located at the 3 o'clock position) and leave the water flush port plugged.



Hazardous Substance Alert

1. Always drain and flush the pump before servicing or disassembling for any reason (see instructions).
2. Always drain and flush the pump prior to returning the unit for repair.
3. Never store pumps containing hazardous chemicals.
4. Before returning the pump for service/repair, drain out all

liquids and flush the unit with a neutralizing liquid. Then, drain the pump. Attach a tag or include a written notice certifying that this has been done. Please note that it is illegal to ship or transport any hazardous chemicals without United States Environmental Protection Agency Licensing.

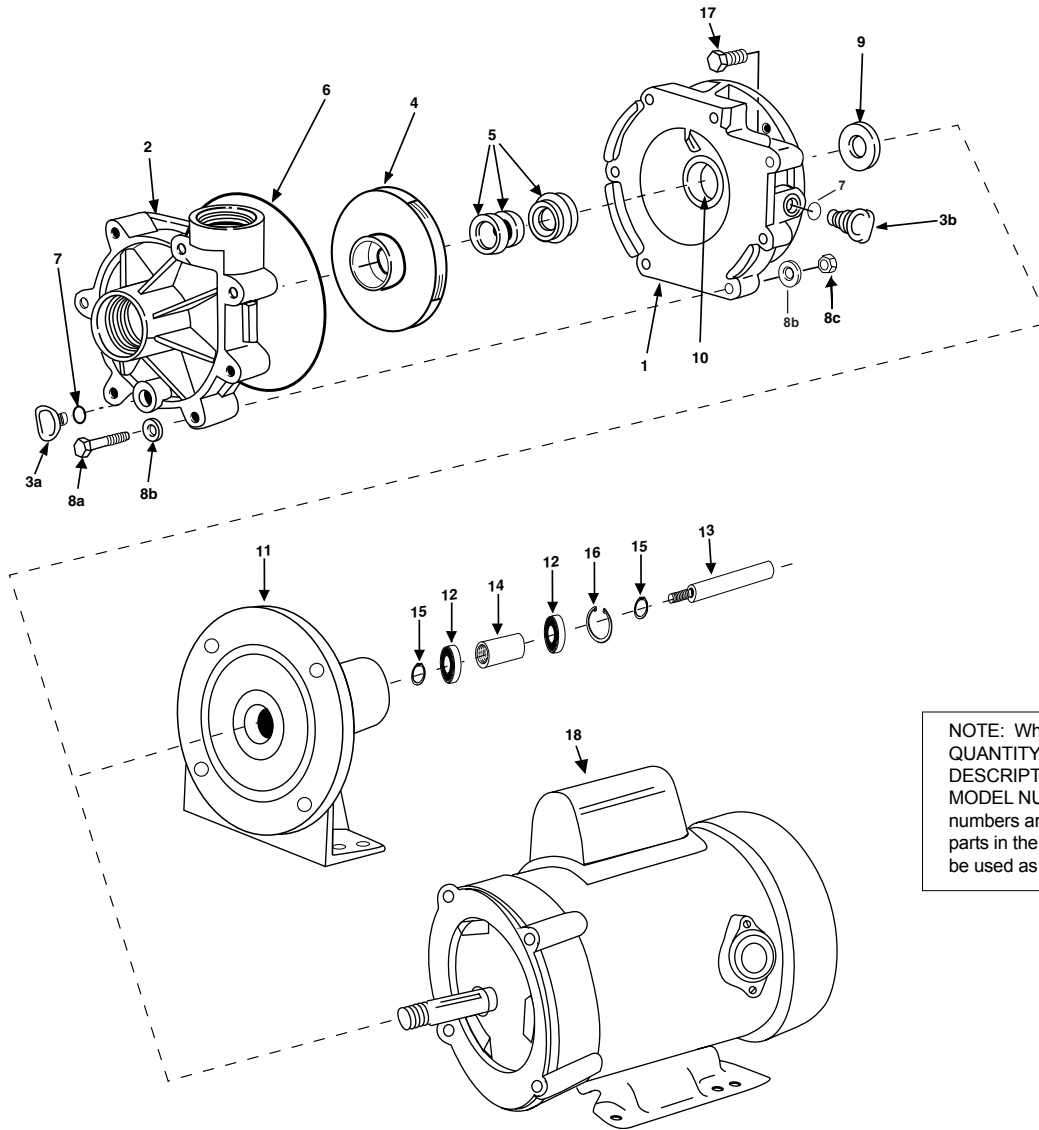

NOTE: When ordering parts, give QUANTITY, PART NUMBER, DESCRIPTION, and COMPLETE MODEL NUMBER. Reference numbers are used ONLY to identify parts in the drawing and are NOT to be used as order numbers.

**Model 9940-9750NRL
(Pedestal Mount)**

**Models 9940-9751NRL and 9940-9753NRL
(Pump and Motor Unit)**

Ref. No.	Qty. Req'd.	Part No.	Description
1	1	18775	Body
2	1	13257	Housing (Volute)
3a	1	13261	Drain Plug
3b	1	13261	Water Flush Plug
4	1	13343	Impeller
5	1	14528S	Seal/Seat Assembly
6	1	13259	O-ring (Volute)
7	2	13312	O-ring (Plug)
8a	7	18316	Machine Screw
8b	14	13314	Washer
8c	7	13311	Nut
9	1	14990	Slinger
10	1	18807	Seal O-ring
11	1	15057	Pedestal Mounting Bracket
12	2	04257	Ball Bearing
13	1	15839	Shaft
14	1	15838	Spacer
15	2	04259	Internal Rtg. Ring
16	1	12582	External Rtg. Ring
17	4	13309	Capscrew

Ref. No.	Qty. Req'd.	Part No.	Description
1	1	18775	Body
2	1	13257	Housing (Volute)
3a	1	13261	Drain Plug
3b	1	13261	Water Flush Plug
4	1	23438	Impeller (9940-9751NRL)
4	1	13255	Impeller (9940-9753NRL)
5	1	14528S	Seal/Seat Assembly
6	1	13259	O-ring (Volute)
7	2	13312	O-ring (Plug)
8a	7	18316	Machine Screw
8b	14	13314	Washer
8c	7	13311	Nut
9	1	14990	Slinger
10	1	18807	Seal O-ring
17	4	13309	Capscrew
18	1	13409H	Motor, 3/4 hp (9940-9751NRL)
18	1	13410H	Motor, 1-1/2 hp (9940-9753NRL)

• NOTES •

Limited Warranty on Hypro/SHURflo Agricultural Pumps & Accessories

Hypro/SHURflo (hereafter, "Hypro") agricultural products are warranted to be free of defects in material and workmanship under normal use for the time periods listed below, with proof of purchase.

- Pumps: one (1) year from the date of manufacture, or one (1) year of use. This limited warranty will not exceed two (2) years, in any event.
- Accessories: ninety (90) days of use.

This limited warranty will not apply to products that were improperly installed, misapplied, damaged, altered, or incompatible with fluids or components not manufactured by Hypro. All warranty considerations are governed by Hypro's written return policy.

Hypro's obligation under this limited warranty policy is limited to the repair or replacement of the product. All returns will be tested per Hypro's factory criteria. Products found not defective (under the terms of this limited warranty) are subject to charges paid by the returnee for the testing and packaging of "tested good" non-warranty returns.

No credit or labor allowances will be given for products returned as defective. Warranty replacement will be shipped on a freight allowed basis. Hypro reserves the right to choose the method of transportation.

This limited warranty is in lieu of all other warranties, expressed or implied, and no other person is authorized to give any other warranty or assume obligation or liability on Hypro's behalf. Hypro shall not be liable for any labor, damage or other expense, nor shall Hypro be liable for any indirect, incidental or consequential damages of any kind incurred by the reason of the use or sale of any defective product. This limited warranty covers agricultural products distributed within the United States of America. Other world market areas should consult with the actual distributor for any deviation from this document.

Return Procedures

All products must be flushed of any chemical (ref. OSHA section 1910.1200 (d) (e) (f) (g) (h)) and hazardous chemicals must be labeled/tagged before being shipped* to Hypro for service or warranty consideration. Hypro reserves the right to request a Material Safety Data Sheet from the returnee for any pump/product it deems necessary. Hypro reserves the right to "disposition as scrap" products returned which contain unknown fluids. Hypro reserves the right to charge the returnee for any and all costs incurred for chemical testing, and proper disposal of components containing unknown fluids. Hypro requests this in order to protect the environment and personnel from the hazards of handling unknown fluids.

Be prepared to give Hypro full details of the problem, including the model number, date of purchase, and from whom you purchased your product. Hypro may request additional information, and may require a sketch to illustrate the problem.

Contact Hypro Service Department at 800-468-3428 to receive a Return Merchandise Authorization number (RMA#). Returns are to be shipped with the RMA number clearly marked on the outside of the package. Hypro shall not be liable for freight damage incurred during shipping. Please package all returns carefully. All products returned for warranty work should be sent shipping charges prepaid to:

HYPRO / PENTAIR
Attention: Service Department
375 Fifth Avenue NW
New Brighton, MN 55112

For technical or application assistance, call the Hypro Technical/Application number: 800-445-8360, or send an email to: technical@hypropumps.com. To obtain service or warranty assistance, call the Hypro Service and Warranty number: 800-468-3428; or send a fax to the Hypro Service and Warranty FAX: 651-766-6618.

*Carriers, including U.S.P.S., airlines, UPS, ground freight, etc., require specific identification of any hazardous material being shipped. Failure to do so may result in a substantial fine and/or prison term. Check with your shipping company for specific instructions.

