



Cleanload™ Chemical Educator

Form L-1543
Rev. D

Original Instruction Manual



Models 3376-0870 and 3376-0871

Models 3376-1170 and 3376-1171

Models 3376-1670 and 3376-1671

Pentair

375 5th Ave., New Brighton, MN 55112

Phone: (651)766-6300 -OR- 800-424-9776 Fax: 800-323-6496

www.hypropumps.com

Contents

Introduction.....	3
Description.....	3
Purpose of Manual.....	3
Intended Use(s).....	3
Misuses.....	3
Cleanload™ Details.....	4
Description of Workstation.....	4
Tools.....	5
Lifting, Transport, and Intermediate Storage.....	5
Assembly and Installation.....	5
Assembly.....	5
Installation.....	5-6
Commissioning Start-Up, Operation, Shutdown.....	6
Information.....	6
Start-Up, Operation, Shutdown.....	7-8
Maintenance and Servicing.....	8
Information.....	8
Cleaning.....	8
Maintenance.....	8
Parts Illustration.....	9
Troubleshooting.....	10
Limited Warranty on Hypro/SHURflo Agricultural Pumps and Accessories.....	back page

Introduction

Description

Hypro Cleanload chemical eductors are designed to mix fluids and dry chemicals in a self-contained system. The inline eduction system allows the operator to mix chemicals quickly and safely. The Cleanload operates by receiving a fluid into the venturi eductor where a fluid or dry chemical is mixed in. The mixture is then transferred into a holding tank to be used for spraying crops. Construction features a polypropylene venturi eductor and hopper lid, polyethylene hopper tank and gaskets (FKM and EPDM).

Purpose of Manual

Hypro has provided this manual to provide instructions and requirements that must be met when installing, using and maintaining the product(s) identified on the cover.

If the product is sold, the seller must pass this manual on to the new owner.

The following special attention notices are used to notify and advise the user of this product of procedures that may be dangerous to the user or result in damage to the product.

NOTE

Notes are used to notify of installation, operation, or maintenance information that is important but not safety related.

⚠ CAUTION

Caution is used to indicate the presence of a hazard, which will or may cause minor injury or property damage if the notice is ignored.

⚠ WARNING

Warning denotes that a potential hazard exists and indicates procedures that must be followed exactly to either eliminate or reduce the hazard, and to avoid serious personal injury, or prevent future safety problems with the product.

⚠ DANGER

Danger is used to indicate the presence of a hazard that will result in severe personal injury, death, or property damage if the notice is ignored.

⚠ California Proposition 65 Warning -- This product and related accessories contain chemicals known to the State of California to cause cancer, birth defects or other reproductive harm.

Intended Use(s)

The Cleanload is designed and constructed for incorporation into a large variety of applications that require the mixing of liquid and dry chemicals. All other uses are to be considered misuses unless approved by the manufacturer.

The Cleanload can be used in a wide variety of conditions:

- Fluid temperatures ranging from 1 to 49°C (34 to 120°F)
- All weather conditions
- The Cleanload must only be used in outdoor or well-ventilated areas.

Misuses

DO NOT use the Cleanload in a potentially explosive environment.

DO NOT use the Cleanload without the hopper cover securely attached.

DO NOT operate the Cleanload with missing, damaged, or leaking parts. Inspect for damaged parts prior to each use.

DO NOT use the Cleanload in drinking water or any other system producing products for human consumption.

DO NOT use the Cleanload without the proper person protection equipment.

DO NOT use the Cleanload if it is not properly secured into position.

DO NOT exceed the maximum pressure when using the Cleanload.

Cleanload™ Details

General Cleanload Details		
Working Pressure	20-100 PSI	0.7-6.9 bar (See flow data for specific pressure data.)
Flow Rates	19-117 GPM	72-433 L/min
Operating Temperature	34-115°F	1-46°C
Weight	18 lbs.	8.2 Kg

Cleanload Model Details		
Model	Eductor Size	Flow Direction
3376-0870 3376-0871	8mm	Right Left
3376-1170 3376-1171	11mm	Right Left
3376-1670 3376-1671	16mm	Right Left

System Flow Rates:

3376-0870 & 3376-0871		
Input Pressure (PSI)	Eduction Rate (gal/sec)	Flow Rate (gal/min)
40	0.63	19.34
60	0.75	23.43
80	0.96	26.65
100	1.39	29.46

3376-1170 & 3376-1171		
Input Pressure (PSI)	Eduction Rate (gal/sec)	Flow Rate (gal/min)
20	0.57	27.06
40	0.86	38.09
60	0.85	44.58
80	1.21	50.46
100	1.18	55.38

3376-1670 & 3376-1671		
Input Pressure (PSI)	Eduction Rate (gal/sec)	Flow Rate (gal/min)
20	0.75	64.29
40	0.92	80.88
60	0.79	94.63
80	0.88	106.19
100	0.88	116.92

3376-0870 & 3376-0871		
Input Pressure (bar)	Eduction Rate (L/sec)	Flow Rate (L/min)
2.7	2.38	73.21
4.1	2.84	88.70
5.5	3.63	100.89
6.9	5.26	111.51

3376-1170 & 3376-1171		
Input Pressure (bar)	Eduction Rate (L/sec)	Flow Rate (L/min)
1.4	2.16	102.43
2.7	3.24	144.19
4.1	3.22	168.77
5.5	4.60	191.00
6.9	4.46	209.62

3376-1670 & 3376-1671		
Input Pressure (bar)	Eduction Rate (L/sec)	Flow Rate (L/min)
1.4	2.86	243.36
2.7	3.49	306.15
4.1	2.98	358.21
5.5	3.35	401.99
6.9	3.35	442.58

Description of Workstation

The Cleanload is designed to be used by the operator, when installed in an approved location, during the loading and draining of chemicals from the hopper, while the tank of the sprayer is being filled.

Tools

The Cleanload can be easily mounted with minimal tools and hardware provided by the installer. Mount the Cleanload using 3/8" or 10mm bolts.

The Cleanload is designed using Imperial (inch) size bolts, but it can be mounted by metric (mm) tools as well. In all cases, an adjustable spanner wrench can be used to fit any size bolt.

Lifting, Transport and Intermediate Storage

The packaging consists of a cardboard box and fillers for easy shipping and handling.

During unpacking, inspect the contents of the packaging to ensure that all components are accounted for and undamaged. If there are damaged or missing components, please contact the dealer or Hypro. Dispose of the packaging materials properly according to local laws.

Shipment of the Cleanload may be done by a variety of transportation methods, including road, sea, air, or rail. Ensure that the containers are securely fixed to the transport vehicle for safe shipment.

⚠ WARNING DO NOT stack more than three Cleanload packages high on a pallet and do not stack any additional items on top of Cleanload packages.

If the Cleanload is to be stored for an extended period of time before installation, store the Cleanload in its packaging in a cool dry area.

Assembly and Installation

Assembly

The Cleanload does not require assembly.

Installation

⚠ CAUTION Cleanload must be installed in accordance with Hypro installation instructions. Failure to follow instructions completely will void the Limited Warranty.

The Cleanload is a versatile tool that can be used in a variety of applications. Because of the wide range of equipment Cleanloads may be used with, it is not possible to list every installation detail. Consult the manufacturer's documentation for the equipment on which you are mounting the Cleanload to identify suitable plumbing connections and mounting locations.

- Securely mount the Cleanload in a place that is out of the way of moving equipment, protected from crops and terrain, and allows for safe routing of plumbing. Bolt in place using 3/8" or 10mm hardware. For mobile installations, the Cleanload should be attached to substantial framework capable of supporting it over rough terrain. The Cleanload should be mounted in a vertical position, ensuring that there is enough room for the hopper lid to be fully opened. Ensure that the ball valve handles are easily accessible and have enough clearance to complete their full range of motion.
- Connect inlet and outlet hoses, minimum 2" (51mm) internal diameter, using appropriate fittings. Hoses should be made of a compatible material(s) to work with the chemicals being used and a 200 psi (13.8 bar) pressure rating. Route hoses so that there is no risk of persons tripping, falling or running into them. Hoses should also be routed so that they are protected from abrasion and impact forces.
- The arrow on the eductor fitting indicates the direction of flow. Both the inlet and outlet of the eductor are compatible with 220 universal flanges.
- For on-board sprayer installations, the hose from the outlet should be routed to the top of the spray tank to prevent back-flow. Include anti-siphoning provisions, such as a one-way check valve, if a stand pipe is used inside the tank to discharge chemical below the fluid level, or if top-routing is not possible.

Installation - cont'd.

- Elbow fittings, reducers, check valves, and sharp turns in the plumbing create back-pressure on the eductor and reduce performance. Their use should be minimized. Instead of sharp turns or elbow fittings, make sweeping bends with reinforced hose. If sharp turns cannot be avoided, the plumbing should be oversized to reduce flow restriction. Do not reduce the size of the outlet hose or fittings.
- To gain the full benefit of the rinse systems built into the Cleanload, provision should be made so that the final rinse is made using clean water.
 - For on-board sprayer installations, a clean water rinse tank should be connected to the pump inlet with a 3-way valve to allow for a final clean water flush.
 - For transfer and tender truck installations, the final rinse can simply be made when clean water is being transferred into the spray tank.

Typical On-Board Sprayer Installation

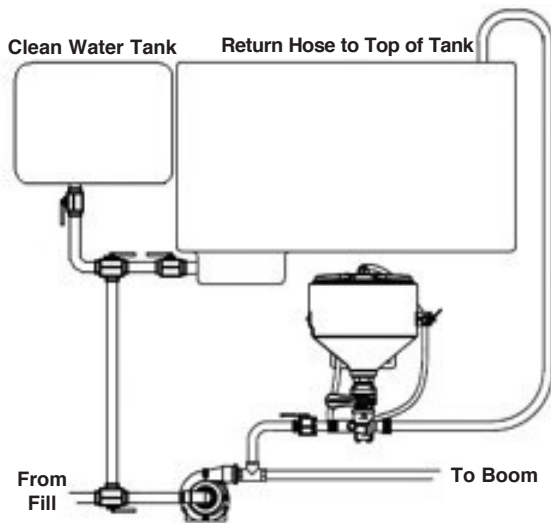

Typical Transfer / Tender Installation

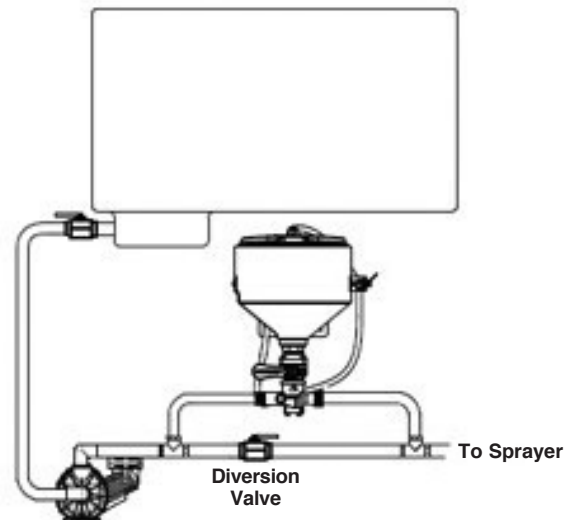

Commissioning Start-Up, Operation, Shutdown

Information

CAUTION Read the operating instructions completely before using the Cleanload.

- Always read and follow the chemical label instructions exactly. Understand safe practices for chemical handling, mixing, loading, cleaning and first aid.
- Always wear proper Personal Protective Equipment when handling chemicals, including gloves, eye protection, respirator and safety shoes.
- Always pay attention to wind conditions when dumping chemicals into the Cleanload hopper tank. Always stand up wind when dumping in windy conditions. Also make sure that there are no other persons downwind prior to dumping.
- Always check to make sure that there are no loose objects surrounding the Cleanload that could cause damage to the hopper tank or hoses.
- When operating the Cleanload at night, ensure lighting of 200 to 300 Lux is present.

NOTE IMMEDIATELY close the hopper lid and SHUT DOWN the system if leaks, errant spray, operation error, or malfunction occur.

Start-Up, Operation, Shutdown

Before Operation

1. Ensure all Cleanload valves are closed prior to starting, and inspect for leaks.
2. Unlock the lid by turning it counterclockwise, and open it. Inspect the hopper for cleanliness, remove foreign objects, and ensure the optional hopper outlet screen is properly seated.
3. Close the lid and lock it by turning it clockwise. Gently lift on the lid to ensure it is locked closed. If the lid will not close, will not lock, or is damaged, STOP and repair it before further use.

Start-Up

4. Divert pump flow to the Cleanload inlet line.
5. Open the INLET VALVE (Ref. 5 on pg. 8) on the eductor fitting.
6. Open the HOPPER OUTLET VALVE (Ref. 4 on pg. 8).
7. Unlock the lid by turning it counterclockwise. Open the lid slowly, taking care to check that no errant spray is detected before fully opening the lid.

Pouring Chemical into the Hopper

8. Open the SIDEWALL RINSE VALVE.
9. Measure the required amount of chemical using an accurate measuring vessel, scale, or flow meter. The hopper should not be used as a measurement vessel.
10. Carefully pour the chemical into the hopper taking care to not splash or spill.
11. The Cleanload is equipped with a ProClean Container Rinse System. It can be used to rinse empty liquid containers using steps 11 through 13.
12. Place the container to be rinsed upside down over the nozzle in the bottom of the hopper. Holding the container securely with two hands, press down to activate the CONTAINER RINSE VALVE for 30 seconds or longer until container is visibly clean.
13. When the container is visibly clean, stop pressing down. The CONTAINER RINSE VALVE will close and the spray will stop. Let the container drain until empty, then set it aside for proper recycling or disposal.
14. Operate the SIDEWALL RINSE SYSTEM for 30 additional seconds or longer to flush residues, and then close the SIDEWALL RINSE VALVE.

Using the optional Cleanload Suction Lance allows for loading of liquid chemicals and powders without lifting or pouring containers.

15. Ensure the hopper has been rinsed of chemical residue. Remove the hopper outlet screen by pulling it straight up from the outlet and set it aside.
16. Insert the lance body into the eductor until the o-ring seals on the hopper drain.
17. Use the end of the lance to pierce the bag or foil seal, and suction up the chemical.
18. When the desired amount of chemical has been suctioned up, raise the end of the lance slightly out of the chemical but keep it in the container to let the lance drain out.
19. Place the end of the lance into a container of clean rinse water. Suction for 30 seconds or more to clean the lance, and then raise the end slightly out of the water to let the lance drain back into the water container.
20. Point the end of the lance up and raise it above the hopper to drain any remaining water into the eductor. Ensure the hose is fully emptied into the eductor, then remove the lance from the eductor, and pour the container of rinse water into the hopper.
21. Reinstall the optional hopper outlet screen.

Start-Up, Operation, Shutdown - cont'd.

Shutdown

22. Ensure chemical residue has been flushed from the hopper, and the rinse system valves are closed.

NOTE Before shutdown, follow steps 8-14 using clean water to rinse the container and sidewall. For sprayers equipped with a clean water rinse tank, follow the sprayer manufacturer's instructions for pumping from the clean water tank during the final rinse. For transfer and tender truck installations, the final rinse should be made while transferring clean water.

23. Close the lid and lock it by turning it clockwise. Gently lift on the lid to ensure it is locked closed.

24. Close the HOPPER OUTLET VALVE.

25. Close the INLET VALVE.

26. If pump flow has been diverted to the Cleanload, divert it back for normal spraying or transfer.

Maintenance and Servicing

Information

ATTENTION: Divert or stop all flow to and from the Cleanload system before performing any service or maintenance procedures.

ATTENTION: Always wear proper Personal Protective Equipment when handling chemicals including gloves, eye protection, respirator and safety shoes.

ATTENTION: Always dispose of chemicals and contaminated water in accordance with national and local laws and statutes.

Cleaning

Always flush the Cleanload with clean water after each day's use, if switching chemicals, or if the system is going to be inactive for an extended period of time. Ensure that the components of the Cleanload are free of any chemical buildup or residue, both inside and out. Failing to properly clean the system could lead to reduced performance and component life.

Be sure to thoroughly clean the eductor, ball valves and hopper. Cycle the ball valves open and close during rinsing to ensure they are clean.

Maintenance

Daily Maintenance:

- Inspect all components for excessive wear, leaks or any other damage prior to each use. Careful inspection is required before using the system after long periods of inactivity.

Yearly Maintenance:

Your Cleanload will last longer and give best performance when properly taken care of. Proper Cleanload care depends on the fluid/chemical being used and when the Cleanload will be used again. At the end of the spraying season, flush the Cleanload with a neutralizing solution for the fluid/chemical just used. Follow with a clean water rinse. This is especially important for corrosive chemicals. Drain Cleanload thoroughly, open all drain plugs, and plug all ports until Cleanload is used again.

Parts Illustration

CAUTION: Only use Genuine Hypro replacement parts.

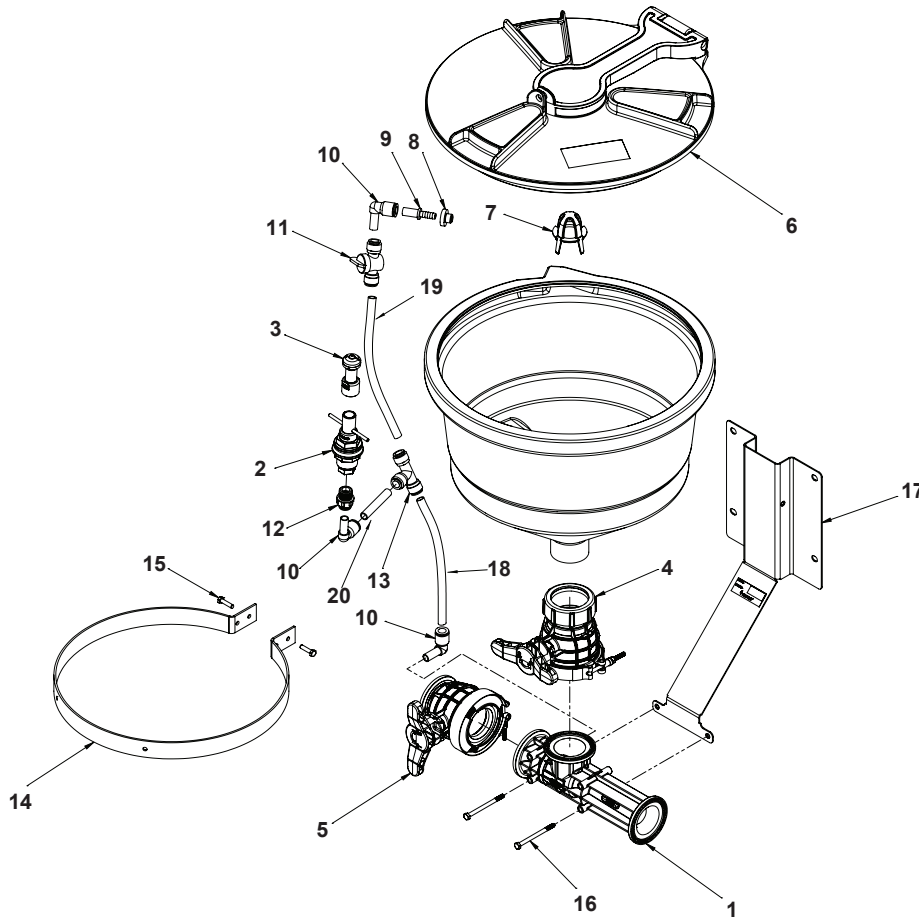

Ref. No.	Qty. Req'd.	Part Number	Description
1	1	3371-0036R	Eductor (for Model 3376-0870)
1	1	3371-0037R	Eductor (for Model 3376-0871)
1	1	3371-0038R	Eductor (for Model 3376-1170)
1	1	3371-0039R	Eductor (for Model 3376-1171)
1	1	3371-0040R	Eductor (for Model 3376-1670)
1	1	3371-0041R	Eductor (for Model 3376-1671)
2	1	PV1/2F1/2M-MA	ProClean Container Rinse
3	1	PC1/2F-36075	Nozzle, ProClean Container Rinse
4	1	7250-5000	Tank Valve
5	1	7250-5002	UF Valve
6	1	TL16-0006	Lid Kit
7	1	3350-0180	Strainer
8	1	1700-0253	Grommet
9	1	2404-0413	Hose Barb Fitting
10	3	2404-0414	Elbow Fitting (1/2")
11	1	3305-0113	Two-way Valve (1/2")
12	1	2404-0386	Fitting
13	1	2404-0415	Tee Fitting (1/2")
14	1	1510-0128	Mounting Ring
15	2	2210-0201	Hex Bolt, M6x1x25
16	2	2210-0200	Hex Bolt, M6x1x80
17	1	1510-0127	Bracket
18	1	2407-0007	Tube Kit
19	1	2407-0005	Tube Kit
20	1	2407-0006	Tube Kit

NOTE: When ordering parts, give quantity, part number, description and complete model number. Reference numbers are used ONLY to identify parts in the drawing and are NOT to be used as order numbers.

Tube kit No. 3430-0833 ~~Bold this line~~
 Contains: Tubing (Ref. 18)(Ref. 19)
 (Ref. 20) one screw not shown, one hose clamp not shown.

use
this p/n

Troubleshooting

Symptom	Cause	Solution
Slow Eduction Rate	Flow restrictions on outlet side of eductor.	Replace 90-degree fittings with sweeping bends using reinforced hose, especially near the eductor outlet. Use 2" (51mm) or larger hose and fittings all the way back to and into the tank. If sharp bends cannot be avoided, use oversized hose and fittings to minimize flow restriction.
	The eductor nozzle is plugged.	Looking down into the hopper outlet with the hopper valve open, observe the liquid jet should be centered and straight. If it is off-center or if it is dispersed, flush the system with clean water and remove the fittings from both sides of the eductor. Using a soft tool (wood or plastic) and taking care to not deform the orifice, clear the blockage by pushing it back out toward the inlet side of the fitting. A blocked eductor nozzle indicates that a filtration problem elsewhere in the system must be corrected.
Poor Lance Suction	Granules may be too coarse. the hopper.	Coarse product may need to be poured into
	Flow and pressure may be too low.	The lance functions best at the highest operating pressures. See action for "Slow Eduction Rate."
Plugged Container Rinse Nozzle	Debris in the Container Rinse system.	Replace nozzle and make sure there is proper filtration in the pump system before the Cleanload inlet.
Leaks	Loose fittings. Cracked fittings.	Tighten fittings. Replace fittings.

Notes

Limited Warranty on Hypro/SHURflo Agricultural Pumps & Accessories

Hypro/SHURflo (hereafter, "Hypro") agricultural products are warranted to be free of defects in material and workmanship under normal use for the time periods listed below, with proof of purchase.

- Pumps: one (1) year from the date of manufacture, or one (1) year of use. This limited warranty will not exceed two (2) years, in any event.
- Accessories: ninety (90) days of use.

This limited warranty will not apply to products that were improperly installed, misapplied, damaged, altered, or incompatible with fluids or components not manufactured by Hypro. All warranty considerations are governed by Hypro's written return policy.

Hypro's obligation under this limited warranty policy is limited to the repair or replacement of the product. All returns will be tested per Hypro's factory criteria. Products found not defective (under the terms of this limited warranty) are subject to charges paid by the returnee for the testing and packaging of "tested good" non-warranty returns.

No credit or labor allowances will be given for products returned as defective. Warranty replacement will be shipped on a freight allowed basis. Hypro reserves the right to choose the method of transportation.

This limited warranty is in lieu of all other warranties, expressed or implied, and no other person is authorized to give any other warranty or assume obligation or liability on Hypro's behalf. Hypro shall not be liable for any labor, damage or other expense, nor shall Hypro be liable for any indirect, incidental or consequential damages of any kind incurred by the reason of the use or sale of any defective product. This limited warranty covers agricultural products distributed within the United States of America. Other world market areas should consult with the actual distributor for any deviation from this document.

Return Procedures

All products must be flushed of any chemical (ref. OSHA section 1910.1200 (d) (e) (f) (g) (h)) and hazardous chemicals must be labeled/ tagged before being shipped* to Hypro for service or warranty consideration. Hypro reserves the right to request a Material Safety Data Sheet from the returnee for any pump/product it deems necessary. Hypro reserves the right to "disposition as scrap" products returned which contain unknown fluids. Hypro reserves the right to charge the returnee for any and all costs incurred for chemical testing, and proper disposal of components containing unknown fluids. Hypro requests this in order to protect the environment and personnel from the hazards of handling unknown fluids.

Be prepared to give Hypro full details of the problem, including the model number, date of purchase, and from whom you purchased your product. Hypro may request additional information, and may require a sketch to illustrate the problem.

Contact Hypro Service Department at 800-468-3428 to receive a Return Merchandise Authorization number (RMA#). Returns are to be shipped with the RMA number clearly marked on the outside of the package. Hypro shall not be liable for freight damage incurred during shipping. Please package all returns carefully. All products returned for warranty work should be sent **shipping charges prepaid** to:

HYPRO / PENTAIR
Attention: Service Department
375 Fifth Avenue NW
New Brighton, MN 55112

For technical or application assistance, call the **Hypro Technical/Application number: 800-445-8360**, or send an email to: **technical@hypropumps.com**. To obtain service or warranty assistance, call the **Hypro Service and Warranty number: 800-468-3428**; or send a fax to the **Hypro Service and Warranty FAX: 651-766-6618**.

*Carriers, including U.S.P.S., airlines, UPS, ground freight, etc., require specific identification of any hazardous material being shipped. Failure to do so may result in a substantial fine and/or prison term. Check with your shipping company for specific instructions.



375 Fifth Avenue NW • New Brighton, MN 55112
Phone: (651) 766-6300 • 800-424-9776 • Fax: 800-323-6496
www.hypropumps.com