

Please read and save this Repair Parts Manual. Read this manual and the General Operating Instructions carefully before attempting to assemble, install, operate or maintain the product described. Protect yourself and others by observing all safety information. The Safety Instructions are contained in the General Operating Instructions. Failure to comply with the safety instructions accompanying this product could result in personal injury and/or property damage! Retain instructions for future reference.

SHURflo Heavy-Duty Cast Iron and Bronze Pedestal Rotary External Gear Pumps

Refer to form L-4082 for General Operating and Safety Instructions and Applicable Warranty.

Description

SHURflo self-priming, positive displacement, external rotary gear pumps operate bi-directionally (reversible) and are ideal for a wide range of industrial, marine, agricultural, and commercial applications. They provide a nearly pulseless flow where non-abrasive and non-particulated fluids are pumped.

Quality features include a keyed drive shaft supported by heavy-duty ball bearing, large bushing support and an adjustable pressure relief valve that can be ported internally or externally. Motor HP recommendations are listed in the performance chart.

Uses: For use with non-particulate and non-abrasive fluids compatible with pump wet-end construction component materials.

- Capacities up to 24.8 GPM.
- Maximum pressure to 125 PSI and working casing pressure to 200 PSI.
- Max. RPM: 1725.
- Suction lift to 19.5 ft.
- Temperatures from -20° to 280° F.
- Large female NPT ports allow use with viscous fluids.
- Pumps can be long-coupled with electric motors to handle up to 500 SSU at 1725 RPM or run at reduced speeds to handle a wide range of pump fluid specific gravities and viscosities up to 100,000 SSU. (Maximum torque loads are found in the performance chart.)
- Mechanical seals (Viton, Teflon® or Buna) with carbon on ceramic faces with engineered flush chamber for internal or external flush to handle viscosities beyond 2000 SSU.
- Pumps can operate bi-directionally (reversible).
- Ball bearing shaft support allows for pulley drive.
- Standard adjustable pressure relief valves that can be internally or externally ported.

BRONZE MODELS – Excellent for water-based fluids. Ryton PPS (Polyphenylene Sulfide) spur gears provide quiet operation and chemical compatibility. No metal-to-metal contact. Pumps have 303 stainless steel shafts and carbon graphite bushings. Buna-N mechanical seal with carbon on ceramic faces has a temperature range of -20° to 210° F. Wet-end parts are constructed from bronze, brass, Ryton PPS, stainless steel (17-7, 303 and/or 18-8), graphite, carbon, ceramic, vellumoid, and Buna-N.

CAST IRON MODELS – These pumps are specifically designed to be used with oil-based fluids, not to be used with water-based fluids. Pumps include steel spur gears with steel shafts and cast iron shaft support. Viton mechanical seal with carbon on ceramic faces has a temperature range of 32° to 280° F. Wet-end parts are constructed from cast iron, steel, stainless steel (17-7, 303 and/or 18-8), carbon, ceramic, Viton, and vellumoid.

REPAIR SEALS AND OPTIONS – Standard seals are Viton and Buna-N with carbon on ceramic faces. An optional Teflon® seal of 316 SS construction with carbon on ceramic faces is available. Standard seals can be located in the repair parts list pages in this manual. When ordering optional mechanical seals, be sure to order the optional o-rings in the same material. These can be found in the repair parts section in this manual.

NOTE: This series of gear pumps is also available as close-coupled models equipped with motors.



WARNING: Do not use to pump flammable or explosive fluids such as gasoline, fuel oil, kerosene, etc. Do not use in flammable and/or explosive atmospheres. When pumping hazardous or dangerous materials, use only in a room or area designated for that purpose. For your protection, always wear proper clothing, eye protection, etc. in case of any malfunction. For proper handling techniques and cautions, contact your chemical supplier, insurance company and local agencies (fire dept., etc.). Failure to comply with this warning could result in personal injury and/or property damage.

SHURflo Heavy-Duty Cast Iron and Bronze Pedestal Rotary External Gear Pumps

Model Ordering Codes and Options



Example Model: GPBN5V (will require 2 HP ODP motor with >1.15 Service Factor*)
(motor not supplied with pedestal pump)

1st Mounting	2nd Material	3rd Seal (Mech)	4th Gear** Size: Ports	5th Options
GP: Gear Pedestal	B: Bronze Cl: Cast Iron	N: Buna-N V: Viton T: Teflon	2: 3/8" 3: 1/2" 4: 3/4" 5: 1" 6: 1 1/4"	V: Pressure Relief Valve (standard)

NOTE: Not all order code combinations (configurations) are standard models available from the manufacturer. Custom model configurations may require ordering standard components and/or optional parts that will need to be assembled by the customer.

Manufacturer reserves the right to change model order codes, standard models, specifications, and performance without notification.

(*) ODP motors have > 1.15 service factors. Due to service factor, it is recommended TEFC motors are oversized by one HP increment.

Pedestal Pumps are not supplied with a motor.

(**) Bronze models have Ryton PPS (Polyphenylene Sulfide) gears. Cast Iron models have steel gears.

Maximum motor speed is 1725 RPM.

Cast iron is not for use with water-based fluids.

Bronze Models GPBN2V thru GPBN6V Cast Iron Models GPCV2V thru GPCV6V

Performance (Standard Models)

Pump Model	*Port Size	Max. Input Torque in.-lbs.	Pump RPM	Suction** Lift (ft)	GPM Pumping 10 Wt. Oil at 70° F (500 SSU)											
					Free Flow		25 PSI		50 PSI		75 PSI		100 PSI		125 PSI	
					GPM	HP	GPM	HP	GPM	HP	GPM	HP	GPM	HP	GPM	HP
GPBN2V GPCV2V	3/8	45	900	1.5	2.5	1/4	2.5	1/4	2.4	1/4	2.3	1/4	2.1	1/4	1.8	1/3
			1200	2.2	3.3	1/4	3.3	1/4	3.2	1/4	3.1	1/3	2.9	1/3	2.6	1/2
			1725	3.5	4.8	1/4	4.8	1/3	4.7	1/2	4.6	1/2	4.4	3/4	4.3	3/4
GPBN3V GPCV3V	1/2	90	900	2.8	3.7	1/4	3.6	1/3	3.5	1/3	3.4	1/2	3.2	1/2	2.8	3/4
			1200	5.7	4.9	1/4	4.8	1/3	4.7	1/2	4.6	1/2	4.4	3/4	4.0	3/4
			1725	7.9	7.0	1/2	6.9	1/2	6.8	3/4	6.7	1	6.5	1	6.1	1½
GPBN4V GPCV4V	3/4	90	900	5.1	5.6	1/3	5.5	1/3	5.4	1/2	5.3	3/4	5.0	1	4.5	1
			1200	6.7	7.5	1/3	7.4	1/2	7.3	3/4	7.2	1	6.9	1	6.4	1½
			1725	12.3	10.8	1/2	10.7	3/4	10.6	3/4	10.5	1	10.2	1½	9.7	1½
GPBN5V GPCV5V	1	160	900	6.6	10.8	1/2	10.6	3/4	10.5	3/4	10.4	1	10.0	1	9.4	1½
			1200	9.3	14.3	1/2	14.2	3/4	14.1	1	13.9	1½	13.5	1½	12.9	2
			1725	15.2	20.6	3/4	20.5	1	20.3	1½	20.2	2	19.8	2	19.2	3
GPBN6V GPCV6V	1¼	160	900	8.1	12.6	1/2	12.5	3/4	12.3	1	12.1	1	11.7	1½	11.1	1½
			1200	11.7	16.7	3/4	16.6	1	16.4	1½	16.2	1½	15.8	2	15.2	2
			1725	19.5	24.8	3/4	24.7	1	24.5	1½	24.3	2	23.9	3	23.3	3

Test data taken on SAE 10 wt. oil at 70° F (500 SSU).

Performance in water will decrease by about 10%, and HP required will also be reduced by 10%. (Don't use water with Cast Iron.)

Pump performance when pump is new. As pump wears, the performance will decrease.

(*) Female NPT inlet and outlet (in inches).

(**) Suction lift requires wetted gears and primed seal chamber.

NOTES: Max. PSI = 125

Max. Viscosity = 500 SSU at 1725 RPM with standard spur gears

Max. RPM = 1725

Max. Specific Gravity = 1.1 at 125 PSI, up to 1.6 at lower PSI & viscosity.

Max. Input Torque = See chart above.

Reverse Rotation = Pumps are equipped with pressure relief valves and can be run in reverse rotation; however, pressure relief valve will not function when pump is reversed unless pump relief valve cover is rotated 180°.

The pump relationship between volume (GPM), pressure (PSI), speed (RPM) and horsepower is shown on performance chart in Shurflo Motor Manual form L-4082. When pumping a more viscous liquid, a slower speed, a larger pipe size pump, and possibly a larger motor should be selected.

Manufacturer reserves the right to change performance without notification.

SHURflo Heavy-Duty Cast Iron and Bronze Pedestal Rotary External Gear Pumps

Specifications (Standard Models)

Model	Max. RPM	NPT Inlet & Outlet Port (inches)	PUMP CONSTRUCTION (Wet End)					Shaft, Keys & Clips	Pressure Relief Valve*	O-Rings & Seals**	Ship Wt. (lbs.)
			Body & Cover Castings	Gear Material	Gasket Material	Bushing Material					
Bronze Models											
GPBN2V	1725	3/8	Bronze	Ryton	Vellumoid	CG	303 SS	BR & SS	Buna-N	10.5	
GPBN3V	1725	1/2	Bronze	Ryton	Vellumoid	CG	303 SS	BR & SS	Buna-N	11.2	
GPBN4V	1725	3/4	Bronze	Ryton	Vellumoid	CG	303 SS	BR & SS	Buna-N	12.8	
GPBN5V	1725	1	Bronze	Ryton	Vellumoid	CG	303 SS	BR & SS	Buna-N	19.8	
GPBN6V	1725	1¼	Bronze	Ryton	Vellumoid	CG	303 SS	BR & SS	Buna-N	22.8	
Cast Iron Models											
GPCV2V	1725	3/8	CI	Steel	Vellumoid	CI	Steel	Steel & SS	Viton	11.2	
GPCV3V	1725	1/2	CI	Steel	Vellumoid	CI	Steel	Steel & SS	Viton	12.6	
GPCV4V	1725	3/4	CI	Steel	Vellumoid	CI	Steel	Steel & SS	Viton	13.4	
GPCV5V	1725	1	CI	Steel	Vellumoid	CI	Steel	Steel & SS	Viton	18.7	
GPCV6V	1725	1¼	CI	Steel	Vellumoid	CI	Steel	Steel & SS	Viton	19.0	

Ryton = PPS (Polyphenylene Sulfide) SS = Stainless Steel CG = Carbon Graphite CI = Cast Iron BR = Brass

(*) Bronze models are made of brass and/or bronze and stainless steel (302, 303 and/or 18-8). Cast Iron models are made of cast iron, steel and stainless steel (302, 303 and/or 18-8).

(**) Made from 18-8 stainless steel and carbon on ceramic seal faces. O-rings are Buna-N or Viton to match the seal type.

NOTE: Manufacturer reserves the right to change specifications without notification.

Bronze Models GPBN2V thru GPBN6V Cast Iron Models GPCV2V thru GPCV6V

Dimensions (inches)

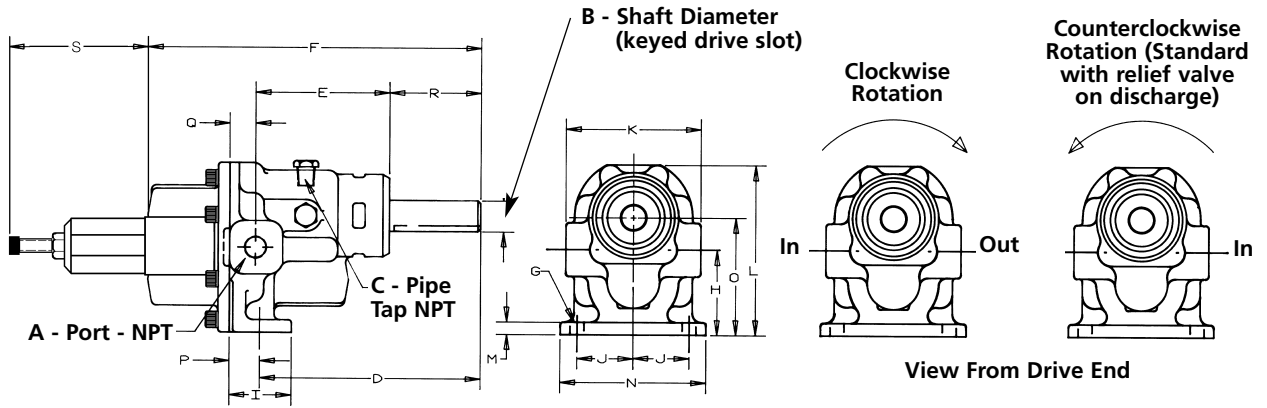

Figure 1

Model Numbers	Port Shaft		Dimensions (in inches)																
	A*	B**	C*	D	E	F	G	H	I	J	K	L	M	N	O	P	Q	R	S
GPBN2V, GPCV2V	3/8	1/2	1/8	3.91	2.70	6.38	.281	1.71	1.26	1.130	2.73	3.42	0.25	2.94	2.36	0.81	0.520	1.50	2.98
GPBN3V, GPCV3V	1/2	5/8	1/8	4.66	2.90	7.11	.391	1.88	1.26	1.440	3.26	3.75	0.26	3.63	2.63	0.75	0.625	1.88	2.93
GPBN4V, GPCV4V	3/4	5/8	1/8	5.03	3.18	7.48	.391	1.88	1.26	1.440	3.26	3.75	0.26	3.63	2.63	0.75	0.625	1.88	2.94
GPBN5V, GPCV5V	1	3/4	1/8	5.79	3.60	8.46	.391	2.56	1.74	1.625	4.00	5.13	0.26	4.00	3.56	0.94	0.880	2.25	3.16
GPBN6V, GPCV6V	1 1/4	3/4	1/8	6.04	3.69	8.70	.391	2.56	1.74	1.625	4.06	5.13	0.26	4.00	3.56	0.94	1.040	2.25	3.17

(*) Female NPT inlet and outlet ports (in inches).

(**) Shaft is slotted for key.

NOTE: Manufacturer reserves the right to change dimensions without notification.

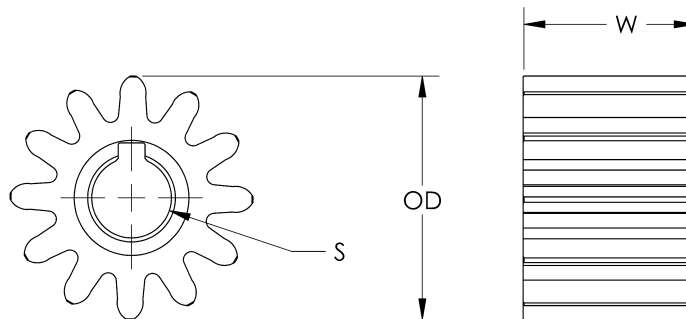

Gear Part Numbers and Dimensions (in inches)

Gear-Ryton (PPS)-Black Spur	13879	21137	12764	21136	13883
Gear-Steel Spur	21456	21157	21458	21459	21460
Gear Outside Diameter (OD)	1.50	1.75	1.75	2.33	2.33
Gear Width (W)	0.75	0.88	1.25	1.25	1.50
Shaft Size (S)	0.50	0.63	0.63	0.79	0.79

Ryton PPS (Polyphenylene Sulfide)

NOTE: Manufacturer reserves the right to change dimensions without notification.

Figure 2 - Gear Identification and Dimension Chart

SHURflo Heavy-Duty Cast Iron and Bronze Pedestal Rotary External Gear Pumps

⚠ WARNING Check motor. It may be equipped with an automatic resetting thermal protector and may restart unexpectedly (see specifications chart). Protector tripping is an indication of motor overloading as a result of operating the pump at too high a pressure (over 125 PSI), too high of viscosity, too high of specific gravity, excessively high or low voltage, inadequate wiring, incorrect motor connections, too small a motor (sized incorrectly, not enough HP), or a defective motor or pump.

Do not handle pump with wet hands or when standing in water. Failure to follow the General Safety Information and all warnings could result in fatal electrical shock!

Installation

IMPORTANT: In any installations where property damage and/or personal injury can occur when the pump is not operating due to power outages, discharge line freezing, or any other reason, a back-up system(s) and/or warning system(s) should be used.

In order to safely use this product, familiarize yourself with this pump and also with the liquid (chemical, etc.) that is going to be pumped through the unit. This pump is not suitable for many liquids.

1. Locate the pump as close to the liquid source as possible, making the suction line as short and direct as possible.

PIPING

SUCTION

2. Avoid excessive lengths or number of fittings and bends in the suction line.
3. Attach suction line to suction inlet.
4. It is recommended that same size pipe as pump ports be used or, in cases requiring lengthy piping, the next larger size pipe be used.
5. If suction lift is greater than what is indicated in the performance chart, attach a foot valve below liquid

level at end of suction line to ensure positive priming. Also note: If fluid specific gravity is greater than 1.4 or viscosity greater than 500 SSU, a foot valve is also recommended.

NOTE: If a foot valve (or check valve) is not used in the suction line, it may be necessary to refill the pump every time the unit is stopped and you wish to restart the pump. This depends on the length of time between starts and whether or not the gears are wet enough to close cavities to affect a prime.

6. If solid contaminants are suspected in a liquid, place a filter in the suction line.
7. Be certain all suction piping connections are airtight.

NOTE: Assure airtight pipe connections with the use of a pipe joint sealant.

DISCHARGE

8. Attach discharge piping to the discharge outlet.

⚠ WARNING Support pump and piping during assembly and after installation. Failure to do so may cause piping to break, pump to fail, motor bearing failures, etc., all of which can result in property damage and/or personal injury.

NOTE: Should the pump need to be self-draining, the pump head should be mounted in the vertical position with the suction port facing down. When pumping high viscosity fluids, the vertical position can be used with the suction port facing up and the pump mounted under the source. Increasing the suction pipe size and eliminating bends and elbows also assists in pumping high viscosity fluids. Max. viscosity is 500 SSU at 1725 RPM.

9. If a shut-off valve or handgun is required in discharge line, provide a pressure relief valve for pump protection.

⚠ WARNING Shutting off discharge without providing pressure relief can cause extreme over pressure which can result in pump and/or motor failure. Do not exceed 125 PSI pump or system pressure.

10. Operation under shut-off discharge conditions will overheat and damage pump.

NOTE: Globe valve or other restrictive valves should not be used as shut-off mechanism as they are restrictive in nature and will seriously affect pump performance.

11. After all piping and controls (not supplied with unit) have been installed, unit is ready for operation.

Operation

⚠ CAUTION Do not run pump dry, as permanent damage to the pump gears, seal, and bearings will result. Suction pressure should never be greater than the discharge pressure.

1. All pumps must be primed before start-up and the seal chamber needs to be filled (See Figure 3). Never operate a pump unless it is secured to a solid foundation and all safety shields are installed.

Upon start-up, maintain a minimum of 15 PSI (1 BAR) operating pressure on the pump. This will allow any remaining air to be driven from the seal chamber and will ensure liquid circulation to the mechanical seal.

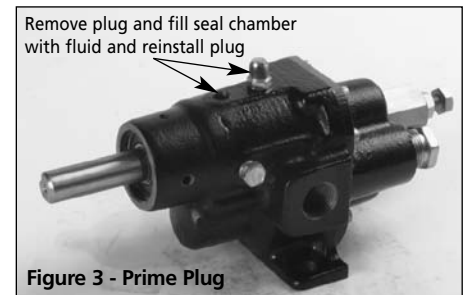

Figure 3 - Prime Plug

Bronze Models GPBN2V thru GPBN6V Cast Iron Models GPCV2V thru GPCV6V

Operation (Continued)

2. Gear pumps are built to very close tolerances and this tolerance must not be altered. The liquids must, therefore, be free of all abrasives. Sand, silt, wettable powders, etc. must be avoided.

NOTE: Cast iron pumps are for oil-based fluids only.

3. When pumping a more viscous (beyond 500 SSU) liquid; a slower speed, a larger pipe size pump, and possibly a large motor should be selected.

NOTE: See performance chart for Max. Torque.

4. Recheck motor and pump rotation. Proper pump rotation is counter-clockwise (CCW) looking at the drive shaft when pressure relief valve is installed by manufacturer (See Figure 1).
5. On all standard models, pressure relief valve is always on discharge side (See Figure 1).

PRESSURE RELIEF VALVE

6. Standard model rotary gear pumps are supplied with a built-in internal pressure relief valve (can be externally ported). The valve may be adjusted and used to set system operating pressure, or used as a system pressure relief valve to prevent pump and motor damage that can occur when discharge line is closed off. This relief valve is not factory set. Extended operation (over one minute) under shut-off conditions could cause pump to overheat, leak, and damage itself or overload motor.

7. To increase the pressure relief valve pressure setting, loosen lock nut (Ref. No. 29), then turn the set screw (Ref. No. 28) in (clockwise).

Turning the set screw out (counter-clockwise) will reduce the pressure setting. When desired pressure is achieved, tighten lock nut and reinstall protective cap (See Figure 4).

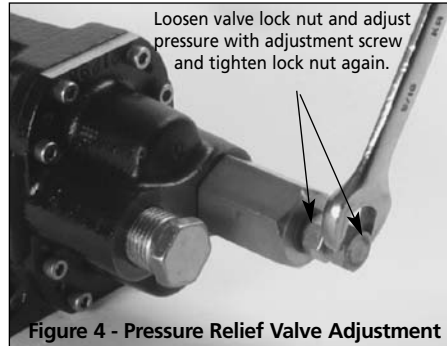

Figure 4 - Pressure Relief Valve Adjustment

8. The pressure relief valve can be converted to an external relief. This will allow the relief to dump back to tank and allow longer periods of relief without pump damage. However, this is not a full-line relief valve, and in cases where frequent extended relief valve operation is anticipated, a full-line external relief valve should be piped in the discharge line and connected either back to the tank or well downstream of the pump suction inlet (See Figure 5).

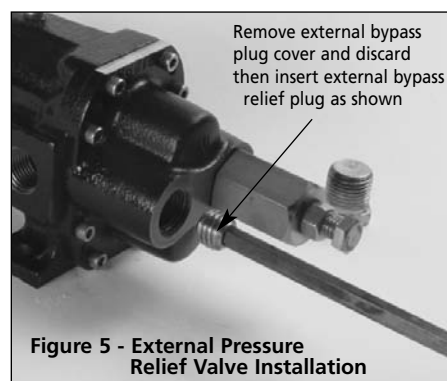

Figure 5 - External Pressure Relief Valve Installation

9. To convert the relief valve to external relief, remove the NPT pipe plug from the pump cover (Ref. No. 30)

and discard. This plug is next to the relief valve. In the bottom of the NPT hole, there is a second drilled and tapped hole. An optional external bypass plug (Ref. No. 31 included) should be inserted in this hole and bottomed out. The open NPT port must now be piped back to the tank or well downstream of the pump suction (See Figure 5).

10. Standard models are equipped with pressure relief valves, and the pump can be run in reverse, however, the pressure relief valve will not function. For continuous reverse rotation, the cover plate must be rotated 180°. This is accomplished by removing the eight cover plate screws, rotating the cover plate, and reattaching the screws. The pressure relief valve should now be on the opposite side. This will allow operation of the pump with a functioning pressure relief valve in reverse rotation.

GEAR PUMP GASKET ADJUSTMENT FOR TEMPERATURE (See Appendix 1)

11. For operation in fluid temperatures above 120° F, bronze pump models must have the gasket thickness adjusted (not necessary for cast iron models). Use Appendix 1 to identify pump, temperature and gasket recommendations for adjusting the cover clearance prior to operation in elevated temperatures or viscosities above 500 SSU.

CAUTION Failure to adjust pump cover clearances for operating temperatures above 120° F will result in severe pump and/or motor damage.

NOTE: When pumping fluids of high viscosity (>500 ssu), the required torque and HP can be reduced by adding a gasket for increased gear clearance.

SHURflo Heavy-Duty Cast Iron and Bronze Pedestal Rotary External Gear Pumps

Operation (Continued)

DRIVE CONNECTIONS

NOTE: Pedestal Gear Pumps will operate equally well in either direction. When looking at the pump drive shaft end and rotating the shaft clockwise, the discharge port is on the right-hand side. When turning counterclockwise, the discharge port is on the left-hand side.

DIRECT COUPLING DRIVES

Never use a rigid coupling between the pump and the motor. Some degree of flexibility must be allowed at the coupling to avoid excessive side loading of the motor and pump bearings. Any flexible coupling rated for the horsepower load and speed is satisfactory. Care should be taken that the pump and motor shaft are in alignment. Misalignment will cause unnecessary loads on the pump and motor bearings.

NOTE: Unit is not recommended for direct drive by engine (gasoline or diesel). If engine drive is desired, a "V"-belt arrangement is recommended to reduce torque pulsations on the pump.

PULLEY DRIVE

In some cases, a reduction in pump speed is essential. This may be accomplished through a belt and pulley drive. Bear in mind, however, that belt tension adds a side thrust to the pump drive shaft which results in extra bearing loading and wear with resulting shortened pump life. Adjust belt tension to belt manufacturers' recommendations.

12. For pulley-driven pumps, a single 1/2 (A or 4L section) "V" belt is satisfactory for drive sizes and speeds up to 1 HP, 3450 RPM. For larger drive sizes, double "V" belts are recommended. Maximum pump RPM is 1725.

13. Install safety guards, shield, etc., around all moving parts.

▲ WARNING *Failure to install proper safety guards, shields, etc. can result in property damage and/or personal injury. Follow all electrical and safety codes, as well as United States National Electrical Code (NEC) and Occupational Safety and Health Act (OSHA).*

14. When using an electric motor, make necessary electrical connections for the voltage outlet supply and double-check all connections. Check power connections for proper voltage. (Refer to wiring diagram on motor nameplate or inside the terminal box for the proper connections.) See General Safety Information.

IMPORTANT: Electrical circuit must be properly fused.

MECHANICAL SEAL FLUSH INSTALLATION OPTIONS

15. These bronze and cast iron pumps are equipped with mechanical seals and have been designed with flush ports because mechanical seals require cooling lubrication for long life.

a. For fluids with viscosities less than 2000 SSU, a flush is not necessary, but the seal cavity must be pre-filled with either the operating fluid or a neutral fluid. This is to ensure seal cooling and lubrication during start-up (See Figure 3).

▲ CAUTION *Failure to provide initial seal prime can result in the mechanical seal overheating with resulting repair costs.*

b. For high viscosity fluids, a flush will be necessary. The seal must be cooled and lubricated by a fluid. In the case of high viscosity fluids, due to the precision clearances between the gear teeth and the bronze or cast iron body, highly viscous fluids will not be able to adequately relieve the air in the seal cavity on start-up. The

dry running of a mechanical seal will cause rapid failure. A flush must be provided for fluids with a viscosity of greater than 2000 SSU.

▲ CAUTION *Pumping fluids with viscosities greater than 2000 SSU requires flushing the seal chamber during operation, otherwise seal damage will occur.*

EXTERNAL FLUSH

An external flush system is typically recommended for applications where crystallization build-up on the seal is possible. Some dilution of the working material must be acceptable to use an external flush system.

The external flush system (See Figure 6 for typical installation) is commonly used with liquids where city water can be used as the neutral flush fluid. City water is taken from an external source such as a tap, hose, or special plumbing fixture and is regulated into the seal cavity by means of a needle valve and flow meter. Use of an anti-siphon check valve is required.

▲ WARNING *It is essential that an anti-siphon check valve be installed between the pump and the city water supply to prevent any back flow from possibly contaminating the city water supply. Failure to do so could result in contamination of the water supply with consequential damages. Manufacturer assumes no responsibility for failure of user in not providing safeguards to city water systems.*

Step 1: Locate appropriate city water supply and install anti-siphon check valve.

Step 2: Use appropriate pipe nipple to reduce piping to 1/8".

Step 3: Install appropriate needle valve and flow meter.

Step 4: Connect piping to one of three available seal flush ports on pump.

Step 5: Adjust needle valve to achieve desired flow to seal cavity (recommended 1 to 3 GPH).

Bronze Models GPBN2V thru GPBN6V Cast Iron Models GPCV2V thru GPCV6V

Operation (Continued)

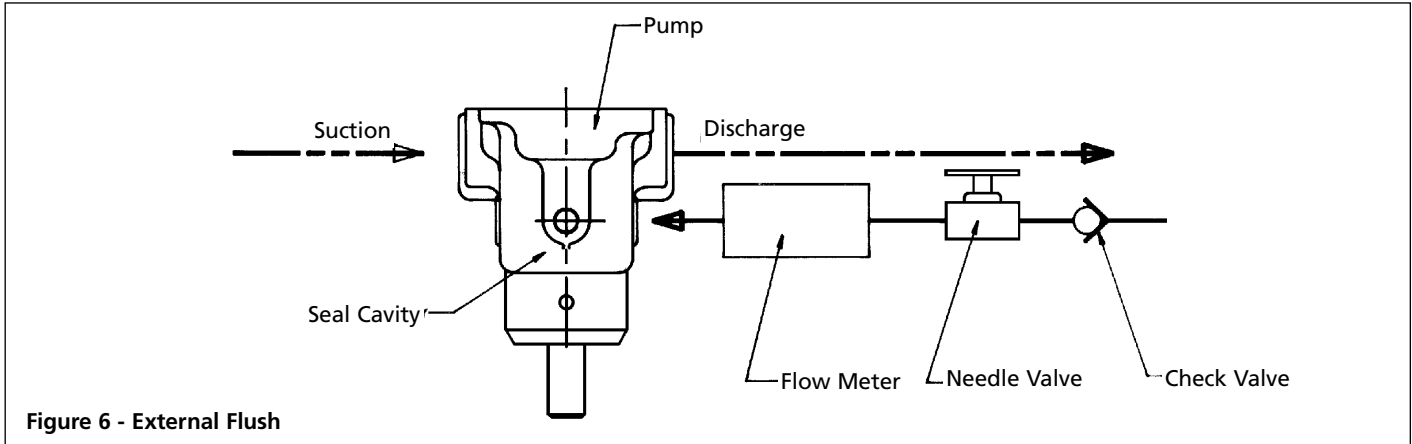

Figure 6 - External Flush

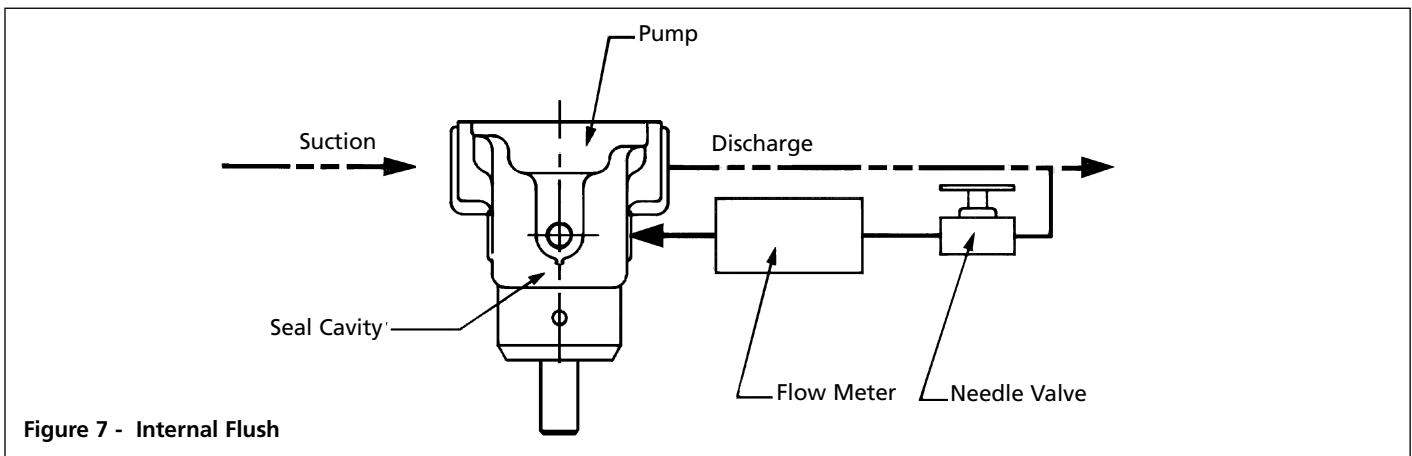

Figure 7 - Internal Flush

INTERNAL FLUSH

Similar to above but internal supply (See Figure 7 for typical installation). Typically recommended for high viscosity applications ensuring lubrication to the mechanical seal.

In an internal flush system, the fluid is taken from the discharge and regulated from 1 to 3 GPH (Gallon Per Hour) to the seal cavity by means of a flow meter and needle valve.

Step 1: Select a T pipe coupling that is consistent with discharge pipe size and material. Couple to discharge piping.

Step 2: From this coupling, attach a needle valve with appropriate nipple reducing to 1/8" pipe or tube. Install appropriate flow meter.

Step 3: Connect 1/8" pipe or tube to one of three available seal cavity flush ports.

Step 4: Adjust needle valve to desired flow into seal cavity, (recommended 1 to 3 GPH).

CAUTION For alternate flush systems for hazardous fluid applications, hot liquid transfer, and those not addressed in this booklet, consult a qualified fluid handling specialist for assistance in specifying and installing flush systems according to local, state and federal environmental laws.

NOTE: Gears must be replaced as a set.
16. Unit is ready for operation.

SHURflo Heavy-Duty Cast Iron and Bronze Pedestal Rotary External Gear Pumps

Maintenance

⚠ WARNING *Make certain that the power source is disconnected before attempting to service or disassemble any components!*

If the power disconnect is out of sight, lock it in the open position and tag to prevent application of power.

CLEANING

Clean the suction line filter at regular intervals.

ELECTRIC MOTOR (NOT SUPPLIED)

Properly selected and installed, electric motors are capable of operating for years with minimal maintenance. Periodically clean dirt accumulations from open-type motors, especially in and around vent openings, preferably by vacuuming (avoid imbedding dirt in windings). Oil and maintain as recommended by motor manufacturer.

GENERAL

Check the pump to motor shaft alignment at regular intervals.

Periodically check that electrical connections are tight. Pump should be drained if placed in an area that is subject to freezing temperatures.

PUMP REPAIR

DISASSEMBLY

1. (Refer to Figure 13 for Reference Numbers and Figures 8, 9, 10, 11 & 12 for detailed seal and shaft assemblies.)

a. Remove cover plate (Ref. No. 20) (held by eight screws) and gasket (Ref. No. 2) if needed. Gently tap cover plate with rubber mallet to free it from dowel pins. Once cover is removed, the idler shaft and gear assembly can be pulled out of pump body (Ref. No. 9).

b. Remove the idler gear (Ref. No. 3) from the shaft (Ref. No. 6) by removing retaining rings (Ref. No. 4), then slide gears off the shaft end (Ref. No. 6).

c. The drive gear (Ref. No. 4) can be pulled out. Before drive shaft (Ref. No. 5) can be removed from body (Ref. No. 9), remove woodruff key (Ref. No. 7) by gently tapping key with drift pin. (Do not damage key or keyway upon removal.)

2. From the drive shaft end of the gear pump, remove the internal snap ring (Ref. No. 18) from the body

(Ref. No. 9). The drive assembly, which consists of the drive shaft (Ref. No. 5), seal assembly (Ref. Nos. 13 & 14), seat retainer (Ref. No. 15), bearing (Ref. No. 17) and retaining rings (Ref. No. 12), can now be removed from the unit (See Figure 8). Also remove the internal o-ring (Ref. No. 16) from the body.

REASSEMBLY

(Refer to Figure 13 for Reference Numbers and Figures 8, 9, 10, 11 & 12 for detailed seal and shaft assemblies.)

1. Shaft/Seal Assembly

a. Install inside o-ring (Ref. No. 16) into body (Ref. No. 9). Lubricate with water on bronze models and oil on cast iron models.

b. There are two possible types of seals. One style, the seal is one piece while the other style has a seal boot, spring and spring retainer. The seal seats can also be of two styles; one has a rubber boot and the other has an o-ring. Identify which type you have (See Figure 10). (For the optional Teflon seal, see the following note and Figure 12.)

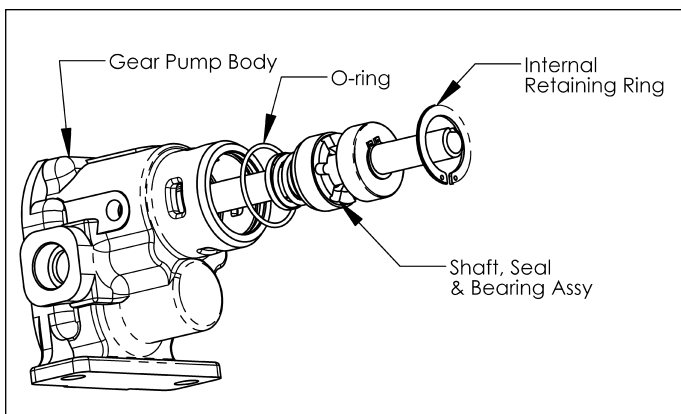

Figure 8 - Shaft, Seal and Bearing Assembly

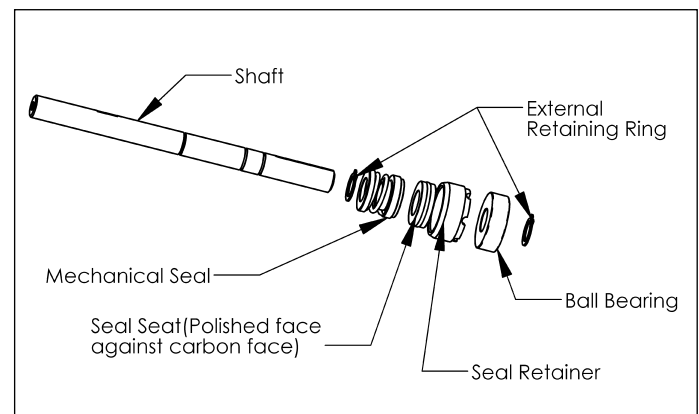

Figure 9 - Shaft, Seal and Bearing Assembly (detailed view)

Bronze Models GPBN2V thru GPBN6V Cast Iron Models GPCV2V thru GPCV6V

- c. Refer to assembling components on drive shaft (See Figure 9). When installing the seal on the shaft, wet with water and be cautious when sliding it into position. The spring retaining washer and spring are behind the seal with the carbon ceramic facing towards the keyed end of drive shaft (See Figure 9).
- d. Press seal seat into the seal retainer (See Figure 11) using water as a lubricant. The white shiny ceramic face should be visible after pressing the seal into the seal retainer. It is recommended to use a cardboard washer or wood dowel when pushing the seal seat into the seal seat retainer. Any scratches, dirt, or fingerprints on the carbon ceramic faces will cause the seal to leak. The seal seat is stationary in the pump, while the seal on the shaft rotates, providing for the sealing surface.

NOTE: When installing the seat for the optional Teflon seal, an anti-rotation pin must be installed into the seat retainer. The anti-rotation pin (Ref. No 32) is a small spring pin which must be installed into the seat retainer in the

small hole. About 1/8" to 3/16" of the pin should be exposed inside of the seat retainer (Figure 11). The seal seat is then installed into the seat retainer.

IMPORTANT! The notch on the back of the seat retainer must be aligned to the anti-rotation pin when pressing the seat into place.

NOTE: When installing the optional Teflon seal, the procedure is modified. The seat retainer/seal seat/anti-rotation pin assembly is then placed over the shaft assembly and against the ball bearing. The polished face of the ceramic should be showing. The mechanical seal comes with several "C" clips on either side (See Figure 12).

The purpose of these clips is to establish

the correct seal compression. These are removed only in the very last step of the operation. Do not remove these clips until the last step. Failure to do this will prevent correct installation of the Teflon seal with resulting leakage and or immediate failure of the seal. Note that the working height of the Teflon seal is different than that of either the Viton or Buna-booted seals. As such, the seal will not align to or use the retaining ring. Discard the retaining ring (Ref. No. 12) that was behind the standard seal that came with the pump. The mechanical seal is placed on the shaft with the polished carbon face against the polished ceramic of the seat. Do not use any lubricants when installing the seal other than very clean water. The use of lubricants can cause weeping of the mechanical seal Teflon wedges. Make sure that all of these components are installed tight against each other (ball bearing, seat retainer with seat, and the mechanical seal). (See Figures 8 and 9.)

Tighten the set screws on the mechanical seal so that it is tight to the shaft (See Figure 12). Now remove the "C" clips from the seal to actuate the springs and spring tension on the seal face. The seal is now installed. Unlike

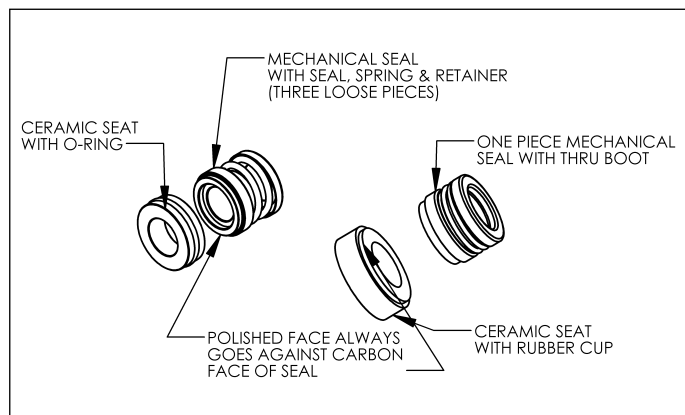
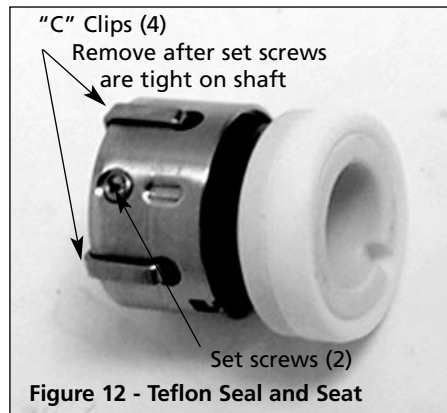

Figure 10 - Seal Types and Parts Identification

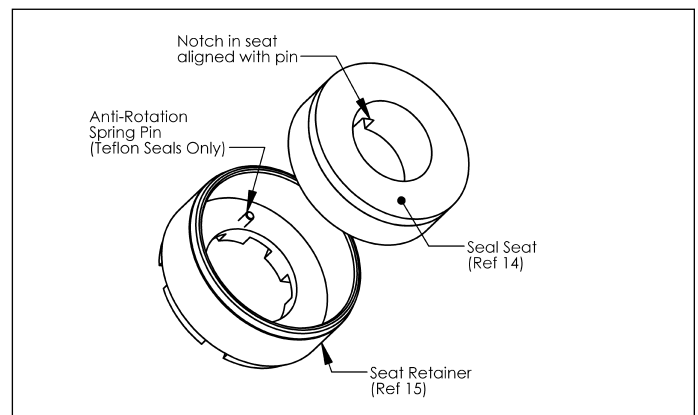

Figure 11 - Seal Seat and Retainer Assembly

SHURflo Heavy-Duty Cast Iron and Bronze Pedestal Rotary External Gear Pumps

Maintenance (Continued)

the “boot” seals in Viton and Buna, an external retaining ring (Ref. No. 12) is not required to hold the seal. The set screws accomplish that. The Teflon mechanical seal is shorter than the booted seal. As such, it will not extend all of the way to the retaining ring groove. This is normal.

- e. Slide the seal retainer and bearing onto the drive shaft and install retaining ring, holding the bearing and seal onto the shaft (See Figures 8 and 9).
- f. Slide the drive shaft assembly (Ref. Nos. 5,12,13,14,15 & 17) into the gear pump body and secure with the internal retaining ring (Ref. No. 18). (Also see Figure 8.)

2. Gear Installation

- a. Replace the woodruff key (Ref. No. 7) into the drive shaft (Ref. No. 5) using soft-jaw pliers, or protect the shaft with rubber while pressing the key in place. Be sure that the key is level and that the key and shaft are free of burrs and scratches.
- b. The drive gear (Ref. No. 3) can be dropped in place and must be free to float on the shaft. Do not force the drive gear onto the shaft.

- c. The idler gear (Ref. No. 3) is placed on the idler shaft (Ref. No. 6) over the woodruff key and secured by the two external retaining rings (Ref. No. 4).
- d. Slide idler gear and shaft assembly into pump body (Ref. No. 9), rotating gear to get gears to mesh.
- e. Ensure that the gasket surfaces are clear of debris, and dry off surfaces.
Place new, clean and dry gasket (Ref. No. 2) on the pump body by sliding gasket over dowel pins. For bronze models, refer to Appendix 1 to identify the right thickness of gasket to use.

CAUTION *Any foreign material or liquid on the gasket or the gasket surfaces will increase the space between the gears and the cover, and substantially reduce pump performance.*

- f. Slide cover (Ref. No. 20) over dowel pins. Replace and tighten cover screws (Ref. No. 1). Alternate from top to bottom and side to side while tightening screws. Torque cover screws (See Appendix 1).
- g. Reinstall pump to motor and install safety shields and guards.
- h. All pumps must be primed before start-up and the seal chamber needs to be filled (See Figure 3).

PRESSURE RELIEF VALVE

DISASSEMBLY AND REASSEMBLY

1. Loosen lock nut (Ref. No. 29) on regulator/relief valve adjustment screw (Ref. No. 28) and rotate clockwise (CW) 1-2 turns to free regulator/relief valve spring retainer (Ref. No. 26).
2. Unscrew and remove adjustment screw (Ref. No. 28) by rotating counterclockwise (CCW).
3. Unscrew valve end cap (Ref. No. 27) by rotating counterclockwise (CCW).
4. Remove valve spring (Ref. No. 23) and valve piston (Ref. No. 22), cover and/or valve end cap.
5. Unscrew pipe plug (Ref. No. 30) by rotating counterclockwise (CCW).

Inspection of pressure relief valve components should include piston for wear and erosion, the spring and the o-rings for degradation. Components should be cleaned of accumulated build-up of solid matter. The pressure relief valve cover needs to be inspected for wear on the pressure relief valve piston seat (Ref. No. 21), the cover face and the bushing pockets. Replace any parts if worn.

To reassemble, reverse the disassembly steps above.

6. All pumps must be primed before start-up and the seal chamber needs to be filled (See Figure 3).

To order parts, contact a SHURflo Distributor or Order Direct.
Distributors can be found at www.shurfloindustrial.com.

Please provide following information:

- Model number
- Serial number (if any)
- Part description and number as shown in parts list

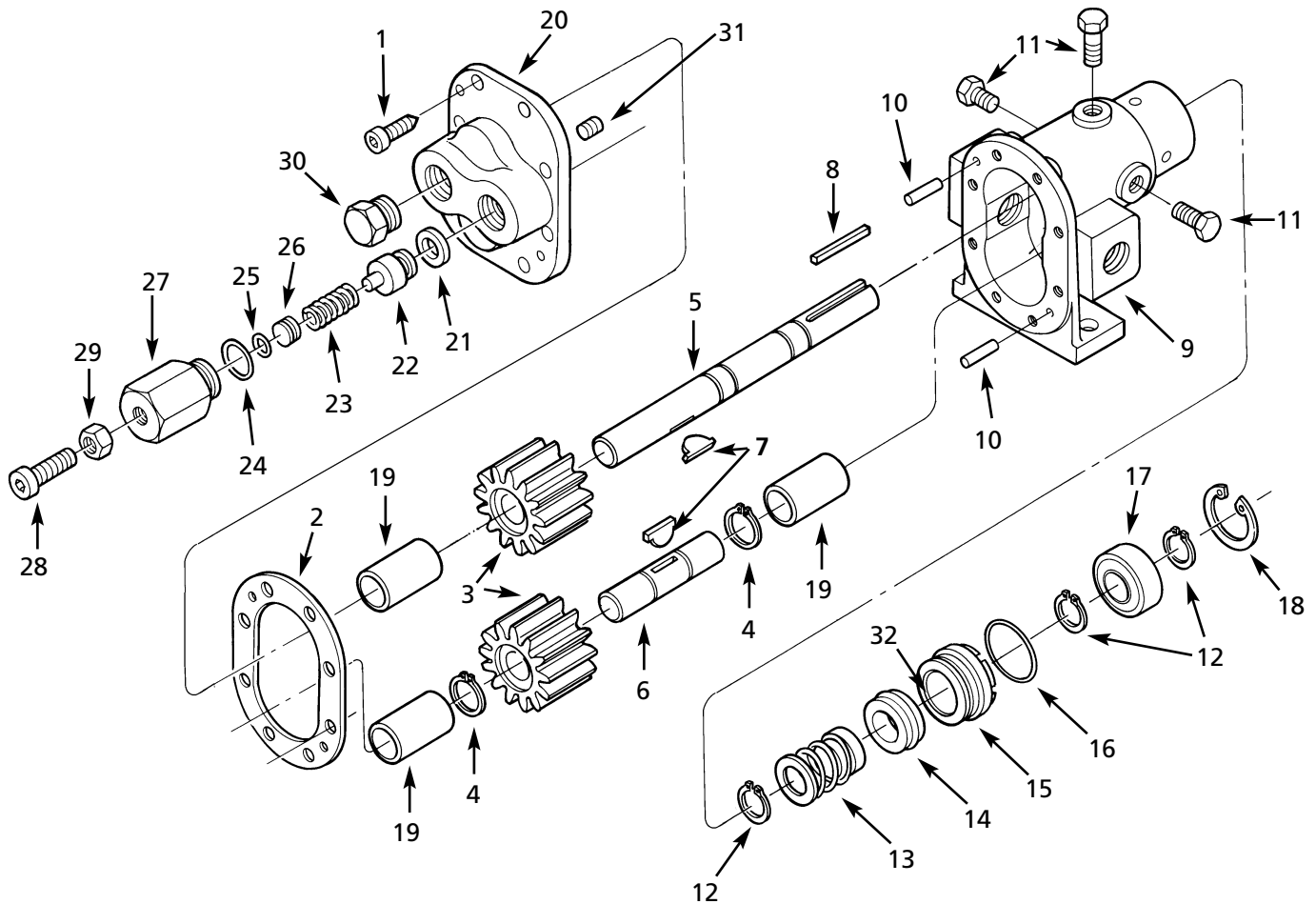

Figure 13 – Repair Parts Illustration

SHURflo Heavy-Duty Cast Iron and Bronze Pedestal Rotary External Gear Pumps

Repair Parts for Bronze Models

Ref. No.	Included In Kit	Description	Part No. For Bronze Model:					Qty.
			GPBN2V	GPBN3V	GPBN4V	GPBN5V	GPBN6V	
1		Soc. Hd. Cap Screw - SS (1 shown)	21916	21916	21916	22049	22049	8
2	1	Gasket - (Vellumoid) Std.	21642	21643	21643	22906	22906	1
Optional		High Temperature Gasket Kit	23952	23954	23954	23969	23969	
3	1	Gear - Ryton (PPS) Std.	13879	21137	12764	21136	13883	2
Optional		Gear - Steel	21456	21457	21458	21459	21460	
4	1	Ret. Ring (Ext.) - SS	21094	12840	12840	21063	21063	2
5	2	Drive Shaft - SS	21304	21306	21312	21338	21336	1
6		Idler Shaft - SS	21305	21307	21313	21337	21339	1
7	1	Key - SS	21301	12925	12841	12841	12841	2
8		Key - Square - Steel	21436	21437	21437	21437	21437	1
9		Body - Bronze	21212	21213	21214	21225	21227	1
10		Dwl. Pin - SS	22350	22350	22350	22350	22350	2
11		Seal & Prime Flush Plug - Brass	00336	00336	00336	00336	00336	3
12	2	Ret. Ring (Ext.)	04304	04258	04258	15952	15952	3
*13/14	2	Mech Seal/Seal Seat (Buna) Std.	24604S	24605S	24605S	24606S	24606S	1
Optional		Mech Seal/Seal Seat (Viton)	24608S	24609S	24609S	24610S	24610S	
**Optional		Mech Seal/Seal Seat (Teflon)	24612S	24613S	24613S	24614S	24614S	
15	2	Seat Retainer	21407	21909	21909	21431	21431	1
16		O-Ring (Buna) Std.	21303	21913	21913	21428	21428	1
Optional		O-Ring (Viton)	22173	22174	22174	24740	24740	
Optional		O-Ring (Teflon)	22191	22192	22192	24741	24741	
17	2	Bearing - Steel	04306	04257	04257	19988	19988	1
18		Ret. Ring (Int.) - Steel	04303	04259	04259	19942	19942	1
19		Bushing - Carbon Graphite	21332	21333	21333	21314	21314	3
20		Relief Valve Cover - Bronze (Std.)	21289	21290	21290	21291	21291	1
†Optional		Non-Relief Valve Cover - Bronze	21233S	21248S	21248S	21257S	21257S	
Relief Valve Components								
21	3,4,5	R.V. Seat - SS	Kit	Kit	Kit	Kit	Kit	1
22	3,4,5	Piston - 303 SS	Kit	Kit	Kit	Kit	Kit	1
23	3,4,5	Spring - 17-7 SS	Kit	Kit	Kit	Kit	Kit	1
24	3	O-Ring (Buna) Std.	Kit	Kit	Kit	Kit	Kit	1
Optional	4	O-Ring (Viton)	Kit	Kit	Kit	Kit	Kit	
Optional	5	O-Ring (Teflon)	Kit	Kit	Kit	Kit	Kit	
25	3	O-Ring (Buna) Std.	Kit	Kit	Kit	Kit	Kit	1
Optional	4	O-Ring (Viton)	Kit	Kit	Kit	Kit	Kit	
Optional	5	O-Ring (Teflon)	Kit	Kit	Kit	Kit	Kit	
26		Retainer - SS	21558	21558	21558	21563	21563	1
27		Cap - Brass	21555	21555	21555	21562	21562	1
28		Pressure Relief Valve Adj. Screw - 18-8 SS	21710	21710	21710	21710	21710	1
29		Lock Nut - SS	21711	21711	21711	21711	21711	1
30		Plug Internal Relief Plug - Brass	21705	21706	21706	21707	21707	1
***31		External Bypass Relief Plug - SS	21708	21709	21709	22349	22349	1
**32		Teflon Seal Anti-Rotation Pin	22537	22537	22537	22537	22537	1
2, 3, 4, 7		Kit 1 - Gear Repair Kit	22267	22268	22269	22270	22271	
5,12,13/14,15,17		Kit 2 - Shaft Assy. Kit (Buna)	22249	22250	22251	22252	22253	
21, 22, 23, 24, 25		Kit 3 - Relief Valve Assy. Kit (Buna)	22281	22281	22281	22282	22282	
21, 22, 23, 24, 25		Kit 4 - Relief Valve Assy. Kit (Viton)	24704	24704	24704	24707	24707	
21, 22, 23, 24, 25		Kit 5 - Relief Valve Assy. Kit (Teflon)	24793	24793	24793	24794	24794	

NOTE: (*) Mech. seal and seat sold as set only (Ref. Nos. 13 & 14) - carbon ceramic faces with 18-8 SS components.

(**) When ordering the optional Teflon seal, Teflon Seal Anti-Rotation Pin is required (Ref. No. 32).

(***) Not installed at factory - part comes loose in box.

(†) Includes Bushings (Ref. No. 19).

When converting to a different seal/seat material, remember to order the o-rings (Ref. Nos. 16, 24 & 25) of the same material.

SS = Stainless Steel Ryton = PPS (Polyphenylene Sulfide)

Kits do not ship with gaskets.

Bronze Models GPBN2V thru GPBN6V Cast Iron Models GPCV2V thru GPCV6V

Repair Parts for Cast Iron Models

Ref. No.	Included In Kit	Description	Part No. For Cast Iron Model:					Qty.
			GPCV2V	GPCV3V	GPCV4V	GPCV5V	GPCV6V	
1		Soc. Hd. Cap Screw - SS (1 shown)	21916	21916	21916	22049	22049	8
2	1	Gasket (Vellumoid) Std.	21642	21643	21643	22906	22906	1
Optional 3	1	High Temperature Gasket Kit	23952	23954	23954	23969	23969	
Optional 4	1	Gear - (Steel) Std.	21456	21457	21458	21459	21460	2
Optional 5	1	Gears - Ryton (PPS)	13879	21137	12764	21136	13883	
Optional 6	1	Gear Ret. Ring (Ext.)	21094	12840	12840	21063	21063	2
7	2	Drive Shaft - Steel	21446	21448	21450	21452	21454	1
8	2	Idler Shaft - Steel	21447	21449	21451	21453	21455	1
9	1	Key - Steel	21301	11515	12622	12622	12622	2
10	1	Key - Square	21436	21437	21437	21437	21437	1
11		Body	21216	21217	21218	21226	21228	1
12		Dwl. Pin	22350	22350	22350	22350	22350	2
13		Seal & Prime Flush Plug-Steel	21409	23182	23182	23182	23182	3
14	2	Ret. Ring (Ext.) - SS	05484	05328	05328	15952	15952	3
*13/14	2	Mech Seal/Seal Seat (Viton) Std.	24608S	24609S	24609S	24610S	24610S	1
Optional		Mech Seal/Seal Seat (Buna)	24604S	24605S	24605S	24606S	24606S	
**Optional		Mech Seal/Seal Seat (Teflon)	24612S	24613S	24613S	24614S	24614S	
15	2	Seat Retainer	21863	21864	21864	21865	21865	1
16		O-Ring (Viton) Std.	22173	22174	22174	24740	24740	1
Optional		O-Ring (Buna)	21303	21913	21913	21428	21428	
Optional		O-Ring (Teflon)	22191	22192	22192	24741	24741	
17	2	Bearing - Steel	04306	04257	04257	19988	19988	1
18		Ret. Ring (Int.) - Steel	04303	04259	04259	19942	19942	1
19		Bushing - Cast Iron	†	†	†	†	†	-
20		Relief Valve Cover - Cast Iron (Std.)	21292	21293	21293	21294	21294	1
Optional		Non-Relief Valve Cover - Cast Iron	21234	21249	21249	21258	21258	
Relief Valve Components								
21		R.V. Seat - Steel	†	†	†	†	†	
22	3,4,5	Piston - 303 SS	Kit	Kit	Kit	Kit	Kit	1
23	3,4,5	Spring -17-7 SS	Kit	Kit	Kit	Kit	Kit	1
24	4	O-Ring (Viton) Std.	Kit	Kit	Kit	Kit	Kit	1
Optional	3	O-Ring (Buna)	Kit	Kit	Kit	Kit	Kit	
Optional	5	O-Ring (Teflon)	Kit	Kit	Kit	Kit	Kit	
25	4	O-Ring (Viton) Std.	Kit	Kit	Kit	Kit	Kit	1
Optional	3	O-Ring (Buna)	Kit	Kit	Kit	Kit	Kit	
Optional	5	O-Ring (Teflon)	Kit	Kit	Kit	Kit	Kit	
26		Retainer - SS	21422	21422	21422	21435	21435	1
27		Cap - Steel	21421	21421	21421	21434	21434	1
28		Pressure Relief Valve Adj. Screw - 18-8 SS	21710	21710	21710	21710	21710	1
29		Lock Nut - SS	21711	21711	21711	21711	21711	1
30		Plug - Steel	21409	21419	21419	21433	21433	1
***31		Set Screw - SS	21708	21709	21709	22349	22349	1
**32		Teflon Seal Anti-Rotation Pin	22537	22537	22537	22537	22537	1
2, 3, 4, 7		Kit 1 - Gear Repair Kit	22272	22273	22274	22275	22277	
5, 12, 13/14, 15, 17		Kit 2 - Shaft Assy. Kit (Viton)	22254	22255	22256	22257	22258	
22, 23, 24, 25		Kit 3 - Relief Valve Assy. Kit (Buna)	22281	22281	22281	22282	22282	
22, 23, 24, 25		Kit 4 - Relief Valve Assy. Kit (Viton)	24709	24709	24709	24712	24712	
22, 23, 24, 25		Kit 5 - Relief Valve Assy. Kit (Teflon)	24795	24795	24795	24796	24796	

(†) Not standard in cast iron pumps – not required or needed.

NOTE: (*) Mech. seal and seat sold as set only (Ref. Nos. 13 & 14) - carbon ceramic faces with 18-8 SS components.

(**) When ordering the optional Teflon seal, Teflon Seal Anti-Rotation Pin is required (Ref. No. 32).

(***) Not installed at factory - part comes loose in box.

When converting to a different seal/seat material, remember to order the o-rings (Ref. Nos. 16, 24 & 25) of the same material.

SS = Stainless Steel Ryton = PPS (Polyphenylene Sulfide)

Kits do not ship with gaskets.

Appendix 1 - Gear Pump Gasket Adjustment for Temperature (Bronze Models only)

Gear pump is factory assembled to operate within a temperature range of 70° – 120° F (20° – 50° C). For temperatures outside this range, please see the table below for your series and port size pump.

NOTE: Always refer to the original owner's manual repair and maintenance sections on pump disassembly and assembly for more detailed instructions.

NOTE: When pumping fluids of high viscosity (>500 SSU), the required torque and HP can be reduced by adding a gasket for increased gear clearance.

Gasket Installation Instructions (refer to assembly diagram below):

1. Turn off power to pump, turn off inlet and outlet valves, and relieve pressure in lines.
2. Allow pump to cool.

3. Remove cover screws (1), cover (2) and gasket (3). Be sure to mark proper orientation of cover and pump body.
4. Replace gaskets (3) per instructions listed in table.
5. Replace cover (2) and cover screws (1) according to orientation marked in step 3.
6. Tighten cover screws (1) in sequence listed on diagram. Use torque specifications listed in table.

Kit PN	NPT Port Size	Temp Range	Instructions	Bolt Torque	
Bronze Gear Pump Series	23952	Pumps with 3/8" ports	Up to 120° F (50° C)	Use standard vellumoid/paper gasket as shipped (0.006" thick)*	23 in.-lbs. (2.6 N-m)
			120° F – 210° F (50° C – 99° C)	Use optional thicker (0.015") vellumoid/paper gasket	
	23954	Pumps with 1/2" and 3/4" ports	Up to 120° F (50° C)	Use standard vellumoid/paper gasket as shipped (0.006" thick)*	23 in.-lbs. (2.6 N-m)
				120° F – 210° F (50° C – 99° C)	
	23969	Pumps with 1" and 1¼" ports	Up to 70° F (20° C)	Use optional thinner (0.006") vellumoid/paper gasket	75 in.-lbs. (8.5 N-m)
			70° F – 120° F (20° C – 50° C)	Use standard vellumoid/paper gasket as shipped (0.010" thick)*	
120° F – 210° F (50° C – 99° C)			Use 2X optional thinner (for a total of 0.012") vellumoid/paper gasket		

***Standard Set-up**

