

# HYDROMATIC® HBB-SKV50 1/2 HP BASIN BOSS™ PACKAGED SEWAGE SYSTEM

## 24" x 24" Basin

30% more capacity than standard 18" x 30" basins.

## Fully Assembled

Pump is pre-installed in basin, with integral torque stops to ensure stability.

## Anti-Flotation Features

Include concrete splash lip and unique basin shape to keep the system from floating or becoming "un-installed".

## Integral 360° Top Grip

For easy lifting and handling in tight spaces.

## Stackable Design

Allows for compact inventory.

## Concrete-Proof Cover Insert

Protects the system from damage during rough-in and masonry work.

## Easy-Out™ Rod

Allows removal of float switch without disassembling basin lid, or handling pump or plumbing. Additional clip for secondary float included; float sold separately.

## Available with Q-Alert™

### High-Water Alarm

Small, residential high-water alarm is ideal for furnishing an inexpensive way to protect home and valuables. Indoor/outdoor applications, sold separately.



| Catalog Number   | HP  | Package Type | Cord Length | Switch Type             | Basin Size | Includes Alarm |
|------------------|-----|--------------|-------------|-------------------------|------------|----------------|
| HBB-SKV50        | 1/2 | Preassembled | 10'         | Wide-angle float switch | 24" x 24"  | No             |
| HBB-SKV50-QAlert | 1/2 | Preassembled | 10'         | Wide-angle float switch | 24" x 24"  | Yes            |

# HYDROMATIC® HP33/HP50 CAST IRON SUBMERSIBLE SUMP PUMP

## Pump Characteristics

| Pump/Motor Unit  | Submersible                               |     |
|------------------|---|-----|
| Automatic Models | SKV50A1                                   | -   |
| Horsepower       | 1/2                                       |     |
| Full Load Amps   | 12.0                                      | 6.0 |
| Motor Type       | Split Phase                               |     |
| RPM              | 1750                                      |     |
| Phase Ø          | 1   |     |
| Voltage          | 115                                       | 230 |
| Hertz            | 60  |     |
| Operation        | Intermittent                              |     |
| Temperature      | 140°F Ambient                             |     |
| NEMA Design      | L   |     |
| Insulation       | Class B                                   |     |
| Discharge Size   | 2" NPT std. (3" opt.)                     |     |
| Solids Handling  | 2"  |     |
| Unit Weight      | 54 lbs.                                   |     |
| Power Cord       | 16/3, SJTW, 115V = 10' std.<br>(20' opt.) |     |

## Specifications

### Pump

- Housing – Class 30 cast iron
- Impeller – Thermoplastic recessed
- Maximum Limits – Intermittent liquid temperature: 140°F (60°C)
- Electrical – 115V, 1Ø, 12.0 FLA, 60 Hz  
230V, 1Ø, 6.0 FLA, 60 Hz
- Motor – 1/2 HP split phase w/thermal overload protection, 1750 RPM

### Basin

- Construction – Structural foam;  
24" x 24"; 45-gallon capacity

## Performance Data

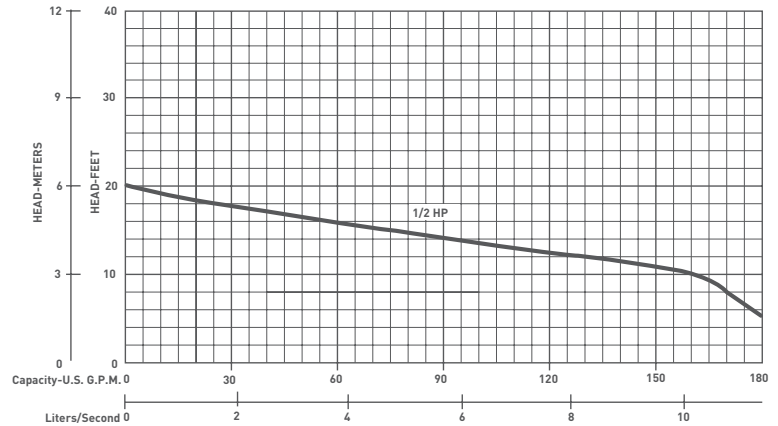

## Dimensional Data

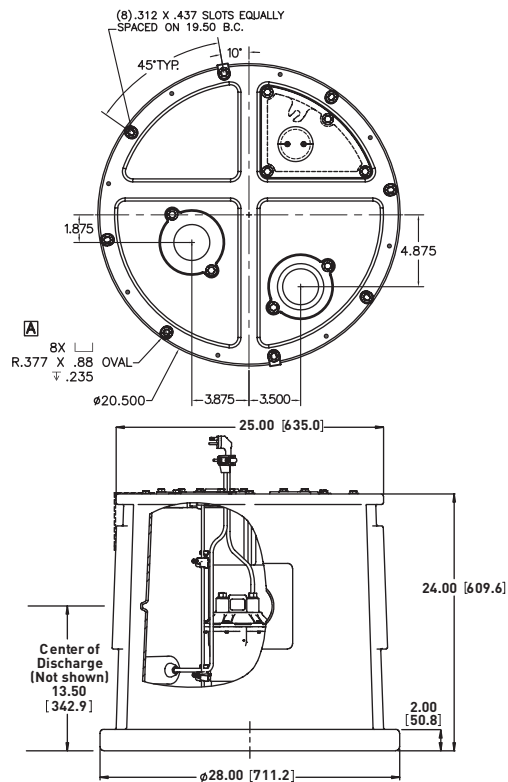

Pump may differ from what is shown in drawing. All dimensions (in inches) are for estimating purposes only. Metric for international use. Component dimensions may vary ± 1/8 inch. Dimensions and weights are approximate. On/off level adjustable.



USA  
293 WRIGHT STREET, DELAVAN, WI 53115 WWW.HYDROMATIC.COM  
PH: 888-957-8677 ORDERS FAX: 800-426-9446

CANADA  
269 TRILLIUM DRIVE, KITCHENER, ONTARIO, CANADA N2G 4W5  
PH: 519-896-2163 ORDERS FAX: 519-896-6337

Because we are continuously improving our products and services, Pentair reserves the right to change specifications without prior notice.