

PARTS LIST

ITEM	PART NO.	DESCRIPTION	REQ'D
1	12327	PULLEY ASSY	1
2	12622	NON-ROK-KEY	1
3	12368	SPACER	1
4	4259	RET. RING	2
5	4288	RET. RING	2
6	12857	CAP SCREW	3
7	12710	LOCKWASHER	3
8	12503	HOUSING	1
9	12231	"O" RING GASKET	1
10	10515	SCREW	1
11	10627	CAM (182)	1
12	4432	DRIVE KEY	1
13	12367	SHAFT	1
14	9959	IMPELLER	1
15	4264	THRUST WASHER	1
16	12856	END PLATE	1
17	12855	GASKET	1
18	12328	BODY	1
19	12256	SEAL SEAT	1
20	12314	MECH. SEAL	1
21	1221	BALL BEARING	2
22	5133	SPACER BEARING	1
23	11541	PIN	1
24	12305	RET. RING	1
25	13285	TAG	1

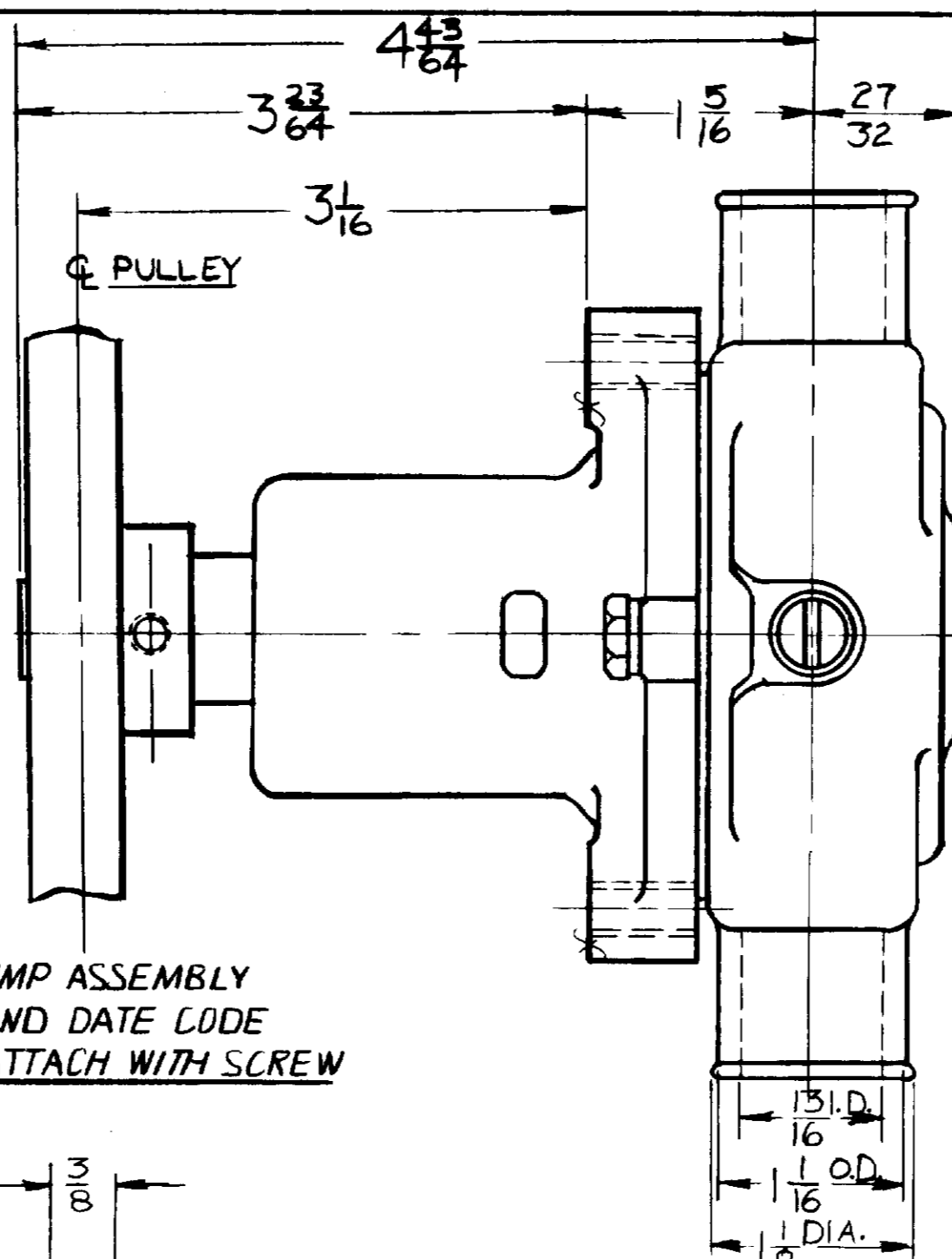

SERVICE ASSY NO.	COMPONENT ITEM NO'S
① SEAL & SEAT ASSY NO. 12859	19 & 20
MAJOR KIT NO 12400	
MINOR KIT NO 12399	

G-20

UNIT PACKAGING:
 No 17636 CARTON W 1 REQ'D
 12209 LABEL 1 REQ'D

STAMP PUMP ASSEMBLY
 No G-20 AND DATE CODE
 ON TAG ATTACH WITH SCREW

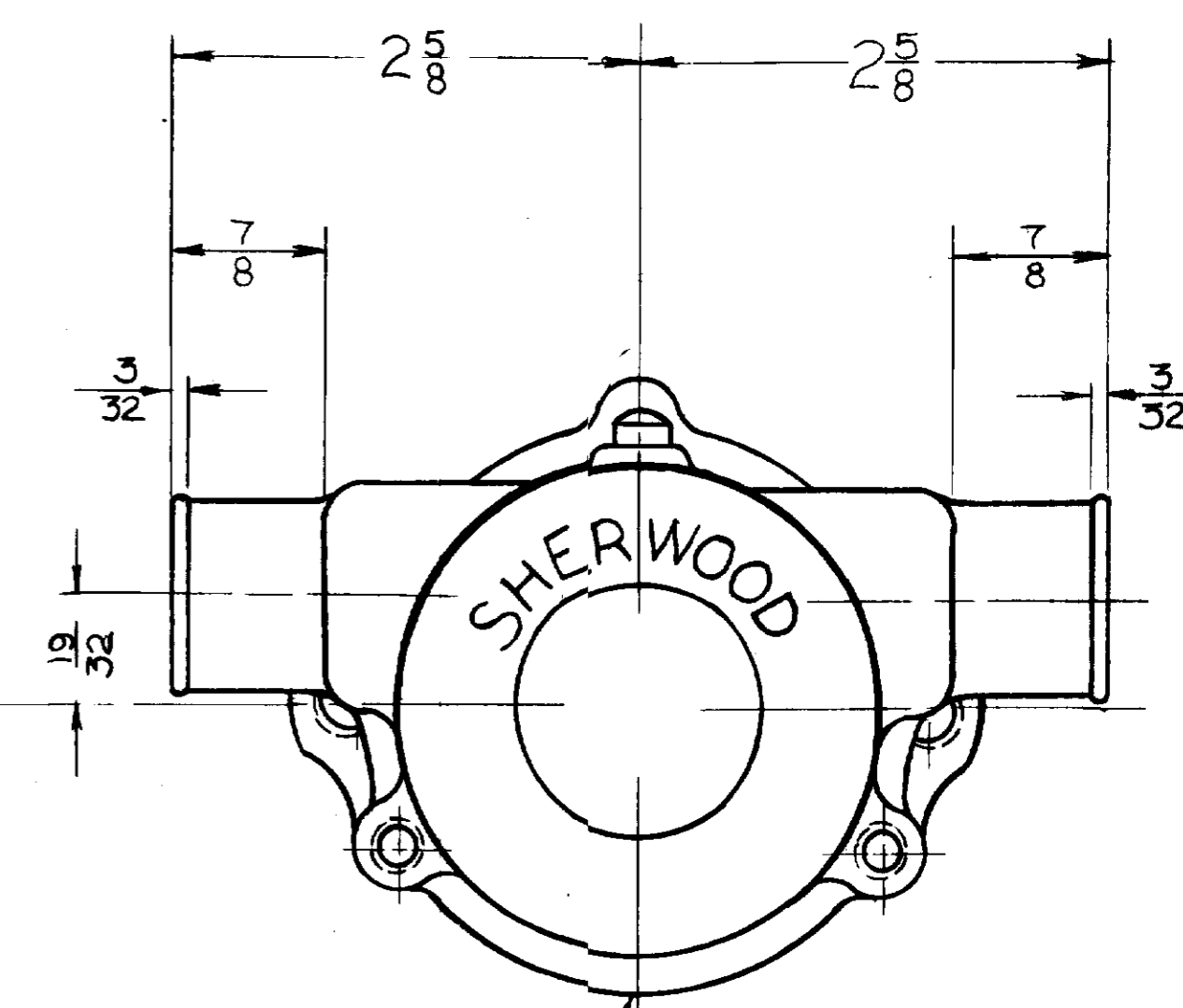
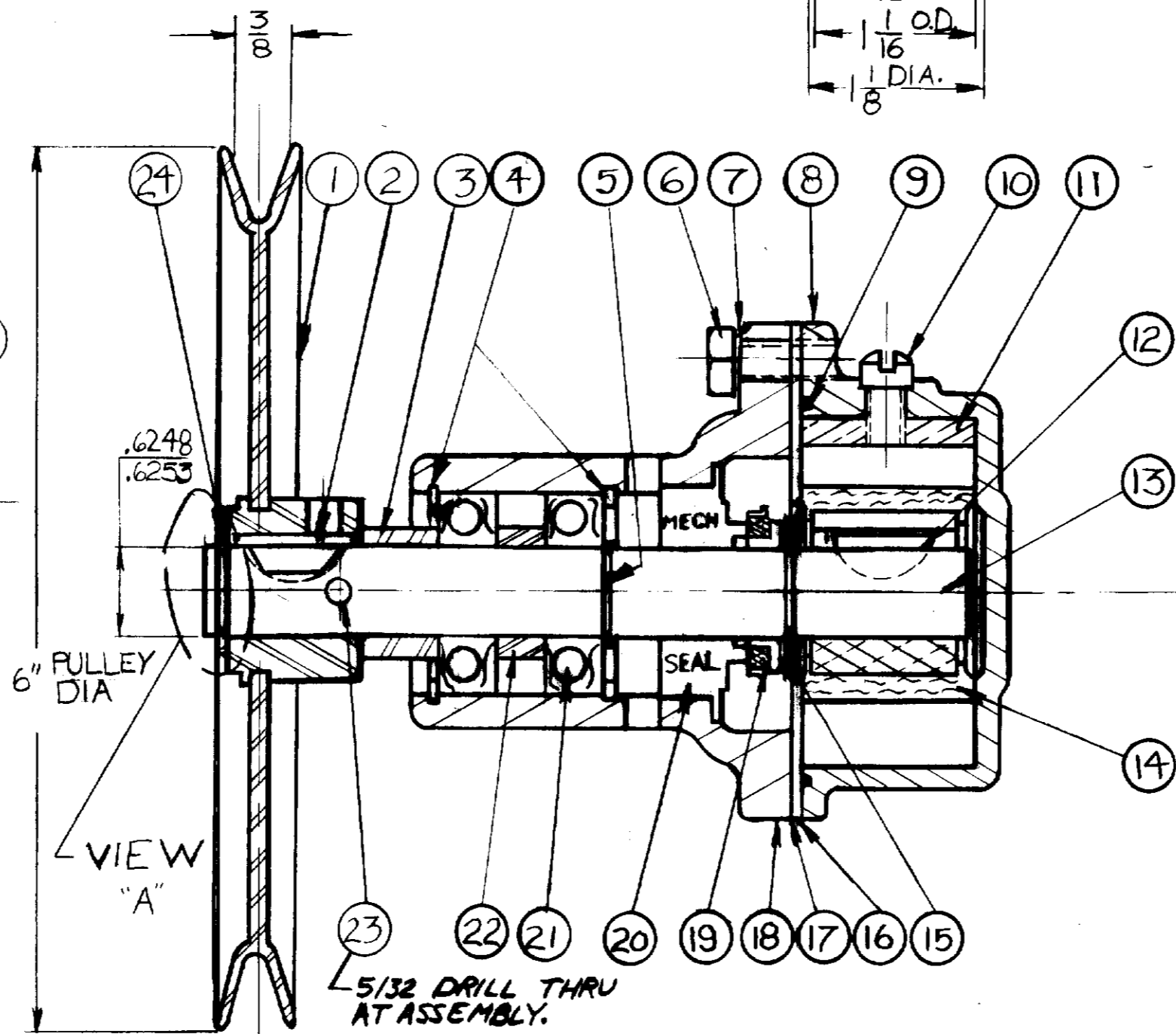
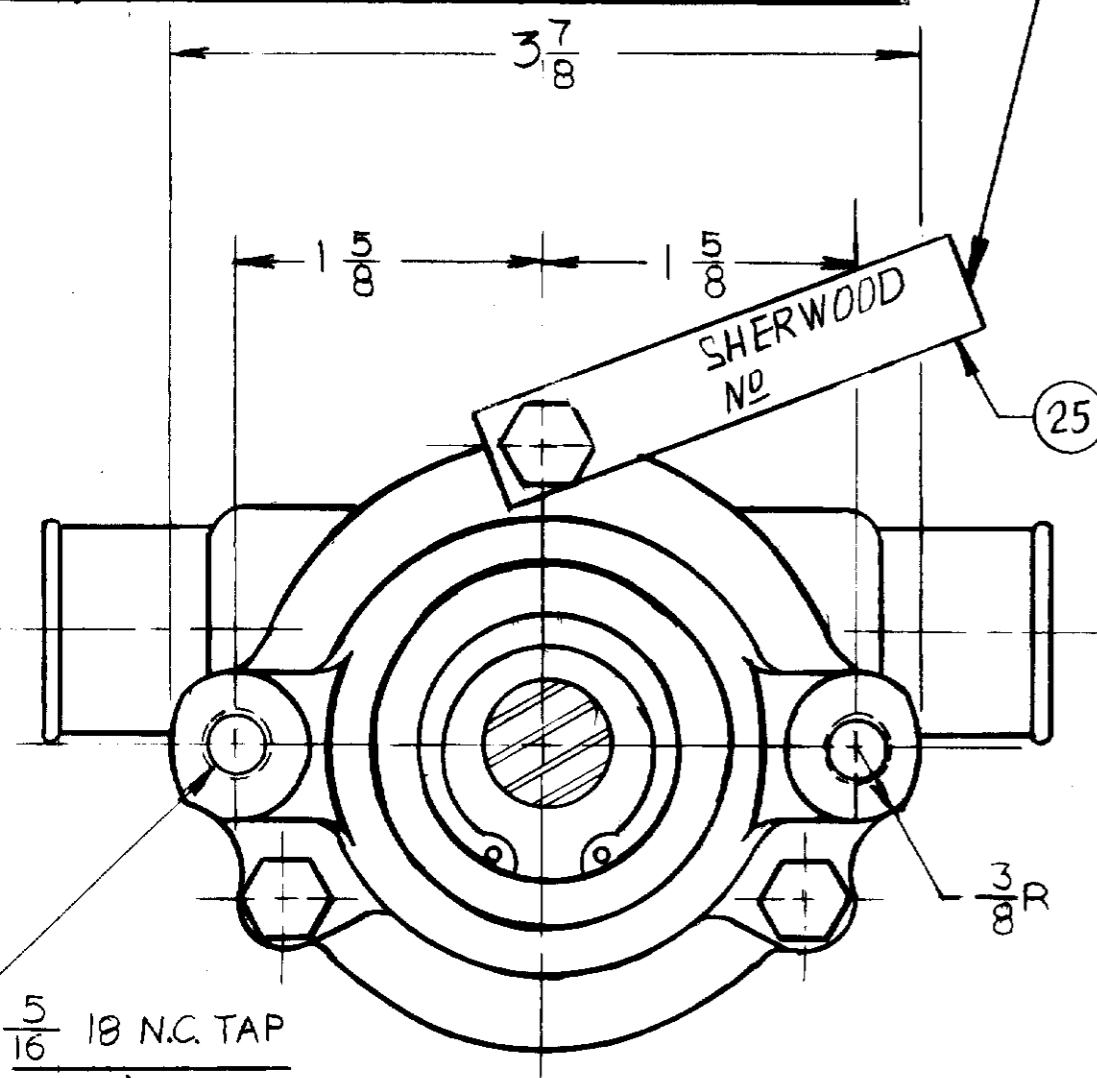

STAMP PART NO &
 DATE CODE HERE

REF R-057007

FLOW CURVE 72010R-72011R

VIEW "A"
 ASSEMBLE RETAINING RING AS SHOWN
 THIS SIDE TOWARDS PULLEY HUB
 LOCATE RETAINING RING AS SHOWN
 IN RELATION TO THE KEY WAY

REV.	DESCRIPTION	CKR	DATE
T	12859 WAS 12322	SH	7/5/90
S	TAG 13285 ADDED	SH	10-27-88
R	REDRAWN WITHOUT CHANGES	RM	5-14-79

UNLESS OTHERWISE SPECIFIED
 TOLERANCE TO BE
 CAST DIMENSION ± .020
 MACHINED DIMENSION
 FRACTIONAL ± .010
 DECIMAL ± .005
 ANGLES ± 1.2'
 MACHINED SURFACE ROUGHNESS
 ALLOW 1.16 STOCK ON ALL FINISHED
 SURFACES FOR MACHINING
 BREAK ALL SHARP EDGES .010 MAX
 CAST FILLETS AND RADII 1/16 R

SHERWOOD
 A DIVISION OF HYPRO CORPORATION
 301 E. WATSON AVE. - DETROIT, MICHIGAN 48227

DRGTS MAN	DATE	CHECKER	DATE	ASSY NO
R.I.	5-11-79	R.B.M.	5-14-79	

TITLE: PUMP ASSEMBLY RUBBER IMPELLER
 MATERIAL: SEE DETAILS
 G 20

PROJ. No 187