

MODEL 374B
(OPTIONAL POSITION 3 SHOWN)

AURORA[®] 370 SERIES TWO STAGE END SUCTION PUMPS

AURORA® 370 SERIES

Two Stage End Suction Pumps

Capacities to 310 G.P.M.
Heads to 790 Ft.
Temperatures to 300°F

Reliable Operation.

Compact system designs, application trends requiring increased pressures and temperatures and the much higher costs of engineering and construction have brought about a demand for a practical multistage frame mounted end suction pump. Various pressures and forces generated within a multi-stage unit must balance making shaft and bearing design more critical than in single stage units. Split case pump designs readily solve the mechanical problems of multistaging, but are costly. Aurora Pump, a leader in the pump industry, has combined over 90 years of knowledge in multistage split case and end suction design and manufacturing techniques to produce a unique combination of technical features in the 370 Series. Significantly, this new Aurora pump design offers:

- Low NPSH Requirements
- Compact Design for Easy Installation and Maintenance
- Quiet, Smooth-Running Design for Longer Life

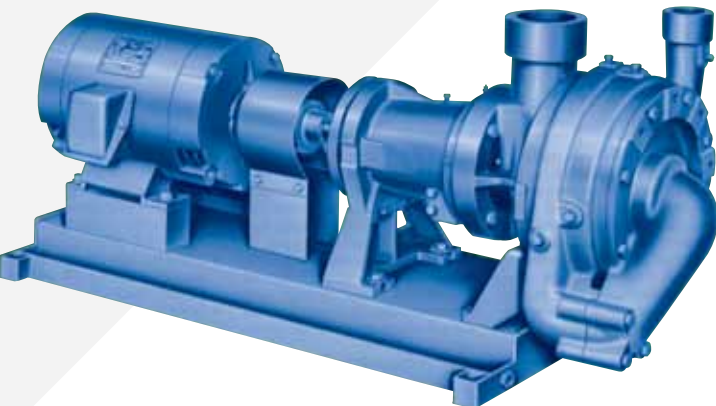

Standard Features

- Iron fitted construction
- Bronze shaft sleeves
- Dynamically balanced cast iron shell core enclosed impellers
- Bronze case wearing rings
- Regreasable bearings
- Discharge position No. 1
- Hydrostatic test
- Carbon steel shaft
- 303 stainless high temperature mechanical seal
- O-ring sealed shaft sleeve
- Coupling guard

Optional Features

- All iron construction
- 316 stainless steel shaft sleeves
- Stainless steel shaft or sleeve
- Cast iron case wearing rings
- Oil lubricated ball bearings
- Alternate piping positions
- Steel drip-rim bases
- 316 stainless, special high temperature mechanical seal with tungsten carbide and carbon parts

Pump Features

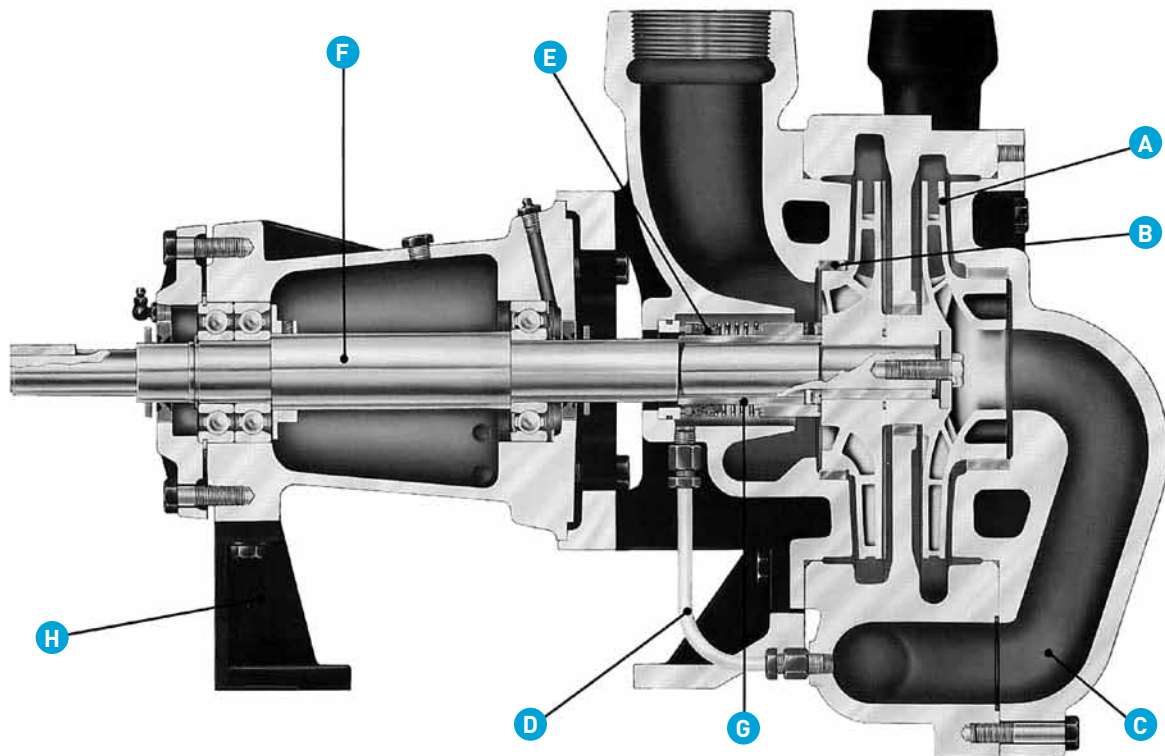

A. Dynamically Balanced Impellers

keyed to the shaft and secured by a capscrew and washer. Quality controlled manufacturing process assures consistently high performance. Enclosed design provides highest efficiency, low NPSH and minimum wear for long service life. After developing pressure in the first stage impeller the liquid is directed to a second stage impeller where the process is repeated, doubling the discharge head. By offsetting the discharges by 180° the radial loads on the bearing are balanced and shaft deflection is minimized.

B. Case Wearing Rings

prevent wear on casing and are easily and inexpensively replaced.

C. Hydrostatic Test

guarantees casting and seal integrity.

D. Relief Line

assures adequate venting of the seal chamber and lube of the seal faces.

E. High Temperature Mechanical Seal

is standard and located on the first stage to eliminate the need for costly high pressure seal and premature failure.

F. Carbon Steel Shaft

is designed for minimum deflection, not to exceed .002" at the sealing faces at maximum load. Bearings selected for 2 years minimum life at maximum load. Average bearing life is 10 years. Grease lubrication is standard.

G. Bronze Shaft Sleeve

prevents shaft wear and extends the entire length of the seal box. The sleeve is slip fit over the shaft and is keylocked. Shaft sleeve and impeller screw are sealed by O-ring gaskets to eliminate corrosion of the shaft by the pumped liquid. This eliminates the requirements for high cost, stainless steel shafts.

H. Rear Support Foot

provides power frame support and simplifies coupling alignment.

Dimension Details

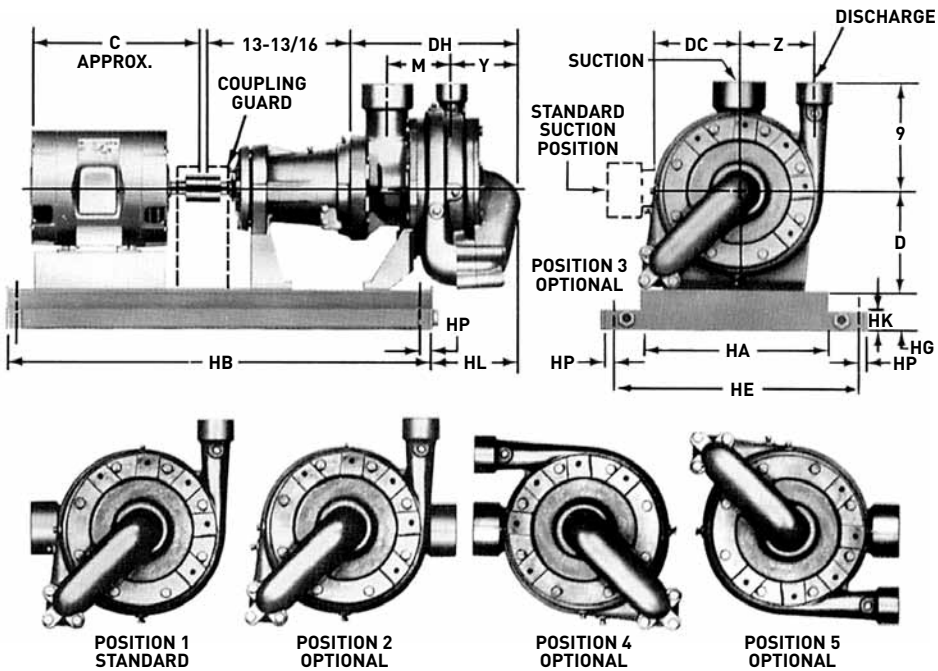

Notes:

1. Dimensions and weights are approximate.
2. All dimensions are in inches and may vary $\pm 1/4"$.
3. Frame sizes, "C" dimension and motor weight are for open drip-proof motors only.
4. Conduit box is shown in approximate position. Dimensions are not specified as they vary with each motor manufacturer.
5. Add pump, base and motor weight for unit weight.
6. Not for construction purposes unless certified.
7. Discharge position No. 1 is furnished as standard unless otherwise specified.
8. Aurora® Pump reserves the right to make revisions to its products and their specifications, and to this brochure and related information without notice.
9. Power frame selection can be made from the range charts.

Pump Size	Pump Weight
1-1/2 x 3 x 10	215 lbs.
2 x 4 x 10	325 lbs.

Pump Size			D	DC	DH	HL	M	Y	Z
Discharge	Suction	Case Bore							
1-1/2	3	10	8	7	14-1/2	8	5-3/4	5-13/16	6-1/8
2	4	10	9	7-5/8	15-11/16	9-3/16	6-3/4	6-9/16	6-9/16

Pump Model	Base Number	Weight Lbs.	HA	HB	HE	HG	HP	HK	Power Frame Weight (Lbs.)	
									2	3
374	5	56	11	36-1/2	15-7/8	3	11/16	1-1/2	82	87
	6	68	11	42-1/2	15-7/8	3	11/16	1-1/2		
	8	96	14	42-1/2	19	3	11/16	1-1/2		
	9	110	14	48-1/2	19	3	3/4	1-1/2		
	11	164	18	46-1/2	25-1/8	4	13/16	2		
	12	192	18	54-1/2	25-1/8	4	13/16	2		

Motor Frame	Horsepower		Motor Weight in Lbs.	C	Base Number
	3500 RPM	1750 RPM			
143T	-	1	30	12	5
145T	-	1-1/2-2	35	13	5
182T	-	3	45	13	5
184T	-	5	50	14	5
213T	10	7-1/2	120	16	5
215T	15	10	144	18	6
254T	20	15	217	21	8
256T	25	-	246	23	9
284TS	30	-	320	22	9
286TS	40	-	351	24	9
324TS	50	-	442	25	11
326TS	60	-	522	26	11
364TS	75	-	540	27	11
365TS	100	-	590	28	12

Range Chart

Individual performance curves should be checked for final selection. For selections not shown on this chart, please refer to the factory.

3500 RPM 1750 RPM Power Frames No. 2 and 3

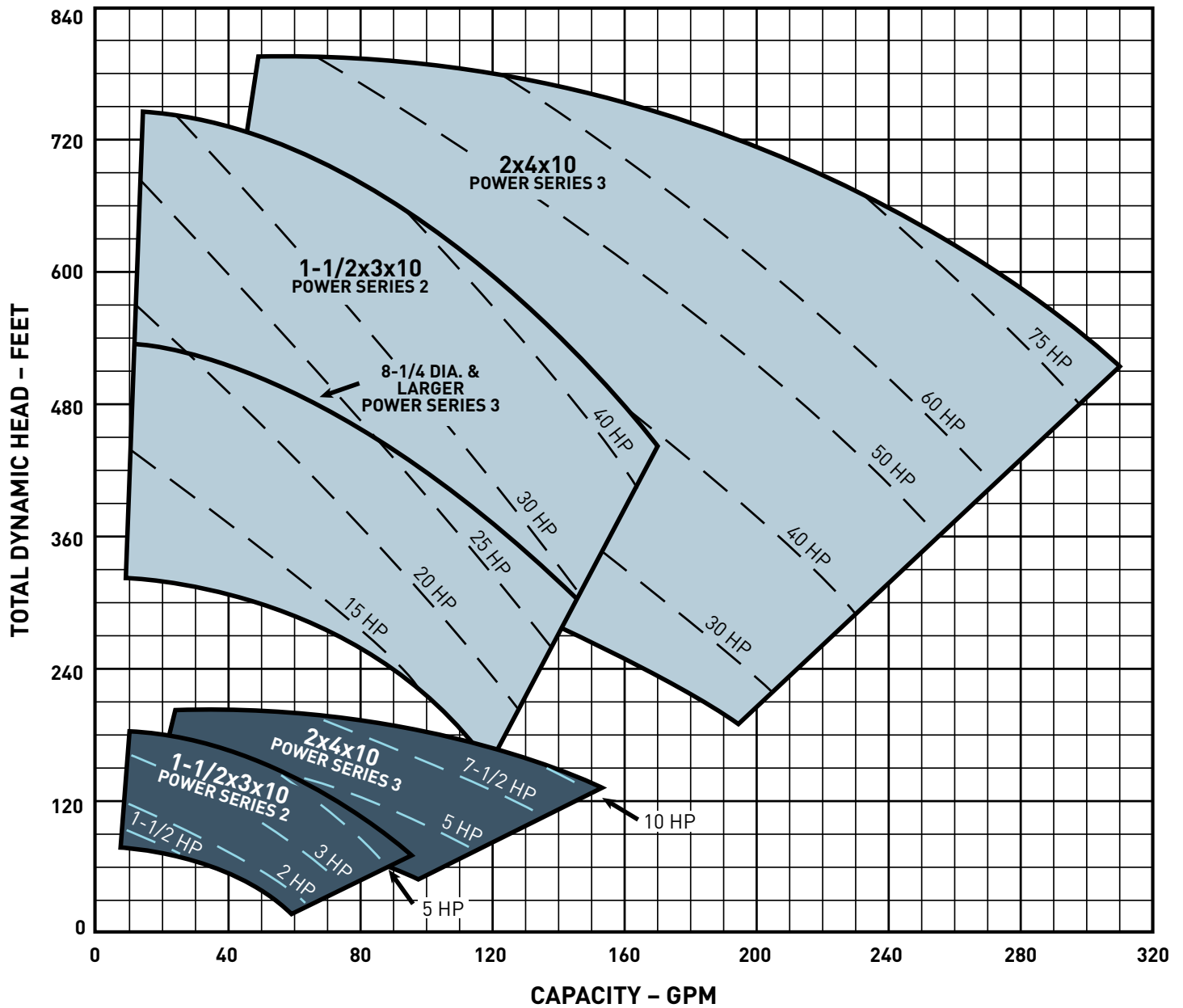

Engineering Specifications

Design Details

Area	Description	Power Series	
		2	3
Pump Shaft	Rotation from Driver End	CW	CW
	Diameter at Impeller	1-1/4	1-1/2
	Diameter at Shaft Sleeve	1-3/8	1-1/2
	Diameter between Bearings	1-15/16	2-3/8
	Diameter at Coupling End	1-1/8	1-3/8
	Coupling Key – Square	1/4	3/8
	Maximum Deflection at Seal Face	.002	.002
	Outside Diameter of Sleeve	1-3/4	1-3/4
Ball Bearing	Bearing (Inb. Radial)	308	310
	Bearing (Matched Set)		
	Conrad	308	310
	Angular Contact	7308	7310
	Bearing Centers	7-11/16	7-11/16
	Minimum B ₁₀ Bearing Life under Maximum Load	2 yrs.	2 yrs.

Outboard Tandem Thrust Bearing

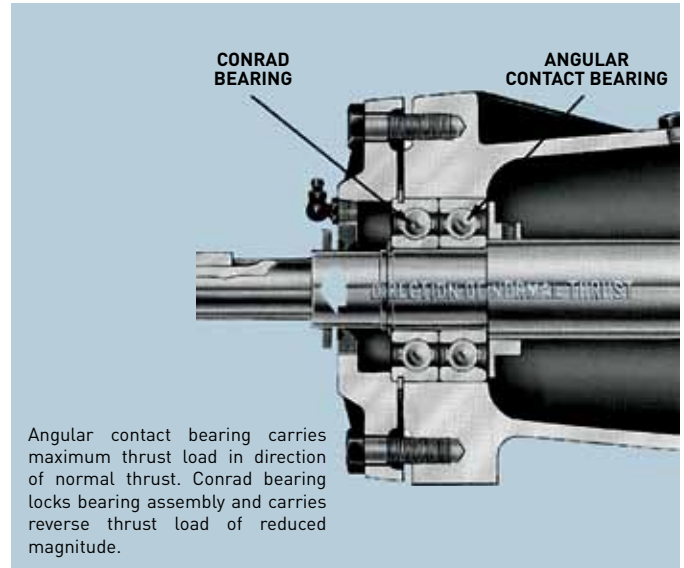

Limitations

Maximum Limitations Based on Standard Materials and Pumping Clear Water		
Speed – RPM	Model 374	3600
HP	1-1/2 x 3 x 10	60
	2 x 4 x 10	100
Hydrostatic Test Pressure psi		600
Case Working Pressure psi	-20° to 150° F	400
	200° F	370
	225° F	355
	250° F	340
	275° F	325
	300° F	310
Suction Pressure psi		100
Temperature ° F	Sealing Method	Frame Mounted
	Standard High Temperature Mechanical Seal	225
	Special High Temperature Mechanical Seal	300

Materials of Construction

Pump Part	Iron Fitted	All Iron
Bracket	Cast Iron ASTM A48	Cast Iron ASTM A48
Casing	Cast Iron ASTM A48	Cast Iron ASTM A48
Impellers	Cast Iron ASTM A48	Cast Iron ASTM A48
Cover	Cast Iron ASTM A48	Cast Iron ASTM A48
Mechanical Seal	303 Stainless Steel Metal Parts Buna-N Elastomer Parts Ceramic Seat and Carbon Washer	
Power Frame	Cast Iron ASTM A48	Cast Iron ASTM A48
Shaft	Steel AISI C1045	Steel AISI C1045
Sleeves	Bronze ASTM B62	Stainless Steel AISI 316
Wearing Rings	Bronze ASTM B62	Cast Iron ASTM A48

Engineering Specifications

Two Stage End Suction Pumps

The contractor shall furnish (and install as shown on the plans) Aurora® Model (374 horizontal flexible coupled) centrifugal pump sizes 1-1/2 x 3 x 10 or 2 x 4 x 10 (iron fitted) (all iron) construction. Each pump shall have a capacity of _____ GPM at _____ ft. total head, with a temperature of _____ °F, _____ NPSH required and _____ specific gravity. Each pump is to be furnished with a (standard) (high temperature) mechanical seal with all metal parts to be (303) (316) stainless steel with Buna-N elastomer, (ceramic) (tungsten carbide) seat, and carbon washer. The unit must be equipped with (bronze) (stainless steel) key-locked shaft sleeve that extends the length of the seal box. The pump shaft extension shall be O-ring sealed from the pumped liquid. Pump shall have case wearing rings.

Impellers are to be precision shell core cast, dynamically balanced and keylocked to the shaft.

Pump and motor are to be mounted on a common (formed steel drip rim) (steel) baseplate. The shaft is to be carbon steel, installed in a cast iron power frame. Pumps shall have a shaft design for .002" deflection at the seal face with the pump running under maximum load condition. (Grease) (Oil) lubricated ball bearings, having a 2 year minimum life (AFBMA B₁₀) under the maximum condition of load and protected by separate oil seals and slingers, shall be used. The pump shall be flexible coupled to a standard horizontal NEMA _____ HP, _____ phase, _____ Hertz, _____ volts, _____ RPM, (drip-proof) (totally enclosed) (hazardous location) motor. Alignment shall be checked in accordance with the Standards of the Hydraulic Institute after installation and there shall be no strain transmitted to pumps.



800 AIRPORT ROAD, NORTH AURORA, ILLINOIS 60542 WWW.AURORAPUMP.COM

Because we are continuously improving our products and services, Pentair reserves the right to change specifications without prior notice.
A-02-1013 12/20/12 © 2012 Pentair Ltd. All Rights Reserved.

