



# MODEL 410 SERIES

## SINGLE STAGE SPLIT CASE PUMPS

# ENGINEERING DATA GUIDE

[pentair.com](https://www.pentair.com)

# TABLE OF CONTENTS

---

<b>SECTION.....</b>	<b>PAGE</b>
Mechanical Seals And Packing .....	3
Interchangeability And Power Series .....	5
Materials Of Construction .....	6
Design Details .....	8
Engineering Data .....	9
Quiet Pump Selection .....	13
Shaft Deflection And Bearing Life .....	14
Engineering Data .....	15

# MECHANICAL SEALS AND PACKING

Standard packing on horizontal pumps and the standard mechanical seals on vertical pumps are suitable for most applications. Special sealing arrangements may however, be required due to higher pressure or temperature requirements and the nature of the liquid to be pumped. Factory option seals are of high quality and supplied by leading mechanical seal manufacturers. Various seal arrangements and types that better suit our specific needs are available. Seal faces are carbon vs. Ceramic on standard seals and carbon vs. Tungsten carbide on high temperature seals. Corrosion resistant alloy metal parts and Buna-N secondary sealing elements are provided. Various other metals are also available. Gland plates are cast iron and can be supplied in alternate materials. Recommendations and limitations are general. Specific selections can be offered only after rotating speeds, pressures, temperatures, type of equipment and liquid nature are known. The following illustrations describe the basic seal and packing options available. For options not shown refer to the factory. For quick reference for the type of seal best suited to your application, refer to the condensed information that heads each option. The following comments govern these recommendations:

**1 PACKING** Standard on Model 411. Not available on 412 & 413.  
**PRESSURES**(suction): Below atmospheric up to 250\*P.S.I.G. (Maximum pump limitation) Lantern rings are required on suction lift applications.

**TEMPERATURES:** From minus 100°F up to 275°F\* with high temperature packing, or 225°F with standard packing.

**LIQUIDS:** All liquids that are compatible with braided fiber packing. Other packings available for special applications.

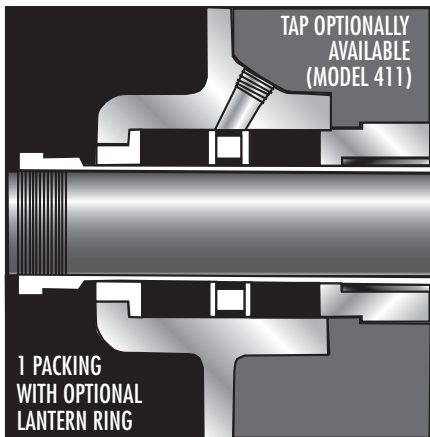

**2 SINGLE - UNBALANCED** Standard on Model 412 and 413. Optional Model 411.

**PRESSURES**(suction): Below atmospheric up to 100 P.S.I.G.

**TEMPERATURES:** From minus 100°F up to 275°F with high temperature seals, or 225°F with standard seals.

**LIQUIDS:** All liquids that are compatible with the seal materials of construction and with a specific gravity higher than .6.

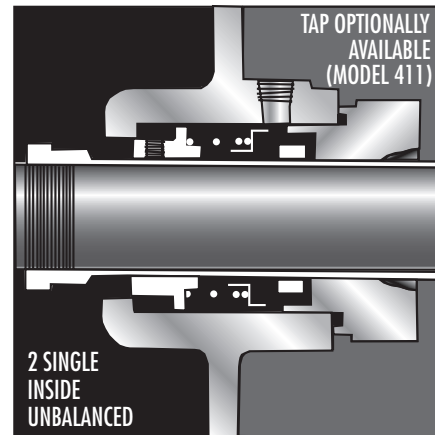

**3 SINGLE - BALANCED** Optional on all Models.

**PRESSURES**(suction): Up to 250 P.S.I.G. (Max. pump limit)

**TEMPERATURES:** Minus 100°F up to 275°F with high temperature seals, or 225°F with standard seals.

**LIQUIDS:** All liquids that are compatible with the seal materials of construction. Required on liquids with a specific gravity of .6 or lower.

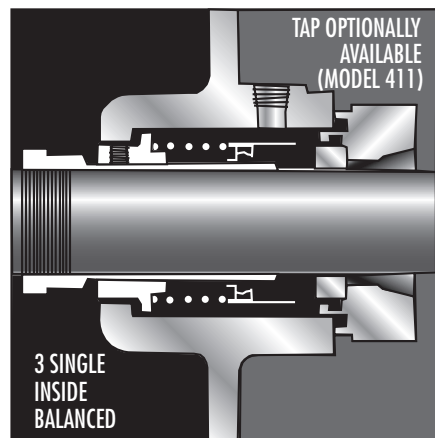

# MECHANICAL SEALS AND PACKING

**PRESSURES** - The pressures referred to are those found at the pump suction. Most seal manufacturers recommend a flushing arrangement from the discharge to the stuffing box where "below atmospheric pressure" is encountered. The 410 Series stuffing boxes incorporate internal bypass arrangements which permit flushing to the mechanical seals. External bypasses are available to both seal faces. An external bypass is standard on vertical pumps to the upper seal face.

**TEMPERATURES** - The temperature limitation of a mechanical seal is frequently determined by the shaft sealing material. The various elastomer "O" ring materials have varying temperature limits, depending upon the chemical and/or physical properties of the process fluid. Filled TEFLON†, shaft seal rings are available.

**LIQUIDS** - due to varying degrees of resistance of various sealing compounds in different pumped liquids, the following mechanical seal sealing rings are available: BUNA-N, NEOPRENE, VITON, TEFLON† and other synthetic elastomers.

†DUPONT registered trademark.

\*NOTE: hardened stainless steel (450 minimum brinell) shaft sleeves are available with this option and are required when the suction pressure is over 100 P.S.I.G. or when the temperature exceeds 225°F.

## INTERCHANGEABILITY AND PS

Aurora Models 411, 412 and 413 were designed for maximum interchangeability. Each model is available in 34 different sizes, offering a model and size precisely fitted to the installation requirements. The 34 sizes are divided into 7" power series. Within each power series, all parts are completely interchangeable except for the impeller, casing and case wearing rings for the right hand or left hand rotation. See the illustration below for all details.

## POWER SERIES

1	2	3	4	4A	5	5A	6B	7*	7A		
2x2-1/2x9	2-1/2x3 x10B	4x5x11A	-	5x6x17	6x8x11HH	6x8x15	8x10x12	6x8x14HH	10x12x12B	8x12x24	10x12x18D
2x2-1/2x10	2-1/2x3x12	4x5x11C	4x6x18B	6x8x11	6x8x18A	-	10x12x15B	12x14x15B			
2x2-1/2x12	3x4x10B	4x5x11D	5x6x11	8x8x11B	6x8x18B	8x10x15A	10x12x15C*	12x14x18			
	3x4x14	4x5x15	5x6x11C		6x8x18C	8x10x15B	10x12x18*	14x16x18			
	4x5x10B		5x6x15		6x8x20	8x10x17B					

Pump Size Example: 3x4x14(3-Discharge Dia.)(4-Suction Dia.)(14-Approx. Max. Impeller Dia.)

\*Model 411 Pumps Only

# INTERCHANGEABILITY AND POWER SERIES

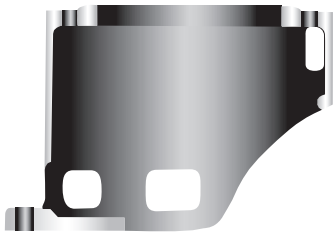

MODEL 413  
MOTOR BRACKETS

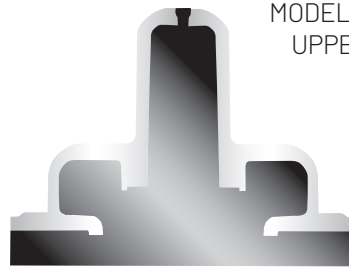

MODEL 411, 412 & 413  
UPPER CASINGS

MODEL 412 & 413  
LOWER CASINGS



Model 411, 412 & 413  
Shaft assemblies (power series)  
Complete rotating assembly  
Consisting of a shaft,  
Shaft sleeves,  
Gaskets,  
Keys, inboard  
Bearing assembly,  
Outboard bearing assembly  
And packing or mechanical seal assemblies  
are interchangeable For all pumps within each  
power series.

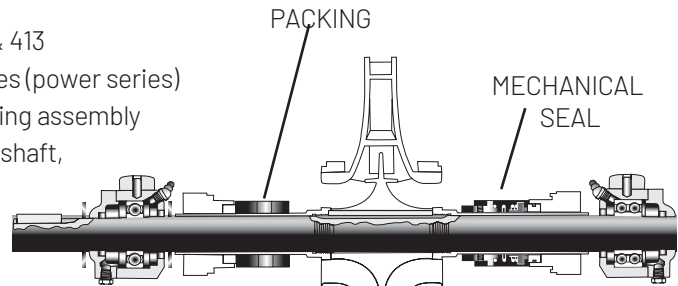

PACKING

MECHANICAL  
SEAL

MODEL 411, 412 & 413  
CASE WEAR RINGS

MODEL 411, 412 & 413  
IMPELLERS

MODEL 412 & 413  
DRIP RIM BASES



MODEL 411  
LOWER CASINGS

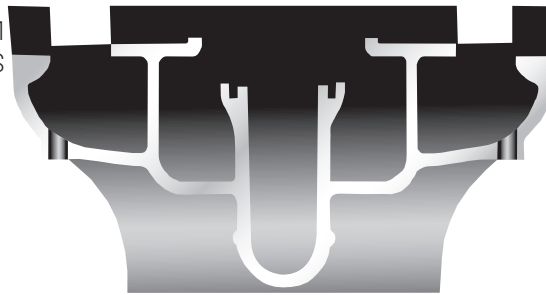

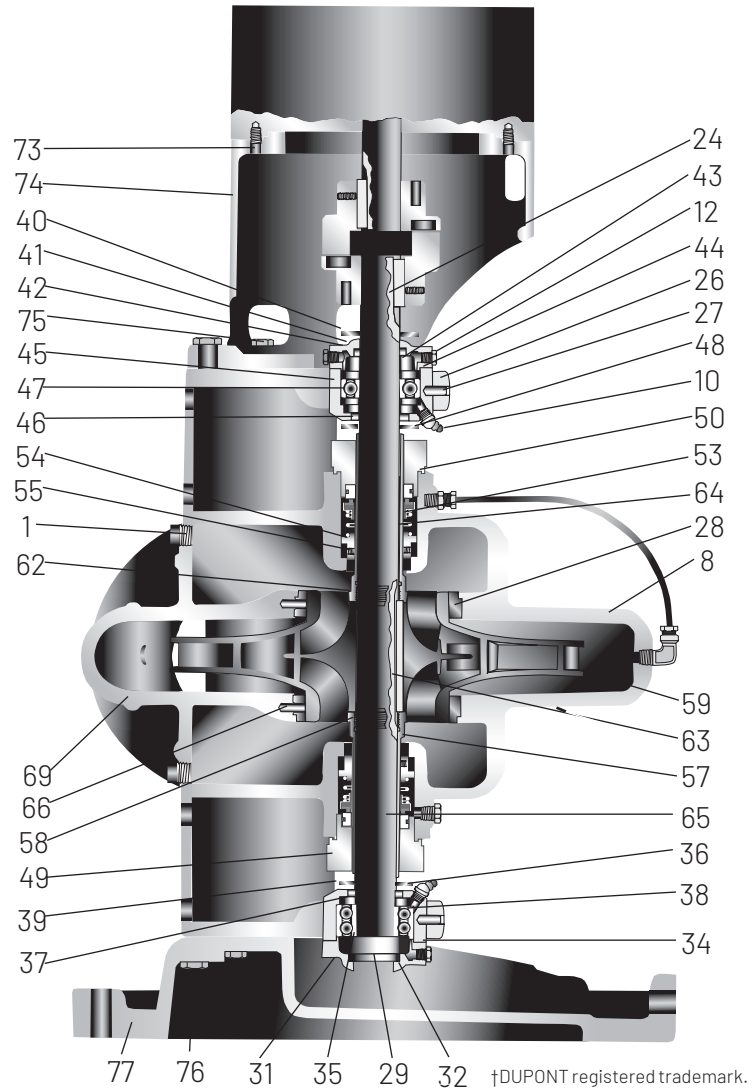

# MATERIALS OF CONSTRUCTION

PC NO.	DESCRIP. (*NOTSHOWN)	PUMP CONSTRUCTION		
		BRONZE FITTED	ALL IRON	STAIN. STEEL
1	Plug			
2	*Plug	Mall. Iron A197	Mall. Iron A197	Stain..Stl. AISI 316
6	*Capscrew			
7	*Capscrew	Steel SAE 2	Steel SAE 2	Stain.Stl. AISI 316
8	Casing Half	Cast Iron A48	Cast Iron A48	Stain.Stl. ACI CF8M
9	*Gasket		Buna-N Treated Cellulose	
10	Gr. Ftg.		Steel Zerk	
12	Plug		Malleable Iron ASTM A197	
18	*Nut	Bronze Wrought	Steel SAE 2	Stain.Stl. AISI 316
19	*Washer			
20	*Gland Clamp	Cad. Plated Steel	Cad. Plated Steel	Stain. Stl. AISI 316
21	*Gland	Cast Iron A48	Cast Iron A48	Stain. Stl. ACI CF8M
22	*Swing Bolt	Cad. Plated Steel	Cad. Plated Steel	Stain. Stl. AISI 316
23	*Packing		Graphited Acrylic	
24	Key		Steel Wrought	
25	*Capscrew	Steel SAE 2	Steel SAE 2	Stain. Stl. AISI 316
26	Bearing Cap	Cast Iron A48	Cast Iron A48	Stain. Stl. ACI CF8M
27	Pin	Cad. Plated Steel	Cad. Plated Steel	Stain. Stl. AISI 316
28	Case Ring	Bronze ASTM B62	Cast Iron A48	Stain. Stl. ACI CF8M
29	Protector		Steel Wrought	
31	Capscrew		Steel SAE 2	
32	Cart. Cap		Cast Iron ASTM A48	
34	Gasket		Buna-N Treated Cellulose	
35	Ret. Ring		Spring Steel	
36	Cartridge		Cast Iron ASTM A48	
37	Gr. Seal		Buna-N and Seal	
38	Bearing		Steel Commercial	
39	Slinger		Neoprene	
40	Slinger		Neoprene	
41	Capscrew		Steel SAE 2	
42	Car. Cap		Cast Iron ASTM A48	
43	Gr. Seal		Buna-N and Steel	
44	Gasket		Buna-N Treated Cellulose	
45	Cartridge		Cast Iron ASTM A48	
46	Gr. Seal		Buna-N and Steel	
47	Bearing		Steel Commercial	
48	Slinger		Neoprene	
49	Gland	Cast iron A48	Cast Iron A48	Stain. Stl. ACI CF8M
50	O-Ring		Buna-N	
52	*Lantern Ring	Bronze ASTM B62	Cast Iron A48	Stain. Stl. AC CF8M
53	Seal	Stain. Stl.(1)	Stain. Stl.(1)	Stain. Stl.(2)
54	Collar	Bronze ASTM B62	Cast Iron A48	Stain. Stl. AISI 316
55	Setscrew	Stainless Steel AISI 316		
56	*Bushing	Bronze ASTM B62	Cast Iron A48	Stain. Stl. AISI 316
57	Sleeve	Bronze High Lead Tin	Stain. Stl. AISI 316	
58	Gasket		DuPont TFE Coated Steel	
59	Impeller	Bronze ASTM B584	Cast Iron A48	Stain. Stl. ACI CF8M
61	*Imp. Ring	Bronze ASTM B62		
62	Gasket		DuPont TFE Coated Steel	
63	Key	Stain. Stl. AISI 416	Stain. Stl. AISI 416	Stain. Stl. AISI 316
64	Sleeve	Bronze High Lead Tin		Stain. Stl. AISI 316
65	Shaft P.S	P.S. 1-5	Stain. Stl. AISI 316	Stl. AISI C1045
	1-5	6B-7	(3)	Alloy Stl.
	6B-7	Alloy Stl.	Alloy Stl.	(3)
66	Pin			
67	*Pin	Cad. Plated Steel	Cad. Plated Steel	Stain. Steel AISI 316
68	*Pin			
69	CasingHalf	Cast Iron A48	Cast Iron A48	Stain. Stl. ACI CF8M
70	*Drive Screw		Steel Bronze Plated	
71	*Nameplate		Stainless Steel AISI 303	
73	Capscrew		Steel SAE 2	
74	Bracket		Cast Iron ASTM A48	
75	Capscrew		Steel SAE 2	
76	Capscrew		Steel SAE 2	
77	Base		Cast Iron ASTM A48	

\*All material specifications are in accordance with ASTM unless otherwise noted. (1)B30P66171(JC)(2)XP661C1(JC)(3)AISI 416 chrome steel heat treated power series 6B-7.

# DESIGN DETAILS

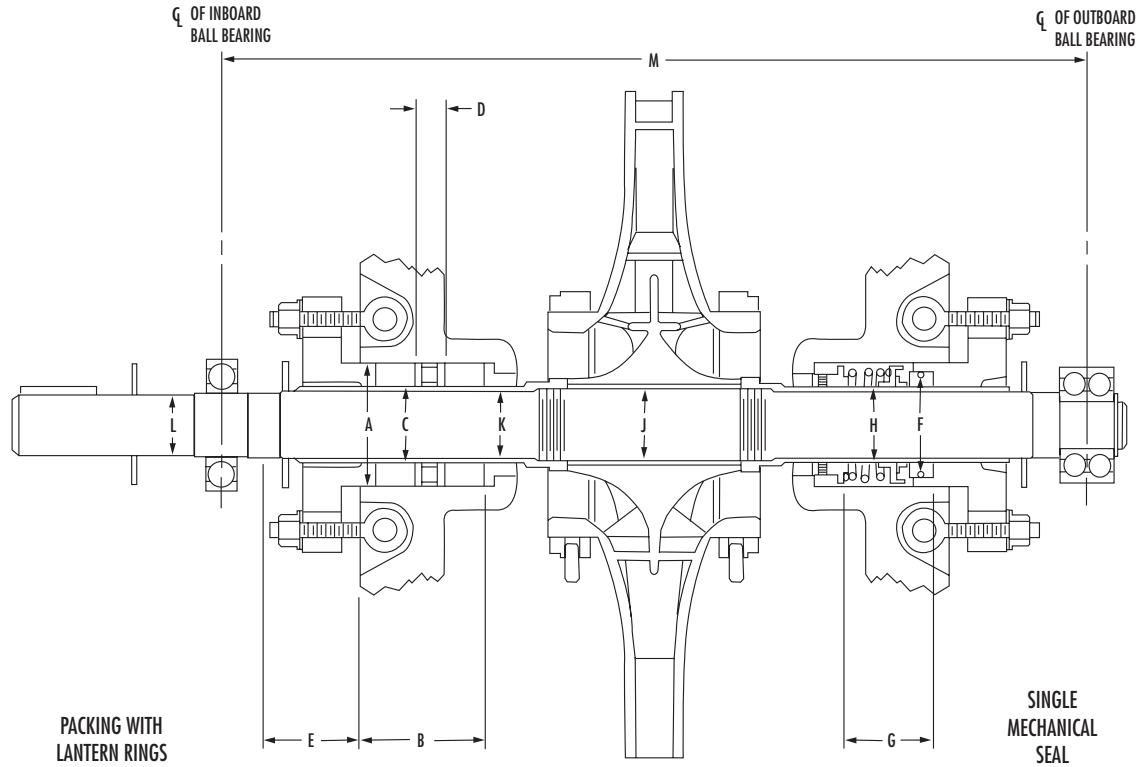

PUMP PART	DIMENSION	POWER 1 SERIES	POWER 2 SERIES	POWER 3 SERIES	POWER 4 SERIES	POWER 4A SERIES	POWER 5 SERIES	POWER 5A SERIES	POWER 6B SERIES	POWER 7 SERIES	POWER 7B SERIES	
STUFFING BOX	PACKING	A Stuffing Box Bore Dia.	2-1/16	2-7/16	2-13/16	3-1/16	3-1/16	3-7/16	3-7/16	3-11/16	3-15/16	4
		B Stuffing Box Depth	2-3/8	3-1/8	3	3-1/2	3-1/2	3-3/4	3-3/4	3-3/4	3-7/8	4-3/8
		C Outside Dia., Sleeve for Packing	1-1/8	1-1/2	1-3/4	2	2	2-3/8	2-3/8	2-1/2	2-7/8	3
		- No. of Packing Rings without Lantern Ring	10	12	10	12	12	12	12	12	14	12
		- Total number of Packing Rings with Lantern Ring	8	10	8	10	10	10	10	10	12	10
	M. SEAL	- No. of rings in front of Lantern Ring	1	2	2	2	2	2	2	2	3	2
		- Packing Size	7/16 Sq..	7/16 Sq..	1/2 Sq..	1/2 Sq..	1/2 Sq..	1/2 Sq..	1/2 Sq..	9/16x1/2	1/2Sq..	1/2 Sq..
		D Width of Lantern Ring	1/2	5/8	5/8	5/8	5/8	3/4	3/4	3/4	3/4	3/4
		E Distance from Box to Nearest Obstruction	1-1/4	1-5/8	1-11/16	1-11/16	1-11/16	2	2	2-3/8	2-1/2	2-5/8
		F Dia. of Mechanical Seal Seat	1-3/4	2-1/8	2-1/2	2-3/4	2-3/4	3-1/4	3-1/4	3-3/8	3-3/4	3-7/8
SHAFT	G Length of Mechanical Seal	1-1/2	1-9/16	1-7/8	2	2	2-3/8	2-3/8	2-3/8	2-7/8	3-1/2	
	H Outside Dia., Sleeve for Mech. Seal	1-1/8	1-1/2	1-3/4	2	2	2-3/8	2-3/8	2-1/2	2-7/8	3	
	J Dia. at Impeller (Max. Shaft Dia.)	1-1/8	1-3/8	1-5/8	1-7/8	1-7/8	2-1/8	2-1/8	2-3/8	2-3/4	2-3/4	
	K Diameter of Shaft Sleeve	7/8	1-1/4	1-1/2	1-3/4	1-3/4	2	2	2-1/4	2-5/8	2-5/8	
BALL BEARINGS	L Diameter at Coupling End	3/4	1-1/8	1-3/8	1-1/2	1-1/2	1-3/4	1-3/4	2-1/8	2-1/2	2-1/8	
	- Max. deflection at Sealing Face	.002	.002	.002	.002	.002	.002	.002	.002	.002	.002	
	- Ball Bearing No. (Inboard Radial)	204	206	207	208†	208	309	309	211	213	211	
	- Ball Bearing No. (Outboard Thrust)	5303	5305	5306	5307	5307	5309	5309	5211	5213	5211	
	M Bearing Centers	14-3/4	18-3/8	19-3/8	21-1/4	25-3/8	24	28-1/2	28-3/8	33-1/8	33	
- Minimum Life of Bearing under worst conditions of load (*)	6 YEARS	6 YEARS	6 YEARS	6 YEARS	6 YEARS	6 YEARS	6 YEARS	6 YEARS	6 YEARS	6 YEARS	6 YEARS	

\* Average life of bearings is 5 times minimum life  
 † 5208 is provided as standard on 5x6x11B when operating at 3500 RPM



# ENGINEERING DATA

MAXIMUM CASE WORKING PRESSURE is the sum of the differential pressure and the suction pressure. Table 2 indicates the maximum case working pressure for the 410 Series Split Case Pumps in various materials at the various operating temperatures. These maximum allowable pressures are based on wall thickness for the particular series of pumps, ratings of American Standard Flange Specifications, see Table 1, and take into account the material at various allowable temperatures. Table 1 offers the available casing material and flange ratings for the 410 Series Split Case Pumps.

EXTERNAL INERTIA OR FLYWHEEL EFFECT is the Kinetic energy stored in the rotating assembly that must be overcome when the pump impeller is caused to rotate within the casing. This energy frequently must be calculated to determine the torque required to start, accelerate or decelerate the pump. If the acceleration is rapid, the torque may be several times greater than the torque required to run the pump at normal or constant speed. WR2 values in LBS-FT<sup>2</sup> are provided for these calculations. See tables 3 thru 8.

WR2 values given in table are for bronze impeller...LBFT<sup>2</sup>

EXAMPLE: A model 410 Pump with a bronze casing has been selected for operating at a case working pressure of 240 PSIG at 150°F. Enter Table 2 at 150°F and read upward to 240 PSIG. It is determined that the selection is within the recommended maximum case working pressure area for 300 PSI flanges and is therefore acceptable. Note that the example exceeds the maximum case working pressure unit if the material selected would have been 125 PSI flanged cast iron or 150 PSI flanged bronze.

EXAMPLE 1: Find WR<sup>2</sup> value for a 15" diameter 8x10x15B bronze fitted pump handling cold water.

TABLE - 1 PUMP CASING MATERIAL	MINIMUM REQUIREMENT FOR STANDARD SUCTION AND DISCHARGE FLANGES		PIPE SIZE	CODE
	A.S.A. Spec.	Classification		
Cast Iron ASTM A48	B16.1	125 PSI Flat Face	1-12 14-24	A B
		250 PSI Flat Face	1-12 14-24	C
Stainless Steel ASTM 296 Grade CF8M	B16.5	150 PSI Flat Face	All	E
		300 PSI Flat Face		C

TABLE - 3 VALUE OF ROTATING ELEMENT LESS IMPELLER	
Power Series	S.G.
Bronze	8.86
Cast Iron	7.20
Carbon Steel	7.84
Stainless Steel	7.90

From chart the "WET" value for

a 15" diameter impeller .....10.38 LBS-FT<sup>2</sup>

Add power series 5 rotating element

less impeller.....0.15 LBS-FT

Total 10.53 LBS-FT

EXAMPLE 2: Find WR<sup>2</sup> value for a 15" diameter 8x10x15B all iron pump handling 0.67 specific gravity gasoline.

From chart the "DRY" value and correct for difference in materials.

SP. GR. cast iron

SP. GR. bronze

Take difference ("WET"- "DRY") values and correct for difference in specific gravities.

1.09x0.67..... 0.73 LBS-FT<sup>2</sup>

Add power series 5 rotating element

less impeller.....0.15 LBS-FT

Total 10.53 LBS-FT<sup>2</sup>

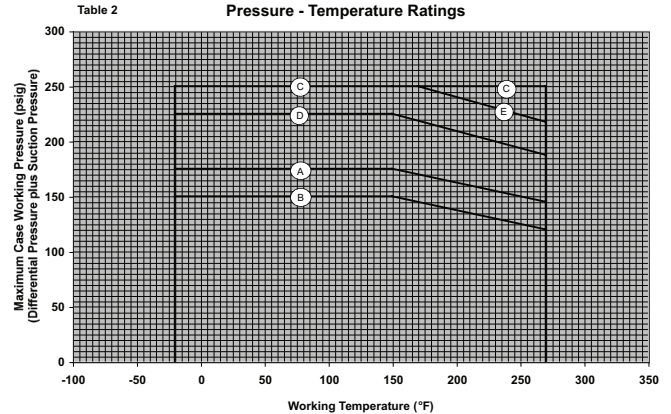

TABLE - 4 VALUE OF ROTATING ELEMENT LESS IMPELLER	
Power Series	WR <sup>2</sup>
1	0.006
2	0.020
3	0.038
4	0.075
4A	0.087
5	0.154
5A	0.181
6B	0.294
7	0.536
7A	0.413

# ENGINEERING DATA

TABLE 5	2X2-1/2X9		2X2-1/2X10		2-1/2X3X10B		3X4X10B		4X5X10B	
	DIA.	Dry	Wet	Dry	Wet	Dry	Wet	Dry	Wet	Dry
10"	-	-	-	-	-	-	1.17	1.30	-	-
9.5"	-	-	0.72	0.88	0.84	0.95	0.98	1.10	0.90	1.03
9.0"	0.56	0.63	0.60	0.70	0.70	0.85	0.80	0.90	0.80	0.90
8.5"	0.37	0.43	0.46	0.54	0.62	0.73	0.70	0.75	0.68	0.75
8.0"	0.28	0.32	0.40	0.47	0.56	0.65	0.56	0.60	0.56	0.63
7.5"	0.23	0.26	0.36	0.41	0.47	0.56	0.46	0.50	0.48	0.54
7.0"	0.19	0.22	0.29	0.33	0.42	0.49	0.36	0.40	0.43	0.46
6.5"	0.18	0.19	0.27	0.31	0.39	0.44	0.32	0.36	0.38	0.41
6.0"	0.21	0.18	-	-	0.35	0.41	0.28	0.31	0.33	0.36
IMP. WT.	10#		12#		14#		18#		15#	

TABLE 6	2X2-1/2X12		2-1/2X3X12		4X5X11A		4.5X11C		4X5X11D		5X6X11 6X8X11		5X6X11C		6X8X11HH		8X8X11B		8X10X12		10X12X12B		
	DIA.	Dry	Wet	Dry	Wet	Dry	Wet	Dry	Wet	Dry	Wet	Dry	Wet	Dry	Wet	Dry	Wet	Dry	Wet	Dry	Wet	Dry	Wet
12"	1.55	1.82	1.70	1.95	-	-	-	-	-	-	-	-	-	-	-	-	-	2.91	3.43	4.10	4.60	5.80	6.75
11.5"	1.25	1.45	1.40	1.55	-	-	-	-	-	-	-	-	-	-	-	-	-	2.55	3.00	3.80	4.00	5.32	6.10
11.0"	1.05	1.20	1.10	1.25	1.90	2.10	1.65	1.80	-	-	2.04	2.47	3.00	3.60	3.36	2.76	2.15	2.45	3.40	3.80	5.00	5.60	
10.5"	0.93	1.04	0.98	1.10	1.60	1.75	1.45	1.55	1.28	1.23	1.80	2.10	2.90	3.20	3.03	2.49	1.95	2.20	3.10	3.30	4.90	5.50	
10.0"	0.81	0.90	0.83	0.90	1.35	1.52	1.22	1.35	1.18	1.14	1.60	1.85	2.65	3.10	2.74	2.25	1.73	1.95	2.85	3.10	4.80	5.40	
9.5"	0.75	0.83	0.68	0.75	1.20	1.33	1.08	1.19	1.00	1.05	1.45	1.65	2.50	2.90	2.48	2.04	1.50	1.66	2.70	2.90	-	-	
9.0"	0.70	0.78	0.60	0.67	1.05	1.22	1.00	1.10	1.09	0.97	1.30	1.45	2.40	2.80	2.25	1.86	1.40	1.50	2.60	2.70	-	-	
8.5"	-	-	-	-	0.95	1.05	0.88	0.99	0.95	0.89	1.20	1.35	2.35	2.60	2.06	1.72	1.30	1.40	2.50	2.60	-	-	
8.0"	-	-	-	-	0.83	0.95	0.75	0.84	0.88	0.83	1.06	1.15	2.00	2.40	1.90	1.60	1.15	1.20	-	-	-	-	
7.5"	-	-	-	-	-	-	0.73	0.80	0.78	0.75	0.93	1.05	1.90	2.20	1.78	1.51	1.09	1.12	-	-	-	-	
7.0"	-	-	-	-	-	-	0.65	0.74	0.75	0.69	-	-	-	-	-	-	-	-	-	-	-	-	
IMP. WT.	15#		17#		26#		22#		24#		27#		32#		37#		29#		43#		59#		

# ENGINEERING DATA

TABLE 7	3X4X14		4X5X15		5X6X15		6X8X14HH		8X10X15 6X8X15		8X10X15B		10X12X15B		10X12X15C		12X14X15B	
	DIA.	Dry	Wet	Dry	Wet	Dry	Wet	Dry	Wet	Dry	Wet	Dry	Wet	Dry	Wet	Dry	Wet	Dry
15"	-	-	4.51	5.18	6.18	6.76	-	-	7.39	8.51	9.29	10.4	9.20	10.0	14.5	17.5	14.3	17.7
14.5"	-	-	3.80	4.50	5.40	6.00	-	-	6.75	7.50	7.75	8.80	8.50	9.25	13.5	16.2	14.0	16.5
14.0"	3.62	4.36	3.50	3.90	4.60	5.20	7.50	6.63	6.00	6.75	6.75	7.75	8.00	9.00	12.2	14.4	13.0	15.0
13.5"	3.10	3.60	3.00	3.40	4.20	4.50	6.97	6.16	5.40	6.00	6.10	7.00	7.50	8.50	11.3	12.2	12.5	14.5
13.0"	2.70	3.10	2.55	2.95	3.60	3.90	6.46	5.69	5.00	5.50	5.70	6.25	6.75	7.60	10.5	11.4	11.8	13.9
12.5"	2.25	2.65	2.20	2.60	3.20	3.50	5.97	5.27	4.50	5.00	5.10	5.80	6.50	7.25	10.0	11.0	11.0	13.0
12.0"	1.98	2.30	1.95	2.25	3.05	3.20	5.48	4.83	4.10	4.40	4.80	5.30	6.25	7.00	-	-	10.5	12.5
11.5"	1.60	1.90	1.70	2.00	2.70	2.98	5.06	4.45	3.70	4.00	4.50	5.00	-	-	-	-	-	-
11.0"	1.40	1.65	1.50	1.75	2.50	2.70	4.62	4.06	3.30	3.55	4.10	4.40	-	-	-	-	-	-
10.5"	1.25	1.50	-	-	2.30	2.45	4.23	3.70	3.00	3.20	3.70	4.10	-	-	-	-	-	-
10.0"	1.10	1.35	-	-	2.05	2.25	3.87	3.38	2.85	3.10	3.50	3.80	-	-	-	-	-	-
9.5"	-	-	-	-	-	-	3.47	3.02	-	-	-	-	-	-	-	-	-	-
9.0"	-	-	-	-	-	-	3.11	2.69	-	-	-	-	-	-	-	-	-	-
IMP. WT.	28#		30#		45#		62#		56#		59#		70#		85#		87#	

TABLE 8	4X6X18B		5X6X17		6X8X18A,B,C		6X8X20		8X10X17B		10X12X18		10X12X18D		8X12X24		12X14X18		12X14X18	
	DIA.	Dry	Wet	Dry	Wet	Dry	Wet	Dry	Wet	Dry	Wet	Dry	Wet	Dry	Wet	Dry	Wet	Dry	Wet	Dry
24.0"	-	-	-	-	-	-	-	-	-	-	-	-	-	-	50.1	52.5	-	-	-	-
22.5"	-	-	-	-	-	-	-	-	-	-	-	-	-	-	44.0	46.5	-	-	-	-
21.0"	-	-	-	-	-	-	-	-	-	-	-	-	-	-	38.0	40.5	-	-	-	-
19.5"	-	-	-	-	-	-	18.0	20.3	-	-	-	-	-	-	35.0	35.5	-	-	-	-
19.0"	-	-	-	-	-	-	16.5	19.0	-	-	-	-	-	-	-	-	-	-	-	-
18.5"	-	-	-	-	-	-	15.0	17.2	-	-	-	-	-	-	-	-	-	-	-	-
18.0"	11.60	13.50	-	-	15.0	18.0	14.0	15.4	-	-	19.5	22.6	-	-	-	-	30.0	32.0	46.0	48.0
17.5"	10.80	12.0	-	-	13.0	16.0	12.60	14.3	16.5	18.5	18.5	21.0	27.78	21.29	-	-	25.0	29.0	40.0	42.0
17.0"	10.10	11.10	-	-	11.5	13.5	11.40	13.4	15.2	16.5	17.0	19.5	26.12	20.15	-	-	22.0	26.5	36.0	39.0
16.5"	9.50	10.30	8.64	9.69	10.0	11.6	10.50	12.0	12.6	14.5	15.5	18.5	24.46	19.01	-	-	20.0	24.0	31.0	34.0
16.0"	9.00	9.50	8.00	9.00	8.80	9.70	9.93	11.2	11.5	13.0	14.0	17.1	22.95	17.97	-	-	17.5	21.5	28.0	31.5
15.5"	8.81	8.90	7.30	8.30	7.50	8.80	9.00	10.0	10.0	11.5	13.1	16.0	21.43	16.93	-	-	15.5	19.5	25.0	29.0
15.0"	-	-	6.80	7.80	6.70	7.00	8.10	9.25	9.10	9.10	12.0	14.5	20.08	15.99	-	-	14.0	18.0	22.5	27.5
14.5"	-	-	6.00	7.00	6.00	6.50	7.36	8.28	7.50	8.60	-	-	18.72	15.05	-	-	-	-	-	-
14.0"	-	-	5.30	6.20	-	-	-	-	-	-	-	-	-	-	-	-	-	-	-	-
13.5"	-	-	4.90	5.80	-	-	-	-	-	-	-	-	-	-	-	-	-	-	-	-
13.0"	-	-	4.40	5.20	-	-	-	-	-	-	-	-	-	-	-	-	-	-	-	-
IMP. WT.	28#		30#		45#		56#		59#		70#		166#		105#		85#		87#	

# QUIET PUMP SELECTION

QUIET PUMP operation is always a desirable and sometimes essential. One of the most important factors for noise control in a pumping installation is the correct selection of a pumping unit for the system. To insure that the pump will run quietly, it should be selected so that it will operate as close as possible to the best efficiency point. At this point the hydraulic shock within the pump is at a minimum since the flow angle of the fluid from the tip of the impeller is correct for the casing design. Every pump is designed for the best efficiency point and operations at any other point on the characteristic curves is a compromise. The amount of turbulence on either side of the best efficiency point increases as the point of operation is moved along the curve from the maximum efficiency. Therefore, the greater the turbulence, the greater the noise generated.

Hydraulic shock is also a factor if the periphery of the impeller passes too close to the cutwater. If the ratio of the impeller diameter to the cutwater diameter in centrifugal pumps is greater than 0.92, the pump is likely to be hydraulically noisy. In such instances the hydraulic pulses are actually differential pressures that occur when the impeller vanes pass the cutwater. Cutwater ratios of 0.9 to 0.95 are typical; however, significantly lower noise levels are achieved in pumps designed with a ratio of 0.7 to 0.75. Although there is an optimum gap for pump efficiency, increases of only 3%-5% may be realized by using the optimum. A cutwater ratio of 0.85 is commonly specified by practicing engineers, thereby realizing a minimum reduction in pump efficiency with a mean reduction in noise level. Table 9 offers recommended quiet impeller diameter at 85% cutwater ratio.

BEARING LIFE is based on the radial and thrust loads imposed on the bearings at the specific operating head and suction pressure. The Split case pump is designed for a six year minimum B10 life at the maximum recommended loads. Bearing life at any other point of greater capacity on the curves will greatly exceed the minimum life shown. Average bearing life is equal to five (5) times the minimum bearing life. Tables 11, 12, 13, and 14 will enable you to determine the minimum radial and thrust bearing life for any type 410 Series pump size.

SHAFT DEFLECTION is the consequence of the unbalanced hydraulic force acting inside the pump on the impeller and shaft in a radial direction. This unbalance occurs when the pump is operating away from its best efficiency point. At shut-off condition (zero flow) the unbalance is greatest and therefore the resultant radial load is maximum. Radial load and shaft deflection approach zero at the best efficiency point of the pump. 410 Series pumps are designed for a maximum deflection of .002" at the mechanical seal faces when operating at the maximum recommended differential pressure. Deflection in a twin volute pump is minimized by a splitter blade that is cast within the casing thereby nearly balancing the resultant forces acting on the shaft. See Table 13.

Procedure for determining maximum shaft deflection and minimum bearing life.

1. Determine the proper Pump Size, approximate Shut-Off Head in feet, Power Series number, and Speed from the range charts illustrated in the 410 bulletin.
2. From table 11 determine the Pump Size Factor based on Pump Size and R.P.M.
3. On table 13 locate the correct Shut-Off Head in feet and read across to the proper Pump Size Factor and down to the applicable Power Series. Note the Load Factor in the process. Read to the scale on the left for the maximum Shaft Deflection value.
4. From table 14 using the Load Factor from step 3 above read across to the correct Power Series number and down for the minimum Bearing Life in hours.

**NOTE:** 1. One (1) year life is based on 8740 HOURS (continuous operation). 2. Additional bearing information can be found on page 74. 3. Specific information on Bearing Life and Shaft Deflection can be obtained from the factory.

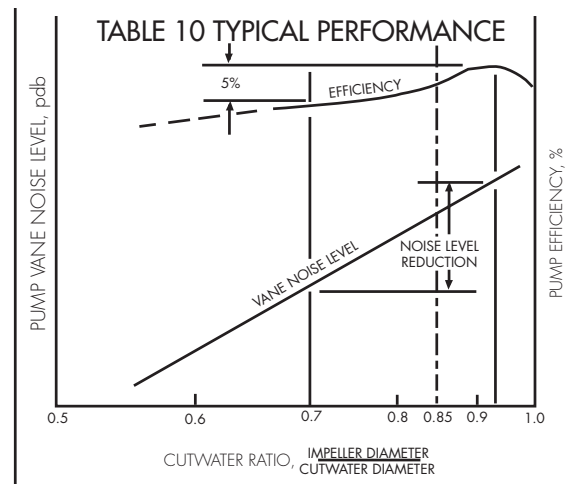

# QUIET PUMP SELECTION

TABLE 9	MAX IMP.	CUT WATER	QUIET IMP.	SPHERE SIZE
PUMP SIZE	DIA.	DIA.	DIA.	DIA.
2x2-1/2-9	9.0	10.4	8-13/16	1/8
2x2-1/2x10	9.5	10.3	8-11/16	1/4
2x2-1/2-12	12.0	13.3	11-1/4	1/4
2-1/2x3x10B	9.5	10.3	8-11/16	3/8
2-1/2x3x12	12.0	13.3	11-3/8	3/8
3x4x10B	10.0	10.5	8-13/16	1/2
3x4x14	14.0	15.4	13-1/16	5/8
4x5x10B	9.5	10.6	9-1/16	5/8
4x5x11A	11.3	12.8	10-7/8	5/8
4x5x11C	11.3	12.8	10-7/8	1/2
4x5x11D	11.0	12.8	10-7/8	3/8
4x5x15	15.0	16.4	13-15/16	5/8
4x6x18B	18.3	22.6	18-1/4	9/16
5x6x11	11.0	12.6	10-3/4	1
5x6x11C	11.0	12.6	10-3/4	5/8
5x6x15	15.0	16.4	13-7/8	13/16
5x6x17	16.5	17.4	14-3/4	11/16
6x8x11	11.0	12.8	10-7/8	1
6x8x11HH	11.0	11.5	9-3/4	3/4
8x8x11B	12.0	13.3	11-1/4	1-1/4
6x8x14HH	14.0	14.25	12-1/8	11/16
6x8x15	15.0	16.6	14-1/8	15/16
6x8x18A	18.0	20.5	17-7/8	1
6x8x18B	18.0	20.5	17-7/8	1
6x8x18C	18.0	20.5	17-7/8	1
6x8x20	19.5	20.6	17-9/16	13/16
8x10x12	12.0	14.4	12-1/4	15/16
8x10x15A	15.0	16.8	14-1/4	15/16
8x10x15B	15.0	16.8	14-1/4	1-5/16
8x10x17B	17.5	18.5	15-3/4	1-5/16
10x12x12B	12.0	14.0	11-15/16	15/16
10x12x15B	15.0	17.1	14-9/16	1-7/16
10x12x15C	15.0	17.1	14-9/16	1-1/8
10x12x18	18.0	20.5	17-7/16	1-9/16
10x12x18D	17.5	18.5	15-3/4	1-5/16
8x12x24	24	21.6	18-3/8	1
12x14x15B	15.0	17.8	15	1-1/16
12x14x18	18.0	21.1	18	1-5/16
14x16x18	18.0	22.0	18	1-1/2

# SHAFT DEFLECTION AND BEARING LIFE

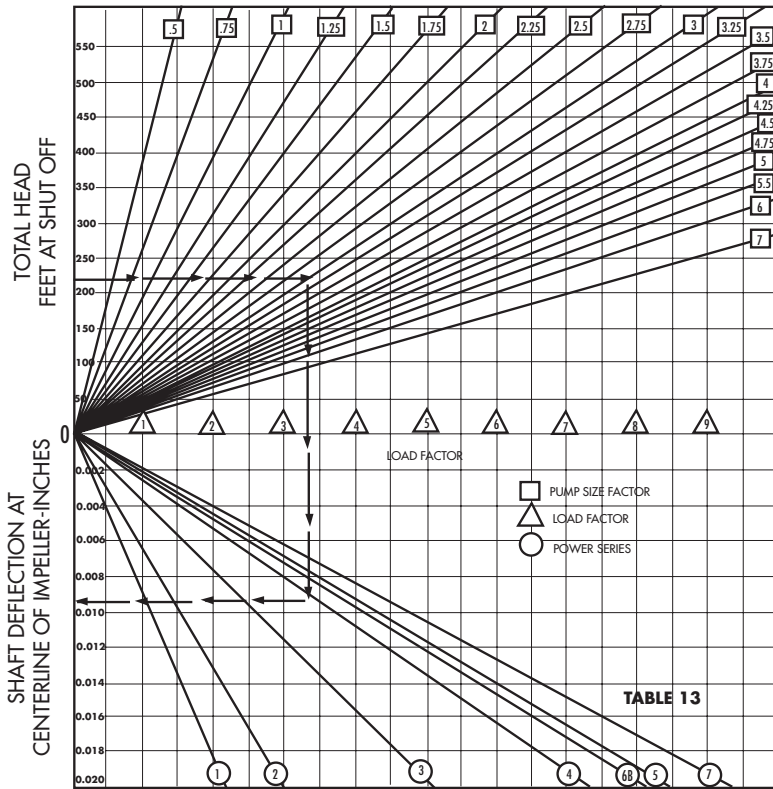

The charts reflect the worst possible conditions at pump shut-off. The effect from impeller, shaft sleeves, wearing rings and packing will reduce the amount of deflection.

PUMP SIZE	POWER SERIES	PUMP SIZE FACTOR		
		3500 RPM	1750 RPM	1150 RPM
2x2-1/2-9	1	0.40	0.50	
2x2-1/2x10	1	0.55	0.65	
2x2-1/2-12	1		0.65	0.80
2-1/2x3x10B	2	1.00	1.00	
2-1/2x3x12	2		1.00	1.20
3x4x10B	2	1.25	1.50	
3x4x14	2		1.40	1.60
4x5x10B	2	1.30	1.40	
4x5x11A	3		2.00	2.25
4x5x11C	3	1.50	1.70	
4x5x11D	3	1.85	4.00	
4x5x15	3		2.00	2.25
4x6x18B	4		1.70	1.80
5x6x11	4		4.00	4.50
5x6x11C	4	2.00	2.13	
5x6x15	4		3.00	3.25
5x6x17	4		3.00	3.25
6x8x11	4		4.00	4.50
8x8x11B	4		5.25	5.50
6x8x15	5		3.75	4.00
6x8x18A	5		3.00	3.25
6x8x18B	5		2.75	3.50
6x8x18C	5		3.75	4.75
6x8x20	5		3.20	3.40
8x10x12	5		3.50	4.00
8x10x15A	5		4.00	4.50
8x10x15B	5		4.50	5.00
8x10x17B	5		4.00	5.00

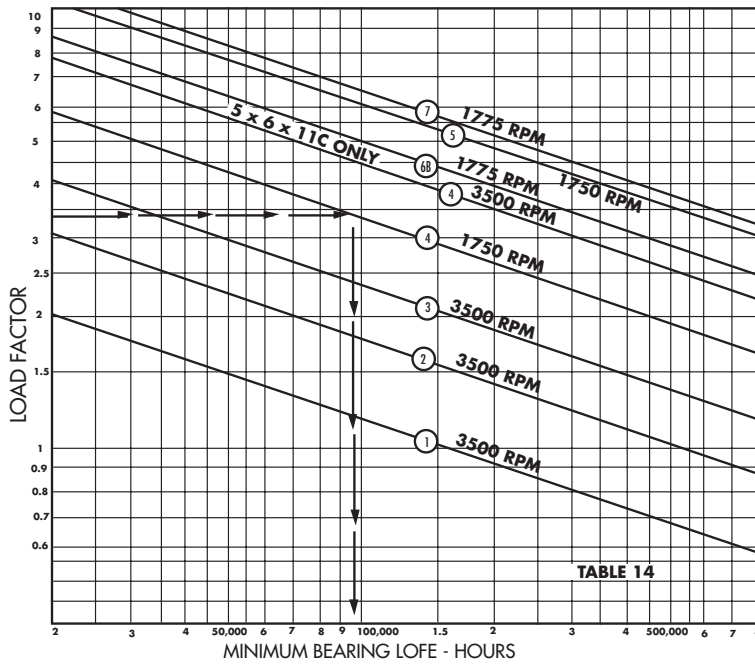

PUMP SIZE	POWER SERIES	PUMP SIZE FACTOR		
		1775 RPM	1175 RPM	885 RPM
10x12x12B	6B	4.50	5.00	
10x12x15B	6B	3.25	3.75	
10x12x15C	6B	3.50	4.75	
10x12x18	6B	3.25	3.75	
8x12x24	7	4.50		
12x14x15B	7	4.75	5.50	
12x14x18	7	4.00	4.50	
14x16x18	7		7.00	7.50

TABLE 11	CHART SPEED RPM	DESIRED SPEED RPM	MULTIPLY CHART LIFE BY
	3500	1750	2
	3500	1150	3
SPEED (R.P.M.) FACTORS	1750	1150	1.5
	1775	1175	1.5
	1775	875	2
	1175	875	1.3

EXAMPLE: A 5x6x15 pump operating at 1750 R.P.M. on a No. 4 power series with a shut-off head of 225 ft. T.D.H. has a Size Factor of 3.00, a Load Factor of 3.35, a maximum Shaft Deflection at the centerline of the impeller of .0092, and a minimum Bearing Life of 97,000 hours @ 1750 R.P.M.

# ENGINEERING DATA

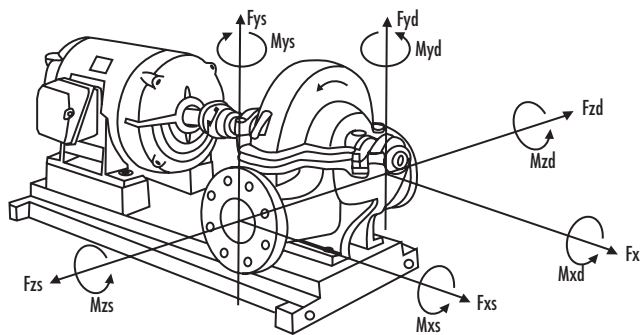

PUMP SIZE		FORCES-LBS.			MOMENTS-FT.LBS.		
		FX	FY	FZ	MX	MY	MZ
2x2-1/2x9	DISCHARGE	200	250	750	250	350	300
	SUCTION	200	250	750	250	350	300
2x2-1/2x10	DISCHARGE	200	250	750	250	350	300
	SUCTION	200	250	750	250	350	300
2x2-1/2x12	DISCHARGE	200	250	750	250	350	300
	SUCTION	200	200	750	250	350	300
2-1/2x3x10	DISCHARGE	500	550	1350	600	800	700
	SUCTION	450	550	1350	600	800	700
2-1/2x3x12	DISCHARGE	400	500	1350	600	800	700
	SUCTION	400	500	1350	600	800	700
3x4x10	DISCHARGE	450	550	1350	600	800	700
	SUCTION	400	500	1350	600	800	700
3x4x14	DISCHARGE	400	450	1400	600	800	700
	SUCTION	350	400	1400	600	800	700
4x5x10	DISCHARGE	450	550	1400	650	800	700
	SUCTION	400	500	1400	650	800	700
4x5x11	DISCHARGE	250	850	750	1200	550	1400
	SUCTION	250	850	750	1200	550	1400
4x5x15	DISCHARGE	700	850	2200	1200	1600	1450
	SUCTION	650	750	2200	1200	1600	1450
4x6x18	DISCHARGE	650	800	2200	1250	1600	1450
	SUCTION	550	700	2200	1250	1600	1450
5x6x11	DISCHARGE	800	400	2200	500	1600	600
	SUCTION	700	350	2200	500	1600	600
5x6x15	DISCHARGE	700	850	2200	1250	1600	1450
	SUCTION	600	750	2200	1250	1600	1450
5x6x17	DISCHARGE	650	800	2250	1250	1600	1500
	SUCTION	600	750	2250	1250	1600	1500
6x8x11	DISCHARGE	800	950	2200	1250	1600	1450
	SUCTION	650	750	2200	1250	1600	1450
6x8x11HH	DISCHARGE	1150	1300	3250	2100	2800	2550
	SUCTION	950	1100	3250	2100	2800	2550
8x8x11	DISCHARGE	750	750	2250	1000	1600	1200
	SUCTION	650	600	2250	1000	1600	1200

Values tabled are for forces and moments acting alone at the suction or discharge flange.

Combined forces and moments must be reduced so:

$$\frac{F_{xd}}{F_{xdmax}} + \frac{F_{yd}}{F_{ydmax}} + \frac{F_{zd}}{F_{zdmax}} + \frac{M_{xd}}{M_{xdmax}} + \frac{M_{yd}}{M_{ydmax}} + \frac{M_{zd}}{M_{zdmax}} + \frac{F_{xs}}{F_{xsmax}} + \frac{F_{ys}}{F_{ysmax}} + \frac{F_{zs}}{F_{zsmac}} + \frac{M_{xs}}{M_{xsmax}} + \frac{M_{ys}}{M_{ysmac}} + \frac{M_{zs}}{M_{zsmac}} \leq 1.0$$

# ENGINEERING DATA

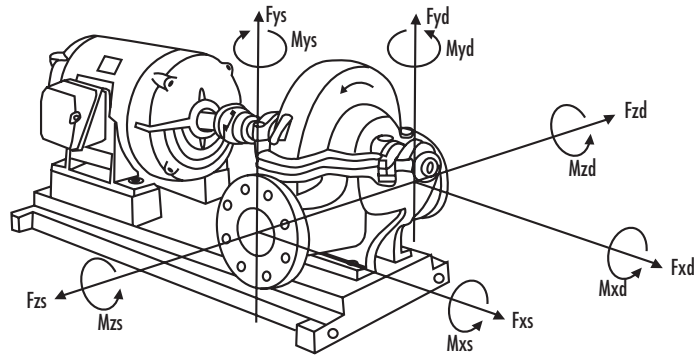

PUMP SIZE		FORCES-LBS.			MOMENTS-FT.LBS.		
		FX	FY	FZ	MX	MY	MZ
6x8x14HH	DISCHARGE	1150	1300	3250	2100	2800	2550
	SUCTION	950	1100	3250	2100	2800	2550
6x8x15	DISCHARGE	1150	1300	3250	2100	2800	2550
	SUCTION	950	1100	3250	2100	2800	2550
6x8x18	DISCHARGE	1000	1200	3300	2150	2850	2600
	SUCTION	900	1050	3300	2150	2850	2600
6x8x20	DISCHARGE	1050	1250	3300	2200	2850	2650
	SUCTION	900	1100	3300	2200	2850	2650
8x10x12	DISCHARGE	950	1150	3300	2150	2850	2600
	SUCTION	900	1100	3300	2150	2850	2600
8x10x15	DISCHARGE	950	1150	3300	2200	2850	2600
	SUCTION	900	1100	3300	2200	2850	2600
8x10x17	DISCHARGE	950	1150	3300	2200	2850	2650
	SUCTION	900	1100	3300	2200	2850	2650
8x10x21	DISCHARGE	1650	2000	3300	4000	4350	3350
	SUCTION	1400	1700	3350	4000	4350	3350
10x12x12B	DISCHARGE	1350	1700	3350	3000	4450	4650
	SUCTION	1150	1400	3350	3000	4450	4650
10x12x15B	DISCHARGE	1300	1600	3400	3050	4500	4700
	SUCTION	1100	1350	3400	3050	4500	4700
10x12x15C	DISCHARGE	1300	1600	3400	3050	4500	4700
	SUCTION	1100	1350	3400	3050	4500	4700
10x12x18	DISCHARGE	1200	1500	3400	3050	4500	4700
	SUCTION	1000	1250	3400	3050	4500	4700
10x12x18D	DISCHARGE	1200	1500	3400	3050	4500	4700
	SUCTION	1000	1250	3400	3250	4500	4700
8x12x24	DISCHARGE	1075	1325	3350	2625	3850	3675
	SUCTION	950	1175	3350	2625	3850	3675
12x14x15B	DISCHARGE	1300	1700	3450	3250	4600	5050
	SUCTION	1000	1300	3450	3250	4600	5050
12x14x18	DISCHARGE	1250	1650	3500	3300	4650	5100
	SUCTION	950	1250	3500	3300	4650	5100
14x16x18	DISCHARGE	1050	1450	3600	3550	4800	5500
	SUCTION	850	1150	3600	3550	4800	5500

Values tabled are for forces and moments acting alone at the suction or discharge flange. Combined forces and moments must be reduced so:

$$\frac{F_{xd}}{F_{xdmax}} + \frac{F_{yd}}{F_{ydmax}} + \frac{F_{zd}}{F_{zdmax}} + \frac{M_{xd}}{M_{xdmax}} + \frac{M_{yd}}{M_{ydmax}} + \frac{M_{zd}}{M_{zdmax}} + \frac{F_{xs}}{F_{xsmax}} + \frac{F_{ys}}{F_{ysmax}} + \frac{F_{zs}}{F_{zsmac}} + \frac{M_{xs}}{M_{xsmax}} + \frac{M_{ys}}{M_{ysmac}} + \frac{M_{zs}}{M_{zsmac}} \leq 1.0$$





**800 Airport Road | North Aurora, Illinois 60542 | Ph: 630.859.7000 | [pentair.com](http://pentair.com)**

All indicated Pentair trademarks and logos are property of Pentair. Third party registered and unregistered trademarks and logos are the property of their respective owners. Because we are continuously improving our products and services, Pentair reserves the right to change specifications without prior notice. Pentair is an equal opportunity employer.

©2021 Pentair. All Rights Reserved.

2018125141449-DT (06-30-2021)