



AURORA[®]

CIRCULATOR PUMP

INSTRUCTION AND INSTALLATION MANUAL

NOTE! To the installer: Please make sure you provide this manual to the owner of the equipment or to the responsible party who maintains the system.

CALIFORNIA PROPOSITION 65 WARNING:

▲ WARNING This product and related accessories contain chemicals known to the State of California to cause cancer, birth defects or other reproductive harm.

GENERAL. The life of your Aurora pump can be extended considerably by carefully following the installation instructions contained herein. Each step of the pump installation instructions plays a vital part in assuring long life, efficient operation, and reduced maintenance, from the initial location of the pump through prestarting directions.

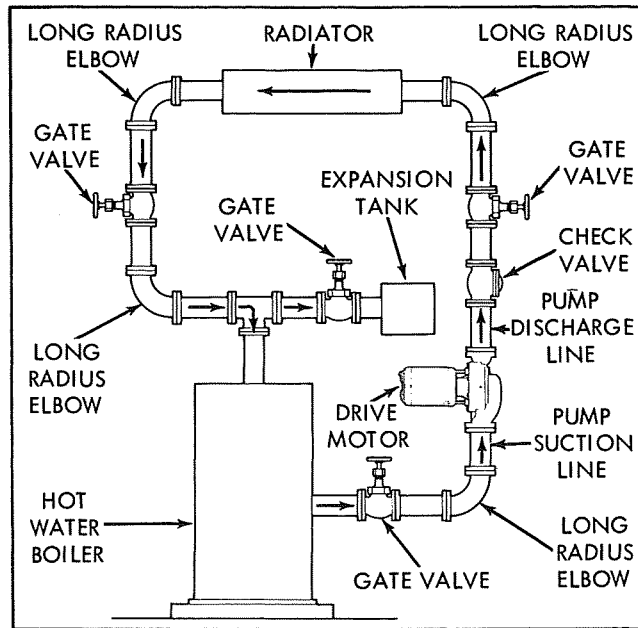

FIGURE 1. SIMPLIFIED HOT WATER CIRCULATING SYSTEM

UNPACKING YOUR PUMP. The crate containing your pump should be opened immediately upon receipt from the factory, and the pump generally inspected for damage and shortage of parts. Particular attention should be given to the discharge and suction nozzle threads or flanges. Any damage or shortage of parts should be reported to the carrier immediately.

CLEANING. If your pump is to be installed immediately, it will be necessary to remove the protective covers from all openings, and to clean the exposed metal parts thoroughly with white gasoline or other suitable solvent to remove the preservative coating.

STORAGE. If your pump is not to be put in service immediately it should be covered and stored in a clean dry area. The protective covers and preservative should be left intact until the pump is put into service. For extended storage, the pump should be

dried internally with hot air or some other suitable means, and once free of moisture, filled with a protective fluid such as light oil or kerosene. Accordingly, at time of installation, the pump will have to be completely dismantled and thoroughly cleaned.

PLANNING THE PUMP LOCATION. You probably have spent considerable time planning where your pump will be located. However you may have overlooked some factor which may affect pump operation or efficiency.

Your circulator pump has been designed for simple installation. The pump can be mounted with the suction and discharge nozzles in any position, as long as the motor remains in a horizontal plane with the oil cups up.

Wherever possible the pump should be located in a clean, open area, where it is easily accessible for inspection, lubrication and repair. Pumps installed in dark, dirty areas or in cramped locations are often neglected which can result in premature failure of both the pump and the driver.

Protect your pump against the possibility of flooding. Although water will not seriously damage the pump, the drive motor can be damaged.

The pump should be located in an area where moisture either from leakage through the packing or from condensation can be adequately drained off. Moisture dripping onto exposed metal or wood can cause rapid deterioration of the area. Also, wet floors produce safety hazards.

Adequate provisions should be made for electrical wiring to the pump motor. A switch and overload protection should be installed near the pump unless it is impractical. The electrical conduit should be positioned in such a way as to preclude the possibility of moisture entering the conduit or the motor and causing short circuits.

LEVELING THE PUMP. Circulator pumps are normally installed in line, that is suspended between the suction and discharge piping. Therefore it is necessary to have the suction and discharge piping level when the pump is installed. To level the pump, simply assemble the pump to either the suction or the discharge piping, and with a spirit level on the suction or discharge flange, level the pump in the vertical plane. This will automatically level the pump in the horizontal plane since the suction and discharge flanges are machined at right angles to the motor horizontal center line.

CIRCULATOR PUMP INSTALLATION

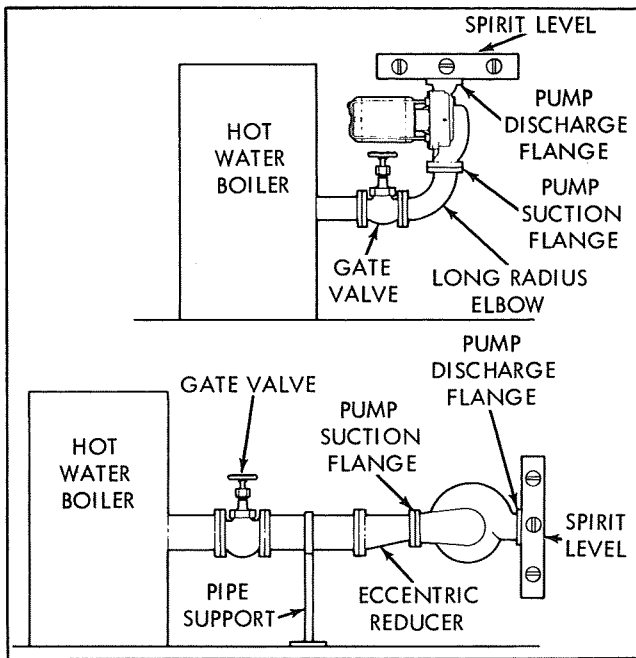

FIGURE 2. LEVELING THE PUMP

PIPING. Your pump unit is now ready to be piped. The piping practices you follow will directly affect the efficiency and power consumption of your pump. Pay particular attention to the seemingly insignificant details involved in piping your pump for they make the difference between a good and bad installation.

SUPPORTING THE PIPE. Both the suction and the discharge piping should be independently supported near the pump. Liberal use of pipe hangers and support blocks will prevent excessive strain on the pump casing and on the pipe joints.

SUCTION PIPING. The suction piping should be short, but no less than ten pipe diameters in length, and direct with as few elbows and fittings as possible to keep head loss, from friction, at a minimum.

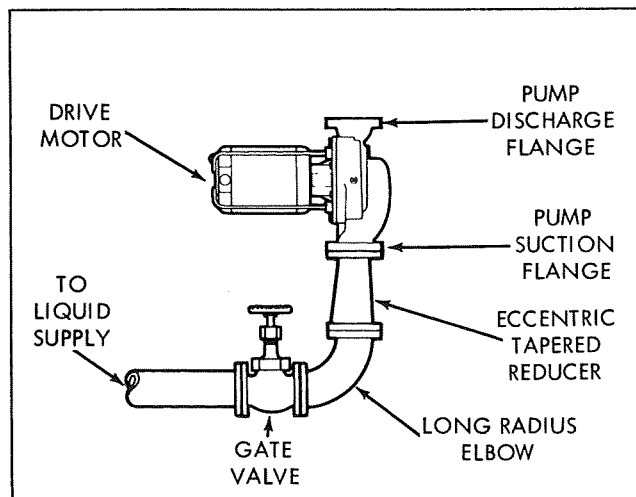

FIGURE 3. SUCTION PIPING FOR A CIRCULATOR PUMP

A horizontal suction line should have a gradual rise to the pump, and pass under any interfering piping.

PIPE. The suction pipe diameter should be at least the same diameter as the suction nozzle on the pump, and preferably larger. Use of a smaller diameter pipe will result in loss of head due to friction. All joints must be tight to maintain prime on the pump.

ELBOWS. Long radius elbows should be used in place of standard elbows wherever possible, because of their superior flow characteristics. For instance, head loss in a standard four inch elbow is equivalent to the head loss in a piece of pipe 11 feet long, while the head loss in a long radius elbow is approximately half as much. Elbows should not be used at the suction nozzle, but if it is unavoidable, they should be installed in a vertical position. Elbows installed in any position at the suction nozzle have a tendency to distribute the liquid unevenly in the impeller chamber, causing a reduction in capacity, and creating an undesirable thrust condition.

REDUCERS. Eccentric reducers should be installed directly at the suction nozzle, with the taper at the bottom to prevent air pockets from forming. Straight taper reducers should never be used in a horizontal suction line because of the air pocket that is formed at the leg of the reducer and the pipe.

DISCHARGE PIPE. Discharge piping should also be short and direct as possible, with few elbows and fittings, to reduce head loss from friction.

PIPE. The discharge pipe diameter should be the same as, or larger than, the discharge nozzle diameter. The size of discharge pipe to be used is dependent on its application.

The recommended pipe diameter can be obtained from your nearest Aurora Pump Sales Office.

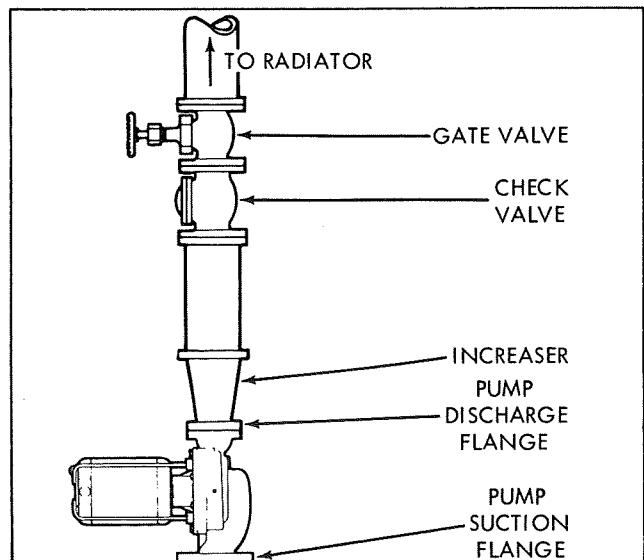

FIGURE 4. DISCHARGE PIPING FOR A CIRCULATOR PUMP

CIRCULATOR PUMP INSTALLATION

ELBOWS. Long radius elbows should be used in the discharge piping as well as in the suction piping to prevent excessive head loss due to friction.

Whenever possible, elbows should not be installed directly at the discharge nozzle as the turbulence created by the elbow will affect pressure gauge readings.

REDUCERS AND INCREASERS. An increaser should be installed at the discharge nozzle if larger diameter discharge piping is used. Straight taper increasers and/or reducers are satisfactory in discharge applications.

EXPANSION JOINTS. Expansion joints are used primarily to prevent the transmission of piping strain, caused by thermal expansion and contraction, piping misalignment, pressure changes, or other causes, to the pump casing. They also are used to suppress any noise that may be transmitted through the piping.

It is recommended that the flexible metal type of expansion joint be used because rubber expansion joints, while costing less, have a tendency to deteriorate, making frequent replacement necessary.

If an expansion joint must be used, an anchor or restraining device should be installed between the joint and the pump to prevent objectional forces from being transmitted to the pump. If an anchor is not installed at this point, a force equal to the area of the expansion joint times the pressure in the pipe is developed and transmitted to the pump. This force may exceed the allowable flange loading and could result in damage to the pump or piping.

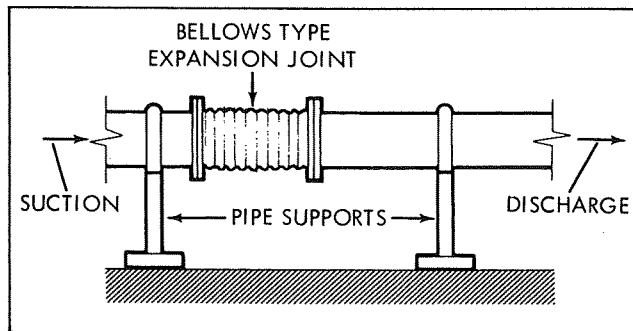

FIGURE 5. TYPICAL EXPANSION JOINT

PIPE ALIGNMENT. Proper piping alignment is essential before connection is made. Piping alignment should never be achieved by force, this could produce strain on the piping and the pump casing. Proper supports should be installed for the piping to keep its weight off the pump casing.

When flange bolts are used, line up the piping first, then loosely install flange bolts. Check the piping alignment, and tighten flange bolts until all bolts are tightened securely.

AIR IN PIPING. One of the most common conditions affecting pump efficiency is the formation of air pockets in the suction line. The air pockets are a

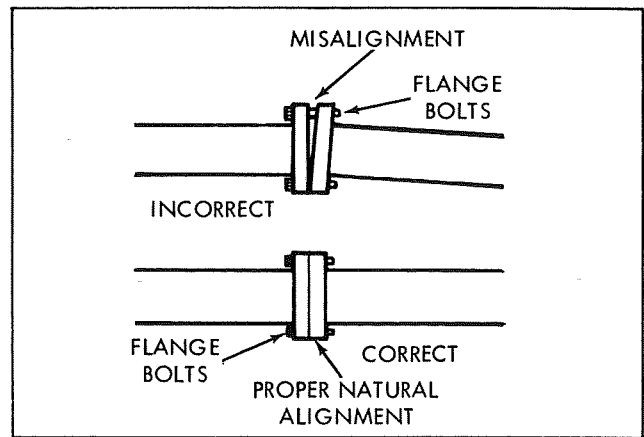

FIGURE 6. PIPE ALIGNMENT

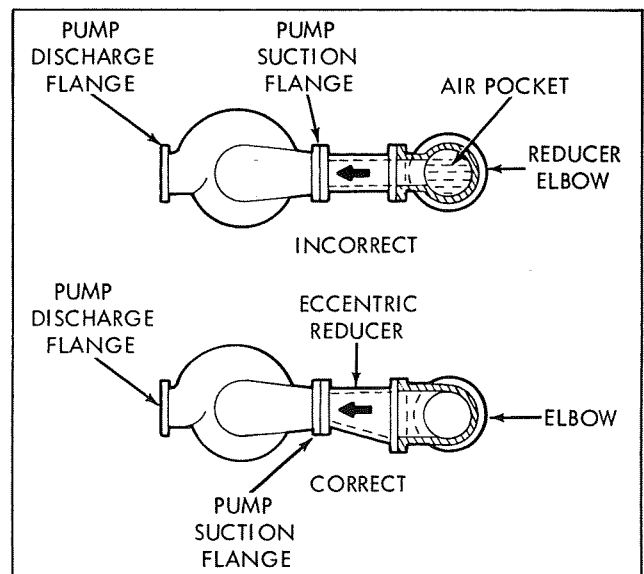

FIGURE 7. CORRECT AND INCORRECT INSTALLATION OF ELBOWS AND REDUCERS

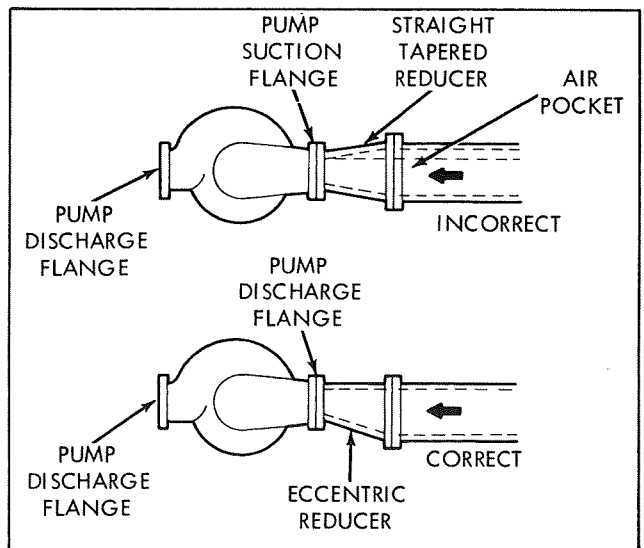

FIGURE 8. CORRECT AND INCORRECT TYPES OF REDUCERS

CIRCULATOR PUMP INSTALLATION

result of high points and improper installation of elbows, reducers, and valves in the suction piping.

For suction lift applications, lantern rings are required to prevent air from leaking into the pump, through the stuffing box, or at the joints.

The pump seals or packings depend on the liquid being pumped for lubrication. Excessive air can prevent proper lubrication with resultant damage to them.

VALVES. A circulator pump is normally installed as part of a closed system. As a result, once the pump has been primed a flooded suction condition exists.

SUCTION LIFT. A gate valve should be installed in the suction piping to enable shutting off the liquid to the pump for inspection and maintenance. The gate valve in the suction line should be installed with the stem in a horizontal or downward position to prevent formation of an air pocket at the top of the valve.

DISCHARGE VALVES. The discharge piping should include both a check valve and a gate valve. The check valve should be located between the gate valve and the pump. The check valve protects against a reverse flow of liquid if the driver fails. The gate valve is used as a throttling valve to control pump volume, and to shut down the pump for inspection and maintenance.

AIR VENT VALVE. Vent valves are installed at the high points in the pump casing to allow air or vapor to escape. These valves are used to release trapped air from the pump casing during priming and when pump becomes air bound.

FLOODED SUCTION PRIMING. This method of priming a pump is relatively simple. The liquid source is located above the pump, and all that is necessary to prime the pump is to open the air vent valve, or plug in the pump casing, and to crack the gate valve in the suction line. The suction line and pump should be filled slowly until a steady stream of liquid is observed flowing from the air vent. After your pump is operating, it is recommended that the air vent valve or plug be opened again to insure that all air has been expelled from the pump casing.

On suction lift applications, it is necessary to completely fill the suction piping and the pump casing

with the liquid to be pumped. This can be accomplished by removing the air vent valve or plug in the pump casing, and inserting a pipe nipple in the orifice, with an appropriate increaser to accommodate a hose connection. A priming line can also be inserted in a discharge piping between the check valve and the pump or the priming can be done with a bucket and funnel. The important thing is to completely fill the suction pipe and pump casing with liquid.

When the pump is started, the vacuum created by pumping the priming liquid, combined with atmospheric pressure in the liquid well, forces liquid into the suction piping, thus maintaining a constant flow of liquid through the pump.

ELECTRICAL WIRING. Normally, your pump will be supplied with an attached drive motor. The motor should be wired in accordance with the wiring diagram found on the motor name plate. Be sure the voltage, frequency, and phase of your power supply corresponds with the name plate data. It is advisable to provide a separate switch and overload protection for your pump motor to protect against power failure in some other area. Conversely, if the pump motor develops electrical problems, it will be isolated from other equipment.

PRESTARTING INSTRUCTION. Before starting the pump, check the direction of rotation. Make sure that the rotation is the same as the arrow on the casing, or as otherwise indicated. This can be done by momentarily connecting the electrical leads to the pump motor and watching the motor shaft.

CAUTION

Do not operate the pump without liquid. Pump seals and packings depend on the liquid being pumped for lubrication.

Be sure the pump is primed and that no air exists in the suction pipe and pump casing.

Make sure the suction piping gate valve is open. The gate valve in the discharge piping should be closed, as a centrifugal pump operating against a closed valve consumes less power than it does when the valve is open. When the motor has reached operating speed, the discharge gate valve should be opened.

THIS PAGE INTENTIONALLY LEFT BLANK

THIS PAGE INTENTIONALLY LEFT BLANK

WARRANTY

Seller warrants equipment (and its component parts) of its own manufacture against defects in materials and workmanship under normal use and service for one (1) year from the date of installation or start-up, or for eighteen (18) months after the date of shipment, whichever occurs first. Seller does not warrant accessories or components that are not manufactured by Seller; however, to the extent possible, Seller agrees to assign to Buyer its rights under the original manufacturer's warranty, without recourse to Seller. Buyer must give Seller notice in writing of any alleged defect covered by this warranty (together with all identifying details, including the serial number, the type of equipment, and the date of purchase) within thirty (30) days of the discovery of such defect during the warranty period. No claim made more than 30 days after the expiration of the warranty period shall be valid. Guarantees of performance and warranties are based on the use of original equipment manufactured (OEM) replacement parts. Seller assumes no responsibility or liability if alterations, non-authorized design modifications and/or non-OEM replacement parts are incorporated. If requested by Seller, any equipment (or its component parts) must be promptly returned to Seller prior to any attempted repair, or sent to an authorized service station designated by Seller, and Buyer shall prepay all shipping expenses. Seller shall not be liable for any loss or damage to goods in transit, nor will any warranty claim be valid unless the returned goods are received intact and undamaged as a result of shipment. Repaired or replaced material returned to customer will be shipped F.O.B., Seller's factory. Seller will not give Buyer credit for parts or equipment returned to Seller, and will not accept delivery of any such parts or equipment, unless Buyer has obtained Seller's approval in writing. The warranty extends to repaired or replaced parts of Seller's manufacture for ninety (90) days or for the remainder of the original warranty period applicable to the equipment or parts being repaired or replaced, whichever is greater. This warranty applies to the repaired or replaced part and is not extended to the product or any other component of the product being repaired. Repair parts of its own manufacture sold after the original warranty period are warranted for a period of one (1) year from shipment against defects in materials and workmanship under normal use and service. This warranty applies to the replacement part only and is not extended to the product or any other component of the product being repaired. Seller may substitute new equipment or improve part(s) of any equipment judged defective without further liability. All repairs or services performed by Seller, which are not covered by this warranty, will be charged in accordance with Seller's standard prices then in effect.

THIS WARRANTY IS THE SOLE WARRANTY OF SELLER AND SELLER HEREBY EXPRESSLY DISCLAIMS AND BUYER WAIVES ALL OTHER WARRANTIES EXPRESSED, IMPLIED IN LAW OR IMPLIED IN FACT, INCLUDING ANY WARRANTIES OF MERCHANTABILITY OR FITNESS FOR A PARTICULAR PURPOSE. Seller's sole obligation under this warranty shall be, at its option, to repair or replace any equipment (or its component parts) which has a defect covered by this warranty, or to refund the purchase price of such equipment or part. Under the terms of this warranty, Seller shall not be liable for (a) consequential, collateral, special or liquidated losses or damages; (b) equipment conditions caused by normal wear and tear, abnormal conditions of use, accident, neglect, or misuse of said equipment; (c) the expense of, and loss or damage caused by, repairs or alterations made by anyone other than the Seller; (d) damage caused by abrasive materials, chemicals, scale deposits, corrosion, lightning, improper voltage, mishandling, or other similar conditions; (e) any loss, damage, or expense relating to or resulting from installation, removal or reinstallation of equipment; (f) any labor costs or charges incurred in repairing or replacing defective equipment or parts, including the cost of reinstalling parts that are repaired or replaced by Seller; (g) any expense of shipment of equipment or repaired or replacement parts; or (h) any other loss, damage or expense of any nature.

The above warranty shall not apply to any equipment which may be separately covered by any alternate or special warranties.

PERFORMANCE: In the absence of Certified Pump Performance Tests, equipment performance is not warranted or guaranteed. Performance curves and other information submitted to Buyer are approximate and no warranty or guarantee shall be deemed to arise as a result of such submittal. All testing shall be done in accordance with Seller's standard policy under Hydraulic Institute procedures.

LIABILITY LIMITATIONS: Under no circumstances shall the Seller have any liability under the Order or otherwise for liquidated damages or for collateral, consequential or special damages or for loss of profits, or for actual losses or for loss of production or progress of construction, regardless of the cause of such damages or losses. In any event, Seller's aggregate total liability under the Order or otherwise shall not exceed the contract price.

ACTS OF GOD: Seller shall in no event be liable for delays in delivery of the equipment or other failures to perform caused by fires, acts of God, strikes, labor difficulties, acts of governmental or military authorities, delays in transportation or procuring materials, or causes of any kind beyond Seller's control.

COMPLIANCE WITH LAW: Seller agrees to comply with all United States laws and regulations applicable to the manufacturing of the subject equipment. Such compliance shall include: The Fair Labor Standards Acts of 1938, as amended; Equal Employment Opportunity clauses of Executive Order 11246, as amended; Occupational Safety and Health Act of 1970 and the standards promulgated thereunder, if applicable. Since compliance with the various Federal, State, and Local laws and regulations concerning occupational health and safety, pollution or local codes are affected by the use, installation and operation of the equipment and other matters over which Seller has no control, Seller assumes no responsibility for compliance with those laws and regulations, whether by way of indemnity, warranty, or otherwise. It is incumbent upon the Buyer to specify equipment which complies with local codes and ordinances.



AURORA®

800 Airport Road
North Aurora, Illinois 60542
630-859-7000
www.aurorapump.com