



**AURORA<sup>®</sup>**

# **TURBINE PUMP**

## **INSTRUCTION AND OPERATION MANUAL**

NOTE! To the installer: Please make sure you provide this manual to the owner of the equipment or to the responsible party who maintains the system.

**CALIFORNIA PROPOSITION 65 WARNING:**

**Warning:** This product and related accessories contain chemicals known to the State of California to cause cancer, birth defects or other reproductive harm.

**TURBINE PUMP OPERATION.** Turbine pumps operate under an extremely wide range of conditions. The pump you have selected exactly fits your specific requirements. Before putting your pump into operation, however, there are certain basic ground rules that have to be followed to assure maximum efficiency, long pump life, and maintenance free service.

Turbine pumps should never be started or run dry. Operating a pump dry can cause burning of the packings or seal, resulting in destruction of the packings or seals, and possible scoring of the pump shaft. To prevent the pump from being run dry, it is necessary to prime it before starting it.

A turbine pump should not be throttled, or the volume controlled on the suction side of the pump. Throttling the pump on the suction side not only reduces the capacity, but also reduces pump efficiency, and more important, can cause serious damage to pump due to cavitation. Cavitation occurs when the pressure at any point inside the pump drops below the vapor pressure of the liquid. The liquid flashes and forms vapor bubbles. These bubbles move along with the liquid into a higher pressure area, where the bubbles collapse or implode creating an area of low pressure. The implosion phenomenon is characterized by a crackling noise and sometimes by loud knocking as the vapor bubbles are collapsed. Repetition of this action causes a wearing away of the metal on the impeller and other parts of the pump, and if allowed to continue can result in serious damage to the pump.

The turbine pump capacity can be effectively controlled by use of a throttling valve in the discharge piping. If it is necessary to throttle or limit the discharge of a turbine pump, however, it may be necessary to provide relief valves and by-pass piping to accommodate the excessive pressures that may be developed within the pump and to reduce h.p. requirements.

A turbine pump should not be operated with the gate valve in the discharge line closed. Unlike centrifugal pumps, which use a minimum amount of power when the throttling valve is closed, a turbine pump requires maximum power at shut-off.

On pumps equipped with packings, there should be sufficient leakage to insure lubrication of the packing and effective cooling of the stuffing box. The packing gland should always be adjusted evenly and not too tightly. Over-tightening the packing can generate heat that will burn the packing and cause scoring of the shaft, making it necessary to replace both the shaft and the packings.

A strainer or sediment trap should be provided on the suction side of the pump to prevent introduction of abrasive particles into the turbine blades. These particles can cause excessive wear of the blade and the channel rings, making it necessary to replace either the impeller or the rings.

Adequate precautions should be taken to prevent freezing of the liquid in the pump when the pump is not in operation. If there is any possibility of freezing, the water should be drained off by removal of the plugs provided in the pump casing.

All mounting bolts and piping connections must be firmly tightened to prevent excessive vibration, leakage, and possible damage to the pump. The mounting bolts are particularly important. If they are not firmly tightened, the base plate upon which the pump is mounted may deflect, causing a misalignment of the pump and the driver.

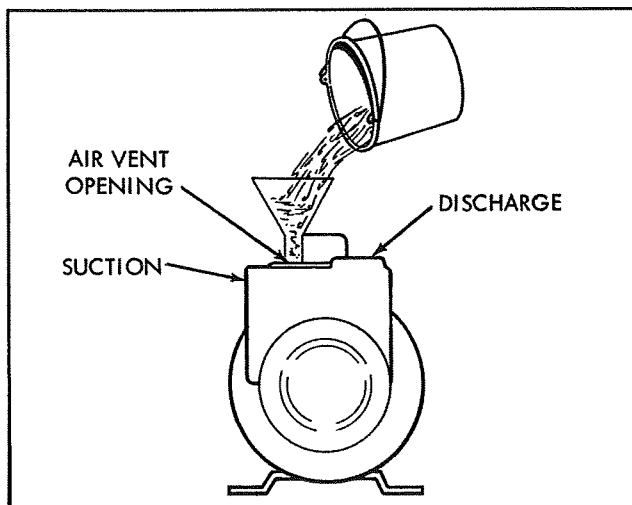

FIGURE 1. PRIMING BY HAND

**STARTING THE PUMP.** In order to start your pump, it is first necessary to prime it.

**PRIMING THE PUMP.** Your pump will not operate satisfactorily until it is primed. All air must be expelled from the suction piping and pump casing, and replaced by the liquid to be pumped. There are several methods of priming pumps. The one you select will depend on your specific requirements.

**FLOODED SUCTION PRIMING.** This method of priming a pump is relatively simple. The liquid source is located above the pump, and all that is necessary to prime the pump is to open the air vent

## TURBINE PUMP OPERATION

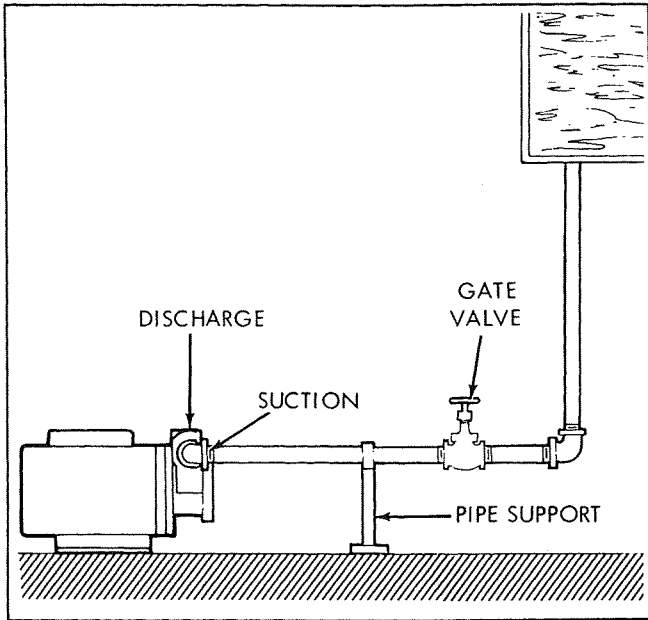

FIGURE 2. FLOODED SUCTION PRIMING

valve or plug in the pump casing, and to crack the gate valve in the suction line. The suction line and pump should be filled slowly until a steady stream of liquid is observed flowing from the air vent. After your pump is operating, it is recommended that the air vent valve or plug be opened again to insure that all air has been expelled from the pump casing.

**FOOT VALVE PRIMING.** A foot valve can be used for priming on suction lift applications. The foot valve located at the bottom end or foot of the suction piping, functions as a check valve which allows flow in one direction only, toward the pump.

Initial priming is accomplished by completely filling the suction piping and pump casing with the liquid to

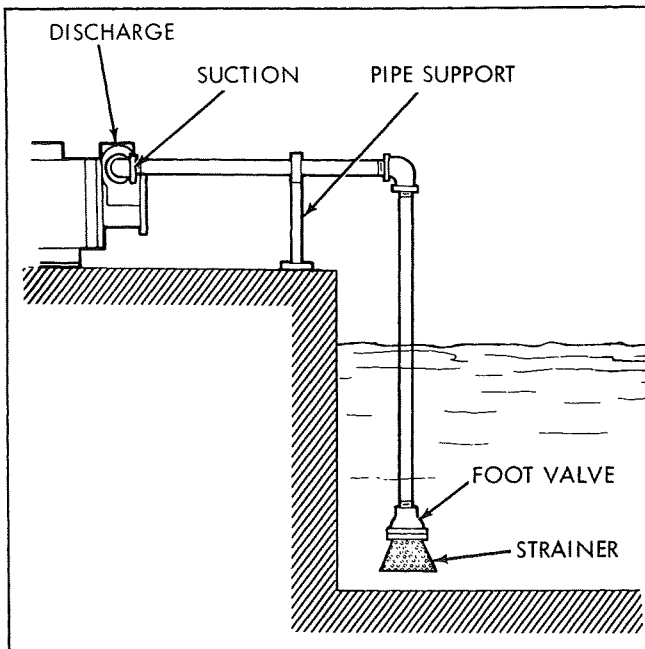

FIGURE 3. PRIMING WITH FOOT VALVE

be pumped. This can be done by removing the air vent valve or plug at the top of the pump casing, and inserting a pipe nipple in the orifice with an appropriate increaser to accommodate a hose connection. A priming line can also be inserted in the discharge piping between the check valve and the pump, or the priming can be done with a bucket and funnel. The important thing is to completely fill the suction pipe and pump casing with liquid.

When the pump is started, the vacuum created by pumping the priming fluid, combined with atmospheric pressure in the liquid well, forces liquid into the suction piping, thus opening the valve and keeping it open until the pump is shut down. When the pump is shut down, the liquid being pumped reverses its flow causing the valve to close. The liquid is now trapped in the suction piping and pump casing, thus maintaining a prime on the pump.

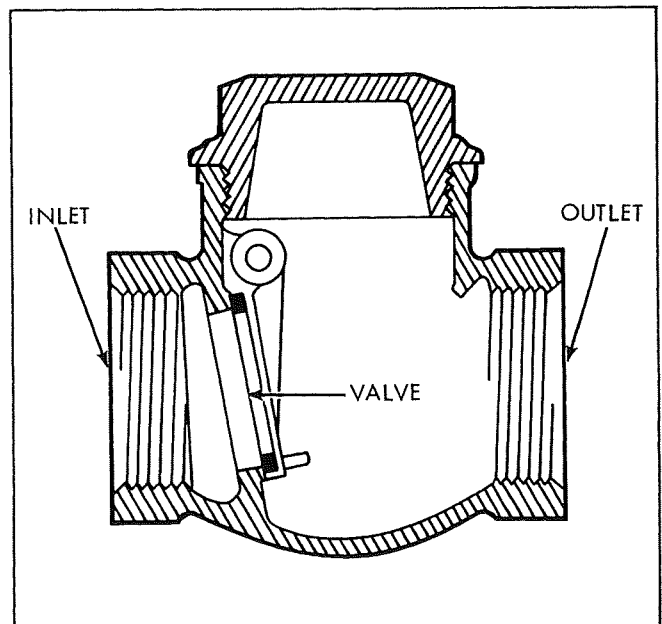

FIGURE 4. FOOT VALVE CUTAWAY VIEW

**VACUUM PRIMING.** Vacuum priming consists of removing air from the pump casing and suction piping, and drawing liquid into them by means of a vacuum creating device. The types of vacuum equipment range from a simple hand pump to complex central priming systems. Your specific priming requirements will govern what type of vacuum primer you use.

**AIR EJECTOR.** One type of vacuum primer is the air ejector. If liquid under pressure or steam is available, an ejector can be used. The ejector is connected to the air vent orifice. A stream of the ejecting medium is passed through the ejector creating a vacuum in the ejector. This action will draw air from the pump casing and suction piping. When liquid flows steadily from the ejector discharge pipe, the pump is primed.

**VACUUM PUMPS.** Rotary or reciprocating pumps are frequently used as vacuum pumps. They fall into two categories, wet-vacuum and dry-vacuum.

## TURBINE PUMP OPERATION

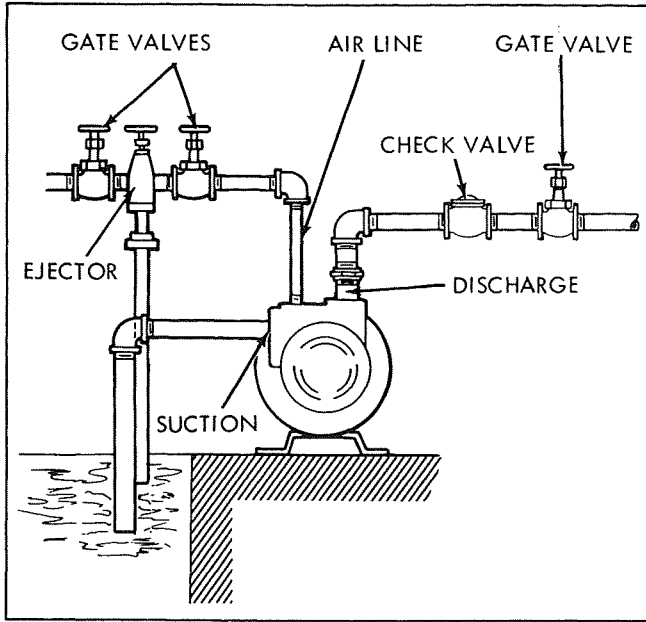

FIGURE 5. PRIMING BY EJECTOR

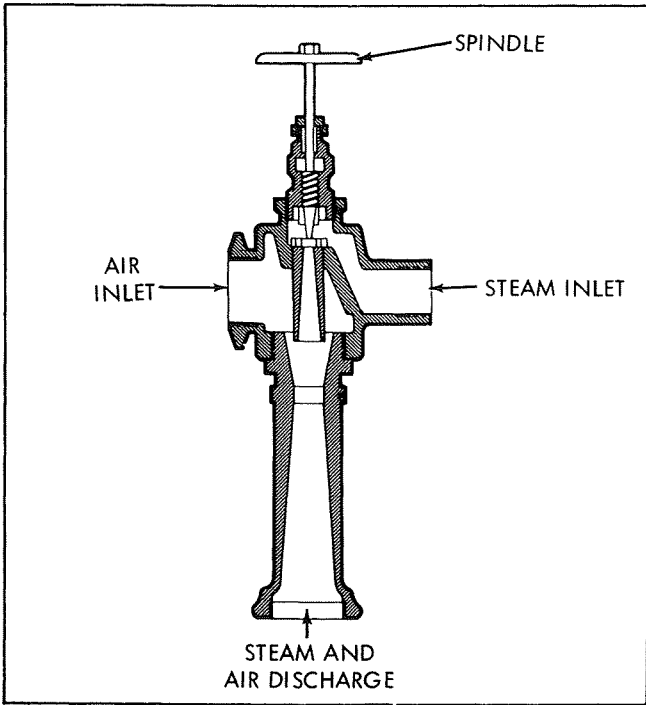

FIGURE 6. EJECTOR CUTAWAY VIEW

The principle of operation is essentially the same, however, the dry-vacuum pump cannot accommodate a liquid and air mixture, while the wet-vacuum pump can accommodate liquid, air or a combination of both.

Vacuum pumps can be installed as part of a central priming system servicing many pumps, as an automatic priming system, or as a manually controlled independently driven pump.

The suction piping of the vacuum pump is connected to the air vent orifice on the pump to be primed. The vacuum produced by the vacuum pump removes air from the turbine pump suction piping and casing, and

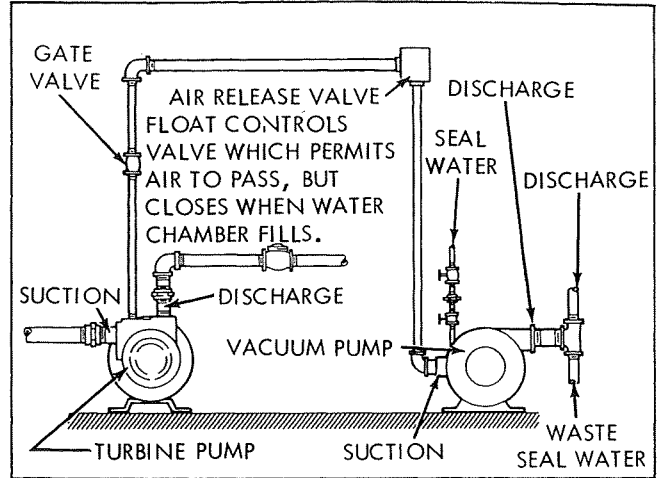

FIGURE 7. VACUUM PUMP PRIMING

draws liquid from the liquid well into the turbine pump. Dry-vacuum pumps must be installed so that no liquid is taken into the air pump. Installation of a water trap, or use of a vacuum tank are recommended for dry vacuum pumps.

**INDUCTOR PRIMING.** On suction lift applications it may be desirable to prime your pump with a priming inductor. This type of primer is comprised of a liquid nozzle and an inductor at the foot end of the suction piping. The nozzle and inductor are con-

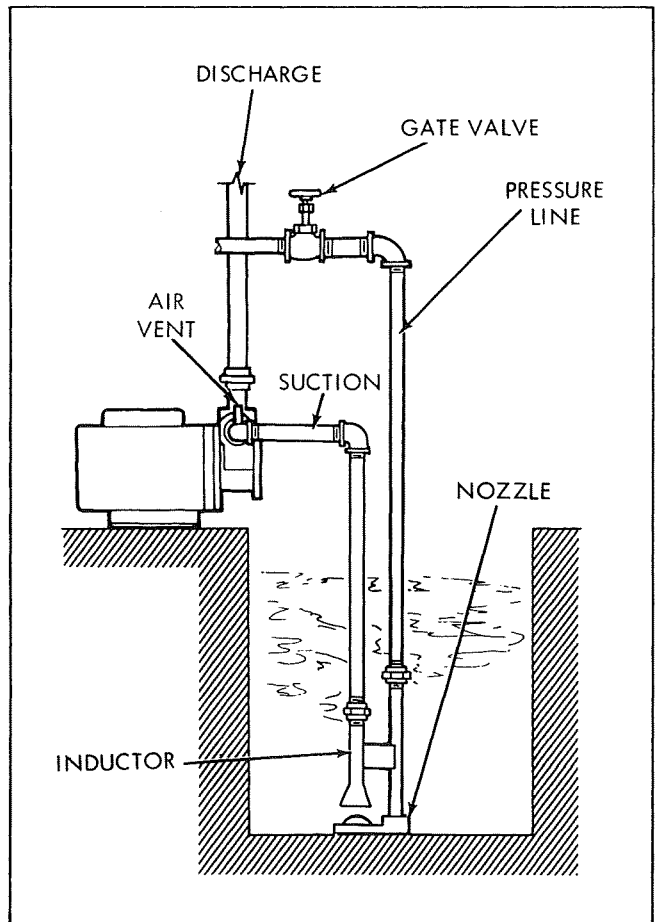

FIGURE 8. INDUCTOR PRIMING

## TURBINE PUMP OPERATION

nected to a high pressure liquid supply such as a city water service.

The pump is primed by opening the valve in the pressure line. This will allow the liquid to flow through the nozzle and into the inductor. The velocity of the high pressure liquid drives the liquid into the suction piping and to the pump, thus completing the priming operation.

**POSITION OF DISCHARGE GATE VALVE WHEN STARTING.** The discharge gate valve should be open when a turbine pump is started, because a turbine pump primed and operating at full speed, develops a very high internal pressure when the discharge gate valve is closed.

**POSITION OF SUCTION PIPING GATE VALVE.** In flooded suction applications, the gate valve is opened at the time the pump is being primed, and will re-

main open for starting and operation. If a flooded suction condition does not exist and a gate valve has been installed in the suction line, the operator may close the gate valve as the pump is shut off. However, the pump should not be run with the suction closed for more than a few seconds. In this manner the pump will maintain its prime for short periods of time. It is recommended that either a foot valve or a check valve be installed in the suction piping, if it is necessary for the pump to maintain its prime while it is shut down.

**COOLANT VALVES.** Valves in the cooling liquid line should be opened prior to the pump's being started, and will remain open while the pump is in operation.

**SHUTTING DOWN THE PUMP.** To shut down your pump, simply shut off the motor and close the applicable valves.

**THIS PAGE INTENTIONALLY LEFT BLANK**

**THIS PAGE INTENTIONALLY LEFT BLANK**

## WARRANTY

Seller warrants equipment (and its component parts) of its own manufacture against defects in materials and workmanship under normal use and service for one (1) year from the date of installation or start-up, or for eighteen (18) months after the date of shipment, whichever occurs first. Seller does not warrant accessories or components that are not manufactured by Seller; however, to the extent possible, Seller agrees to assign to Buyer its rights under the original manufacturer's warranty, without recourse to Seller. Buyer must give Seller notice in writing of any alleged defect covered by this warranty (together with all identifying details, including the serial number, the type of equipment, and the date of purchase) within thirty (30) days of the discovery of such defect during the warranty period. No claim made more than 30 days after the expiration of the warranty period shall be valid. Guarantees of performance and warranties are based on the use of original equipment manufactured (OEM) replacement parts. Seller assumes no responsibility or liability if alterations, non-authorized design modifications and/or non-OEM replacement parts are incorporated. If requested by Seller, any equipment (or its component parts) must be promptly returned to Seller prior to any attempted repair, or sent to an authorized service station designated by Seller, and Buyer shall prepay all shipping expenses. Seller shall not be liable for any loss or damage to goods in transit, nor will any warranty claim be valid unless the returned goods are received intact and undamaged as a result of shipment. Repaired or replaced material returned to customer will be shipped F.O.B., Seller's factory. Seller will not give Buyer credit for parts or equipment returned to Seller, and will not accept delivery of any such parts or equipment, unless Buyer has obtained Seller's approval in writing. The warranty extends to repaired or replaced parts of Seller's manufacture for ninety (90) days or for the remainder of the original warranty period applicable to the equipment or parts being repaired or replaced, whichever is greater. This warranty applies to the repaired or replaced part and is not extended to the product or any other component of the product being repaired. Repair parts of its own manufacture sold after the original warranty period are warranted for a period of one (1) year from shipment against defects in materials and workmanship under normal use and service. This warranty applies to the replacement part only and is not extended to the product or any other component of the product being repaired. Seller may substitute new equipment or improve part(s) of any equipment judged defective without further liability. All repairs or services performed by Seller, which are not covered by this warranty, will be charged in accordance with Seller's standard prices then in effect.

THIS WARRANTY IS THE SOLE WARRANTY OF SELLER AND SELLER HEREBY EXPRESSLY DISCLAIMS AND BUYER WAIVES ALL OTHER WARRANTIES EXPRESSED, IMPLIED IN LAW OR IMPLIED IN FACT, INCLUDING ANY WARRANTIES OF MERCHANTABILITY OR FITNESS FOR A PARTICULAR PURPOSE. Seller's sole obligation under this warranty shall be, at its option, to repair or replace any equipment (or its component parts) which has a defect covered by this warranty, or to refund the purchase price of such equipment or part. Under the terms of this warranty, Seller shall not be liable for (a) consequential, collateral, special or liquidated losses or damages; (b) equipment conditions caused by normal wear and tear, abnormal conditions of use, accident, neglect, or misuse of said equipment; (c) the expense of, and loss or damage caused by, repairs or alterations made by anyone other than the Seller; (d) damage caused by abrasive materials, chemicals, scale deposits, corrosion, lightning, improper voltage, mishandling, or other similar conditions; (e) any loss, damage, or expense relating to or resulting from installation, removal or reinstallation of equipment; (f) any labor costs or charges incurred in repairing or replacing defective equipment or parts, including the cost of reinstalling parts that are repaired or replaced by Seller; (g) any expense of shipment of equipment or repaired or replacement parts; or (h) any other loss, damage or expense of any nature.

The above warranty shall not apply to any equipment which may be separately covered by any alternate or special warranties.

**PERFORMANCE:** In the absence of Certified Pump Performance Tests, equipment performance is not warranted or guaranteed. Performance curves and other information submitted to Buyer are approximate and no warranty or guarantee shall be deemed to arise as a result of such submittal. All testing shall be done in accordance with Seller's standard policy under Hydraulic Institute procedures.

**LIABILITY LIMITATIONS:** Under no circumstances shall the Seller have any liability under the Order or otherwise for liquidated damages or for collateral, consequential or special damages or for loss of profits, or for actual losses or for loss of production or progress of construction, regardless of the cause of such damages or losses. In any event, Seller's aggregate total liability under the Order or otherwise shall not exceed the contract price.

**ACTS OF GOD:** Seller shall in no event be liable for delays in delivery of the equipment or other failures to perform caused by fires, acts of God, strikes, labor difficulties, acts of governmental or military authorities, delays in transportation or procuring materials, or causes of any kind beyond Seller's control.

**COMPLIANCE WITH LAW:** Seller agrees to comply with all United States laws and regulations applicable to the manufacturing of the subject equipment. Such compliance shall include: The Fair Labor Standards Acts of 1938, as amended; Equal Employment Opportunity clauses of Executive Order 11246, as amended; Occupational Safety and Health Act of 1970 and the standards promulgated thereunder, if applicable. Since compliance with the various Federal, State, and Local laws and regulations concerning occupational health and safety, pollution or local codes are affected by the use, installation and operation of the equipment and other matters over which Seller has no control, Seller assumes no responsibility for compliance with those laws and regulations, whether by way of indemnity, warranty, or otherwise. It is incumbent upon the Buyer to specify equipment which complies with local codes and ordinances.



**AURORA®**

800 Airport Road  
North Aurora, Illinois 60542  
630-859-7000  
[www.aurorapump.com](http://www.aurorapump.com)