



# VERTICAL MULTISTAGE PUMPS PVM(X) SERIES



## INSTALLATION AND OPERATION MANUAL

[pentair.com](http://pentair.com)

# TABLE OF CONTENTS

---

Safety Instructions.....	3
General Information.....	4
Installation.....	5
Operation.....	7
Troubleshooting.....	12
Repair Parts.....	13
Pump Dimensions.....	19
Warranty.....	47

# SAFETY INSTRUCTIONS

## IMPORTANT SAFETY INSTRUCTIONS

SAVE THESE INSTRUCTIONS - This manual contains important instructions that should be followed during installation, operation and maintenance of the product. Save this manual for future reference.

**⚠** This is the safety alert symbol. When you see this symbol on your pump or in this manual, look for one of the following signal words and be alert to the potential for personal injury!

**⚠ DANGER** indicates a hazard which, if not avoided, will result in death or serious injury.

**⚠ WARNING** indicates a hazard which, if not avoided, could result in death or serious injury.

**⚠ CAUTION** indicates a hazard which, if not avoided, could result in minor or moderate injury.

NOTICE addresses practices not related to personal injury.

To avoid serious or fatal personal injury and possible property damage, carefully read and follow the safety instructions.

- ◆ Install pump according to all code requirements.
- ◆ Compare pump nameplate data with desired operating range.
- ◆ Pump only liquids compatible with pump component materials (that is, liquids that will not attack the pump).
- ◆ Make sure plumbing is adequate to handle system pressure.
- ◆ Periodically perform maintenance inspection on pump and system components.
- ◆ Wear safety glasses at all times when working on pumps.

## CALIFORNIA PROPOSITION 65 WARNING

**⚠ WARNING** This product and related accessories contain chemicals known to the State of California to cause cancer, birth defects or other reproductive harm.

## INSPECT THE SHIPMENT

The vertical multistage centrifugal inline pump has been carefully inspected and packaged to assure safe delivery. Inspect the pump and fittings and report to the carrier any items which are damaged or missing.

## CONFIRM THAT YOU HAVE THE RIGHT PUMP:

### PVMX3 – 15 1.25" FLG EPDM

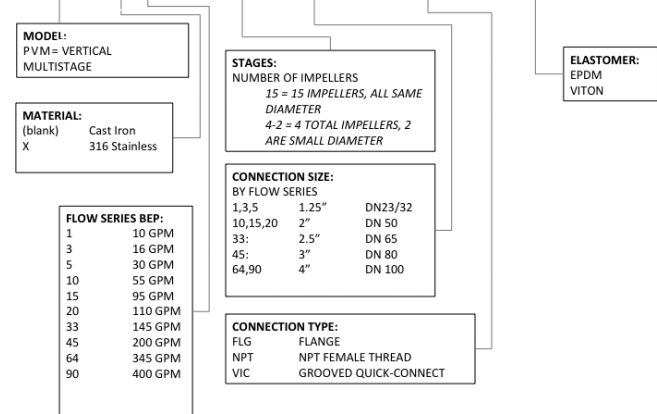

Figure 1 - Model Plate Information

Record the following information from the motor and pump nameplates for future reference:

Pump Model No.	
Bill of Material No.	
Motor Model No.	
Motor Serial No.	
HP	Volts/Hz/Ph
Rated Amp Draw	

NOTE! To the installer: Please make sure you provide this manual to the owner of the equipment or to the responsible party who maintains the system.

# GENERAL INFORMATION

---

## APPLICATIONS AND OPERATING RANGES

Aurora® multistage inline centrifugal pumps are designed for liquid transfer, circulation, and pressure boosting of hot or cold clean water or other thin, non-explosive liquids, not containing solid particles or fibers, which will not chemically attack the pump materials.

Typical applications include:

- ◆ Municipal water supply and pressure boosting
- ◆ Boiler feed and condensate systems
- ◆ Cooling water systems
- ◆ Irrigation
- ◆ Fire fighting

Maximum Ambient Temperature.....104° F(40° C)

Liquid Temperature Range.....5° F to 248° F (-15° C to +120° C)

Maximum Permissible Operating Pressure

Flow Series 1 through 20 . 360 psi

Flow Series 33 through 90 . 435 psi

Maximum operating pressure = Inlet pressure + maximum pump differential head

Electrical Data:.....See Motor Nameplate

Dimensions and Port-to-Port

Lengths. See pages 20-53 Record the following information

# INSTALLATION

**⚠ WARNING** Risk of electric shock. Can shock, burn or kill. Ground pump motor correctly before connecting to power supply, per article 250-80 of the National Electrical Code (NEC) in the U.S., or the Canadian Electrical Code (CEC), as applicable.

## LOCATION

Locate pump in a dry, well ventilated area, not subject to freezing or extreme variations in temperature.

Mount pump a minimum of 6" from any obstruction or hot surface. Install the pump with the motor shaft vertical. Make sure that an adequate supply of cool air reaches the motor cooling fan. Maximum ambient air temperature is 104° F (40° C).

For open systems requiring suction lift, locate the pump as close to the water source as possible.

## FOUNDATION

Foundation should be concrete or a similarly rigid foundation to provide a secure, stable mounting base for the pump.

Secure pump to foundation using all bolt holes. Refer to pages 20-47 for bolt plate dimensions. Be sure that all four pads on the base are properly supported. Shim pump base to make sure that pump is level.

## PIPING

**⚠ WARNING** Risk of explosion and scalding. Do not run pump with discharge valve closed; the water in the pump may boil, with risk of explosion and steam burns to anyone near.

If there is any danger of the pump running against a closed discharge valve, install a pressure relief or by-pass valve in the discharge pipe to allow for minimum liquid flow through the pump. Minimum liquid flow through the pump is needed for cooling and lubrication of the pump (Table I). Run the bypass/relief valve and discharge pipe to a floor drain or a tank for collection.

Suction pipe should be adequately sized (see Table II) and run as straight and as short as possible to keep friction losses to a minimum. Pipes, valves and fittings must have a pressure rating equal to or greater than the maximum system pressure.

Pressure check the discharge piping as required by codes or local regulations.

"Inlet" and "Outlet" are marked on the pump base to show the direction of the liquid flow through the pump.

Install anti-vibration mountings on either side of the pump if a minimum noise level is desired.

Install isolation valves in both inlet and outlet pipes near the pump (Figure 2). This allows for removal of pump for service without draining the system and isolation of the pump in case of a flooded suction condition.

Flow Series	Minimum Pumping Rate
PVM(X)1	1.0 GPM
PVM(X)3	1.5 GPM
PVM(X)5	3.0 GPM
PVM(X)10	5.5 GPM
PVM(X)15	9.5 GPM
PVM(X)20	11 GPM
PVM(X)33	35 GPM
PVM(X)45	40 GPM
PVM(X)64	45 GPM
PVM(X)90	45 GPM

Table I - Minimum Pumping Rates

Flow Series	Minimum Nominal Suction Pipe Size
PVM(X)1	
PVM(X)3	1.25 inches
PVM(X)5	
PVM(X)10	
PVM(X)15	1.5 inches
PVM(X)20	
PVM(X)33	2.5 inches
PVM(X)45	3 inches
PVM(X)64	
PVM(X)90	4 inches

Table II - Minimum Suction Pipe Sizes

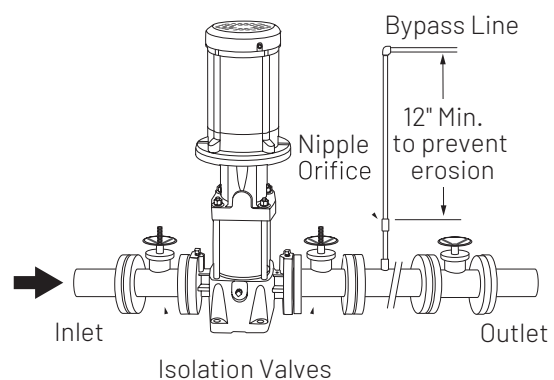

Figure 2 - Bypass required if pump might operate with discharge valve closed. See Table I for minimum required flow through pump to prevent overheating and to ensure lubrication.

# INSTALLATION

If the system pressure is greater than the pump's maximum inlet pressure the limits of the pump can be exceeded if the discharge pressure backs up to the inlet side of the pump. Installation of a check valve in the discharge pipe is recommended to prevent this condition.

Make sure, especially on the inlet side of the pump, that there are no airlocks in the system. See Figure 3 for correct pipe work to avoid airlocks. The suction pipe should be level or slightly rising.

Support all piping independently of the pump so the weight of the piping system does not strain the pump case. Make sure that the expansion and contraction of the piping system from temperature variations cannot put a strain on the pump.

If the system or pump must be drained periodically (especially if the discharge pipe is horizontal or slopes downward away from the pump), install a loop and vacuum valve as shown in Figure 4 to protect the pump against running dry. The highest point of the loop should be at least as high as the lowest point of the motor. This loop/valve combination will allow the pump and the system to be drained independently of one another.

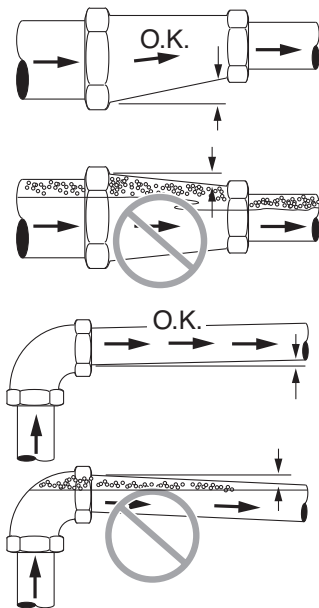

Figure 3 - Install Pipe Correctly to Prevent Air Locks

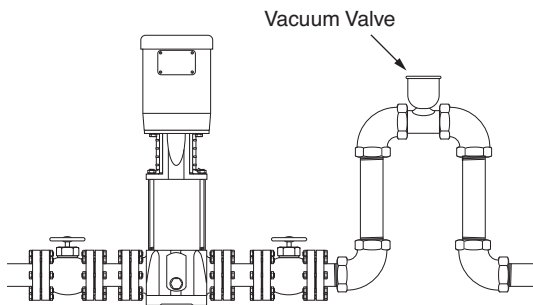

Figure 4 - Loop and Vacuum Valve Installation

## ELECTRICAL

Risk of electric shock. Can shock, burn or kill. All electrical work should be performed by a qualified electrician in accordance with the National Electrical Code and all local codes and regulations. Make sure that the motor voltage, phase and frequency match the incoming electrical supply. The proper operating voltage and other electrical information can be found on the motor nameplate. These motors are designed to run up to  $\pm 10\%$  of the nameplate-rated voltage. The wiring connection diagram can be found on either a plate attached to the motor or on a diagram inside the terminal box cover.

- ◆ If voltage variations are greater than  $\pm 10\%$  do not operate the pump.
- ◆ Incorrect voltage can cause fire or serious damage to the motor and voids warranty.
- ◆ Ground the pump motor correctly before connecting it to the power supply.
- ◆ Follow the wiring instructions when connecting the motor to the power lines.

## POSITION OF TERMINAL BOX

To turn the motor so that the terminal box faces the right direction, proceed as follows:

1. Disconnect the power to the pump motor.
2. Remove the coupling guards (use a screwdriver).
3. Remove the couplings.
4. Remove the bolts that fasten the motor to the pump.
5. Turn the motor to the required position (in quarter-turn increments).
6. Follow Steps 10-18 under Motor Replacement.

## FIELD WIRING

All wiring connections and wiring sizes must meet National Electrical Code and local requirements.

## MOTOR PROTECTION

See the motor nameplate for electrical connection/wiring diagram.

Aurora pumps must be used with the proper size and type of motor starter to ensure protection against damage from low voltage, phase failure, current imbalances, and overloads. The overload should be sized to trip at the full-load current rating of the motor.

# OPERATION

## PRIMING

**▲WARNING** Risk of explosion and scalding. Do not run the pump with the discharge valve closed; the water in the pump may boil, causing risk of explosion and steam burns to anyone nearby.

**▲WARNING** Risk of electric shock. Can shock, burn or kill. Disconnect all power to the pump before servicing or working on the pump. Make sure that the power is locked out and that the pump cannot be accidentally started.

Operation of closed systems or open systems with the liquid level above the pump priming plug:

1. Close the discharge isolating valve and loosen the needle valve located in the assembly in the pump head (Figure 5). Do not remove the needle valve.

**▲CAUTION** Risk of flooding. Can cause personal injury and/or property damage. Watch the direction of the priming plug and make sure that the liquid escaping from it does not injure persons nearby or damage the motor or other components. In hot water installations, pay particular attention to the risk of injury from scalding hot water.

2. Slowly open the isolation valve in the suction pipe until a steady stream of liquid runs out the vent in the priming port.
3. Tighten needle valve to 25 inch-pounds. Completely open isolation valves.

Please turn to Starting before proceeding any further.

## OPERATION OF OPEN SYSTEMS WITH THE LIQUID LEVEL BELOW THE TOP OF THE PUMP:

The suction pipe requires a check valve or isolation valve.

- ◆ Close the discharge isolation valve.
- ◆ Remove the vented priming plug.
- ◆ Pour liquid through the priming port until the suction pipe and the pump are completely filled with liquid.
- ◆ Replace the vented priming plug and tighten it securely.
- ◆ Repeat Steps 1-4 until the pump is primed.

Please turn to Starting before proceeding any further.

## CHECKING DIRECTION OF ROTATION

Do not disconnect the motor from the shaft to check the direction of rotation. If you remove the coupling, then you must adjust the shaft position when you reinstall it. This must be done before starting the pump.

Arrows on the pump head show the correct direction of rotation. When seen from the motor fan, the pump should rotate counterclockwise. For pump motors without a fan remove one of the coupling guards and look at the coupling to determine the direction of rotation. Turn off the pump and replace coupling guard.

Do not check the direction of rotation until the pump has been filled with liquid. See Priming, at left and above.

1. Switch power OFF.
2. Remove the coupling guard and rotate the pump shaft to be certain it can turn freely. Replace the coupling guard.
3. Verify that the electrical connections are in accordance with the wiring diagram on the motor.
4. If the fan is visible, turn on and off to verify rotation.
5. To reverse the direction of rotation, first switch OFF the power supply.
6. On three-phase motors, switch 2 of the 3 power leads on the load side of the starter. On single-phase motors, see the connection diagram on the motor nameplate. Change the wiring as indicated.

**▲WARNING** Risk of electric shock. Can shock, burn or kill. Ground the pump motor correctly before connecting to power supply per article 250-80 of National Electrical Code (NEC) in the U.S., or the Canadian Electrical Code (CEC), as applicable.

7. Switch on the power supply and recheck the direction of motor rotation.

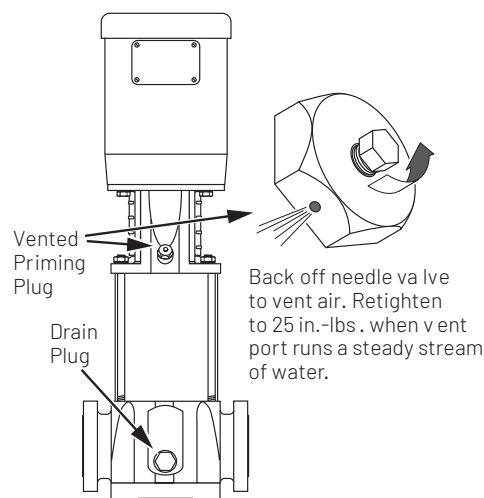

Figure 5 - Priming and Drain Plugs

# OPERATION

## STARTING

1. If a suction line isolation valve has been installed, check to be sure that it is completely opened.
2. For initial starting, the isolation valve in the discharge pipe should be almost closed.
3. Start the pump.
4. When the piping system has been filled with liquid, slowly open the discharge isolation valve until it is completely open. Opening the valve too fast may result in water hammer in the discharge pipe.

If the pump or system start to rattle, the pump is cavitating; to avoid damage to the pump, reduce the flow through the discharge isolation valve until the rattling stops. If this does not give adequate flow for your installation, call your installer or system designer.

5. Record the voltage and amperage of the motor. Adjust the motor overloads if required.
6. If pressure gauges have been installed, check and record operating pressures.
7. Check all controls for proper operation.

## MOTOR BEARINGS

For the greasing schedule and greasing procedure of the motor bearings follow the motor manufacturers recommendations.

## MAINTENANCE

### MOTOR REPLACEMENT

The reference numbers [shown as (11) or (88)] refer to the exploded views (Figures 10-13). See the appropriate exploded view for your model series.

Risk of electric shock. Can shock, burn or kill. Disconnect all power to the pump before servicing or working on pump. Make sure that power is locked out and that pump cannot be accidentally started.

1. Disconnect the power to the pump motor.
2. Close the nearest suction and discharge valves.
3. Remove the coupling guards (54).
4. Remove the socket head screws (73) and the coupling halves (44) from the shaft (81). See Figure 6.  
**NOTICE:** Socket head screws are metric. See Table III for specific metric driver sizes.
5. If your pump has a shaft pin (72), remove it.
6. Remove the motor bolts (74/92) and flatwashers that hold the motor and the motor stool (36/53) together.
7. Pull the old motor up and off of the motor bracket. **NOTICE:** Make a note of the orientation of the conduit box on the motor.
8. Thoroughly clean the surfaces of the mounting flanges on the new motor and the pump end.

9. Install the new motor on the pump with the conduit box in the desired position.
10. Lubricate the motor bolts (74/92) with oil.
11. Reinstall the flatwashers and motor bolts (74/92) that hold the motor and the motor stool (36/53) together, then tighten the bolts evenly and diagonally. See Table III for torque specifications.
12. PVM(X)1-PVM(X)20: Reinstall the shaft pin (72) if your pump has one. Raise the height of the pump shaft by using the shaft pin (72) as a lift point (you may have to put a block under the pin and lift with a flat screwdriver). Insert the stack height adjustment tool (see Figure 7) in below the shaft collar and let the shaft collar rest on it.

PVM(X)33-PVM(X)90: Pick up the shaft (if necessary, temporarily reinstall the coupling to provide a grip to lift by) and insert the stack height adjustment tool (see Figure 7) below the shaft collar. Let the shaft collar rest on it.

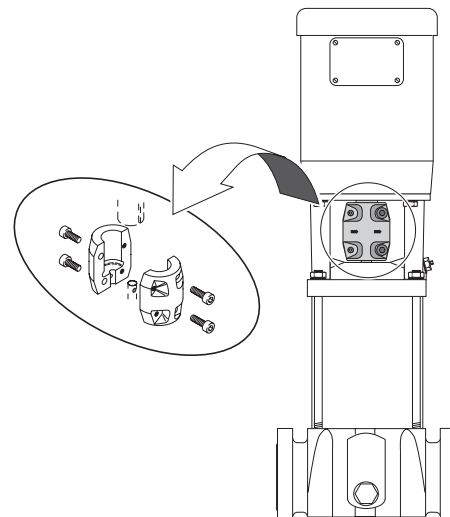

Figure 6 - Remove the Socket Head Screws and the Coupling Halves

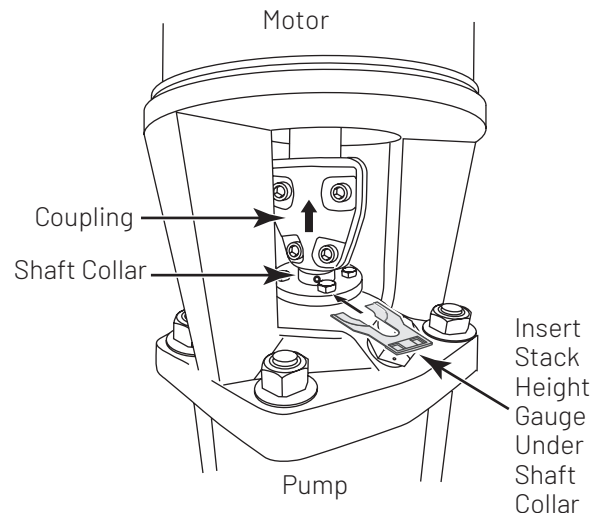

Figure 7 - Using the stack height adjusting tool

## OPERATION

13. Reinstall the coupling (43) on the pump and motor shaft. If the pump has a shaft pin, the pin axially locates the pump shaft. If the pump does not have a shaft pin, then set the coupling so that it grips equal lengths of the pump and motor shaft.
14. Tighten the coupling's socket head cap screws (73). **Note:** Torque settings are critical to prevent coupling movement. If the coupling is not tightened to the correct torque, it could slip on the shaft and overheat and damage both the coupling and the shaft. Refer to Table III, for torque specifications. Be sure to tighten the two halves of the coupling evenly (Figure 8).
15. Remove the stack height adjustment tool and clip it to one of the coupling guards.
16. Rotate the shaft to make sure that there is no interference. After assembly there should be a small gap between the shaft collar and the bracket. If anything rubs, repeat Steps 13, 14 and 15 to readjust pump shaft height.
17. Reinstall the coupling guards.
18. **NOTICE:** The guards should be in place before the unit is run.
19. Open the suction and discharge valves. Turn the power back on.

### REPLACING MECHANICAL SEAL

1. Follow Steps 1-7 under Motor Replacement and then proceed with Step 2 below.
2. Loosen the three set screws in the shaft collar above the mechanical seal and remove the shaft collar.
3. Remove the four retaining bolts (69) that hold down the seal flange and seal.
4. Use a flat screwdriver to pry up the seal flange. Remove the top portion of the seal.
5. Using the three round holes on the top of the shaft sleeve, or notch in flange (Figure 9), remove the remaining portions of the seal.
6. Clean the seal seat area with a wetted cloth. **NOTICE:** Be sure that you do not scratch, chip, or scar the seal face. Be sure that the seal face is clean before finishing assembly.
7. Wipe a small amount of water onto the O-ring on the inside of the new seal.
8. Slide the new seal assembly onto the shaft as a single unit.
9. Install the four retaining bolts in the seal flange and tighten them to 3.0 foot-lbs. (4.0 Nm).
10. Follow Steps 8 through 19 under Motor Replacement to reinstall the motor.

### REPLACING PUMP STACK

The reference numbers [shown as (11) or (88)] refer to the exploded view (Figures 10-13). See the appropriate exploded view for your model series.

1. Follow Steps 1-7 under Motor Replacement, then proceed with Step 2 below.
2. Remove the motor bracket adapter plate (50), if your pump has one.
3. Follow Steps 2-5 under Mechanical Seal Replacement and then proceed with Step 3 below.
4. Remove the staybolt nuts (77) and flatwashers (78) from the staybolts (81). Use vice-grips, if necessary, to prevent the staybolts from unscrewing out of the pump base.  
**NOTICE:** It is not necessary to remove the staybolts when replacing the stack.
5. With the base firmly attached to a solid floor, pull the motor stool (36) or motor stool/pump head assembly (36/53 or 36/56) straight up off the staybolts.
6. Make a note of the orientation of any tabs in the top of the stack assembly, then remove the stack assembly by pulling it straight up.
7. Install the new stack assembly, making sure that the orientation of the tabs matches the orientation of the tabs on the old stack assembly.
8. Replace the stack sleeve O-ring (82) located in the motor stool (36/53) or pump head (36/56). Make sure that the new O-ring is evenly seated in the O-ring groove in the motor

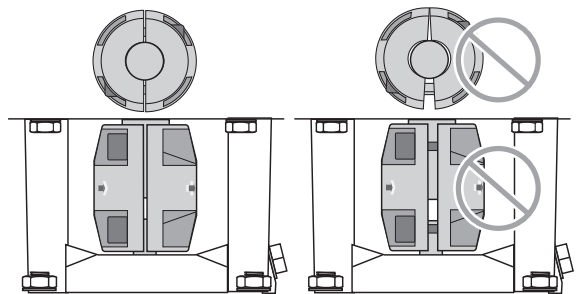

Figure 8 - Make Sure that the coupling halves are evenly tightened

9. Apply water to the stack sleeve O-ring in the motor stool/pump head (82) and to the top of the stack sleeve (48).
10. **PVM1-PVM20:** Slide the motor stool (36) over the staybolts (81) and onto the sleeve (48). Slide the pump head (36) over the staybolts onto the stack sleeve (48). Be sure the stack sleeve O-ring seats in the pump head. Add the staybolt nuts and washers (77,78) and tighten them to torque specifications listed in Table III.

# OPERATION

**PVM(X)1-20:** Mount the pump head (56) on the stack sleeve (48). Be sure the stack sleeve O-ring (82) seats in the groove in the pump head. Follow it with the motor stool (36) which goes over the staybolts (81) and seats on the pump head. Slide the pump head (36) over the staybolts onto the stack sleeve (48). Be sure the stack sleeve O-ring seats in the pump head. Add the staybolt nuts and washers (77,78) and tighten them to torque specifications listed in Table III.

**PVM(X)33, PVM(X)45-PVM(X)90:** Slide the pump head (36) over the staybolts onto the stack sleeve (48). Be sure the stack sleeve O-ring seats in the pump head. Add the staybolt nuts and washers (77,78) and tighten them to torque specifications listed in Table III. Place the motor stool (53) on the pump head and fasten it with four pump head bolts (74A). Tighten the pump head bolts to torque specifications given in Table III.

11. Make sure that the stack can rotate freely.
12. Follow Steps 6-10 under Mechanical Seal Replacement.
13. Follow Steps 11-19 under Motor Replacement to reinstall the motor.

**⚠ WARNING** Risk of explosion and scalding. Do not run pump with discharge valve closed; the water in the pump may boil, causing risk of explosion and steam burns to anyone nearby.

### FREQUENCY OF STARTS AND STOPS

Check pump cycling frequency and make sure that the pump starts per hour do not exceed the motor manufacturer's specification.

### FROST PROTECTION

1. If you do not use your pump during seasons of frost, drain it and add a glycol based antifreeze (50/50 mixture) to avoid damage.

**⚠ CAUTION** Risk of flooding. Can cause personal injury and/or property damage. Watch the direction of the priming plug and make sure that liquid escaping from it does not injure persons nearby or damage the motor or other components. In hot water installations, pay particular attention to the risk of injury from scalding hot water.

2. Upon restart dispose of spent antifreeze properly.
3. Do not replace the drain plug or tighten the priming plug until you put the pump back in service again.

### REGULAR MAINTENANCE CHECKS

The following checks should be made at regular intervals:

1. The pump meets required performance and is operating smoothly and quietly.
2. There are no leaks.
3. The motor is not overheating.
4. Remove and clean all strainers and filters in the system.
5. Verify amp draw – check motor amperage.
6. Pump wear rings and shaft require no regular maintenance.

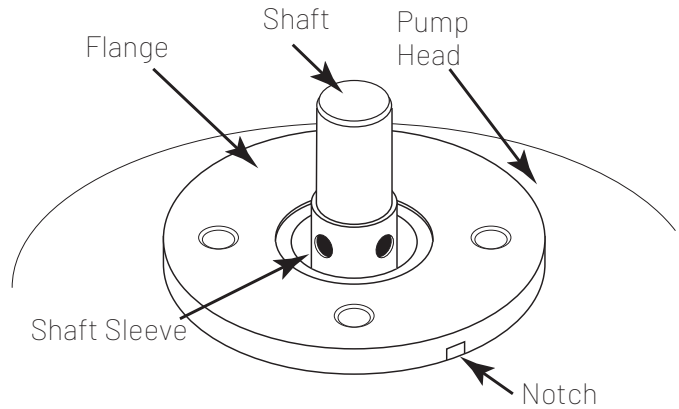

Figure 9

# TROUBLESHOOTING

Risk of electrical shock and possible unexpected starts. Disconnect all power to the pump before servicing or working on pump. Make sure that power is locked out and that pump cannot be accidentally started.

Problem	Cause
1. Motor does not run when started	<ul style="list-style-type: none"> <li>A. Power failure</li> <li>B. Fuses blown</li> <li>C. Motor starter overload has tripped out</li> <li>D. Main contacts in motor starter are not making contact or the coil is faulty</li> <li>E. Control circuit fuses or breaker are defective</li> <li>F. Motor is defective</li> </ul>
2. Motor starter overload trips out immediately when power supply is switched on	<ul style="list-style-type: none"> <li>A. One fuse has blown</li> <li>B. Contacts in motor overload relay are faulty</li> <li>C. Cable connections are loose or faulty</li> <li>D. Motor winding is defective</li> <li>E. Pump mechanically blocked</li> <li>F. Overload setting is too low</li> </ul>
3. Motor starter overload trips out occasionally	<ul style="list-style-type: none"> <li>A. Overload setting is too low</li> <li>B. Low voltage or high voltage at peak times</li> </ul>
4. Motor starter has not tripped out but the motor does not run	<ul style="list-style-type: none"> <li>A. Check 1 A), B), D) and E)</li> </ul>
5. Pump capacity is not constant	<ul style="list-style-type: none"> <li>A. Pump inlet pressure is too low</li> <li>B. Suction pipe/pump partly blocked</li> <li>C. Pump is sucking air</li> </ul>
6. Pump runs but gives no water	<ul style="list-style-type: none"> <li>A. Suction pipe/pump blocked</li> <li>B. Foot or non-return valve is blocked in closed position</li> <li>C. Leakage in suction pipe</li> <li>D. Air in suction pipe or pump</li> <li>E. Motor rotates in the wrong direction</li> </ul>
7. Pump runs backwards when switched off	<ul style="list-style-type: none"> <li>A. Leakage in suction pipe</li> <li>B. Foot or non-return valve is defective</li> <li>C. Foot valve is blocked in open or partly open position</li> <li>D. Non return valve leaks or is blocked in open or partly open position</li> <li>E. Discharge valve is defective</li> </ul>
8. Leakage from shaft seal	<ul style="list-style-type: none"> <li>A. Pump shaft position is incorrect</li> <li>B. Shaft seal is defective</li> </ul>
9. Noise	<ul style="list-style-type: none"> <li>A. Cavitation is occurring in the pump</li> <li>B. Pump does not rotate freely (That is, there is increased frictional resistance) because of incorrect shaft position</li> </ul>

## OPERATION

Description	Type of Fastener	Item No.	Size	Torque (Nm)	Torque (ft-lbs)	Flow Series
Shaft Collar Set Screw	Set Screw	none	M5	2.5	1.8	All
Mech Seal Holder Screws	Socket Head Cap Screw	69	M6	4.0	3.0	All
Couplings Bolts	Socket Head Cap Screw	73	M6	13.0	9.6	Varies
			M8	31.0	45.7	Varies
			M10	62.0	25.8	Varies
Pipe Plug	Hex Head	76	M16	35.0	25.8	All
Exhaust Screw	Hex Head	64	M6	35.0	25.8	All
Drain Plug	Hex Head	63	M16	35.0	25.8	All
Motor Bolts	Hex Head	74	3/8-16 x 1"	40.7	30.0	Varies
			1/2-13 x 1.25"	47.5	35.0	Varies
			1/2-13 x 1.50"	47.5	35.0	Varies
			1/2-13 x 1.75"	47.5	35.0	Varies
Pump Head/Stool Bolts	Socket Head Cap Screw	74	M10	62.0	45.7	PVM10, PVM90
			M12	40.0	29.5	PVM1-PVM5
Staybolt Nut		77	M16	80.0	59.0	PVM10-PVM20
			M16	110.0	81.1	PVM33, PVM150
Shaft Locknut	Hex Nut	40	M8	18.0	13.3	PVM1-PVM20
		88	M14	31.0	22.9	PVM33-PVM90
Strap Bolt		70	M8	15.0	11.1	PVM10-PVM90
Collet Locknut		22	M30	100.0	73.8	PVM33-PVM90

Table III - Torque Specifications (foot-lbs.) For Cast Iron and Stainless Steel Models



## REPAIR PARTS

Component	PVM1, PVM3	PVMX1, PVMX3	PVM5	PVMX5
11	Discharge	Discharge	Discharge	Discharge
12	Diffuser, Normal	Diffuser, Normal	Diffuser, Normal	Diffuser, Normal
13	Diffuser, with Bearing	Diffuser, with Bearing	Diffuser, with Bearing	Diffuser, with Bearing
14	Bearing	Bearing	Bearing	Bearing
18	Impeller	Impeller	Impeller	Impeller
27	Clamp	Clamp	Clamp	Clamp
28	Diffuser, Bottom	Diffuser, Bottom	Diffuser, Bottom	Diffuser, Bottom
36	Motor Stool	Motor Stool	Motor Stool	Motor Stool
37	Shaft	Shaft	Shaft	Shaft
38	Stack Washer	Stack Washer	Stack Washer	Stack Washer
39	Bushing	Bushing	Bushing	Bushing
40	Bolt, Shaft	Bolt, Shaft	Bolt, Shaft	Bolt, Shaft
42	Spacer	Spacer	Spacer	Spacer
42A	Spacer	Spacer	Spacer	Spacer
42B	Spacer	Spacer	Spacer	Spacer
42C	Spacer	Spacer	Spacer	Spacer
54	Coupling Guard	Coupling Guard	Coupling Guard	Coupling Guard
56	n/a	Pump Head	n/a	Pump Head
57	Mechanical Seal Assembly	Mechanical Seal Assembly	Mechanical Seal Assembly	Mechanical Seal Assembly
59	Base	Base	Base	Base
61	n/a	Connecting Flange	n/a	Connecting Flange
62	n/a	Base Plate	n/a	Base Plate
63	Drain Plug	Drain Plug	Drain Plug	Drain Plug
64	Vent Plug	Vent Plug	Vent Plug	Vent Plug
65	Pump Head Plug	Pump Head Plug	Pump Head Plug	Pump Head Plug
69	Screw, Mechanical Seal	Screw, Mechanical Seal	Screw, Mechanical Seal	Screw, Mechanical Seal
72	Shaft Pin	Shaft Pin	Shaft Pin	Shaft Pin
73	Bolt, Coupling	Bolt, Coupling	Bolt, Coupling	Bolt, Coupling
74	Bolt, Motor	Bolt, Motor	Bolt, Motor	Bolt, Motor
75	Screw, Coupling Guard	Screw, Coupling Guard	Screw, Coupling Guard	Screw, Coupling Guard
76	O-ring, Vent & Drain Plug	O-ring, Vent & Drain Plug	O-ring, Vent & Drain Plug	O-ring, Vent & Drain Plug
77	Staybolt Nut	Staybolt Nut	Staybolt Nut	Staybolt Nut
78	Staybolt Washer	Staybolt Washer	Staybolt Washer	Staybolt Washer
80	Spring Washer	Spring Washer	Spring Washer	Spring Washer
81	Staybolt	Staybolt	Staybolt	Staybolt
82	O-ring, Sleeve	O-ring, Sleeve	O-ring, Sleeve	O-ring, Sleeve
86	n/a	Flange Retaining Ring	n/a	Flange Retaining Ring
95	Stack Height Gauge	Stack Height Gauge	Stack Height Gauge	Stack Height Gauge

# REPAIR PARTS

Cast Iron Models	Stainless Models
PVM10	PVMX10
PVM15	PVMX15
PVM20	PVMX20

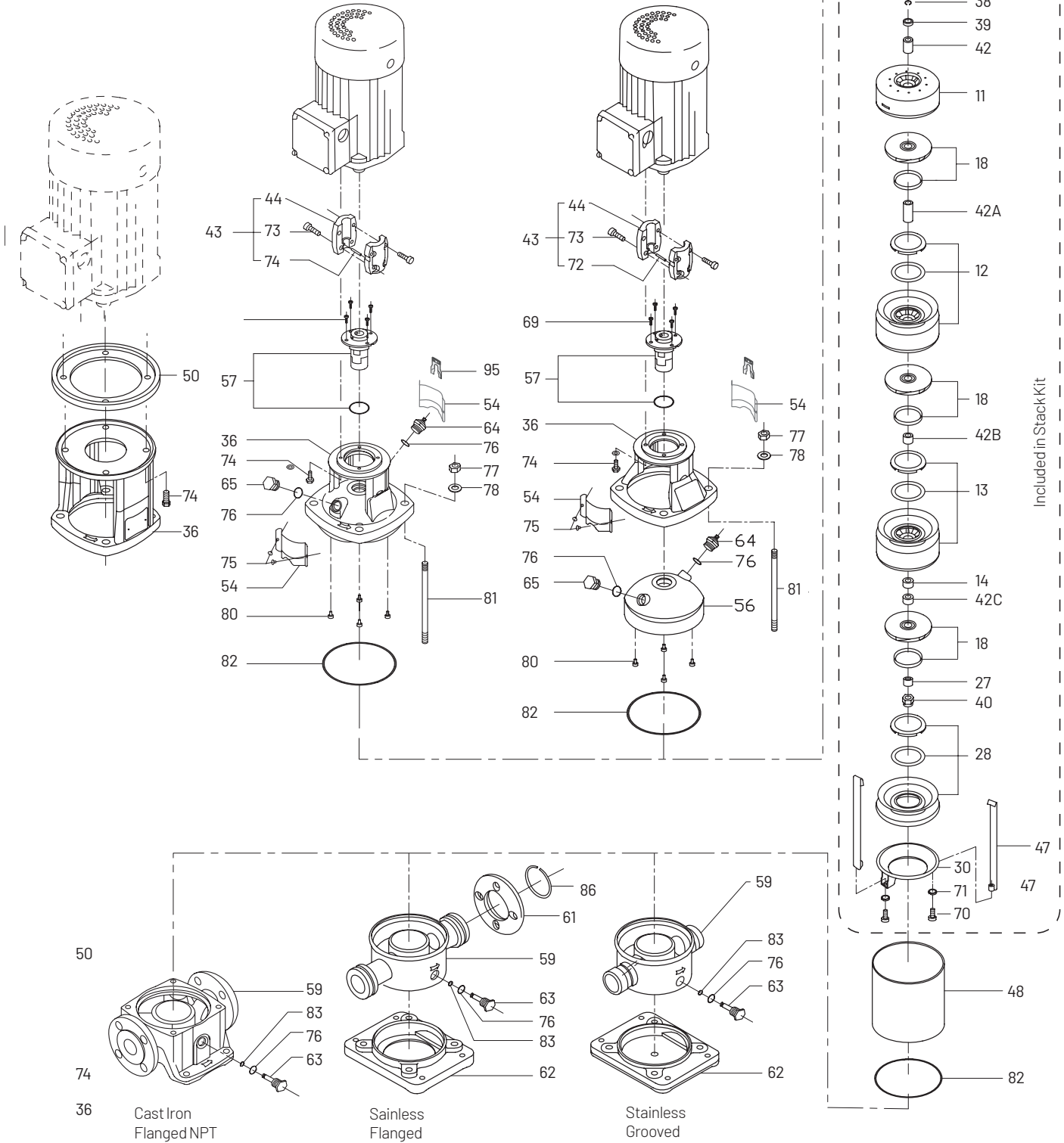

## REPAIR PARTS

Component	PVM10	PVMX10	PVM15, PVM20	PVMX15, PVMX20
11	Discharge	Discharge	Discharge	Discharge
12	Diffuser, Normal	Diffuser, Normal	Diffuser, Normal	Diffuser, Normal
13	Diffuser, with Bearing	Diffuser, with Bearing	Diffuser, with Bearing	Diffuser, with Bearing
14	Bearing	Bearing	Bearing	Bearing
18	Impeller	Impeller	Impeller	Impeller
24	Wear Ring	Wear Ring	Wear Ring	Wear Ring
25	Wear Ring Retainer	Wear Ring Retainer	Wear Ring Retainer	Wear Ring Retainer
27	Clamp	Clamp	Clamp	Clamp
28	Diffuser, Bottom	Diffuser, Bottom	Diffuser, Bottom	Diffuser, Bottom
30	Strap Retainer	Strap Retainer	Strap Retainer	Strap Retainer
36	Motor Stool	Motor Stool	Motor Stool	Motor Stool
37	Shaft	Shaft	Shaft	Shaft
38	Stack Washer	Stack Washer	Stack Washer	Stack Washer
39	Bushing	Bushing	Bushing	Bushing
40	Nut, Shaft	Nut, Shaft	Nut, Shaft	Nut, Shaft
42	Spacer	Spacer	Spacer	Spacer
42A	Spacer	Spacer	Spacer	Spacer
42B	Spacer	Spacer	Spacer	Spacer
42C	Spacer	Spacer	Spacer	Spacer
43	Coupling Assembly	Coupling Assembly	Coupling Assembly	Coupling Assembly
44	Coupling Half	Coupling Half	Coupling Half	Coupling Half
47	Strap	Strap	Strap	Strap
48	Sleeve	Sleeve	Sleeve	Sleeve
50	Motor Stool Adapter	Motor Stool Adapter	Motor Stool Adapter	Motor Stool Adapter
54	Coupling Guard	Coupling Guard	Coupling Guard	Coupling Guard
56	n/a	Pump Head	n/a	Pump Head
57	Mechanical Seal Assembly	Mechanical Seal Assembly	Mechanical Seal Assembly	Mechanical Seal Assembly
59	Base	Base	Base	Base
61	n/a	Connecting Flange	n/a	Connecting Flange
62	n/a	Base Plate	n/a	Base Plate
63	Drain Plug	Drain Plug	Drain Plug	Drain Plug
64	Vent Plug	Vent Plug	Vent Plug	Vent Plug
65	Pump Head Plug	Pump Head Plug	Pump Head Plug	Pump Head Plug
66	O-ring, Mechanical Seal	O-ring, Mechanical Seal	O-ring, Mechanical Seal	O-ring, Mechanical Seal
69	Screw, Mechanical Seal	Screw, Mechanical Seal	Screw, Mechanical Seal	Screw, Mechanical Seal
70	Bolt, Strap	Bolt, Strap	Bolt, Strap	Bolt, Strap
71	Washer, Strap	Washer, Strap	Washer, Strap	Washer, Strap
72	Shaft Pin	Shaft Pin	Shaft Pin	Shaft Pin
73	Bolt, Coupling	Bolt, Coupling	Bolt, Coupling	Bolt, Coupling
74	Bolt, Motor	Bolt, Motor	Bolt, Motor	Bolt, Motor
75	Screw, Coupling Guard	Screw, Coupling Guard	Screw, Coupling Guard	Screw, Coupling Guard
76	O-ring, Vent & Drain Plug	O-ring, Vent & Drain Plug	O-ring, Vent & Drain Plug	O-ring, Vent & Drain Plug
77	Staybolt Nut	Staybolt Nut	Staybolt Nut	Staybolt Nut
78	Staybolt Washer	Staybolt Washer	Staybolt Washer	Staybolt Washer
80	Stack Bumper	Stack Bumper	Stack Bumper	Stack Bumper
81	Staybolt	Staybolt	Staybolt	Staybolt
82	O-ring, Sleeve	O-ring, Sleeve	O-ring, Sleeve	O-ring, Sleeve
83	O-ring, Drain Plug	O-ring, Drain Plug	O-ring, Drain Plug	O-ring, Drain Plug
86	n/a	Flange Retaining Ring	n/a	Flange Retaining Ring
95	Stack Height Gauge	Stack Height Gauge	Stack Height Gauge	Stack Height Gauge

# REPAIR PARTS

Cast Iron Models	Stainless Models
PVM33	PVMX33
PVM45	PVMX45
PVM64	PVMX64
PVM90	PVMX90

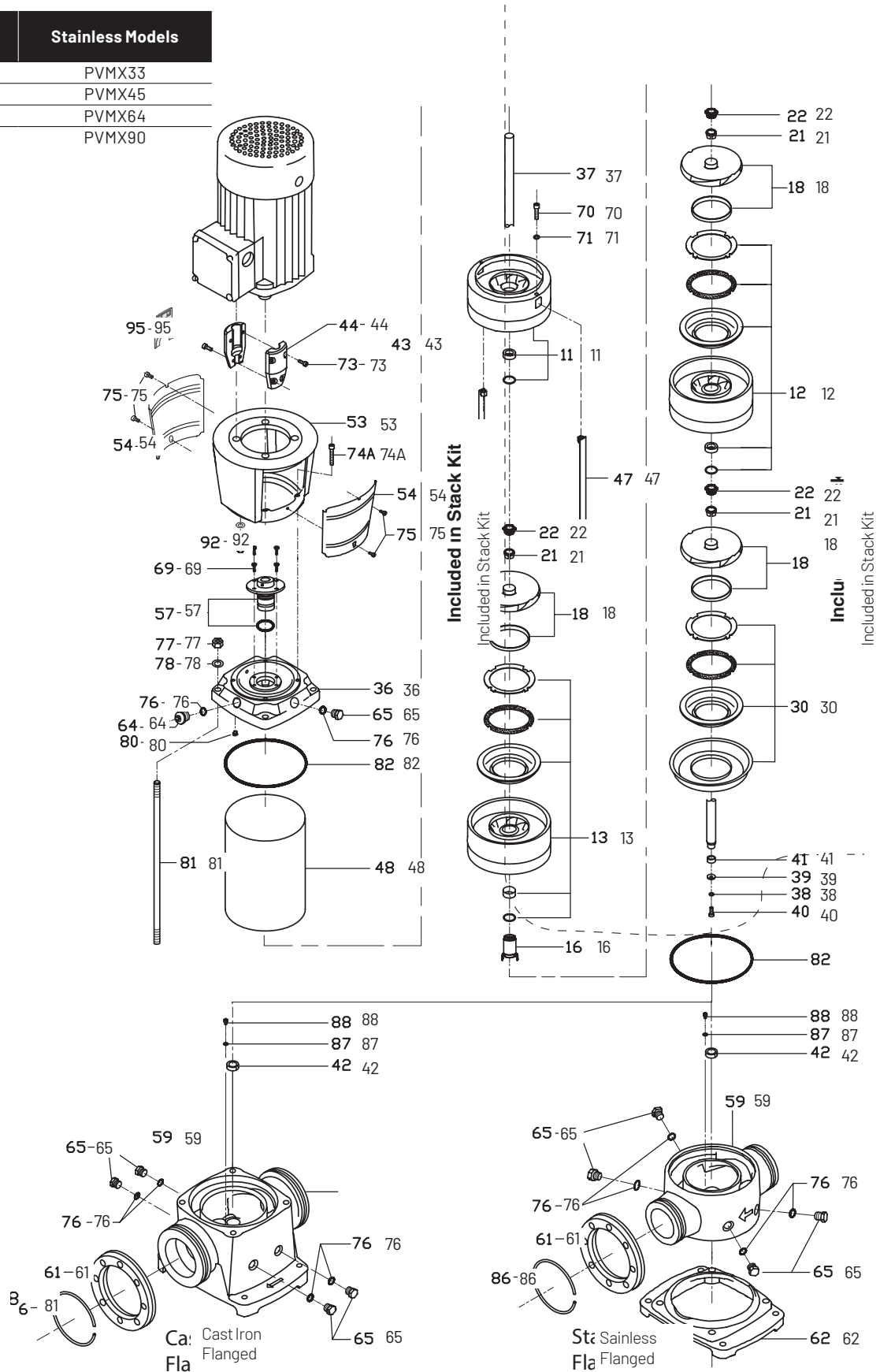

## REPAIR PARTS

Component	PVM33, PVM45, PVM64, PVM90	PVMX33, PVMX45, PVMX64, PVMX90
11	Diffuser, Top	Diffuser, Top
12	Diffuser, Normal	Diffuser, Normal
13	Diffuser, with Bearing	Diffuser, with Bearing
16	Bearing Sleeve	Bearing Sleeve
18	Impeller	Impeller
21	Collet	Collet
22	Collet Nut	Collet Nut
30	Strap Retainer	Strap Retainer
36	Pump Head	Pump Head
37	Shaft	Shaft
38	Spring Washer	Spring Washer
39	Clamp Washer	Clamp Washer
40	Bolt, Shaft	Bolt, Shaft
41	Bearing, Base, Inner	Bearing, Base, Inner
42	Bearing, Base, Outer	Bearing, Base, Outer
43	Coupling Assembly	Coupling Assembly
44	Coupling Half	Coupling Half
47	Strap	Strap
48	Sleeve	Sleeve
53	Motor Stool	Motor Stool
54	Coupling Guard	Coupling Guard
57	Mechanical Seal Assembly	Mechanical Seal Assembly
59	Base	Base
61	Connecting Flange	Connecting Flange
62	n/a	Base Plate
64	Vent Plug	Vent Plug
65	Plug, Base	Plug, Base
66	O-ring, Mechanical Seal	O-ring, Mechanical Seal
69	Screw, Mechanical Seal	Screw, Mechanical Seal
70	Bolt, Strap	Bolt, Strap
71	Washer, Strap	Washer, Strap
73	Bolt, Coupling	Bolt, Coupling
74A	Bolt, Pump Head	Bolt, Pump Head
75	Screw, Coupling Guard	Screw, Coupling Guard
76	O-ring, Vent & Drain Plug	O-ring, Vent & Drain Plug
77	Staybolt Nut	Staybolt Nut
78	Staybolt Washer	Staybolt Washer
80	Stack Bumper	Stack Bumper
81	Staybolt	Staybolt
82	O-ring, Sleeve	O-ring, Sleeve
86	Flange Retaining Ring	Flange Retaining Ring
87	Washer	Washer
88	Nut	Nut
92	Bolt, Motor	Bolt, Motor
95	Stack Height Gauge	Stack Height Gauge

# PUMP DIMENSIONS

## PVM(X)1 PUMP DIMENSIONS – STANDARD

					PVM Cast Iron								PVMX Stainless Steel								
					Motor Frame	Dimensions in inches						Weight in Lbs		Dimensions in inches						Weight in Lbs	
Model Number	Motor HP	Motor Service Factor	Phase	Voltage		A	B	C	D	E	F	Pump End Only	Pump & Motor	A	B	C	D	E	F	Pump End Only	Pump & Motor
PVM1-2	0.5	1.25	1	115V/208-230V	56C	11.0	9.3	6.0	2.1	22.4	6.0	38	59	11.1	9.3	6.0	2.1	22.5	6.0	32	53
PVM1-2	0.5	1.25	3	208-230V/460V	56C	11.0	10.2	6.6	2.1	23.2	6.6	38	73	11.1	10.2	6.6	2.1	23.3	6.6	32	67
PVM1-3	0.5	1.25	1	115V/208-230V	56C	11.0	9.3	6.0	2.1	22.4	6.0	39	60	11.1	9.3	6.0	2.1	22.5	6.0	33	54
PVM1-3	0.5	1.25	3	208-230V/460V	56C	11.0	10.2	6.6	2.1	23.2	6.6	39	74	11.1	10.2	6.6	2.1	23.3	6.6	33	68
PVM1-4	0.5	1.25	1	115V/208-230V	56C	11.7	9.3	6.0	2.1	23.1	6.0	40	61	11.8	9.3	6.0	2.1	23.2	6.0	35	56
PVM1-4	0.5	1.25	3	208-230V/460V	56C	11.7	10.2	6.6	2.1	23.9	6.6	40	75	11.8	10.2	6.6	2.1	24.0	6.6	35	70
PVM1-5	0.5	1.25	1	115V/208-230V	56C	12.4	9.3	6.0	2.1	23.8	6.0	42	63	12.5	9.3	6.0	2.1	23.9	6.0	36	57
PVM1-5	0.5	1.25	3	208-230V/460V	56C	12.4	10.2	6.6	2.1	24.6	6.6	42	77	12.5	10.2	6.6	2.1	24.7	6.6	36	71
PVM1-6	0.75	1.25	1	115V/208-230V	56C	13.1	9.9	6.0	2.1	25.1	6.0	43	72	13.2	9.9	6.0	2.1	25.2	6.0	37	66
PVM1-6	0.75	1.25	3	208-230V/460V	56C	13.1	10.2	6.6	2.1	25.3	6.6	43	73	13.2	10.2	6.6	2.1	25.4	6.6	37	67
PVM1-7	0.75	1.25	1	115V/208-230V	56C	14.1	9.9	6.0	2.1	26.1	6.0	44	73	14.2	9.9	6.0	2.1	26.2	6.0	39	68
PVM1-7	0.75	1.25	3	208-230V/460V	56C	14.1	10.2	6.6	2.1	26.3	6.6	44	74	14.2	10.2	6.6	2.1	26.4	6.6	39	69
PVM1-8	1	1.25	1	115V/208-230V	56C	14.8	10.2	6.6	2.1	27.0	6.6	46	81	14.9	10.2	6.6	2.1	27.1	6.6	40	75
PVM1-8	1	1.25	3	208-230V/460V	56C	14.8	10.4	7.2	2.1	27.3	7.2	46	99	14.9	10.4	7.2	2.1	27.4	7.2	40	93
PVM1-9	1	1.25	1	115V/208-230V	56C	15.5	10.2	6.6	2.1	27.7	6.6	47	82	15.6	10.2	6.6	2.1	27.8	6.6	41	76
PVM1-9	1	1.25	3	208-230V/460V	56C	15.5	10.4	7.2	2.1	28.0	7.2	47	100	15.6	10.4	7.2	2.1	28.1	7.2	41	94
PVM1-10	1.5	1.15	1	115V/208-230V	56C	16.2	11.2	7.2	2.1	29.4	7.2	48	94	16.3	11.2	7.2	2.1	29.5	7.2	42	88
PVM1-10	1.5	1.15	3	208-230V/460V	56C	16.2	11.2	7.2	2.1	29.4	7.2	48	90	16.3	11.2	7.2	2.1	29.5	7.2	42	84
PVM1-11	1.5	1.15	1	115V/208-230V	56C	16.9	11.2	7.2	2.1	30.1	7.2	49	95	17.0	11.2	7.2	2.1	30.2	7.2	44	90
PVM1-11	1.5	1.15	3	208-230V/460V	56C	16.9	11.2	7.2	2.1	30.1	7.2	49	91	17.0	11.2	7.2	2.1	30.2	7.2	44	86
PVM1-12	1.5	1.15	1	115V/208-230V	56C	17.6	11.2	7.2	2.1	30.8	7.2	51	97	17.7	11.2	7.2	2.1	30.9	7.2	45	91
PVM1-12	1.5	1.15	3	208-230V/460V	56C	17.6	11.2	7.2	2.1	30.8	7.2	51	93	17.7	11.2	7.2	2.1	30.9	7.2	45	87
PVM1-13	1.5	1.15	1	115V/208-230V	56C	18.3	11.2	7.2	2.1	31.5	7.2	52	98	18.4	11.2	7.2	2.1	31.6	7.2	46	92
PVM1-13	1.5	1.15	3	208-230V/460V	56C	18.3	11.2	7.2	2.1	31.5	7.2	52	94	18.4	11.2	7.2	2.1	31.6	7.2	46	88
PVM1-15	2	1.15	1	115V/208-230V	56C	20.4	12.1	7.2	2.1	34.5	7.2	55	108	20.5	12.1	7.2	2.1	34.6	7.2	49	102
PVM1-15	2	1.15	3	208-230V/460V	56C	20.4	12.1	7.2	2.1	34.5	7.2	55	104	20.5	12.1	7.2	2.1	34.6	7.2	49	98
PVM1-17	2	1.15	1	115V/208-230V	56C	21.8	12.1	7.2	2.1	35.9	7.2	57	110	21.9	12.1	7.2	2.1	36.0	7.2	52	105
PVM1-17	2	1.15	3	208-230V/460V	56C	21.8	12.1	7.2	2.1	35.9	7.2	57	106	21.9	12.1	7.2	2.1	36.0	7.2	52	101
PVM1-19	3	1.15	1	115V/208-230V	182TC	23.7	15.4	8.9	2.6	41.7	8.9	62	150	23.3	15.4	8.9	2.6	41.3	8.9	56	144
PVM1-19	3	1.15	3	208-230V/460V	182TC	23.7	13.9	8.9	2.6	40.3	8.9	62	130	23.3	13.9	8.9	2.6	39.9	8.9	56	124
PVM1-21	3	1.15	1	115V/208-230V	182TC	25.1	15.4	8.9	2.6	43.1	8.9	64	152	24.7	15.4	8.9	2.6	42.7	8.9	58	146
PVM1-21	3	1.15	3	208-230V/460V	182TC	25.1	13.9	8.9	2.6	41.7	8.9	64	132	24.7	13.9	8.9	2.6	41.3	8.9	58	126
PVM1-23	3	1.15	1	115V/208-230V	182TC	27.3	15.4	8.9	2.6	45.3	8.9	67	155	26.1	15.4	8.9	2.6	44.1	8.9	61	149
PVM1-23	3	1.15	3	208-230V/460V	182TC	27.3	13.9	8.9	2.6	43.9	8.9	67	135	26.1	13.9	8.7	2.6	42.7	8.7	61	129
PVM1-25	3	1.15	1	115V/208-230V	182TC	28.7	15.4	8.9	2.6	46.7	8.9	69	157	27.6	15.4	8.7	2.6	45.6	8.7	64	152
PVM1-25	3	1.15	3	208-230V/460V	182TC	28.7	13.9	8.9	2.6	45.3	8.9	69	137	27.6	13.9	8.7	2.6	44.2	8.7	64	132
PVM1-27	3	1.15	1	208-230V/460V	182TC	29.5	13.9	8.9	2.6	46.1	8.9	72	140	29.2	13.9	8.7	2.6	45.8	8.7	66	134
PVM1-27	3	1.15	3	115V/208-230V	182TC	29.5	15.4	8.9	2.6	47.5	8.9	72	160	29.2	15.4	8.7	2.6	47.2	8.7	66	154

# PUMP DIMENSIONS

## PVM(X)1 PUMP DIMENSIONS - STANDARD

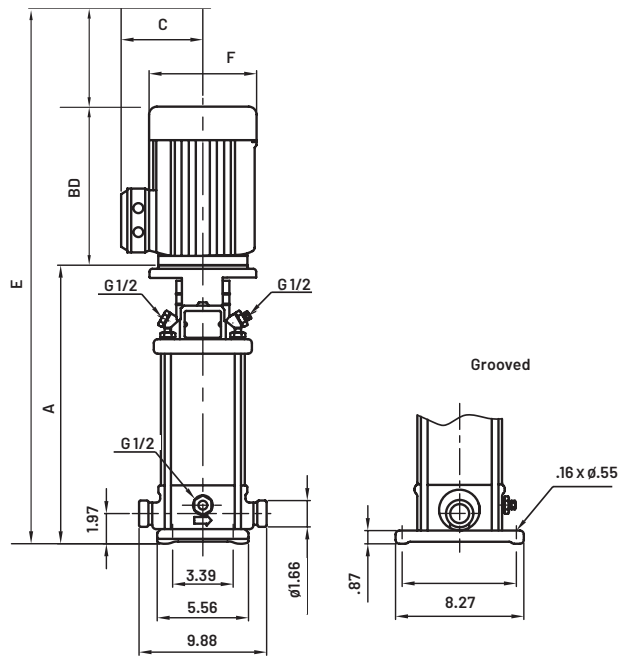
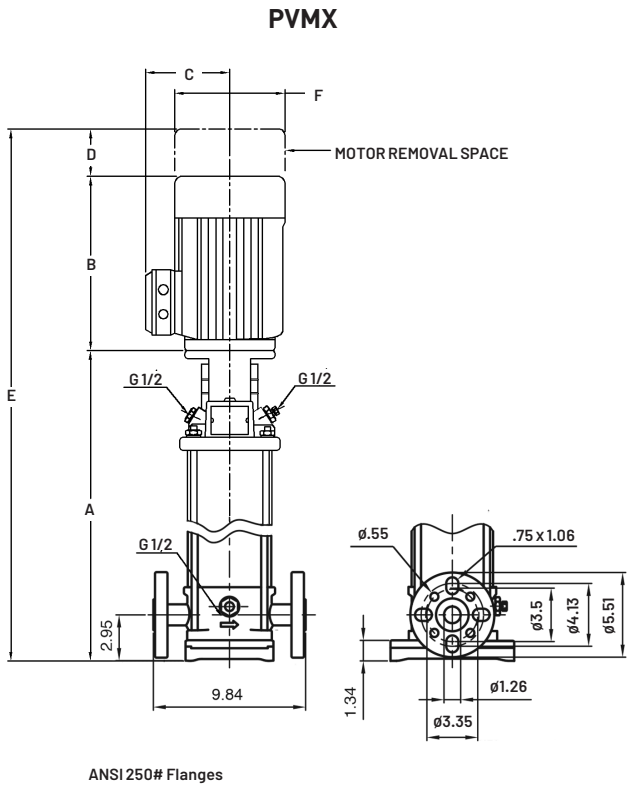
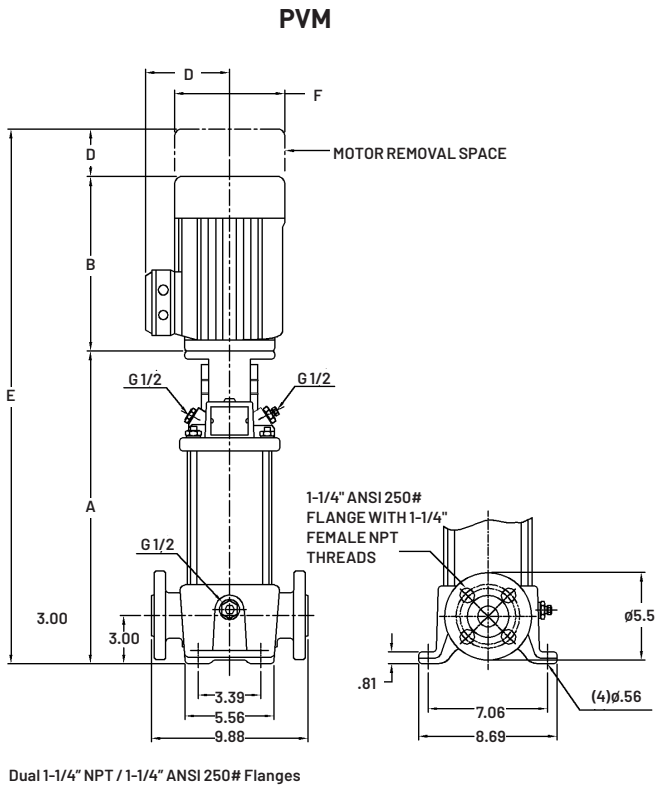

# PUMP DIMENSIONS

## PUMP DIMENSIONS – METRIC

					PVM Cast Iron								PVMX Stainless Steel								
					Motor Frame	Dimensions in inches						Weight in Kgs		Dimensions in mm						Weight in Kgs	
Model Number	Motor HP	Motor Service Factor	Phase	Voltage		A	B	C	D	E	F	Pump End Only	Pump & Motor	A	B	C	D	E	F	Pump End Only	Pump & Motor
PVM1-2	0.5	1.25	1	115V/208-230V	56C	279	236	153	52	568	153	17	27	282	236	153	52	570	153	15	24
PVM1-2	0.5	1.25	3	208-230V/460V	56C	279	258	168	52	590	168	17	33	282	258	168	52	593	168	15	30
PVM1-3	0.5	1.25	1	115V/208-230V	56C	279	236	153	52	568	153	18	27	282	236	153	52	570	153	15	25
PVM1-3	0.5	1.25	3	208-230V/460V	56C	279	258	168	52	590	168	18	34	282	258	168	52	593	168	15	31
PVM1-4	0.5	1.25	1	115V/208-230V	56C	297	236	153	52	586	153	18	28	300	236	153	52	588	153	16	25
PVM1-4	0.5	1.25	3	208-230V/460V	56C	297	258	168	52	608	168	18	34	300	258	168	52	610	168	16	32
PVM1-5	0.5	1.25	1	115V/208-230V	56C	315	236	153	52	603	153	19	28	318	236	153	52	606	153	16	26
PVM1-5	0.5	1.25	3	208-230V/460V	56C	315	258	168	52	626	168	19	35	318	258	168	52	628	168	16	32
PVM1-6	0.75	1.25	1	115V/208-230V	56C	333	252	153	52	637	153	19	33	335	252	153	52	639	153	17	30
PVM1-6	0.75	1.25	3	208-230V/460V	56C	333	258	168	52	643	168	19	33	335	258	168	52	646	168	17	30
PVM1-7	0.75	1.25	1	115V/208-230V	56C	358	252	153	52	662	153	20	33	361	252	153	52	665	153	17	31
PVM1-7	0.75	1.25	3	208-230V/460V	56C	358	258	168	52	669	168	20	34	361	258	168	52	671	168	17	31
PVM1-8	1	1.25	1	115V/208-230V	56C	376	258	168	52	686	168	21	37	378	258	168	52	689	168	18	34
PVM1-8	1	1.25	3	208-230V/460V	56C	376	264	183	52	693	183	21	45	378	264	183	52	695	183	18	42
PVM1-9	1	1.25	1	115V/208-230V	56C	394	258	168	52	704	168	21	37	396	258	168	52	707	168	19	35
PVM1-9	1	1.25	3	208-230V/460V	56C	394	264	183	52	711	183	21	45	396	264	183	52	713	183	19	43
PVM1-10	1.5	1.15	1	115V/208-230V	56C	411	283	182	52	747	182	22	43	414	283	182	52	750	182	19	40
PVM1-10	1.5	1.15	3	208-230V/460V	56C	411	284	183	52	748	183	22	41	414	284	183	52	750	183	19	38
PVM1-11	1.5	1.15	1	115V/208-230V	56C	429	283	182	52	765	182	22	43	432	283	182	52	768	182	20	41
PVM1-11	1.5	1.15	3	208-230V/460V	56C	429	284	183	52	765	183	22	41	432	284	183	52	768	183	20	39
PVM1-12	1.5	1.15	1	115V/208-230V	56C	447	283	182	52	783	182	23	44	450	283	182	52	785	182	20	41
PVM1-12	1.5	1.15	3	208-230V/460V	56C	447	284	183	52	783	183	23	42	450	284	183	52	786	183	20	39
PVM1-13	1.5	1.15	1	115V/208-230V	56C	465	283	182	52	801	182	24	44	467	283	182	52	803	182	21	42
PVM1-13	1.5	1.15	3	208-230V/460V	56C	465	284	183	52	801	183	24	43	467	284	183	52	803	183	21	40
PVM1-15	2	1.15	1	115V/208-230V	56C	518	306	182	52	877	182	25	49	521	306	182	52	879	182	22	46
PVM1-15	2	1.15	3	208-230V/460V	56C	518	306	183	52	877	183	25	47	521	306	183	52	879	183	22	44
PVM1-17	2	1.15	1	115V/208-230V	56C	554	306	182	52	912	182	26	50	556	306	182	52	915	182	23	47
PVM1-17	2	1.15	3	208-230V/460V	56C	554	306	183	52	912	183	26	48	556	306	183	52	915	183	23	46
PVM1-19	3	1.15	1	115V/208-230V	182TC	602	392	225	67	1060	225	28	68	592	392	225	67	1050	225	25	65
PVM1-19	3	1.15	3	208-230V/460V	182TC	602	354	225	67	1022	225	28	59	592	354	225	67	1012	225	25	56
PVM1-21	3	1.15	1	115V/208-230V	182TC	638	392	225	67	1096	225	29	69	627	392	225	67	1086	225	26	66
PVM1-21	3	1.15	3	208-230V/460V	182TC	638	354	225	67	1058	225	29	60	627	354	225	67	1048	225	26	57
PVM1-23	3	1.15	1	115V/208-230V	182TC	693	392	225	67	1152	225	30	70	663	392	225	67	1121	225	28	68
PVM1-23	3	1.15	3	208-230V/460V	182TC	693	354	225	67	1114	225	30	61	663	354	220	67	1083	220	28	59
PVM1-25	3	1.15	1	115V/208-230V	182TC	729	392	225	67	1187	225	31	71	701	392	220	67	1159	220	29	69
PVM1-25	3	1.15	3	208-230V/460V	182TC	729	354	225	67	1149	225	31	62	701	354	220	67	1122	220	29	60
PVM1-27	3	1.15	3	208-230V/460V	182TC	749	354	225	67	1170	225	33	63	742	354	220	67	1162	220	30	61
PVM1-27	3	1.15	1	115V/208-230V	182TC	749	392	225	67	1208	225	33	73	742	392	220	67	1200	220	30	70

# PUMP DIMENSIONS

## PVM(X) 1 PUMP DIMENSIONS - METRIC

### PVM

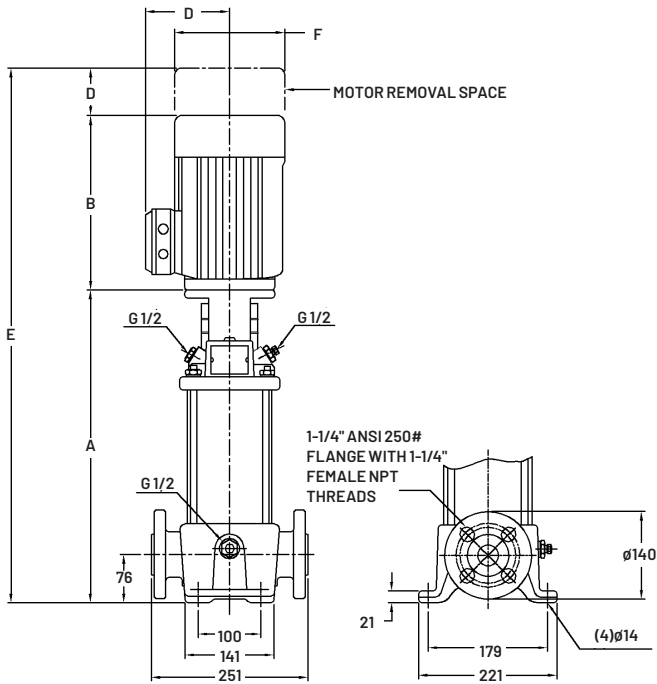

Dual 1-1/4" NPT / 1-1/4" ANSI 250# Flanges

### PVMX

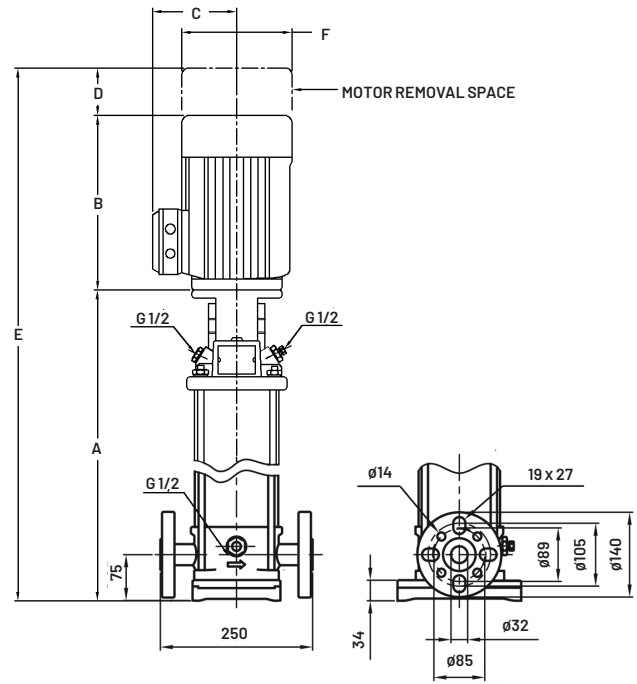

ANSI 250# Flanges

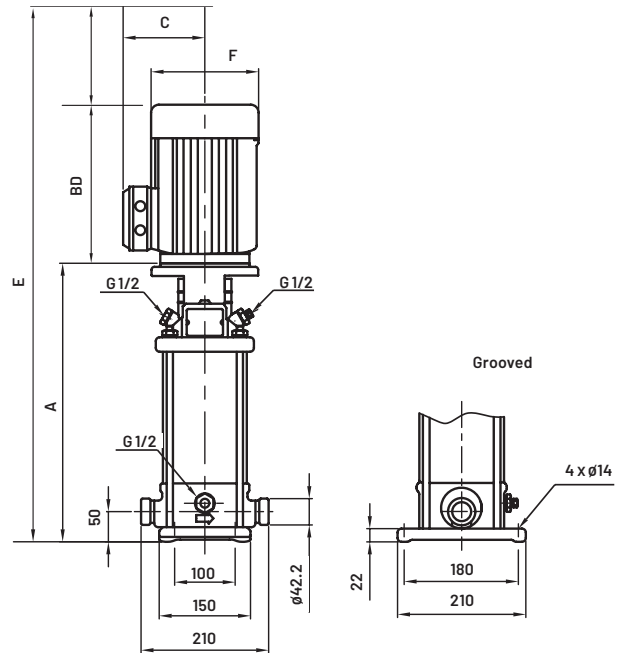

# PUMP DIMENSIONS

## PVM(X) 3 PUMP DIMENSIONS – STANDARD

					PVM Cast Iron								PVMX Stainless Steel								
					Motor Frame	Dimensions in inches						Weight in Lbs		Dimensions in inches						Weight in Lbs	
Model Number	Motor HP	Motor Service Factor	Phase	Voltage		A	B	C	D	E	F	Pump End Only	Pump & Motor	A	B	C	D	E	F	Pump End Only	Pump & Motor
PVM3-2	0.5	1.25	1	115V/208-230V	56C	11.0	9.3	6.0	2.1	22.4	6.0	38	59	11.1	9.3	6.0	2.1	22.5	6.0	32	53
PVM3-2	0.5	1.25	3	208-230V/460V	56C	11.0	10.2	6.6	2.1	23.2	6.6	38	73	11.1	10.2	6.6	2.1	23.3	6.6	32	67
PVM3-3	0.5	1.25	1	115V/208-230V	56C	11.0	9.3	6.0	2.1	22.4	6.0	39	60	11.1	9.3	6.0	2.1	22.5	6.0	33	54
PVM3-3	0.5	1.25	3	208-230V/460V	56C	11.0	10.2	6.6	2.1	23.2	6.6	39	74	11.1	10.2	6.6	2.1	23.3	6.6	33	68
PVM3-4	0.75	1.25	1	115V/208-230V	56C	11.7	9.9	6.0	2.1	23.7	6.0	40	69	11.8	9.9	6.0	2.1	23.8	6.0	35	64
PVM3-4	0.75	1.25	3	208-230V/460V	56C	11.7	10.2	6.6	2.1	23.9	6.6	40	70	11.8	10.2	6.6	2.1	24.0	6.6	35	65
PVM3-5	1	1.25	1	115V/208-230V	56C	12.6	10.2	6.6	2.1	24.8	6.6	42	77	12.8	10.2	6.6	2.1	25.0	6.6	36	71
PVM3-5	1	1.25	3	208-230V/460V	56C	12.6	10.4	7.2	2.1	25.1	7.2	42	95	12.8	10.4	7.2	2.1	25.3	7.2	36	89
PVM3-6	1	1.25	1	115V/208-230V	56C	13.3	10.2	6.6	2.1	25.5	6.6	43	78	13.5	10.2	6.6	2.1	25.7	6.6	37	72
PVM3-6	1	1.25	3	208-230V/460V	56C	13.3	10.4	7.2	2.1	25.8	7.2	43	96	13.5	10.4	7.2	2.1	26.0	7.2	37	90
PVM3-7	1.5	1.15	1	115V/208-230V	56C	14.0	11.2	7.2	2.1	27.2	7.2	44	90	14.2	11.2	7.2	2.1	27.4	7.2	39	85
PVM3-7	1.5	1.15	3	208-230V/460V	56C	14.0	11.2	7.2	2.1	27.2	7.2	44	86	14.2	11.2	7.2	2.1	27.4	7.2	39	81
PVM3-8	1.5	1.15	1	115V/208-230V	56C	14.8	11.2	7.2	2.1	28.0	7.2	46	92	14.9	11.2	7.2	2.1	28.1	7.2	40	86
PVM3-8	1.5	1.15	3	208-230V/460V	56C	14.8	11.2	7.2	2.1	28.0	7.2	46	88	14.9	11.2	7.2	2.1	28.1	7.2	40	82
PVM3-9	1.5	1.15	1	115V/208-230V	56C	16.1	11.2	7.2	2.1	29.3	7.2	47	93	16.2	11.2	7.2	2.1	29.4	7.2	41	87
PVM3-9	1.5	1.15	3	208-230V/460V	56C	16.1	11.2	7.2	2.1	29.3	7.2	47	89	16.2	11.2	7.2	2.1	29.4	7.2	41	83
PVM3-10	2	1.15	1	115V/208-230V	56C	16.8	12.1	7.2	2.1	30.9	7.2	48	101	16.9	12.1	7.2	2.1	31.0	7.2	42	95
PVM3-10	2	1.15	3	208-230V/460V	56C	16.8	12.1	7.2	2.1	30.9	7.2	48	97	16.9	12.1	7.2	2.1	31.0	7.2	42	91
PVM3-11	2	1.15	1	115V/208-230V	56C	17.5	12.1	7.2	2.1	31.6	7.2	49	102	17.6	12.1	7.2	2.1	31.7	7.2	44	97
PVM3-11	2	1.15	3	208-230V/460V	56C	17.5	12.1	7.2	2.1	31.6	7.2	49	98	17.6	12.1	7.2	2.1	31.7	7.2	44	93
PVM3-12	2	1.15	1	115V/208-230V	56C	18.2	12.1	7.2	2.1	32.3	7.2	51	104	18.3	12.1	7.2	2.1	32.4	7.2	45	98
PVM3-12	2	1.15	3	208-230V/460V	56C	18.2	12.1	7.2	2.1	32.3	7.2	51	100	18.3	12.1	7.2	2.1	32.4	7.2	45	94
PVM3-13	3	1.15	1	115V/208-230V	182TC	19.4	15.4	8.9	2.6	37.4	8.9	54	142	19.6	15.4	8.7	2.6	37.6	8.7	48	136
PVM3-13	3	1.15	3	208-230V/460V	182TC	19.4	13.9	8.9	2.6	36.0	8.9	54	122	19.6	13.9	8.7	2.6	36.2	8.7	48	116
PVM3-15	3	1.15	1	115V/208-230V	182TC	20.9	15.4	8.9	2.6	38.9	8.9	56	144	21.0	15.4	8.7	2.6	39.0	8.7	51	139
PVM3-15	3	1.15	3	208-230V/460V	182TC	20.9	13.9	8.9	2.6	37.5	8.9	56	124	21.0	13.9	8.7	2.6	37.6	8.7	51	119
PVM3-17	3	1.15	1	115V/208-230V	182TC	22.3	15.4	8.9	2.6	40.3	8.9	59	147	22.9	15.4	8.7	2.6	40.9	8.7	53	141
PVM3-17	3	1.15	3	208-230V/460V	182TC	22.3	13.9	8.9	2.6	38.9	8.9	59	127	22.9	13.9	8.7	2.6	39.5	8.7	53	121
PVM3-19	5	1.15	1	208-230V	213TC	24.3	15.5	9.6	3.1	42.9	9.6	62	179	24.5	15.5	9.6	3.1	43.1	9.6	56	173
PVM3-19	5	1.15	3	208-230V/460V	184TC	24.3	13.9	8.9	2.6	40.9	8.9	62	130	24.5	13.9	8.9	2.6	41.1	8.9	56	124
PVM3-21	5	1.15	1	208-230V	213TC	25.8	15.5	9.6	3.1	44.4	9.6	64	181	25.9	15.5	9.6	3.1	44.5	9.6	58	175
PVM3-21	5	1.15	3	208-230V/460V	184TC	25.8	13.9	8.9	2.6	42.4	8.9	64	132	25.9	13.9	8.9	2.6	42.5	8.9	58	126
PVM3-23	5	1.15	1	208-230V	213TC	27.2	15.5	9.6	3.1	45.8	9.6	67	184	27.3	15.5	9.6	3.1	45.9	9.6	61	178
PVM3-23	5	1.15	3	208-230V/460V	184TC	27.2	13.9	8.9	2.6	43.8	8.9	67	135	27.3	13.9	8.9	2.6	43.9	8.9	61	129
PVM3-25	5	1.15	1	208-230V	213TC	28.1	15.5	9.6	3.1	46.7	9.6	69	186	27.8	15.5	9.6	3.1	46.4	9.6	64	181
PVM3-25	5	1.15	3	208-230V/460V	184TC	28.1	13.9	8.9	2.6	44.7	8.9	69	137	27.8	13.9	8.9	2.6	44.4	8.9	64	132

# PUMP DIMENSIONS

## PVM(X) 3 PUMP DIMENSIONS – STANDARD

**PVM**

**PVMX**

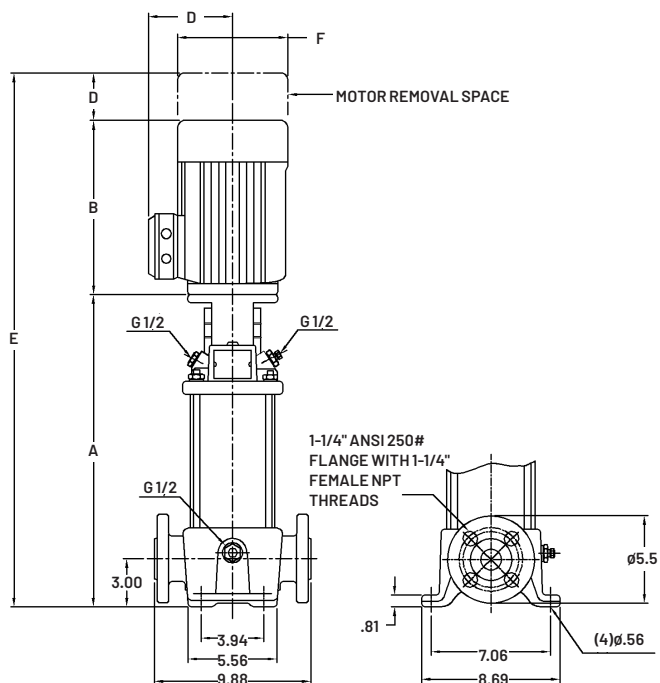

Dual 1-1/4" NPT / 1-1/4" ANSI 250# Flanges

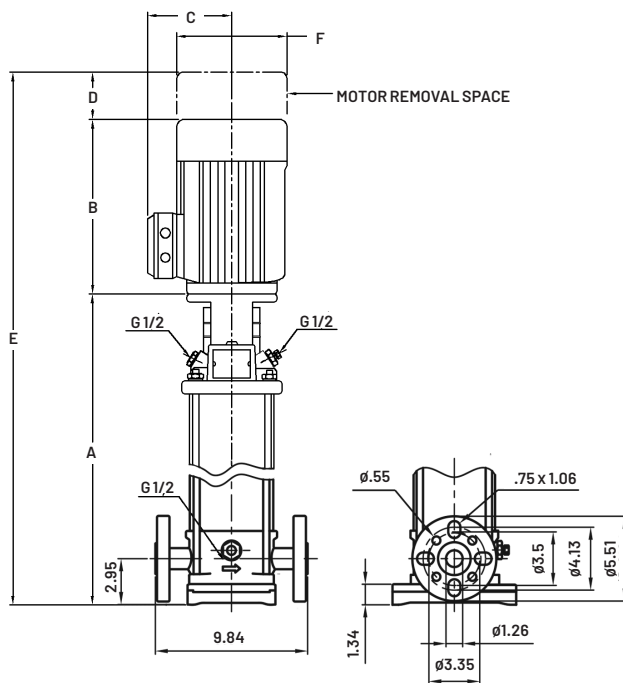

ANSI 250# Flanges

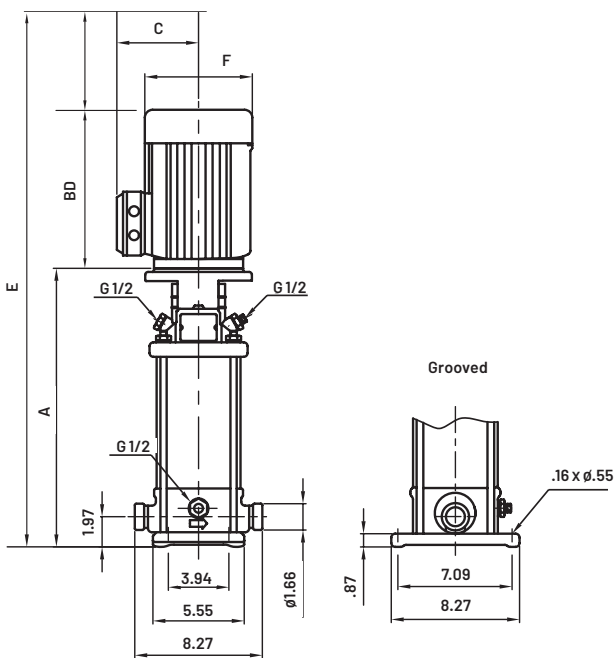

Grooved

# PUMP DIMENSIONS

## PVM(X) 3 PUMP DIMENSIONS – METRIC

					PVM Cast Iron								PVMX Stainless Steel								
					Motor Frame	Dimensions in inches						Weight in Kgs		Dimensions in mm						Weight in Kgs	
Model Number	Motor HP	Motor Service Factor	Phase	Voltage		A	B	C	D	E	F	Pump End Only	Pump & Motor	A	B	C	D	E	F	Pump End Only	Pump & Motor
PVM3-2	0.5	1.25	1	115V/208-230V	56C	279	236	153	52	568	153	17	27	282	236	153	52	570	153	15	24
PVM3-2	0.5	1.25	3	208-230V/460V	56C	279	258	168	52	590	168	17	33	282	258	168	52	593	168	15	30
PVM3-3	0.5	1.25	1	115V/208-230V	56C	279	236	153	52	568	153	18	27	282	236	153	52	570	153	15	25
PVM3-3	0.5	1.25	3	208-230V/460V	56C	279	258	168	52	590	168	18	34	282	258	168	52	593	168	15	31
PVM3-4	0.75	1.25	1	115V/208-230V	56C	297	252	153	52	601	153	18	31	300	252	153	52	604	153	16	29
PVM3-4	0.75	1.25	3	208-230V/460V	56C	297	258	168	52	608	168	18	32	300	258	168	52	610	168	16	29
PVM3-5	1	1.25	1	115V/208-230V	56C	320	258	168	52	631	168	19	35	325	258	168	52	636	168	16	32
PVM3-5	1	1.25	3	208-230V/460V	56C	320	264	183	52	637	183	19	43	325	264	183	52	642	183	16	40
PVM3-6	1	1.25	1	115V/208-230V	56C	338	258	168	52	648	168	19	35	343	258	168	52	653	168	17	33
PVM3-6	1	1.25	3	208-230V/460V	56C	338	264	183	52	655	183	19	43	343	264	183	52	660	183	17	41
PVM3-7	1.5	1.15	1	115V/208-230V	56C	356	283	182	52	691	182	20	41	361	283	182	52	697	182	17	38
PVM3-7	1.5	1.15	3	208-230V/460V	56C	356	284	183	52	692	183	20	39	361	284	183	52	697	183	17	37
PVM3-8	1.5	1.15	1	115V/208-230V	56C	376	283	182	52	712	182	21	41	378	283	182	52	714	182	18	39
PVM3-8	1.5	1.15	3	208-230V/460V	56C	376	284	183	52	712	183	21	40	378	284	183	52	715	183	18	37
PVM3-9	1.5	1.15	1	115V/208-230V	56C	409	283	182	52	745	182	21	42	411	283	182	52	747	182	19	40
PVM3-9	1.5	1.15	3	208-230V/460V	56C	409	284	183	52	745	183	21	40	411	284	183	52	748	183	19	38
PVM3-10	2	1.15	1	115V/208-230V	56C	427	306	182	52	785	182	22	46	429	306	182	52	788	182	19	43
PVM3-10	2	1.15	3	208-230V/460V	56C	427	306	183	52	785	183	22	44	429	306	183	52	788	183	19	41
PVM3-11	2	1.15	1	115V/208-230V	56C	445	306	182	52	803	182	22	46	447	306	182	52	806	182	20	44
PVM3-11	2	1.15	3	208-230V/460V	56C	445	306	183	52	803	183	22	45	447	306	183	52	806	183	20	42
PVM3-12	2	1.15	1	115V/208-230V	56C	462	306	182	52	821	182	23	47	465	306	182	52	823	182	20	44
PVM3-12	2	1.15	3	208-230V/460V	56C	462	306	183	52	821	183	23	45	465	306	183	52	823	183	20	43
PVM3-13	3	1.15	1	115V/208-230V	182TC	493	392	225	67	951	225	24	64	498	392	220	67	956	220	22	62
PVM3-13	3	1.15	3	208-230V/460V	182TC	493	354	225	67	913	225	24	55	498	354	220	67	918	220	22	53
PVM3-15	3	1.15	1	115V/208-230V	182TC	531	392	225	67	989	225	26	65	533	392	220	67	992	220	23	63
PVM3-15	3	1.15	3	208-230V/460V	182TC	531	354	225	67	951	225	26	56	533	354	220	67	954	220	23	54
PVM3-17	3	1.15	1	115V/208-230V	182TC	566	392	225	67	1025	225	27	67	582	392	220	67	1040	220	24	64
PVM3-17	3	1.15	3	208-230V/460V	182TC	566	354	225	67	987	225	27	58	582	354	220	67	1002	220	24	55
PVM3-19	5	1.15	1	208-230V	213TC	617	394	243	79	1090	243	28	81	622	394	243	79	1095	243	25	78
PVM3-19	5	1.15	3	208-230V/460V	184TC	617	354	225	67	1038	225	28	59	622	354	225	67	1043	225	25	56
PVM3-21	5	1.15	1	208-230V	213TC	655	394	243	79	1128	243	29	82	658	394	243	79	1131	243	26	80
PVM3-21	5	1.15	3	208-230V/460V	184TC	655	354	225	67	1076	225	29	60	658	354	225	67	1078	225	26	57
PVM3-23	5	1.15	1	208-230V	213TC	691	394	243	79	1164	243	30	83	693	394	243	79	1166	243	28	81
PVM3-23	5	1.15	3	208-230V/460V	184TC	691	354	225	67	1111	225	30	61	693	354	225	67	1114	225	28	59
PVM3-25	5	1.15	1	208-230V	213TC	714	394	243	79	1187	243	31	84	706	394	243	79	1179	243	29	82
PVM3-25	5	1.15	3	208-230V/460V	184TC	714	354	226	67	1134	226	31	62	706	354	225	67	1127	225	29	60

# PUMP DIMENSIONS

## PVM(X) 3 PUMP DIMENSIONS - METRIC

### PVM

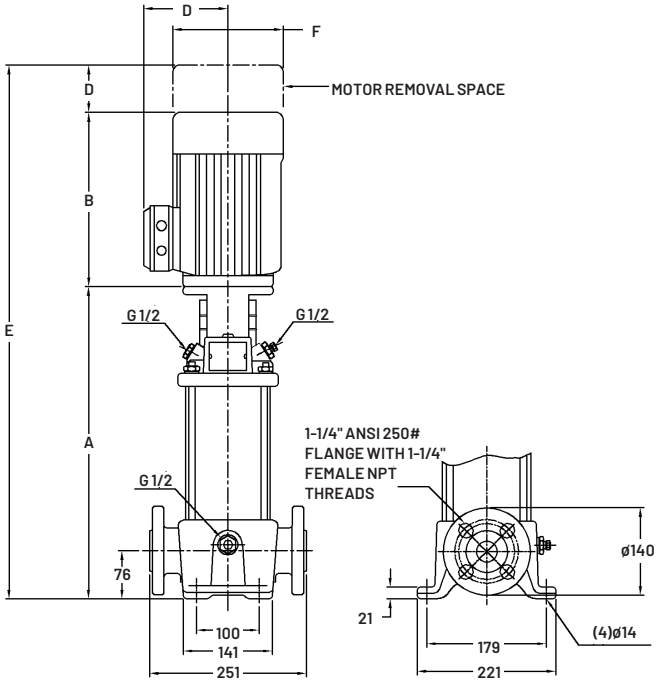

Dual 1-1/4" NPT / 1-1/4" ANSI 250# Flanges

### PVMX

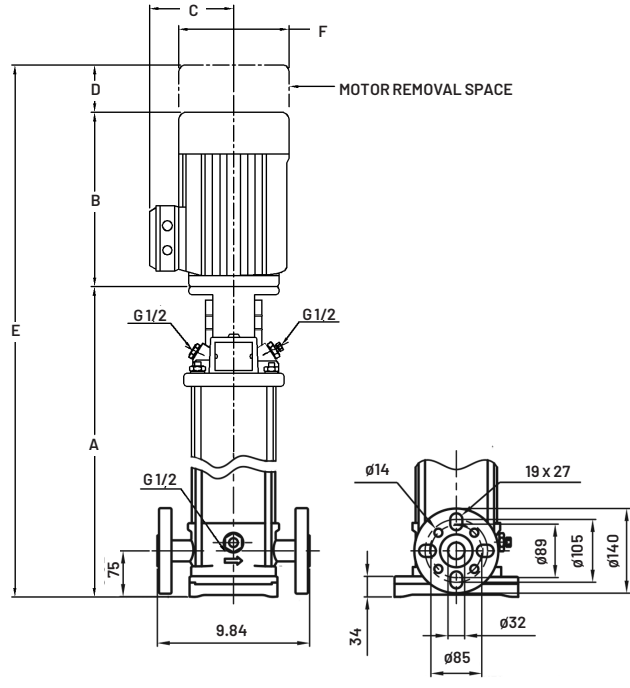

ANSI 250# Flanges

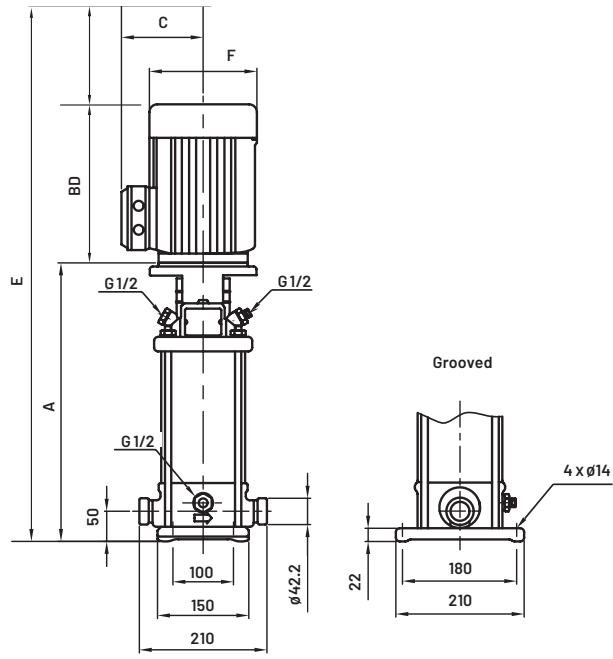

# PUMP DIMENSIONS

## PVM(X) 5 PUMP DIMENSIONS – STANDARD

					PVM Cast Iron								PVMX Stainless Steel								
					Motor Frame	Dimensions in inches						Weight in Lbs		Dimensions in inches						Weight in Lbs	
Model Number	Motor HP	Motor Service Factor	Phase	Voltage		A	B	C	D	E	F	Pump End Only	Pump & Motor	A	B	C	D	E	F	Pump End Only	Pump & Motor
PVM5-2	0.75	1.25	1	115V/208-230V	56C	11.0	9.9	6.0	2.1	23.0	6.0	38	67	11.1	9.9	6.0	2.1	23.1	6.0	32	61
PVM5-2	0.75	1.25	3	208-230V/460V	56C	11.0	10.2	6.6	2.1	23.2	6.6	38	68	11.1	10.2	6.6	2.1	23.3	6.6	32	62
PVM5-3	1	1.25	1	115V/208-230V	56C	12.3	10.2	6.6	2.1	24.5	6.6	39	74	12.4	10.2	6.6	2.1	24.6	6.6	33	68
PVM5-3	1	1.25	3	208-230V/460V	56C	12.3	10.4	7.2	2.1	24.8	7.2	39	92	12.4	10.4	7.2	2.1	24.9	7.2	33	86
PVM5-4	1.5	1.15	1	115V/208-230V	56C	13.3	11.2	7.2	2.1	26.5	7.2	40	86	13.5	11.2	7.2	2.1	26.7	7.2	35	81
PVM5-4	1.5	1.15	3	208-230V/460V	56C	13.3	11.2	7.2	2.1	26.5	7.2	40	82	13.5	11.2	7.2	2.1	26.7	7.2	35	77
PVM5-5	2	1.15	1	115V/208-230V	56C	15.0	12.1	7.2	2.1	29.1	7.2	42	95	15.2	12.1	7.2	2.1	29.3	7.2	36	89
PVM5-5	2	1.15	3	208-230V/460V	56C	15.0	12.1	7.2	2.1	29.1	7.2	42	91	15.2	12.1	7.2	2.1	29.3	7.2	36	85
PVM5-6	2	1.15	1	115V/208-230V	56C	16.1	12.1	7.2	2.1	30.2	7.2	43	96	16.2	12.1	7.2	2.1	30.3	7.2	37	90
PVM5-6	2	1.15	3	208-230V/460V	56C	16.1	12.1	7.2	2.1	30.2	7.2	43	92	16.2	12.1	7.2	2.1	30.3	7.2	37	86
PVM5-7	3	1.15	1	115V/208-230V	182TC	17.7	15.4	8.9	2.6	35.7	8.9	46	134	17.8	15.4	8.7	2.6	35.8	8.7	40	128
PVM5-7	3	1.15	3	208-230V/460V	182TC	17.7	13.9	8.9	2.6	34.3	8.9	46	114	17.8	13.9	8.7	2.6	34.4	8.7	40	108
PVM5-8	3	1.15	1	115V/208-230V	182TC	18.7	15.4	8.9	2.6	36.7	8.9	47	135	18.8	15.4	8.7	2.6	36.8	8.7	42	130
PVM5-8	3	1.15	3	208-230V/460V	182TC	18.7	13.9	8.9	2.6	35.3	8.9	47	115	18.8	13.9	8.7	2.6	35.4	8.7	42	110
PVM5-9	3	1.15	1	115V/208-230V	182TC	19.8	15.4	8.9	2.6	37.8	8.9	49	137	19.9	15.4	8.7	2.6	37.9	8.7	43	131
PVM5-9	3	1.15	3	208-230V/460V	182TC	19.8	13.9	8.9	2.6	36.4	8.9	49	117	19.9	13.9	8.7	2.6	36.5	8.7	43	111
PVM5-10	5	1.15	1	208-230V	213TC	21.0	15.5	9.6	3.1	39.6	9.6	50	167	21.2	15.5	9.6	3.1	39.8	9.6	44	161
PVM5-10	5	1.15	3	208-230V/460V	184TC	21.0	13.9	8.9	2.6	37.6	8.9	50	118	21.2	13.9	8.9	2.6	37.8	8.9	44	112
PVM5-11	5	1.15	1	208-230V	213TC	22.1	15.5	9.6	3.1	40.7	9.6	51	168	22.2	15.5	9.6	3.1	40.8	9.6	45	162
PVM5-11	5	1.15	3	208-230V/460V	184TC	22.1	13.9	8.9	2.6	38.7	8.9	51	119	22.2	13.9	8.9	2.6	38.8	8.9	45	113
PVM5-12	5	1.15	1	208-230V	213TC	23.1	15.5	9.6	3.1	41.7	9.6	52	169	23.3	15.5	9.6	3.1	41.9	9.6	47	164
PVM5-12	5	1.15	3	208-230V/460V	184TC	23.1	13.9	8.9	2.6	39.7	8.9	52	120	23.3	13.9	8.9	2.6	39.9	8.9	47	115
PVM5-13	5	1.15	1	208-230V	213TC	24.2	15.5	9.6	3.1	42.8	9.6	54	171	24.4	15.5	9.6	3.1	43.0	9.6	48	165
PVM5-13	5	1.15	3	208-230V/460V	184TC	24.2	13.9	8.9	2.6	40.8	8.9	54	122	24.4	13.9	8.9	2.6	41.0	8.9	48	116
PVM5-14	5	1.15	1	208-230V	213TC	25.3	15.5	9.6	3.1	43.9	9.6	55	172	25.4	15.5	9.6	3.1	44.0	9.6	49	166
PVM5-14	5	1.15	3	208-230V/460V	184TC	25.3	13.9	8.9	2.6	41.9	8.9	55	123	25.4	13.9	8.9	2.6	42.0	8.9	49	117
PVM5-15	5	1.15	1	208-230V	213TC	26.3	15.5	9.6	3.1	44.9	9.6	56	173	26.5	15.5	9.6	3.1	45.1	9.6	51	168
PVM5-15	5	1.15	3	208-230V/460V	184TC	26.3	13.9	8.9	2.6	42.9	8.9	56	124	26.5	13.9	8.9	2.6	43.1	8.9	51	119
PVM5-16	5	1.15	1	208-230V	213TC	27.4	15.5	9.6	3.1	46.0	9.6	58	175	27.5	15.5	9.6	3.1	46.1	9.6	52	169
PVM5-16	5	1.15	3	208-230V/460V	184TC	27.4	13.9	8.9	2.6	44.0	8.9	58	126	27.5	13.9	8.9	2.6	44.1	8.9	52	120
PVM5-18	7.5	1.15	1	208-230V	213TC	29.4	15.5	8.7	3.1	48.0	8.7	60	177	29.4	15.5	8.7	3.1	48.0	8.7	55	172
PVM5-18	7.5	1.15	3	208-230V/460V	213TC	29.4	15.5	9.6	3.1	48.1	9.6	60	158	29.4	15.5	9.6	3.1	48.1	9.6	55	153
PVM5-20	7.5	1.15	1	208-230V	213TC	31.5	15.5	8.7	3.1	50.1	8.7	63	180	31.6	15.5	8.7	3.1	50.2	8.7	57	174
PVM5-20	7.5	1.15	3	208-230V/460V	213TC	21.5	15.5	9.6	3.1	40.2	9.6	63	161	31.6	15.5	9.6	3.1	50.3	9.6	57	155
PVM5-22	7.5	1.15	1	208-230V	213TC	33.6	15.5	8.7	3.1	52.2	8.7	65	182	33.8	15.5	8.7	3.1	52.4	8.7	60	177
PVM5-22	7.5	1.15	3	208-230V/460V	213TC	33.6	15.5	9.6	3.1	52.3	9.6	65	163	33.8	15.5	9.6	3.1	52.5	9.6	60	158
PVM5-24	7.5	1.15	1	208-230V	213TC	35.7	15.5	8.7	3.1	54.3	8.7	68	185	35.9	15.5	8.7	3.1	54.5	8.7	62	179
PVM5-24	7.5	1.15	3	208-230V/460V	213TC	35.7	15.5	9.6	3.1	54.4	9.6	68	166	35.9	15.5	9.6	3.1	54.6	9.6	62	160

# PUMP DIMENSIONS

## PVM(X) 5 PUMP DIMENSIONS – STANDARD

**PVM**

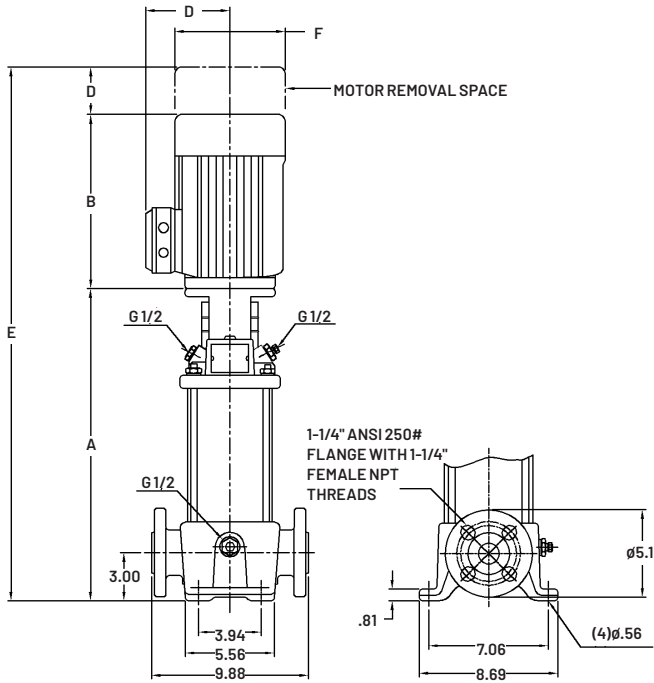

Dual 1-1/4" NPT / 1-1/4" ANSI 250# Flanges

**PVMX**

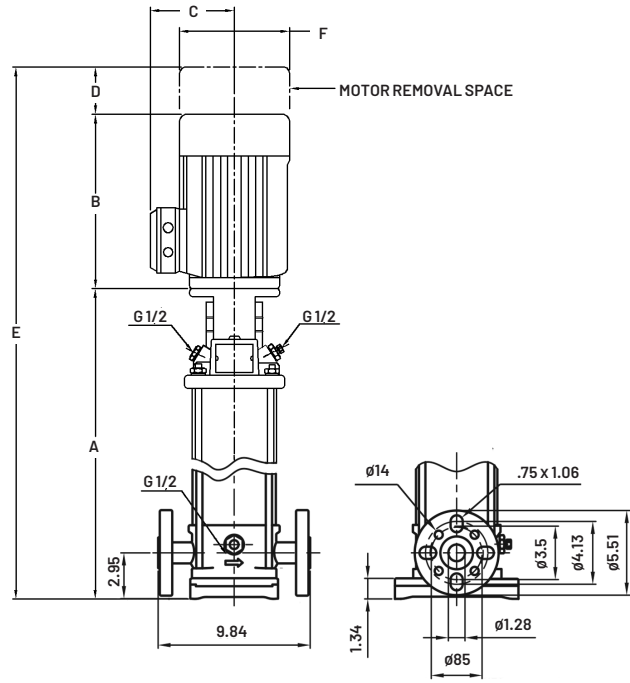

ANSI 250# Flanges

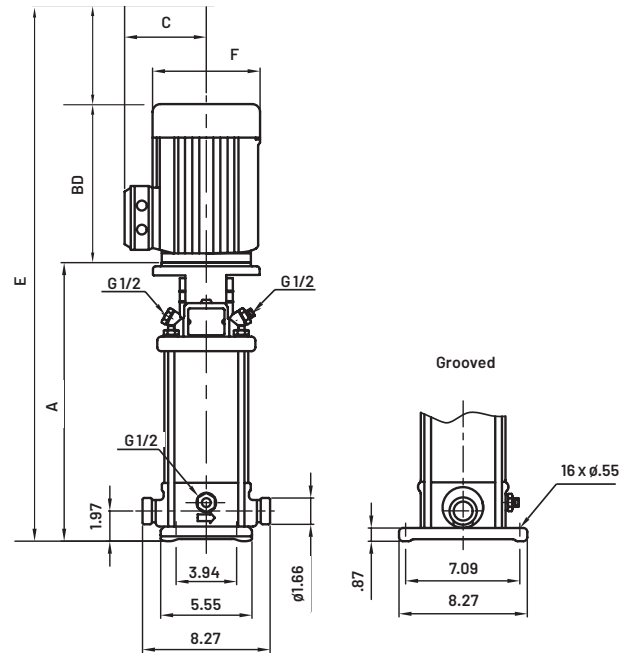

Grooved

# PUMP DIMENSIONS

## PVM(X) 5 PUMP DIMENSIONS – METRIC

					PVM Cast Iron								PVMX Stainless Steel								
					Motor Frame	Dimensions in inches						Weight in Kgs		Dimensions in mm						Weight in Kgs	
Model Number	Motor HP	Motor Service Factor	Phase	Voltage		A	B	C	D	E	F	Pump End Only	Pump & Motor	A	B	C	D	E	F	Pump End Only	Pump & Motor
PVM5-2	0.75	1.25	1	115V/208-230V	56C	279	252	153	52	584	153	17	30	282	252	153	52	586	153	15	28
PVM5-2	0.75	1.25	3	208-230V/460V	56C	279	258	168	52	590	168	17	31	282	258	168	52	593	168	15	28
PVM5-3	1	1.25	1	115V/208-230V	56C	312	258	168	52	623	168	18	34	315	258	168	52	625	168	15	31
PVM5-3	1	1.25	3	208-230V/460V	56C	312	264	183	52	629	183	18	42	315	264	183	52	632	183	15	39
PVM5-4	1.5	1.15	1	115V/208-230V	56C	338	283	182	52	674	182	18	39	343	283	182	52	679	182	16	37
PVM5-4	1.5	1.15	3	208-230V/460V	56C	338	284	183	52	674	183	18	37	343	284	183	52	679	183	16	35
PVM5-5	2	1.15	1	115V/208-230V	56C	381	306	182	52	739	182	19	43	386	306	182	52	745	182	16	40
PVM5-5	2	1.15	3	208-230V/460V	56C	381	306	183	52	739	183	19	41	386	306	183	52	745	183	16	39
PVM5-6	2	1.15	1	115V/208-230V	56C	409	306	182	52	767	182	19	43	411	306	182	52	770	182	17	41
PVM5-6	2	1.15	3	208-230V/460V	56C	409	306	183	52	767	183	19	42	411	306	183	52	770	183	17	39
PVM5-7	3	1.15	1	115V/208-230V	182TC	450	392	225	67	908	225	21	61	452	392	220	67	910	220	18	58
PVM5-7	3	1.15	3	208-230V/460V	182TC	450	354	225	67	870	225	21	52	452	354	220	67	873	220	18	49
PVM5-8	3	1.15	1	115V/208-230V	182TC	475	392	225	67	933	225	21	61	478	392	220	67	936	220	19	59
PVM5-8	3	1.15	3	208-230V/460V	182TC	475	354	225	67	895	225	21	52	478	354	220	67	898	220	19	50
PVM5-9	3	1.15	1	115V/208-230V	182TC	503	392	225	67	961	225	22	62	505	392	220	67	964	220	19	59
PVM5-9	3	1.15	3	208-230V/460V	182TC	503	354	225	67	923	225	22	53	505	354	220	67	926	220	19	50
PVM5-10	5	1.15	1	208-230V	213TC	533	394	243	79	1006	243	23	76	538	394	243	79	1012	243	20	73
PVM5-10	5	1.15	3	208-230V/460V	184TC	533	354	225	67	954	225	23	53	538	354	225	67	959	225	20	51
PVM5-11	5	1.15	1	208-230V	213TC	561	394	243	79	1034	243	23	76	564	394	243	79	1037	243	21	74
PVM5-11	5	1.15	3	208-230V/460V	184TC	561	354	225	67	982	225	23	54	564	354	225	67	984	225	21	51
PVM5-12	5	1.15	1	208-230V	213TC	587	394	243	79	1060	243	24	77	592	394	243	79	1065	243	21	74
PVM5-12	5	1.15	3	208-230V/460V	184TC	587	354	225	67	1007	225	24	55	592	354	225	67	1012	225	21	52
PVM5-13	5	1.15	1	208-230V	213TC	615	394	243	79	1088	243	24	77	620	394	243	79	1093	243	22	75
PVM5-13	5	1.15	3	208-230V/460V	184TC	615	354	225	67	1035	225	24	55	620	354	225	67	1040	225	22	53
PVM5-14	5	1.15	1	208-230V	213TC	643	394	243	79	1116	243	25	78	645	394	243	79	1118	243	22	75
PVM5-14	5	1.15	3	208-230V/460V	184TC	643	354	225	67	1063	225	25	56	645	354	225	67	1066	225	22	53
PVM5-15	5	1.15	1	208-230V	213TC	668	394	243	79	1141	243	26	79	673	394	243	79	1146	243	23	76
PVM5-15	5	1.15	3	208-230V/460V	184TC	668	354	225	67	1089	225	26	56	673	354	225	67	1094	225	23	54
PVM5-16	5	1.15	1	208-230V	213TC	696	394	243	79	1169	243	26	79	699	394	243	79	1172	243	24	77
PVM5-16	5	1.15	3	208-230V/460V	184TC	696	354	225	67	1116	225	26	57	699	354	225	67	1119	225	24	54
PVM5-18	7.5	1.15	1	208-230V	213TC	747	394	220	79	1220	220	27	80	747	394	220	79	1220	220	25	78
PVM5-18	7.5	1.15	3	208-230V/460V	213TC	747	395	243	79	1221	243	27	72	747	395	243	79	1221	243	25	69
PVM5-20	7.5	1.15	1	208-230V	213TC	800	394	220	79	1273	220	28	82	803	394	220	79	1276	220	26	79
PVM5-20	7.5	1.15	3	208-230V/460V	213TC	546	395	243	79	1020	243	28	73	803	395	243	79	1277	243	26	70
PVM5-22	7.5	1.15	1	208-230V	213TC	853	394	220	79	1327	220	30	83	859	394	220	79	1332	220	27	80
PVM5-22	7.5	1.15	3	208-230V/460V	213TC	853	395	243	79	1328	243	30	74	859	395	243	79	1333	243	27	72
PVM5-24	7.5	1.15	1	208-230V	213TC	907	394	220	79	1380	220	31	84	912	394	220	79	1385	220	28	81
PVM5-24	7.5	1.15	3	208-230V/460V	213TC	907	395	243	79	1381	243	31	75	912	395	243	79	1386	243	28	7

# PUMP DIMENSIONS

## PVM(X) 5 PUMP DIMENSIONS - METRIC

### PVM

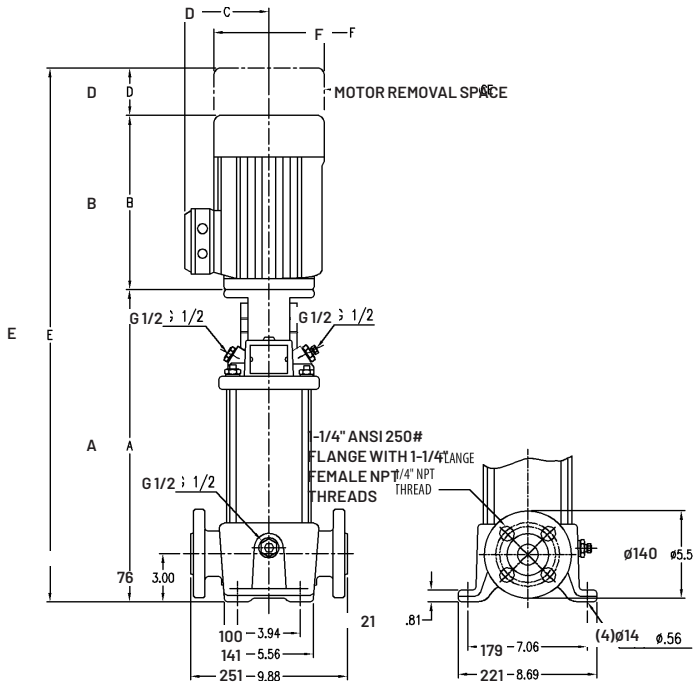

Dual 1-1/4" NPT / 1-1/4" ANSI 250# Flanges

### PVMX

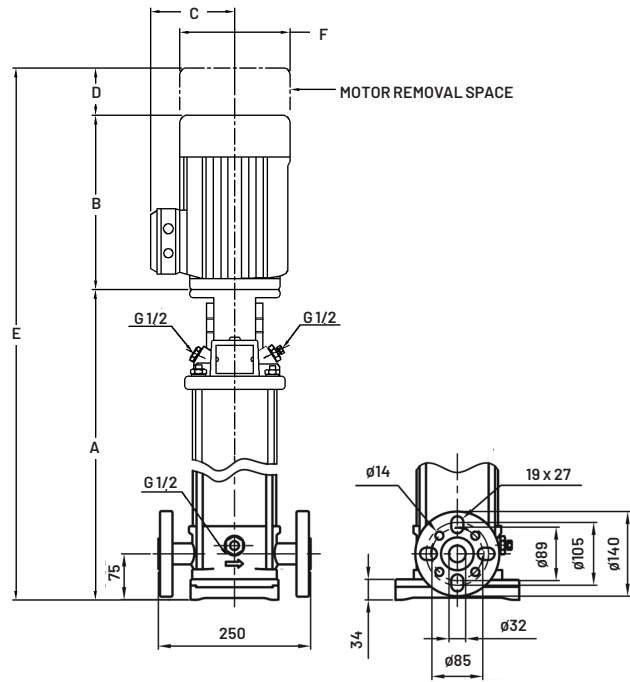

ANSI 250# Flanges

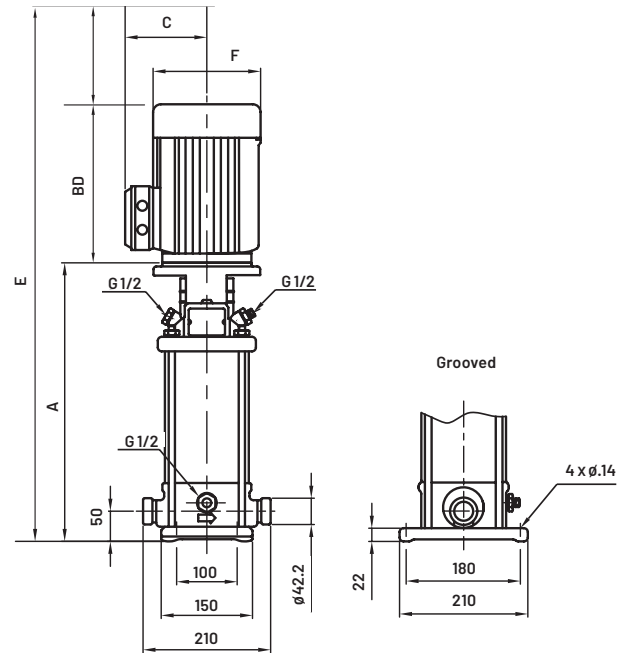

# PUMP DIMENSIONS

## PVM(X) 10 PUMP DIMENSIONS – STANDARD

					PVM Cast Iron									PVMX Stainless Steel							
					Motor Frame	Dimensions in inches						Weight in Lbs		Dimensions in inches						Weight in Lbs	
Model Number	Motor HP	Motor Service Factor	Phase	Voltage		A	B	C	D	E	F	Pump End Only	Pump & Motor	A	B	C	D	E	F	Pump End Only	Pump & Motor
PVM10-1	0.75	1.25	1	115V/208-230V	56C	13.7	9.9	6.0	2.1	25.7	6.0	61	90	14.1	9.9	6.0	2.1	26.1	6.0	50	79
PVM10-1	0.75	1.25	3	208-230V/460V	56C	13.7	10.2	6.6	2.1	25.9	6.6	61	91	14.1	10.2	6.6	2.1	26.3	6.6	50	80
PVM10-2	1.5	1.15	1	115V/208-230V	56C	14.3	11.2	7.2	2.1	27.5	7.2	67	113	14.7	11.2	7.2	2.1	27.9	7.2	56	102
PVM10-2	1.5	1.15	3	208-230V/460V	56C	14.3	11.2	7.2	2.1	27.5	7.2	67	109	14.7	11.2	7.2	2.1	27.9	7.2	56	98
PVM10-3	3	1.15	1	115V/208-230V	182TC	16.0	15.4	8.9	2.6	34.0	8.9	74	162	16.4	15.4	8.7	2.6	34.4	8.7	63	151
PVM10-3	3	1.15	3	208-230V/460V	182TC	16.0	13.9	8.9	2.6	32.6	8.9	74	142	16.4	13.9	8.7	2.6	33.0	8.7	63	131
PVM10-4	3	1.15	1	115V/208-230V	182TC	17.4	15.4	8.9	2.6	35.4	8.9	80	168	17.7	15.4	8.7	2.6	35.7	8.7	69	157
PVM10-4	3	1.15	3	208-230V/460V	182TC	17.4	13.9	8.9	2.6	34.0	8.9	80	148	17.7	13.9	8.7	2.6	34.3	8.7	69	137
PVM10-5	5	1.15	1	208-230V	213TC	18.5	15.5	9.6	3.1	37.1	9.6	86	203	18.9	15.5	9.6	3.1	37.5	9.6	75	192
PVM10-5	5	1.15	3	208-230V/460V	184TC	18.5	13.9	8.9	2.6	35.1	8.9	86	154	18.9	13.9	8.9	2.6	35.5	8.9	75	143
PVM10-6	5	1.15	1	208-230V	213TC	19.7	15.5	9.6	3.1	38.3	9.6	92	209	20.1	15.5	9.6	3.1	38.7	9.6	81	198
PVM10-6	5	1.15	3	208-230V/460V	184TC	19.7	13.9	8.9	2.6	36.3	8.9	92	160	20.1	13.9	8.9	2.6	36.7	8.9	81	149
PVM10-7	7.5	1.15	1	208-230V	213TC	20.9	15.5	8.7	3.1	39.5	8.7	98	215	21.2	15.5	8.7	3.1	39.8	8.7	87	204
PVM10-7	7.5	1.15	3	208-230V/460V	213TC	20.9	15.5	9.6	3.1	39.6	9.6	98	196	21.2	15.5	9.6	3.1	39.9	9.6	87	185
PVM10-8	7.5	1.15	1	208-230V	213TC	22.0	15.5	8.7	3.1	40.6	8.7	104	221	22.4	15.5	8.7	3.1	41.0	8.7	93	210
PVM10-8	7.5	1.15	3	208-230V/460V	213TC	22.0	15.5	9.6	3.1	40.7	9.6	104	202	22.4	15.5	9.6	3.1	41.1	9.6	93	191
PVM10-9	7.5	1.15	1	208-230V	213TC	23.2	15.5	8.7	3.1	41.8	8.7	110	227	23.5	15.5	8.7	3.1	42.1	8.7	99	216
PVM10-9	7.5	1.15	3	208-230V/460V	213TC	23.2	15.5	9.6	3.1	41.9	9.6	110	208	23.6	15.5	9.6	3.1	42.3	9.6	99	197
PVM10-10	7.5	1.15	1	208-230V	213TC	24.4	15.5	8.7	3.1	43.0	8.7	116	233	24.8	15.5	8.7	3.1	43.4	8.7	105	222
PVM10-10	7.5	1.15	3	208-230V/460V	213TC	24.4	15.5	9.6	3.1	43.1	9.6	116	214	24.8	15.5	9.6	3.1	43.5	9.6	105	203
PVM10-12	10	1.15	1	208-230V	215TC	26.8	16.6	9.6	3.1	46.5	9.6	129	264	27.2	16.6	9.6	3.1	46.9	9.6	117	252
PVM10-12	10	1.15	3	208-230V/460V	215TC	26.8	15.5	9.6	3.1	45.5	9.6	129	254	27.2	15.5	9.6	3.1	45.9	9.6	117	242
PVM10-14	15	1.15	3	208-230V/460V	254TC	31.0	20.0	12.9	3.8	54.8	12.9	141	416	31.3	20.0	12.9	3.8	55.1	12.9	130	405
PVM10-16	15	1.15	3	208-230V/460V	254TC	33.3	20.0	12.9	3.8	57.1	12.9	153	428	33.7	20.0	12.9	3.8	57.5	12.9	142	417

# PUMP DIMENSIONS

## PVM(X) 10 PUMP DIMENSIONS – STANDARD

### PVM

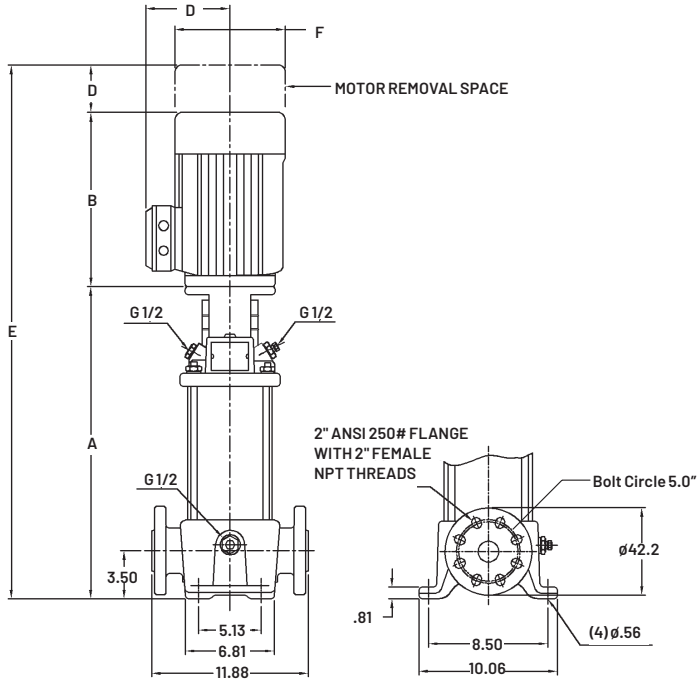

Dual 1-1/4" NPT / 1-1/4" ANSI 250# Flanges

### PVMX

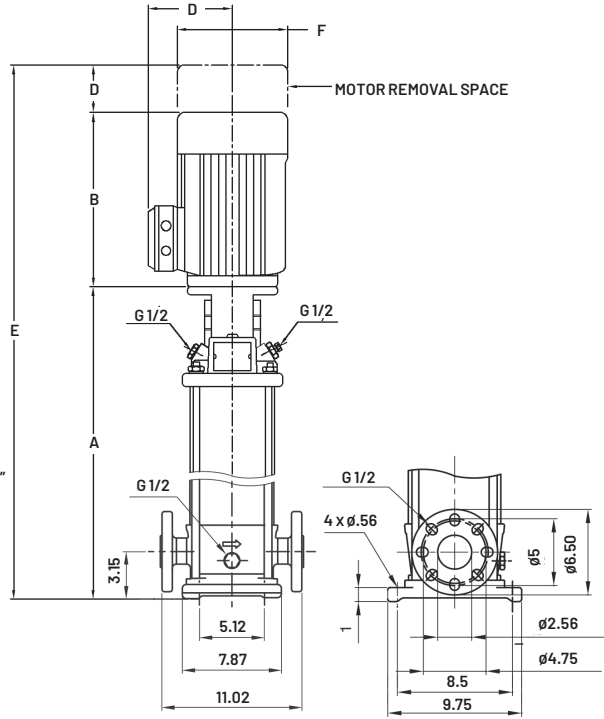

ANSI 250# Flanges

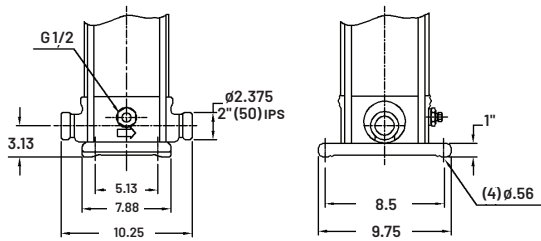

# PUMP DIMENSIONS

## PVM(X) 10 PUMP DIMENSIONS – METRIC

					PVM Cast Iron									PVMX Stainless Steel							
					Dimensions in inches						Weight in Kgs			Dimensions in mm						Weight in Kgs	
Model Number	Motor HP	Motor Service Factor	Phase	Voltage	Motor Frame	A	B	C	D	Ez	F	Pump End Only	Pump & Motor	A	B	C	D	E	F	Pump End Only	Pump & Motor
PVM10-1	0.75	1.25	1	115V/208-230V	56C	348	252	153	52	652	153	28	41	358	252	153	52	662	153	23	36
PVM10-1	0.75	1.25	3	208-230V/460V	56C	348	258	168	52	659	168	28	41	358	258	168	52	669	168	23	36
PVM10-2	1.5	1.15	1	115V/208-230V	56C	363	283	182	52	699	182	30	51	373	283	182	52	709	182	25	46
PVM10-2	1.5	1.15	3	208-230V/460V	56C	363	284	183	52	699	183	30	49	373	284	183	52	709	183	25	44
PVM10-3	3	1.15	1	115V/208-230V	182TC	406	392	225	67	865	225	33	73	417	392	220	67	875	220	28	68
PVM10-3	3	1.15	3	208-230V/460V	182TC	406	354	225	67	827	225	33	64	417	354	220	67	837	220	28	59
PVM10-4	3	1.15	1	115V/208-230V	182TC	442	392	225	67	900	225	36	76	450	392	220	67	908	220	31	71
PVM10-4	3	1.15	3	208-230V/460V	182TC	442	354	225	67	862	225	36	67	450	354	220	67	870	220	31	62
PVM10-5	5	1.15	1	208-230V	213TC	470	394	243	79	943	243	39	92	480	394	243	79	953	243	34	87
PVM10-5	5	1.15	3	208-230V/460V	184TC	470	354	225	67	890	225	39	70	480	354	225	67	901	225	34	65
PVM10-6	5	1.15	1	208-230V	213TC	500	394	243	79	973	243	42	95	511	394	243	79	984	243	37	90
PVM10-6	5	1.15	3	208-230V/460V	184TC	500	354	225	67	921	225	42	72	511	354	225	67	931	225	37	67
PVM10-7	7.5	1.15	1	208-230V	213TC	531	394	220	79	1004	220	44	97	538	394	220	79	1012	220	39	92
PVM10-7	7.5	1.15	3	208-230V/460V	213TC	531	395	243	79	1005	243	44	89	538	395	243	79	1013	243	39	84
PVM10-8	7.5	1.15	1	208-230V	213TC	559	394	220	79	1032	220	47	100	569	394	220	79	1042	220	42	95
PVM10-8	7.5	1.15	3	208-230V/460V	213TC	559	395	243	79	1033	243	47	91	569	395	243	79	1043	243	42	86
PVM10-9	7.5	1.15	1	208-230V	213TC	589	394	220	79	1062	220	50	103	597	394	220	79	1070	220	45	98
PVM10-9	7.5	1.15	3	208-230V/460V	213TC	589	395	243	79	1063	243	50	94	599	395	243	79	1074	243	45	89
PVM10-10	7.5	1.15	1	208-230V	213TC	620	394	220	79	1093	220	52	106	630	394	220	79	1103	220	47	100
PVM10-10	7.5	1.15	3	208-230V/460V	213TC	620	395	243	79	1094	243	52	97	630	395	243	79	1104	243	47	92
PVM10-12	10	1.15	1	208-230V	215TC	681	422	243	79	1182	243	58	120	691	422	243	79	1192	243	53	114
PVM10-12	10	1.15	3	208-230V/460V	215TC	681	394	243	79	1155	243	58	115	691	394	243	79	1165	243	53	110
PVM10-14	15	1.15	3	208-230V/460V	254TC	787	509	329	95	1391	329	64	189	795	509	329	95	1399	329	59	184
PVM10-16	15	1.15	3	208-230V/460V	254TC	846	509	329	95	1450	329	69	194	856	509	329	95	1460	329	64	189

# PUMP DIMENSIONS

## PVM(X) 10 PUMP DIMENSIONS - METRIC

### PVM

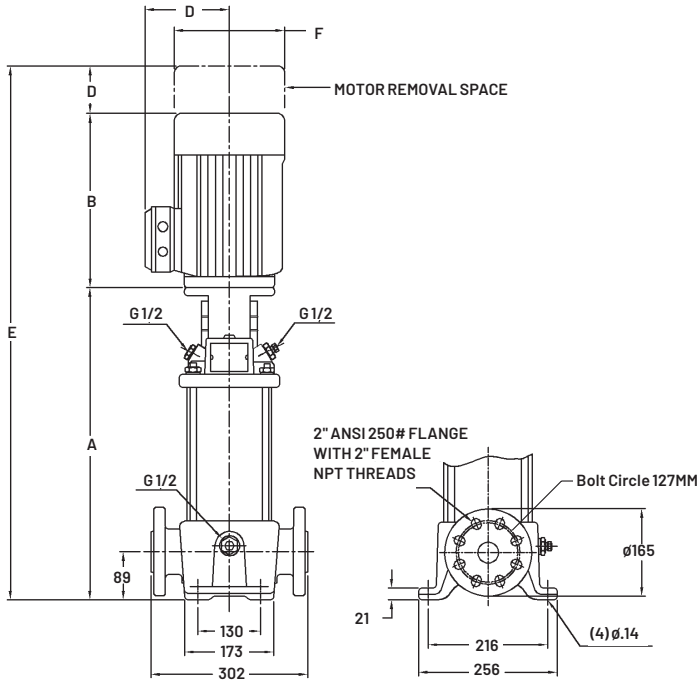

Dual 1-1/4" NPT / 1-1/4" ANSI 250# Flanges

### PVMX

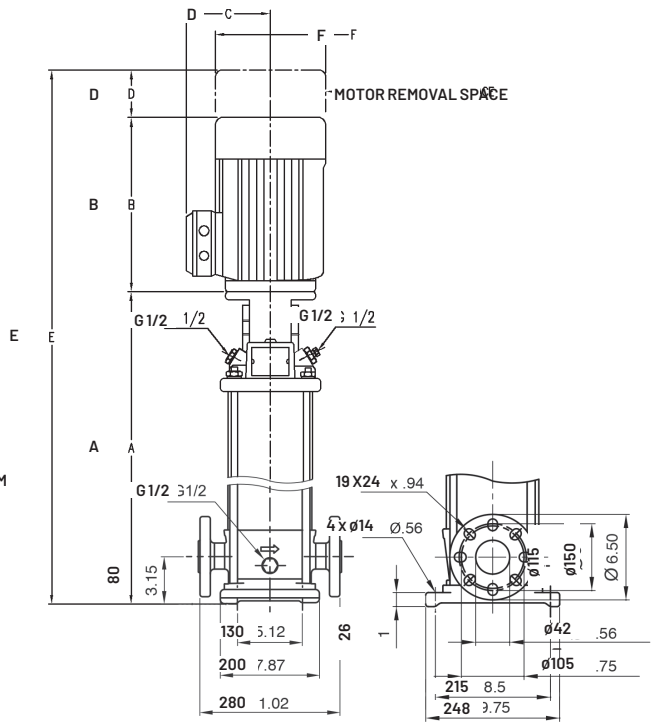

ANSI 250# Flanges

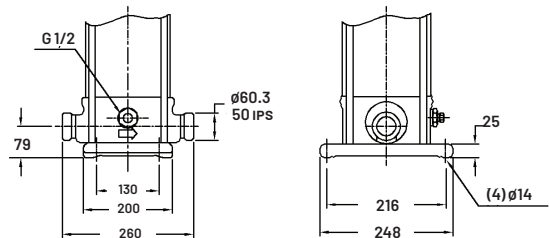

# PUMP DIMENSIONS

## PVM (X) 15 PUMP DIMENSIONS – STANDARD

MODEL NUMBER	MOTOR HP	MOTOR SAFETY FACTOR	PHASE	VOLTAGE	MOTOR FRAME	PVM CAST IRON							PVMX STAINLESS STEEL								
						DIMENSIONS IN INCHES						WEIGHT IN LBS		DIMENSIONS IN INCHES						WEIGHT IN LBS	
						A	B	C	D	E	F	PUMP END ONLY	PUMP & MOTOR	A	B	C	D	E	F	PUMP END ONLY	PUMP & MOTOR
PVM15-1	2	1.15	1	115V/208-230V	56C	16.3	12.1	7.2	2.1	30.4	7.2	65	118	16.3	12.1	7.2	2.1	30.4	7.2	54	107
PVM15-1	2	1.15	3	208-230V/460V	56C	16.3	12.1	7.2	2.1	30.4	7.2	65	114	16.3	12.1	7.2	2.1	30.4	7.2	54	103
PVM15-2	5	1.15	1	208-230V	213TC	17.0	15.5	9.6	3.1	35.6	9.6	76	193	17.0	15.5	9.6	3.1	35.6	9.6	65	182
PVM15-2	5	1.15	3	208-230V/460V	184TC	17.0	13.9	8.9	2.6	33.6	8.9	76	144	17.0	13.9	8.9	2.6	33.6	8.9	65	133
PVM15-3	7.5	1.15	1	208-230V	213TC	17.4	15.5	8.7	3.1	36.0	8.7	86	203	17.3	15.5	8.7	3.1	35.9	8.7	75	192
PVM15-3	7.5	1.15	3	208-230V/460V	213TC	17.4	15.5	9.6	3.1	36.1	9.6	86	184	17.3	15.5	9.6	3.1	36.0	9.6	75	173
PVM15-4	7.5	1.15	1	208-230V	213TC	20.5	15.5	8.7	3.1	39.1	8.7	96	213	19.1	15.5	8.7	3.1	37.7	8.7	85	202
PVM15-4	7.5	1.15	3	208-230V/460V	213TC	20.5	15.5	9.6	3.1	39.2	9.6	96	194	19.1	15.5	9.6	3.1	37.8	9.6	85	183
PVM15-5	10	1.15	1	208-230V	215TC	22.3	16.6	9.6	3.1	42.0	9.6	106	241	22.2	16.6	9.6	3.1	41.9	9.6	95	230
PVM15-5	10	1.15	3	208-230V/460V	215TC	22.3	15.5	9.6	3.1	41.0	9.6	106	231	22.2	15.5	9.6	3.1	40.9	9.6	95	220
PVM15-6	15	1.15	3	208-230V/460V	254TC	25.9	20.0	12.9	3.8	49.7	12.9	117	392	25.8	20.0	12.9	3.8	49.6	12.9	106	381
PVM15-7	15	1.15	3	208-230V/460V	254TC	27.7	20.0	12.9	3.8	51.5	12.9	127	402	27.6	20.0	12.9	3.8	51.4	12.9	116	391
PVM15-8	15	1.15	3	208-230V/460V	254TC	29.5	20.0	12.9	3.8	53.3	12.9	137	412	29.4	20.0	12.9	3.8	53.2	12.9	126	401
PVM15-9	20	1.15	3	230V/460V	254TC	31.2	16.9	10.3	3.8	51.8	10.3	147	372	31.1	16.9	10.3	3.8	51.7	10.3	136	361
PVM15-10	20	1.15	3	230V/460V	254TC	33.0	16.9	10.3	3.8	53.6	10.3	157	382	32.9	16.9	10.3	3.8	53.5	10.3	146	371
PVM15-12	25	1.15	3	230V/460V	284TSC	38.5	20.0	12.9	3.0	61.5	12.9	177	498	38.4	20.0	12.9	3.0	61.4	12.9	166	487

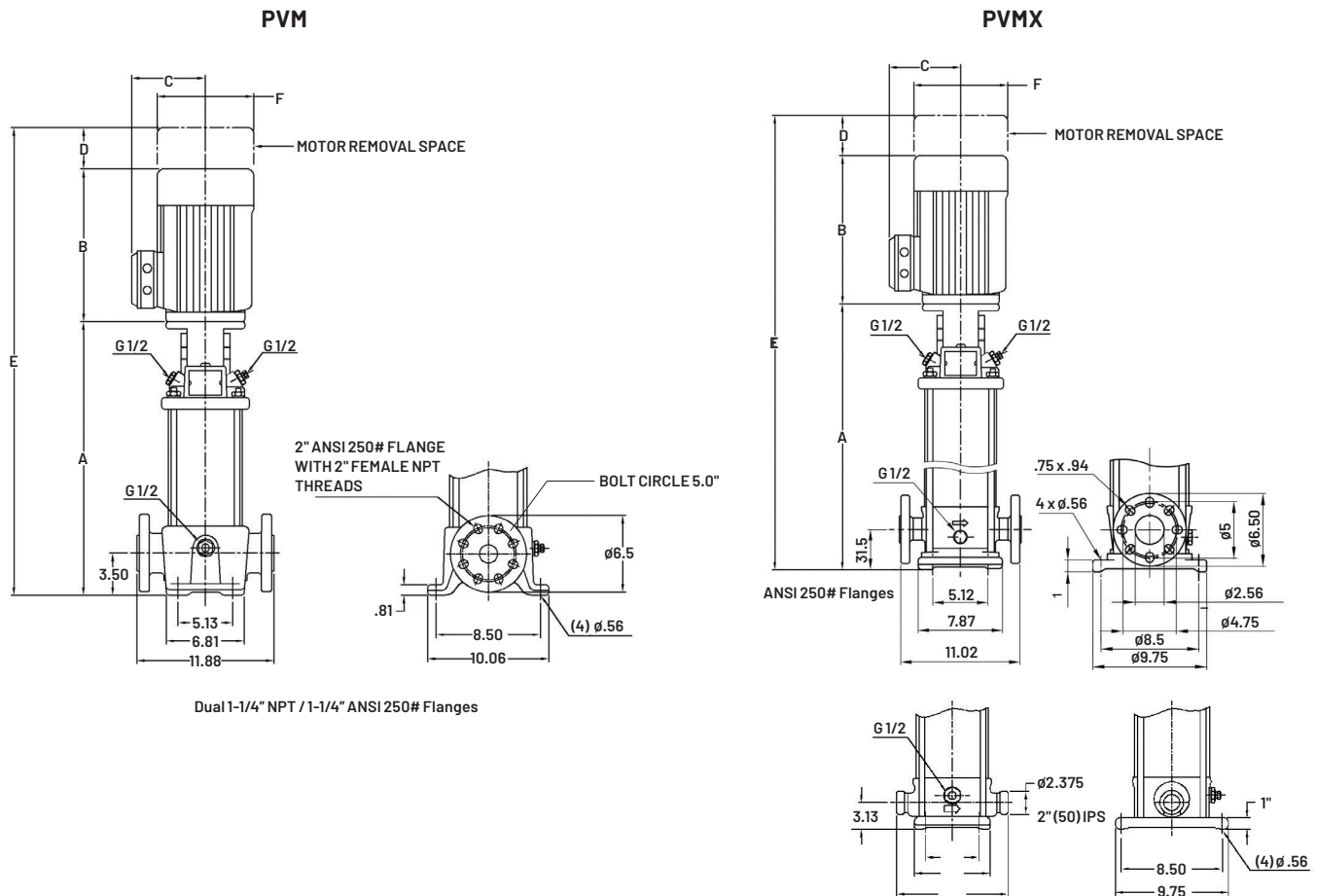

# PUMP DIMENSIONS

## PVM (X) 15 PUMP DIMENSIONS – METRIC

MODEL NUMBER	MOTOR HP	MOTOR SAFETY FACTOR	PHASE	VOLTAGE	MOTOR FRAME	PVM CAST IRON							PVMX STAINLESS STEEL								
						DIMENSIONS IN MM						WEIGHT IN KGS		DIMENSIONS IN MM						WEIGHT IN KGS	
						A	B	C	D	E	F	PUMP END ONLY	PUMP & MOTOR	A	B	C	D	E	F	PUMP END ONLY	PUMP & MOTOR
PVM15-1	2	1.15	1	115V/208-230V	56C	414	306	182	52	772	182	29	54	414	306	182	52	772	182	24	48
PVM15-1	2	1.15	3	208-230V/460V	56C	414	306	183	52	772	183	29	52	414	306	183	52	772	183	24	47
PVM15-2	5	1.15	1	208-230V	213TC	432	394	243	79	905	243	34	87	432	394	243	79	905	243	29	82
PVM15-2	5	1.15	3	208-230V/460V	184TC	432	354	225	67	852	225	34	65	432	354	225	67	852	225	29	60
PVM15-3	7.5	1.15	1	208-230V	213TC	442	394	220	79	915	220	39	92	439	394	220	79	912	220	34	87
PVM15-3	7.5	1.15	3	208-230V/460V	213TC	442	395	243	79	916	243	39	83	439	395	243	79	914	243	34	78
PVM15-4	7.5	1.15	1	208-230V	213TC	521	394	220	79	994	220	43	96	485	394	220	79	958	220	38	91
PVM15-4	7.5	1.15	3	208-230V/460V	213TC	521	395	243	79	995	243	43	88	485	395	243	79	959	243	38	83
PVM15-5	10	1.15	1	208-230V	215TC	566	422	243	79	1068	243	48	109	564	422	243	79	1065	243	43	104
PVM15-5	10	1.15	3	208-230V/460V	215TC	566	394	243	79	1040	243	48	105	564	394	243	79	1038	243	43	100
PVM15-6	15	1.15	3	208-230V/460V	254TC	658	509	329	95	1262	329	53	178	655	509	329	95	1259	329	48	173
PVM15-7	15	1.15	3	208-230V/460V	254TC	704	509	329	95	1308	329	58	182	701	509	329	95	1305	329	53	177
PVM15-8	15	1.15	3	208-230V/460V	254TC	749	509	329	95	1353	329	62	187	747	509	329	95	1351	329	57	182
PVM15-9	20	1.15	3	230V/460V	254TC	792	428	263	95	1316	263	67	169	790	428	263	95	1313	263	62	164
PVM15-10	20	1.15	3	230V/460V	254TC	838	428	263	95	1362	263	71	173	836	428	263	95	1359	263	66	168
PVM15-12	25	1.15	3	230V/460V	284TSC	978	507	329	76	1561	329	80	226	975	507	329	76	1559	329	75	221

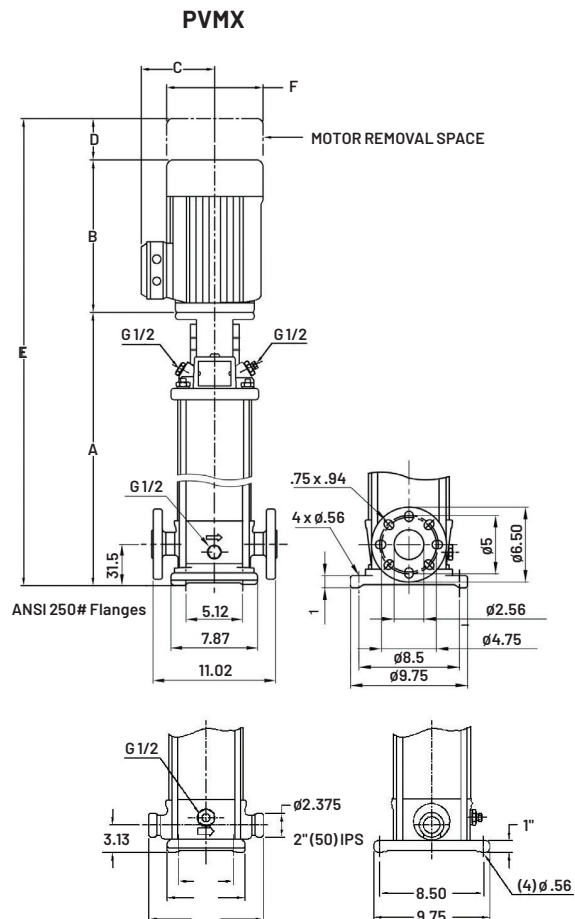
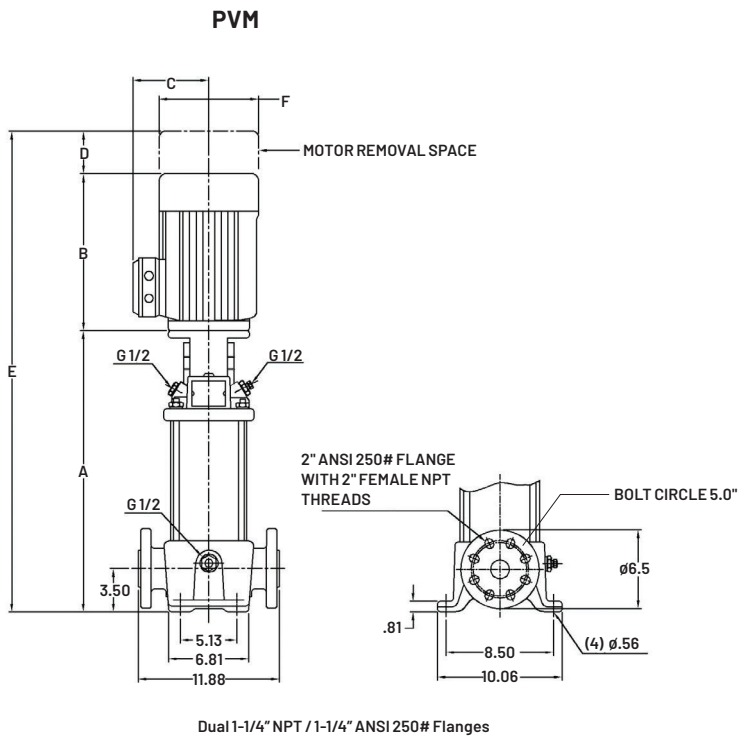

# PUMP DIMENSIONS

## PVM (X) 20 PUMP DIMENSIONS – STANDARD

MODEL NUMBER	MOTOR HP	MOTOR SERVICE FACTOR	PHASE	VOLTAGE	MOTOR FRAME	PVM CAST IRON							PVMX STAINLESS STEEL								
						DIMENSIONS IN INCHES						WEIGHT IN LBS		DIMENSIONS IN INCHES						WEIGHT IN LBS	
						A	B	C	D	E	F	PUMP END ONLY	PUMP & MOTOR	A	B	C	D	E	F	PUMP END ONLY	PUMP & MOTOR
PVM20-1	3	1.15	1	115V/208-230V	182TC	16.8	15.4	8.9	2.6	34.8	8.9	66	154	16.8	15.4	8.7	2.6	34.8	8.7	55	143
PVM20-1	3	1.15	3	208-230V/460V	182TC	16.8	13.9	8.9	2.6	33.4	8.9	66	134	16.8	13.9	8.7	2.6	33.4	8.7	55	123
PVM20-2	5	1.15	1	208-230V	213TC	17.0	15.5	9.6	3.1	35.6	9.6	76	193	17.0	15.5	9.6	3.1	35.6	9.6	65	182
PVM20-2	5	1.15	3	208-230V/460V	184TC	17.0	13.9	8.9	2.6	33.6	8.9	76	144	17.0	13.9	8.9	2.6	33.6	8.9	65	133
PVM20-3	7.5	1.15	1	208-230V	213TC	18.8	15.5	8.7	3.1	37.4	8.7	86	203	18.8	15.5	8.7	3.1	37.4	8.7	75	192
PVM20-3	7.5	1.15	3	208-230V/460V	213TC	18.8	15.5	9.6	3.1	37.5	9.6	86	184	18.8	15.5	9.6	3.1	37.5	9.6	75	173
PVM20-4	10	1.15	1	208-230V	215TC	20.5	16.6	9.6	3.1	40.2	9.6	96	231	20.5	16.6	9.6	3.1	40.2	9.6	85	220
PVM20-4	10	1.15	3	208-230V/460V	215TC	20.5	15.5	9.6	3.1	39.2	9.6	96	221	20.5	15.5	9.6	3.1	39.2	9.6	85	210
PVM20-5	15	1.15	3	208-230V/460V	254TC	24.1	20.0	12.9	3.8	47.9	12.9	107	382	24.1	20.0	12.9	3.8	47.9	12.9	96	371
PVM20-6	15	1.15	3	208-230V/460V	254TC	25.9	20.0	12.9	3.8	49.7	12.9	117	392	25.9	20.0	12.9	3.8	49.7	12.9	106	381
PVM20-7	20	1.15	3	230V/460V	254TC	27.7	16.9	10.3	3.8	48.3	10.3	127	352	27.7	16.9	10.3	3.8	48.3	10.3	116	341
PVM20-8	20	1.15	3	230V/460V	254TC	29.5	16.9	10.3	3.8	50.1	10.3	137	362	29.5	16.9	10.3	3.8	50.1	10.3	126	351
PVM20-10	25	1.15	3	230V/460V	284TSC	35.0	20.0	12.9	3.0	58.0	12.9	157	478	35.0	20.0	12.9	3.0	58.0	12.9	146	467

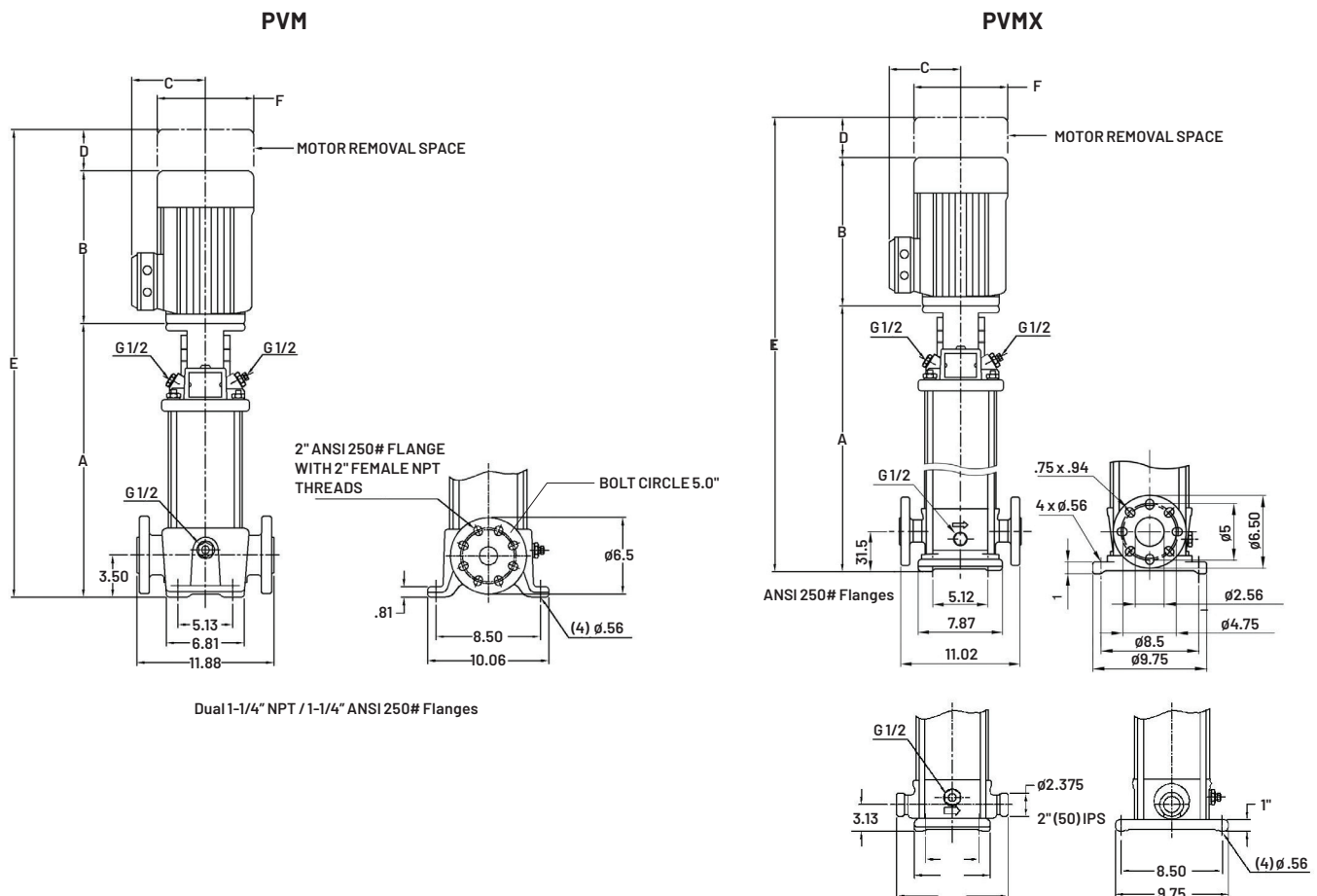

# PUMP DIMENSIONS

## PVM (X) 20 PUMP DIMENSIONS – METRIC

MODEL NUMBER	MOTOR HP	MOTOR SAFETY FACTOR	PHASE	VOLTAGE	MOTOR FRAME	PVM CAST IRON							PVMX STAINLESS STEEL								
						DIMENSIONS IN MM						WEIGHT IN KGS		DIMENSIONS IN MM						WEIGHT IN KGS	
						A	B	C	D	E	F	PUMP END ONLY	PUMP & MOTOR	A	B	C	D	E	F	PUMP END ONLY	PUMP & MOTOR
PVM20-1	3	1.15	1	115V/208-230V	182TC	427	392	225	67	885	225	30	70	427	392	220	67	885	220	25	65
PVM20-1	3	1.15	3	208-230V/460V	182TC	427	354	225	67	847	225	30	61	427	354	220	67	847	220	25	56
PVM20-2	5	1.15	1	208-230V	213TC	432	394	243	79	905	243	34	87	432	394	243	79	905	243	29	82
PVM20-2	5	1.15	3	208-230V/460V	184TC	432	354	225	67	852	225	34	65	432	354	225	67	852	225	29	60
PVM20-3	7.5	1.15	1	208-230V	213TC	478	394	220	79	951	220	39	92	478	394	220	79	951	220	34	87
PVM20-3	7.5	1.15	3	208-230V/460V	213TC	478	395	243	79	952	243	39	83	478	395	243	79	952	243	34	78
PVM20-4	10	1.15	1	208-230V	215TC	521	422	243	79	1022	243	43	105	521	422	243	79	1022	243	38	100
PVM20-4	10	1.15	3	208-230V/460V	215TC	521	394	243	79	995	243	43	100	521	394	243	79	995	243	38	95
PVM20-5	15	1.15	3	208-230V/460V	254TC	612	509	329	95	1216	329	49	173	612	509	329	95	1216	329	43	168
PVM20-6	15	1.15	3	208-230V/460V	254TC	658	509	329	95	1262	329	53	178	658	509	329	95	1262	329	48	173
PVM20-7	20	1.15	3	230V/460V	254TC	704	428	263	95	1227	263	58	160	704	428	263	95	1227	263	53	155
PVM20-8	20	1.15	3	230V/460V	254TC	749	428	263	95	1273	263	62	164	749	428	263	95	1273	263	57	159
PVM20-10	25	1.15	3	230V/460V	284TSC	889	507	329	76	1472	329	71	217	889	507	329	76	1472	329	66	212

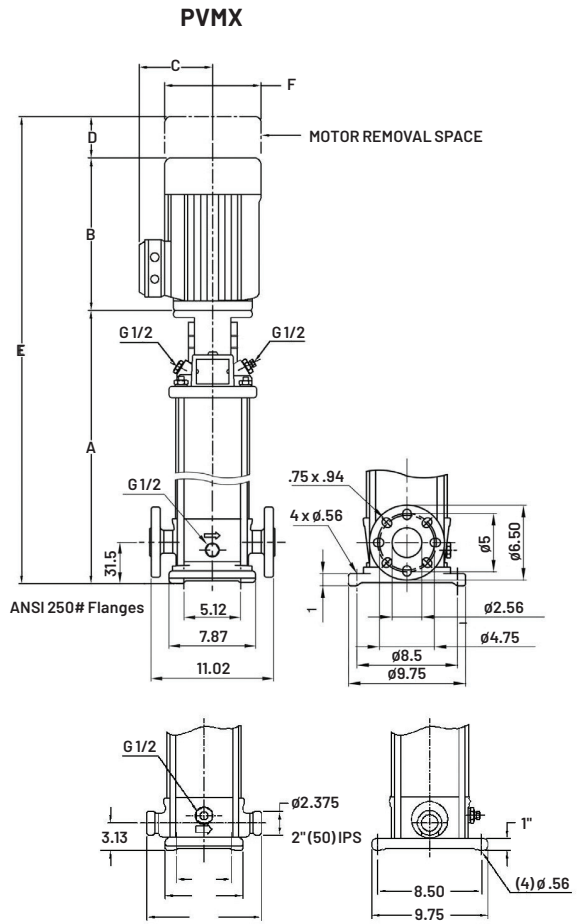
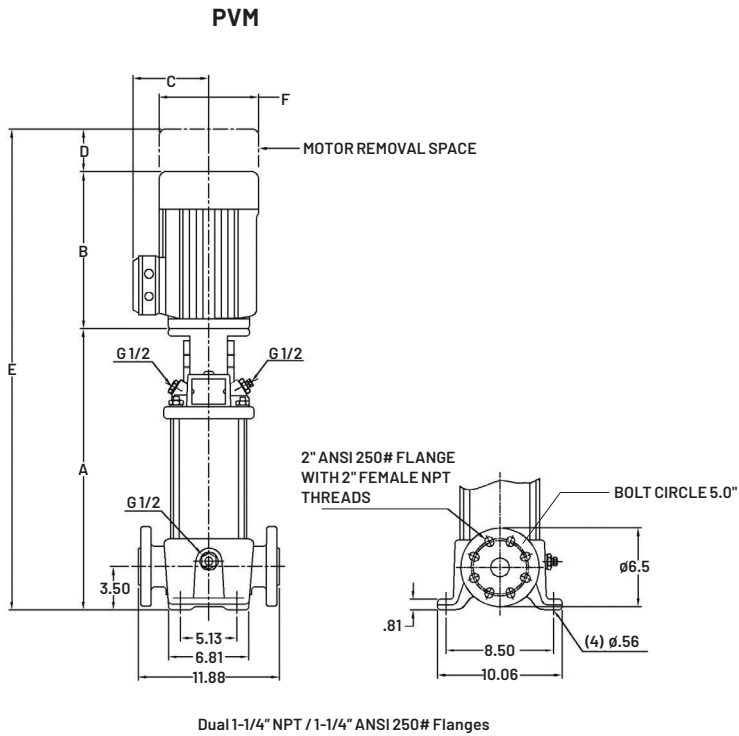

# PUMP DIMENSIONS

## PVM (X) 33 PUMP DIMENSIONS – STANDARD

MODEL NUMBER	MOTOR HP	MOTOR SERVICE FACTOR	PHASE	VOLTAGE	MOTOR FRAME	PVM CAST IRON							PVMX STAINLESS STEEL								
						DIMENSIONS IN INCHES						WEIGHT IN LBS		DIMENSIONS IN INCHES						WEIGHT IN LBS	
						A	B	C	D	E	F	PUMP END ONLY	PUMP & MOTOR	A	B	C	D	E	F	PUMP END ONLY	PUMP & MOTOR
PVM33-1-1	5	1.15	1	208-230V	213TC	20.3	15.5	9.6	3.1	38.9	9.6	130	247	20.3	15.5	9.6	3.1	38.9	9.6	130	247
PVM33-1-1	5	1.15	3	208-230V/460V	184TC	20.3	13.9	8.9	2.6	36.9	8.9	130	198	20.3	13.9	8.9	2.6	36.9	8.9	130	198
PVM33-1	5	1.15	1	208-230V	213TC	20.3	15.5	9.6	3.1	38.9	9.6	130	247	20.3	15.5	9.6	3.1	38.9	9.6	130	247
PVM33-1	5	1.15	3	208-230V/460V	184TC	20.3	13.9	8.9	2.6	36.9	8.9	130	198	20.3	13.9	8.9	2.6	36.9	8.9	130	198
PVM33-2-2	7.5	1.15	1	208-230V	213TC	21.8	15.5	8.7	3.1	40.4	8.7	132	249	21.8	15.5	8.7	3.1	40.4	8.7	132	249
PVM33-2-2	7.5	1.15	3	208-230V/460V	213TC	21.8	15.5	9.6	3.1	40.5	9.6	132	230	21.8	15.5	9.6	3.1	40.5	9.6	132	230
PVM33-2-1	7.5	1.15	1	208-230V	213TC	21.8	15.5	8.7	3.1	40.4	8.7	132	249	21.8	15.5	8.7	3.1	40.4	8.7	132	249
PVM33-2-1	7.5	1.15	3	208-230V/460V	213TC	21.8	15.5	9.6	3.1	40.5	9.6	132	230	21.8	15.5	9.6	3.1	40.5	9.6	132	230
PVM33-2	10	1.15	1	208-230V	215TC	21.8	16.6	9.6	3.1	41.5	9.6	132	267	21.8	16.6	9.6	3.1	41.5	9.6	132	267
PVM33-2	10	1.15	3	208-230V/460V	215TC	21.8	15.5	9.6	3.1	40.5	9.6	132	257	21.8	15.5	9.6	3.1	40.5	9.6	132	257
PVM33-3-2	10	1.15	1	208-230V	215TC	28.9	16.6	9.6	3.1	48.6	9.6	132	267	28.9	16.6	9.6	3.1	48.6	9.6	132	267
PVM33-3-2	10	1.15	3	208-230V/460V	215TC	28.9	15.5	9.6	3.1	47.6	9.6	132	257	28.9	15.5	9.6	3.1	47.6	9.6	132	257
PVM33-3	15	1.15	3	208-230V/460V	254TC	27.7	20.0	12.9	3.8	51.5	12.9	138	413	27.7	20.0	12.9	3.8	51.5	12.9	138	413
PVM33-4-2	15	1.15	3	208-230V/460V	254TC	30.4	20.0	12.9	3.8	54.2	12.9	138	413	30.4	20.0	12.9	3.8	54.2	12.9	138	413
PVM33-4	20	1.15	3	230V/460V	254TC	30.4	16.9	10.3	3.8	51.0	10.3	148	373	30.4	16.9	10.3	3.8	51.0	10.3	148	373
PVM33-5-2	20	1.15	3	230V/460V	254TC	33.2	16.9	10.3	3.8	53.8	10.3	162	387	33.2	16.9	10.3	3.8	53.8	10.3	162	387
PVM33-5	20	1.15	3	230V/460V	254TC	33.2	16.9	10.3	3.8	53.8	10.3	162	387	33.2	16.9	10.3	3.8	53.8	10.3	162	387
PVM33-6-2	25	1.15	3	230V/460V	284TSC	38.0	20.0	12.9	3.0	61.0	12.9	180	501	38.0	20.0	12.9	3.0	61.0	12.9	180	501
PVM33-6	25	1.15	3	230V/460V	284TSC	38.0	20.0	12.9	3.0	61.0	12.9	180	501	38.0	20.0	12.9	3.0	61.0	12.9	180	501
PVM33-7-2	30	1.15	3	230V/460V	284TSC	40.7	23.2	15.6	3.0	66.9	15.6	202	625	40.7	23.2	15.6	3.0	66.9	15.6	202	625
PVM33-7	30	1.15	3	230V/460V	284TSC	40.7	23.2	15.6	3.0	66.9	15.6	202	625	40.7	23.2	15.6	3.0	66.9	15.6	202	625
PVM33-8-2	30	1.15	3	230V/460V	284TSC	43.5	23.2	15.6	3.0	69.7	15.6	228	651	43.5	23.2	15.6	3.0	69.7	15.6	228	651
PVM33-8	40	1.15	3	230V/460V	286TSC	43.5	23.2	15.6	3.0	69.7	15.6	228	708	43.5	23.2	15.6	3.0	69.7	15.6	228	708
PVM33-9-2	40	1.15	3	230V/460V	286TSC	46.2	23.2	15.6	3.0	72.4	15.6	258	738	46.2	23.2	15.6	3.0	72.4	15.6	258	738
PVM33-9	40	1.15	3	230V/460V	286TSC	46.2	23.2	15.6	3.0	72.4	15.6	258	738	46.2	23.2	15.6	3.0	72.4	15.6	258	738
PVM33-10-2	40	1.15	3	230V/460V	286TSC	49.0	23.2	15.6	3.0	75.2	15.6	292	772	49.0	23.2	15.6	3.0	75.2	15.6	292	772

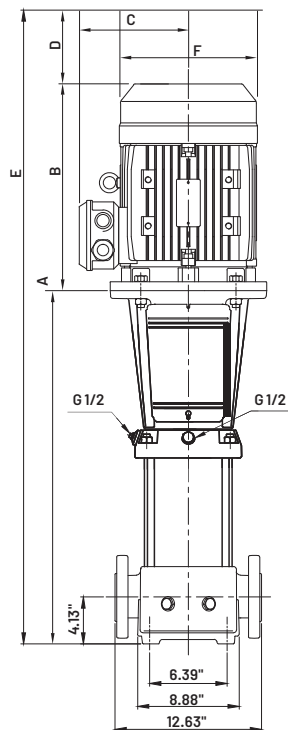

**PVM**

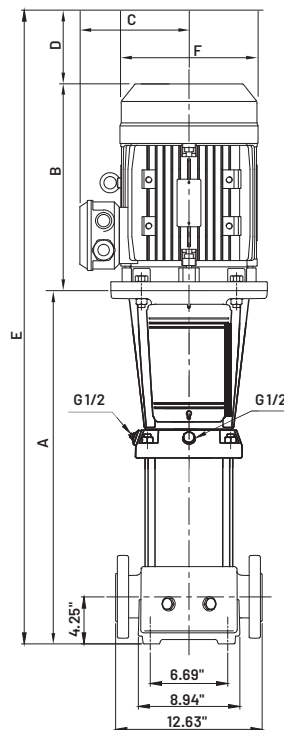
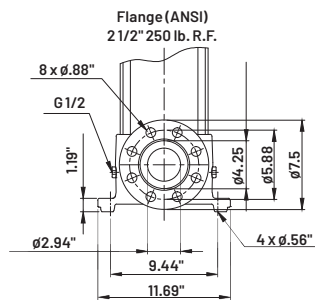

**PVMX**

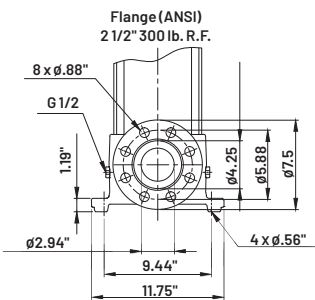

# PUMP DIMENSIONS

## PVM (X) 33 PUMP DIMENSIONS - METRIC

MODEL NUMBER	MOTOR HP	MOTOR SAFETY FACTOR	PHASE	VOLTAGE	MOTOR FRAME	PVM CAST IRON							PVMX STAINLESS STEEL								
						DIMENSIONS IN INCHES						WEIGHT IN LBS		DIMENSIONS IN INCHES						WEIGHT IN LBS	
						A	B	C	D	E	F	PUMP END ONLY	PUMP & MOTOR	A	B	C	D	E	F	PUMP END ONLY	PUMP & MOTOR
PVM33-1-1	5	1.15	1	208-230V	213TC	516	394	243	79	989	243	59	112	516	394	243	79	989	243	59	112
PVM33-1-1	5	1.15	3	208-230V/460V	184TC	516	354	225	67	936	225	59	90	516	354	225	67	936	225	59	90
PVM33-1	5	1.15	1	208-230V	213TC	516	394	243	79	989	243	59	112	516	394	243	79	989	243	59	112
PVM33-1	5	1.15	3	208-230V/460V	184TC	516	354	225	67	936	225	59	90	516	354	225	67	936	225	59	90
PVM33-2-2	7.5	1.15	1	208-230V	213TC	554	394	220	79	1027	220	60	113	554	394	220	79	1027	220	60	113
PVM33-2-2	7.5	1.15	3	208-230V/460V	213TC	554	395	243	79	1028	243	60	104	554	395	243	79	1028	243	60	104
PVM33-2-1	7.5	1.15	1	208-230V	213TC	554	394	220	79	1027	220	60	113	554	394	220	79	1027	220	60	113
PVM33-2-1	7.5	1.15	3	208-230V/460V	213TC	554	395	243	79	1028	243	60	104	554	395	243	79	1028	243	60	104
PVM33-2	10	1.15	1	208-230V	215TC	554	422	243	79	1055	243	60	121	554	422	243	79	1055	243	60	121
PVM33-2	10	1.15	3	208-230V/460V	215TC	554	394	243	79	1028	243	60	117	554	394	243	79	1028	243	60	117
PVM33-3-2	10	1.15	1	208-230V	215TC	734	422	243	79	1236	243	60	121	734	422	243	79	1236	243	60	121
PVM33-3-2	10	1.15	3	208-230V/460V	215TC	734	394	243	79	1208	243	60	117	734	394	243	79	1208	243	60	117
PVM33-3	15	1.15	3	208-230V/460V	254TC	704	509	329	95	1308	329	63	187	704	509	329	95	1308	329	63	187
PVM33-4-2	15	1.15	3	208-230V/460V	254TC	772	509	329	95	1376	329	63	187	772	509	329	95	1376	329	63	187
PVM33-4	20	1.15	3	230V/460V	254TC	772	428	263	95	1296	263	67	169	772	428	263	95	1296	263	67	169
PVM33-5-2	20	1.15	3	230V/460V	254TC	843	428	263	95	1367	263	73	176	843	428	263	95	1367	263	73	176
PVM33-5	20	1.15	3	230V/460V	254TC	843	428	263	95	1367	263	73	176	843	428	263	95	1367	263	73	176
PVM33-6-2	25	1.15	3	230V/460V	284TSC	965	507	329	76	1549	329	82	227	965	507	329	76	1549	329	82	227
PVM33-6	25	1.15	3	230V/460V	284TSC	965	507	329	76	1549	329	82	227	965	507	329	76	1549	329	82	227
PVM33-7-2	30	1.15	3	230V/460V	284TSC	1034	589	395	76	1699	395	92	283	1034	589	395	76	1699	395	92	283
PVM33-7	30	1.15	3	230V/460V	284TSC	1034	589	395	76	1699	395	92	283	1034	589	395	76	1699	395	92	283
PVM33-8-2	30	1.15	3	230V/460V	284TSC	1105	589	395	76	1770	395	103	295	1105	589	395	76	1770	395	103	295
PVM33-8	40	1.15	3	230V/460V	286TSC	1105	589	395	76	1770	395	103	321	1105	589	395	76	1770	395	103	321
PVM33-9-2	40	1.15	3	230V/460V	286TSC	1173	589	395	76	1839	395	117	335	1173	589	395	76	1839	395	117	335
PVM33-9	40	1.15	3	230V/460V	286TSC	1173	589	395	76	1839	395	117	335	1173	589	395	76	1839	395	117	335
PVM33-10-2	40	1.15	3	230V/460V	286TSC	1245	589	395	76	1910	395	132	350	1245	589	395	76	1910	395	132	350

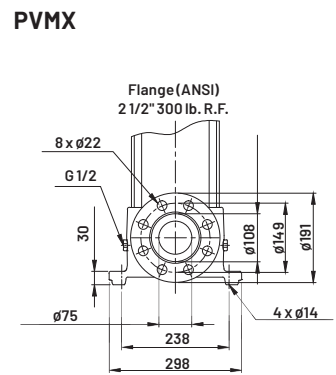
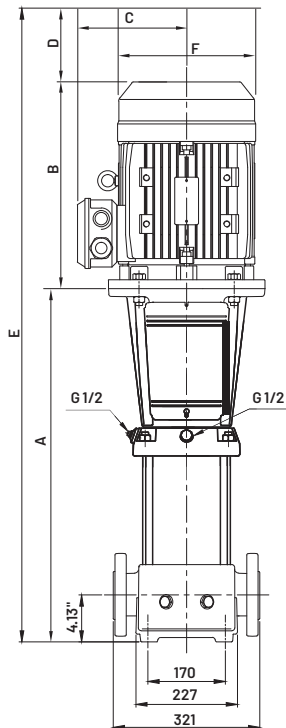
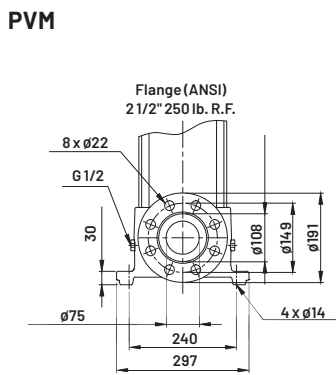
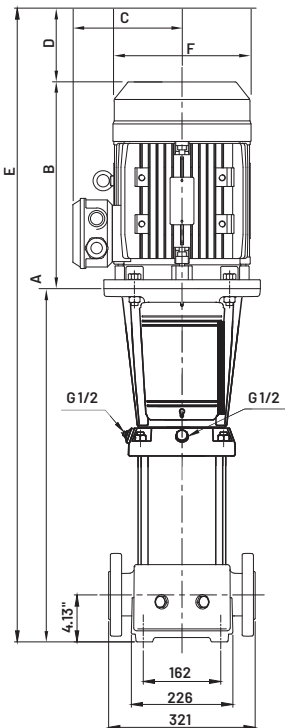

# PUMP DIMENSIONS

## PVM (X) 45 PUMP DIMENSIONS – STANDARD

MODEL NUMBER	MOTOR HP	MOTOR SERVICE FACTOR	PHASE	VOLTAGE	MOTOR FRAME	PVM CAST IRON							PVMX STAINLESS STEEL								
						DIMENSIONS IN INCHES						WEIGHT IN LBS		DIMENSIONS IN INCHES						WEIGHT IN LBS	
						A	B	C	D	E	F	PUMP END ONLY	PUMP & MOTOR	A	B	C	D	E	F	PUMP END ONLY	PUMP & MOTOR
PVM45-1-1	7.5	1.15	1	208-230V	213TC	21.3	15.5	8.7	3.1	39.9	8.7	143	260	21.2	15.5	8.7	3.1	39.8	8.7	124	241
PVM45-1-1	7.5	1.15	3	208-230V/460V	213TC	21.3	15.5	9.6	3.1	40.0	9.6	143	241	21.2	15.5	9.6	3.1	39.9	9.6	124	222
PVM45-1	10	1.15	1	208-230V	215TC	21.3	16.6	9.6	3.1	41.0	9.6	143	278	21.2	16.6	9.6	3.1	40.9	9.6	124	259
PVM45-1	10	1.15	3	208-230V/460V	215TC	21.3	15.5	9.6	3.1	40.0	9.6	143	268	21.2	15.5	9.6	3.1	39.9	9.6	124	249
PVM45-2-2	15	1.15	3	208-230V/460V	254TC	27.6	20.0	12.9	3.8	51.4	12.9	172	447	27.5	20.0	12.9	3.8	51.3	12.9	154	429
PVM45-2-1	15	1.15	3	208-230V/460V	254TC	27.6	20.0	12.9	3.8	51.4	12.9	172	447	27.5	20.0	12.9	3.8	51.3	12.9	154	429
PVM45-2	15	1.15	3	230V/460V	254TC	30.4	16.9	10.3	3.8	51.0	10.3	172	397	27.5	16.9	10.3	3.8	48.1	10.3	154	379
PVM45-3-2	20	1.15	3	230V/460V	254TC	32.7	20.0	12.9	3.8	56.4	12.9	180	501	32.6	20.0	12.9	3.8	56.3	12.9	162	483
PVM45-3-1	25	1.15	3	230V/460V	284TSC	32.7	20.0	12.9	3.0	55.7	12.9	183	504	32.6	20.0	12.9	3.0	55.6	12.9	164	485
PVM45-3	25	1.15	3	230V/460V	284TSC	32.7	20.0	12.9	3.0	55.7	12.9	183	504	32.6	20.0	12.9	3.0	55.6	12.9	164	485
PVM45-4-2	30	1.15	3	230V/460V	284TSC	35.9	23.2	15.6	3.0	62.1	15.6	191	614	35.8	23.2	15.6	3.0	62.0	15.6	172	595
PVM45-4-1	30	1.15	3	230V/460V	284TSC	35.9	23.2	15.6	3.0	62.1	15.6	191	614	35.8	23.2	15.6	3.0	62.0	15.6	172	595
PVM45-4	30	1.15	3	230V/460V	284TSC	35.9	23.2	15.6	3.0	62.1	15.6	191	614	35.8	23.2	15.6	3.0	62.0	15.6	172	595
PVM45-5-2	40	1.15	3	230V/460V	286TSC	39.0	23.2	15.6	3.0	65.2	15.6	199	679	38.9	23.2	15.6	3.0	65.1	15.6	180	660
PVM45-5-1	40	1.15	3	230V/460V	286TSC	39.0	23.2	15.6	3.0	65.2	15.6	199	679	38.9	23.2	15.6	3.0	65.1	15.6	180	660
PVM45-5	40	1.15	3	230V/460V	286TSC	39.0	23.2	15.6	3.0	65.2	15.6	199	679	38.9	23.2	15.6	3.0	65.1	15.6	180	660
PVM45-6-2	50	1.15	3(TEFC)	230V/460V	326TSC	42.2	28.8	16.5	3.5	74.5	16.5	224	724	42.1	28.8	16.5	3.5	74.4	16.5	205	705
PVM45-6-2	50	1.15	3(ODP)	230V/460V	324TSC	42.2	25.7	16.5	3.5	71.4	16.5	224	603	42.1	25.7	16.5	3.5	71.3	16.5	206	585
PVM45-6	50	1.15	3(TEFC)	230V/460V	326TSC	42.2	28.8	16.5	3.5	74.5	16.5	232	732	42.1	28.8	16.5	3.5	74.4	16.5	206	706
PVM45-6	50	1.15	3(ODP)	230V/460V	324TSC	42.2	25.7	16.5	3.5	71.4	16.5	232	611	42.1	25.7	16.5	3.5	71.3	16.5	206	585
PVM45-7-2	50	1.15	3(TEFC)	230V/460V	326TSC	45.3	28.8	16.5	3.5	77.6	16.5	232	732	45.2	28.8	16.5	3.5	77.5	16.5	214	714
PVM45-7-2	50	1.15	3(ODP)	230V/460V	324TSC	45.3	25.7	16.5	3.5	74.5	16.5	232	611	45.2	25.7	16.5	3.5	74.4	16.5	214	593
PVM45-7	60	1.15	3(TEFC)	230V/460V	364TSC	45.3	31.4	18.5	3.5	80.2	18.5	232	916	45.2	31.4	18.5	3.5	80.1	18.5	214	898
PVM45-7	60	1.15	3(ODP)	230V/460V	324TSC	45.3	25.7	18.5	3.5	74.5	18.5	232	621	45.2	25.7	18.5	3.5	74.4	18.5	214	603
PVM45-8-2	60	1.15	3(TEFC)	230V/460V	364TSC	48.4	31.4	18.5	3.5	83.3	18.5	232	916	48.3	31.4	18.5	3.5	83.2	18.5	222	906
PVM45-8-2	60	1.15	3(ODP)	230V/460V	324TSC	48.4	25.7	18.5	3.5	77.6	18.5	232	621	48.3	25.7	18.5	3.5	77.5	18.5	222	611

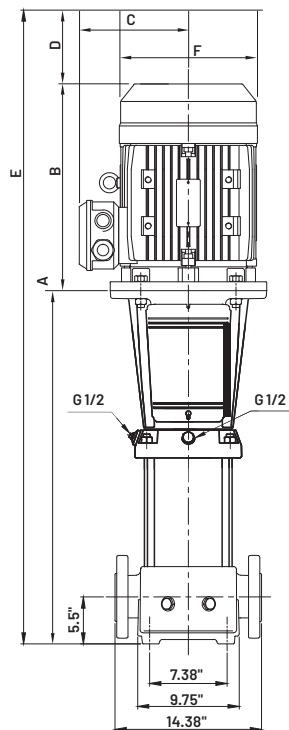

PVM

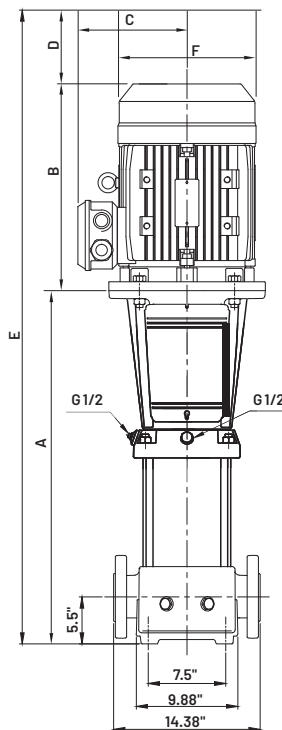
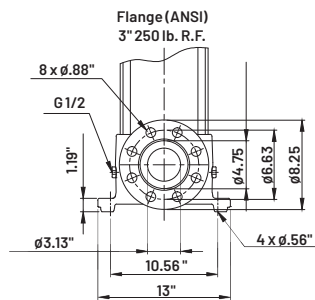

PVMX

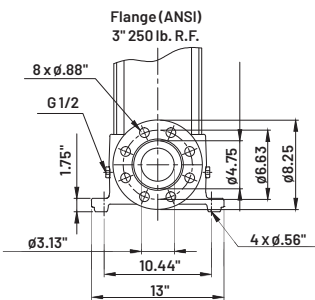

# PUMP DIMENSIONS

## PVM (X) 45 PUMP DIMENSIONS - METRIC

MODEL NUMBER	MOTOR HP	MOTOR SERVICE FACTOR	PHASE	VOLTAGE	MOTOR FRAME	PVM CAST IRON							PVMX STAINLESS STEEL								
						DIMENSIONS IN MM						WEIGHT IN KGS		DIMENSIONS IN MM						WEIGHT IN KGS	
						A	B	C	D	E	F	PUMP END ONLY	PUMP & MOTOR	A	B	C	D	E	F	PUMP END ONLY	PUMP & MOTOR
PVM45-1-1	7.5	1.15	1	208-230V	213TC	541	394	220	79	1014	220	65	118	538	394	220	79	1012	220	56	109
PVM45-1-1	7.5	1.15	3	208-230V/460V	213TC	541	395	243	79	1015	243	65	109	538	395	243	79	1013	243	56	101
PVM45-1	10	1.15	1	208-230V	215TC	541	422	243	79	1043	243	65	126	538	422	243	79	1040	243	56	117
PVM45-1	10	1.15	3	208-230V/460V	215TC	541	394	243	79	1015	243	65	122	538	394	243	79	1012	243	56	113
PVM45-2-2	15	1.15	3	208-230V/460V	254TC	701	509	329	95	1305	329	78	203	699	509	329	95	1303	329	70	195
PVM45-2-1	15	1.15	3	208-230V/460V	254TC	701	509	329	95	1305	329	78	203	699	509	329	95	1303	329	70	195
PVM45-2	15	1.15	3	230V/460V	254TC	772	428	263	95	1296	263	78	180	699	428	263	95	1222	263	70	172
PVM45-3-2	20	1.15	3	230V/460V	254TC	831	507	329	95	1433	329	82	227	828	507	329	95	1431	329	73	219
PVM45-3-1	25	1.15	3	230V/460V	284TSC	831	507	329	76	1414	329	83	229	828	507	329	76	1411	329	74	220
PVM45-3	25	1.15	3	230V/460V	284TSC	831	507	329	76	1414	329	83	229	828	507	329	76	1411	329	74	220
PVM45-4-2	30	1.15	3	230V/460V	284TSC	912	589	395	76	1577	395	87	278	909	589	395	76	1575	395	78	270
PVM45-4-1	30	1.15	3	230V/460V	284TSC	912	589	395	76	1577	395	87	278	909	589	395	76	1575	395	78	270
PVM45-4	30	1.15	3	230V/460V	284TSC	912	589	395	76	1577	395	87	278	909	589	395	76	1575	395	78	270
PVM45-5-2	40	1.15	3	230V/460V	286TSC	991	589	395	76	1656	395	90	308	988	589	395	76	1653	395	82	299
PVM45-5-1	40	1.15	3	230V/460V	286TSC	991	589	395	76	1656	395	90	308	988	589	395	76	1653	395	82	299
PVM45-5	40	1.15	3	230V/460V	286TSC	991	589	395	76	1656	395	90	308	988	589	395	76	1653	395	82	299
PVM45-6-2	50	1.15	3(TEFC)	230V/460V	326TSC	1072	731	419	89	1892	419	102	328	1069	731	419	89	1889	419	93	320
PVM45-6-2	50	1.15	3(ODP)	230V/460V	324TSC	1072	653	419	89	1813	419	102	273	1069	653	419	89	1811	419	93	265
PVM45-6	50	1.15	3(TEFC)	230V/460V	326TSC	1072	731	419	89	1892	419	105	332	1069	731	419	89	1889	419	93	320
PVM45-6	50	1.15	3(ODP)	230V/460V	324TSC	1072	653	419	89	1813	419	105	277	1069	653	419	89	1811	419	93	265
PVM45-7-2	50	1.15	3(TEFC)	230V/460V	326TSC	1151	731	419	89	1971	419	105	332	1148	731	419	89	1968	419	97	324
PVM45-7-2	50	1.15	3(ODP)	230V/460V	324TSC	1151	653	419	89	1892	419	105	277	1148	653	419	89	1890	419	97	269
PVM45-7	60	1.15	3(TEFC)	230V/460V	364TSC	1151	797	470	89	2036	470	105	415	1148	797	470	89	2034	470	97	407
PVM45-7	60	1.15	3(ODP)	230V/460V	324TSC	1151	653	470	89	1892	470	105	282	1148	653	470	89	1890	470	97	273
PVM45-8-2	60	1.15	3(TEFC)	230V/460V	364TSC	1229	797	470	89	2115	470	105	415	1227	797	470	89	2112	470	101	411
PVM45-8-2	60	1.15	3(ODP)	230V/460V	324TSC	1229	653	470	89	1971	470	105	282	1227	653	470	89	1968	470	101	277

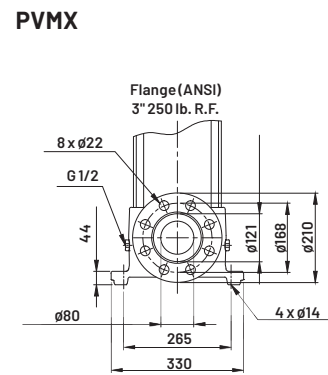
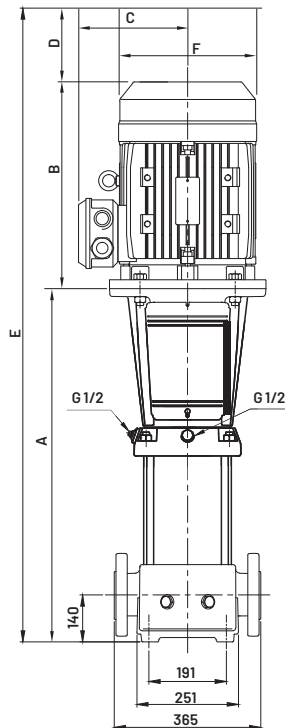
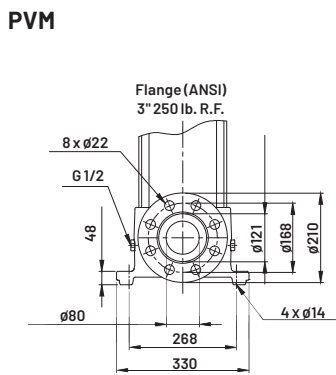
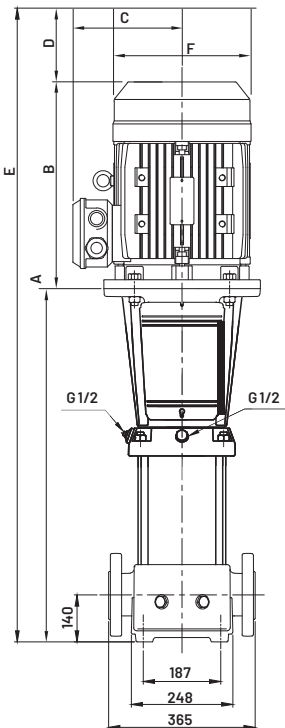

# PUMP DIMENSIONS

## PVM (X) 64 PUMP DIMENSIONS – STANDARD

MODEL NUMBER	MOTOR HP	MOTOR SERVICE FACTOR	PHASE	VOLTAGE	MOTOR FRAME	PVM CAST IRON							PVMX STAINLESS STEEL								
						DIMENSIONS IN INCHES						WEIGHT IN LBS		DIMENSIONS IN INCHES						WEIGHT IN LBS	
						A	B	C	D	E	F	PUMP END ONLY	PUMP & MOTOR	A	B	C	D	E	F	PUMP END ONLY	PUMP & MOTOR
PVM64-1-1	10	1.15	1	208-230V	215TC	21.4	16.6	9.6	3.1	41.1	9.6	130	265	21.4	16.6	9.6	3.1	41.1	9.6	115	250
PVM64-1-1	10	1.15	3	208-230V/460V	215TC	21.4	15.5	9.6	3.1	40.1	9.6	130	255	21.4	15.5	9.6	3.1	40.1	9.6	115	240
PVM64-1	15	1.15	3	208-230V/460V	254TC	24.5	20.0	12.9	3.8	48.3	12.9	151	426	24.5	20.0	12.9	3.8	48.3	12.9	136	411
PVM64-2-2	20	1.15	3	230V/460V	254TC	27.8	16.9	10.3	3.8	48.4	10.3	160	385	27.8	16.9	10.3	3.8	48.4	10.3	145	370
PVM64-2-1	20	1.15	3	230V/460V	254TC	27.8	16.9	10.3	3.8	48.4	10.3	160	385	27.8	16.9	10.3	3.8	48.4	10.3	145	370
PVM64-2	25	1.15	3	230V/460V	284TSC	29.8	20.0	12.9	3.0	52.8	12.9	162	483	29.8	20.0	12.9	3.0	52.8	12.9	147	468
PVM64-3-2	30	1.15	3	230V/460V	284TSC	33.0	23.2	15.6	3.0	59.2	15.6	172	595	33.0	23.2	15.6	3.0	59.2	15.6	156	579
PVM64-3-1	40	1.15	3	230V/460V	286TSC	33.0	23.2	15.6	3.0	59.2	15.6	172	652	33.0	23.2	15.6	3.0	59.2	15.6	156	636
PVM64-3	40	1.15	3	230V/460V	286TSC	33.0	23.2	15.6	3.0	59.2	15.6	172	652	33.0	23.2	15.6	3.0	59.2	15.6	156	636
PVM64-4-2	40	1.15	3	230V/460V	286TSC	36.3	23.2	15.6	3.0	62.5	15.6	180	660	36.3	23.2	15.6	3.0	62.5	15.6	156	636
PVM64-4-1	50	1.15	3(TEFC)	230V/460V	326TSC	36.3	28.8	16.5	3.5	68.6	16.5	198	698	36.3	28.8	16.5	3.5	68.6	16.5	182	682
PVM64-4-1	50	1.15	3(ODP)	230V/460V	324TSC	36.3	25.7	16.5	3.5	65.5	16.5	198	577	36.3	25.7	16.5	3.5	65.5	16.5	182	561
PVM64-4	50	1.15	3(TEFC)	230V/460V	326TSC	36.4	28.8	16.5	3.5	68.7	16.5	198	698	36.4	28.8	16.5	3.5	68.7	16.5	182	682
PVM64-4	50	1.15	3(ODP)	230V/460V	324TSC	36.4	25.7	16.5	3.5	65.6	16.5	198	577	36.4	25.7	16.5	3.5	65.6	16.5	182	561
PVM64-5-2	60	1.15	3(TEFC)	230V/460V	364TSC	39.6	31.4	18.5	3.5	74.5	18.5	206	890	39.6	31.4	18.5	3.5	74.5	18.5	182	866
PVM64-5-2	60	1.15	3(ODP)	230V/460V	324TSC	39.6	25.7	18.5	3.5	68.8	18.5	206	595	39.6	25.7	18.5	3.5	68.8	18.5	182	571

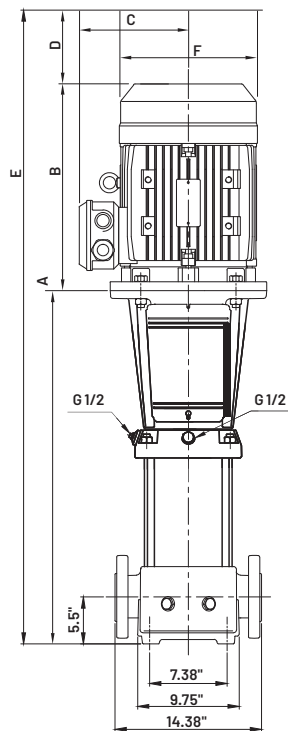

**PVM**

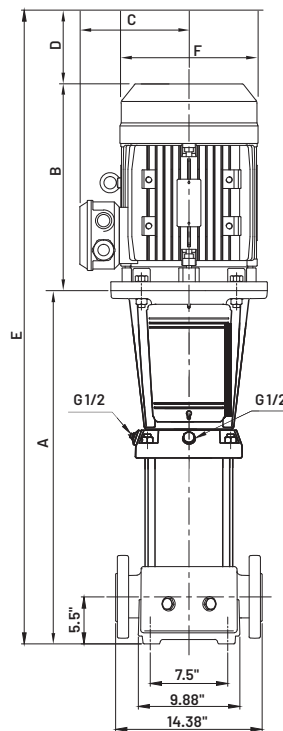
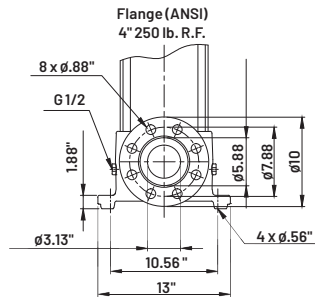

**PVMX**

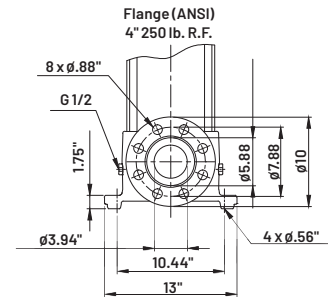

# PUMP DIMENSIONS

## PVM (X) 64 PUMP DIMENSIONS - METRIC

MODEL NUMBER	MOTOR HP	MOTOR SERVICE FACTOR	PHASE	VOLTAGE	MOTOR FRAME	PVM CAST IRON							PVMX STAINLESS STEEL								
						DIMENSIONS IN MM						WEIGHT IN KGS		DIMENSIONS IN MM						WEIGHT IN KGS	
						A	B	C	D	E	F	PUMP END ONLY	PUMP & MOTOR	A	B	C	D	E	F	PUMP END ONLY	PUMP & MOTOR
PVM64-1-1	10	1.15	1	208-230V	215TC	544	422	243	79	1045	243	59	120	544	422	243	79	1045	243	52	113
PVM64-1-1	10	1.15	3	208-230V/460V	215TC	544	394	243	79	1017	243	59	116	544	394	243	79	1017	243	52	109
PVM64-1	15	1.15	3	208-230V/460V	254TC	622	509	329	95	1226	329	68	193	622	509	329	95	1226	329	62	186
PVM64-2-2	20	1.15	3	230V/460V	254TC	706	428	263	95	1230	263	73	175	706	428	263	95	1230	263	66	168
PVM64-2-1	20	1.15	3	230V/460V	254TC	706	428	263	95	1230	263	73	175	706	428	263	95	1230	263	66	168
PVM64-2	25	1.15	3	230V/460V	284TSC	757	507	329	76	1340	329	73	219	757	507	329	76	1340	329	67	212
PVM64-3-2	30	1.15	3	230V/460V	284TSC	838	589	395	76	1503	395	78	270	838	589	395	76	1503	395	71	263
PVM64-3-1	40	1.15	3	230V/460V	286TSC	838	589	395	76	1503	395	78	296	838	589	395	76	1503	395	71	288
PVM64-3	40	1.15	3	230V/460V	286TSC	838	589	395	76	1503	395	78	296	838	589	395	76	1503	395	71	288
PVM64-4-2	40	1.15	3	230V/460V	286TSC	922	589	395	76	1587	395	82	299	922	589	395	76	1587	395	71	288
PVM64-4-1	50	1.15	3(TEFC)	230V/460V	326TSC	922	731	419	89	1742	419	90	317	922	731	419	89	1742	419	83	309
PVM64-4-1	50	1.15	3(ODP)	230V/460V	324TSC	922	653	419	89	1663	419	90	262	922	653	419	89	1663	419	83	254
PVM64-4	50	1.15	3(TEFC)	230V/460V	326TSC	925	731	419	89	1744	419	90	317	925	731	419	89	1744	419	83	309
PVM64-4	50	1.15	3(ODP)	230V/460V	324TSC	925	653	419	89	1666	419	90	262	925	653	419	89	1666	419	83	254
PVM64-5-2	60	1.15	3(TEFC)	230V/460V	364TSC	1006	797	470	89	1891	470	93	404	1006	797	470	89	1891	470	83	393
PVM64-5-2	60	1.15	3(ODP)	230V/460V	324TSC	1006	653	470	89	1747	470	93	270	1006	653	470	89	1747	470	83	259

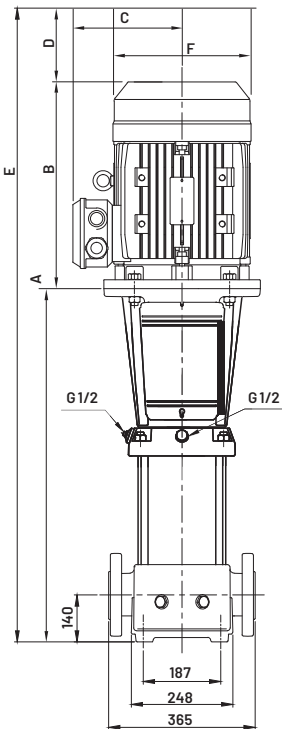

**PVM**

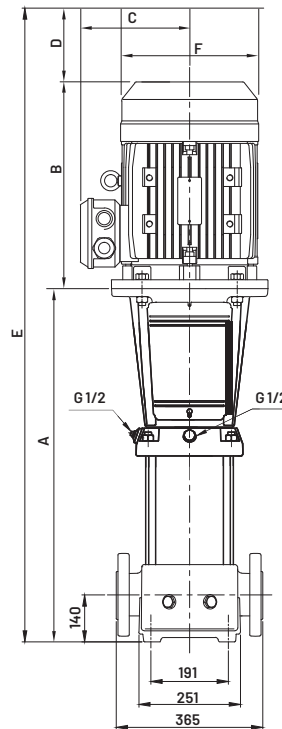
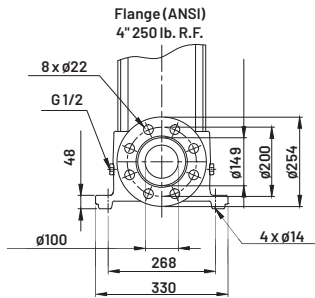

**PVMX**

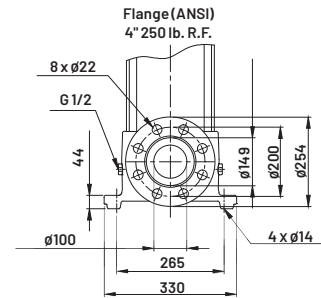

# PUMP DIMENSIONS

## PVM (X) 90 PUMP DIMENSIONS – STANDARD

MODEL NUMBER	MOTOR HP	MOTOR SERVICE FACTOR	PHASE	VOLTAGE	MOTOR FRAME	PVM CAST IRON								PVMX STAINLESS STEEL							
						DIMENSIONS IN INCHES						WEIGHT IN LBS		DIMENSIONS IN INCHES						WEIGHT IN LBS	
						A	B	C	D	E	F	PUMP END ONLY	PUMP & MOTOR	A	B	C	D	E	F	PUMP END ONLY	PUMP & MOTOR
PVM90-1-1	15	1.15	3	208-230V/460V	254TC	24.9	20.0	12.9	3.8	48.7	12.9	181	456	25.0	20.0	12.9	3.8	48.8	12.9	159	434
PVM90-1	20	1.15	3	230V/460V	254TC	24.9	16.9	10.3	3.8	45.5	10.3	181	406	25.0	16.9	10.3	3.8	45.6	10.3	159	384
PVM90-2-2	25	1.15	3	230V/460V	284TSC	30.5	20.0	12.9	3.0	53.5	12.9	194	515	30.6	20.0	12.9	3.0	53.6	12.9	172	493
PVM90-2-1	30	1.15	3	230V/460V	284TSC	30.5	23.2	15.6	3.0	56.7	15.6	194	617	30.6	23.2	15.6	3.0	56.8	15.6	172	595
PVM90-2	40	1.15	3	230V/460V	286TSC	30.5	23.2	15.6	3.0	56.7	15.6	194	674	30.6	23.2	15.6	3.0	56.8	15.6	172	652
PVM90-3-2	40	1.15	3	230V/460V	286TSC	34.1	23.2	15.6	3.0	60.3	15.6	205	685	34.3	23.2	15.6	3.0	60.5	15.6	184	664
PVM90-3-1	50	1.15	3 (TEFC)	230V/460V	326TSC	34.1	28.8	16.5	3.5	66.4	16.5	223	723	34.3	28.8	16.5	3.5	66.6	16.5	201	701
PVM90-3-1	50	1.15	3 (ODP)	230V/460V	324TSC	34.1	25.7	16.5	3.5	63.3	16.5	223	602	34.3	25.7	16.5	3.5	63.5	16.5	201	580
PVM90-3	50	1.15	3 (TEFC)	230V/460V	326TSC	34.1	28.8	16.5	3.5	66.4	16.5	223	723	34.3	28.8	16.5	3.5	66.6	16.5	201	701
PVM90-3	50	1.15	3 (ODP)	230V/460V	324TSC	34.1	25.7	16.5	3.5	63.3	16.5	223	602	34.3	25.7	16.5	3.5	63.5	16.5	201	580
PVM90-4-2	60	1.15	3 (TEFC)	230V/460V	364TSC	37.7	31.4	18.5	3.5	72.6	18.5	238	922	37.9	31.4	18.5	3.5	72.8	18.5	216	900
PVM90-4-2	60	1.15	3 (ODP)	230V/460V	324TSC	37.7	25.7	18.5	3.5	66.9	18.5	238	627	37.9	25.7	18.5	3.5	67.1	18.5	216	605
PVM90-4-1	60	1.15	3 (TEFC)	230V/460V	364TSC	37.7	31.4	18.5	3.5	72.6	18.5	238	922	40.9	31.4	18.5	3.5	75.8	18.5	216	900
PVM90-4-1	60	1.15	3 (ODP)	230V/460V	324TSC	37.7	25.7	18.5	3.5	66.9	18.5	238	627	40.9	25.7	18.5	3.5	70.1	18.5	216	605

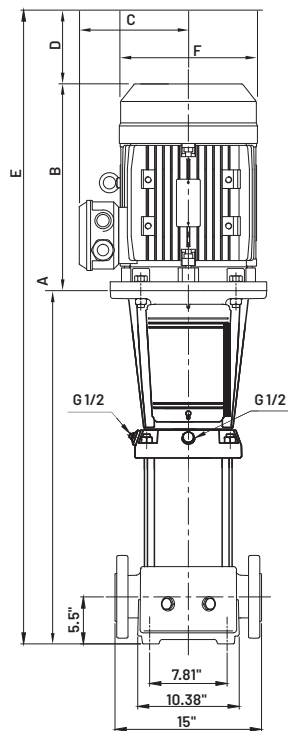

PVM

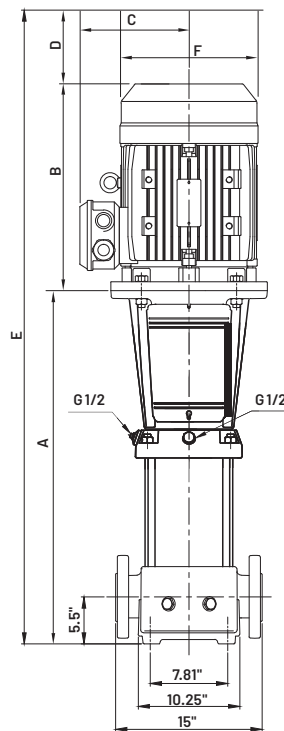
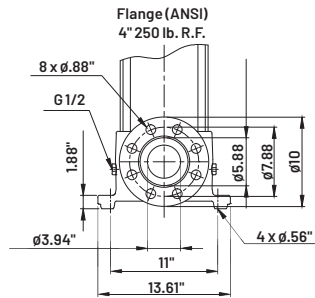

PVMX

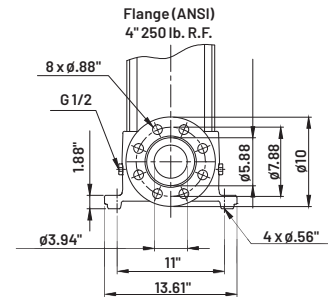

# PUMP DIMENSIONS

## PVM (X) 90 PUMP DIMENSIONS - METRIC

MODEL NUMBER	MOTOR HP	MOTOR SERVICE FACTOR	PHASE	VOLTAGE	MOTOR FRAME	PVM CAST IRON							PVMX STAINLESS STEEL								
						DIMENSIONS IN MM						WEIGHT IN KGS		DIMENSIONS IN MM						WEIGHT IN KGS	
						A	B	C	D	E	F	PUMP END ONLY	PUMP & MOTOR	A	B	C	D	E	F	PUMP END ONLY	PUMP & MOTOR
PVM90-1-1	15	1.15	3	208-230V/460V	254TC	632	509	329	95	1236	329	82	207	635	509	329	95	1239	329	72	197
PVM90-1	20	1.15	3	230V/460V	254TC	632	428	263	95	1156	263	82	184	635	428	263	95	1158	263	72	174
PVM90-2-2	25	1.15	3	230V/460V	284TSC	775	507	329	76	1358	329	88	234	777	507	329	76	1361	329	78	224
PVM90-2-1	30	1.15	3	230V/460V	284TSC	775	589	395	76	1440	395	88	280	777	589	395	76	1442	395	78	270
PVM90-2	40	1.15	3	230V/460V	286TSC	775	589	395	76	1440	395	88	306	777	589	395	76	1442	395	78	296
PVM90-3-2	40	1.15	3	230V/460V	286TSC	866	589	395	76	1531	395	93	311	871	589	395	76	1536	395	83	301
PVM90-3-1	50	1.15	3(TEFC)	230V/460V	326TSC	866	731	419	89	1686	419	101	328	871	731	419	89	1691	419	91	318
PVM90-3-1	50	1.15	3(ODP)	230V/460V	324TSC	866	653	419	89	1608	419	101	273	871	653	419	89	1613	419	91	263
PVM90-3	50	1.15	3(TEFC)	230V/460V	326TSC	866	731	419	89	1686	419	101	328	871	731	419	89	1691	419	91	318
PVM90-3	50	1.15	3(ODP)	230V/460V	324TSC	866	653	419	89	1608	419	101	273	871	653	419	89	1613	419	91	263
PVM90-4-2	60	1.15	3(TEFC)	230V/460V	364TSC	958	797	470	89	1843	470	108	418	963	797	470	89	1848	470	98	408
PVM90-4-2	60	1.15	3(ODP)	230V/460V	324TSC	958	653	470	89	1699	470	108	284	963	653	470	89	1704	470	98	274
PVM90-4-1	60	1.15	3(TEFC)	230V/460V	364TSC	958	797	470	89	1843	470	108	418	1039	797	470	89	1924	470	98	408
PVM90-4-1	60	1.15	3(ODP)	230V/460V	324TSC	958	653	470	89	1699	470	108	284	1039	653	470	89	1780	470	98	274

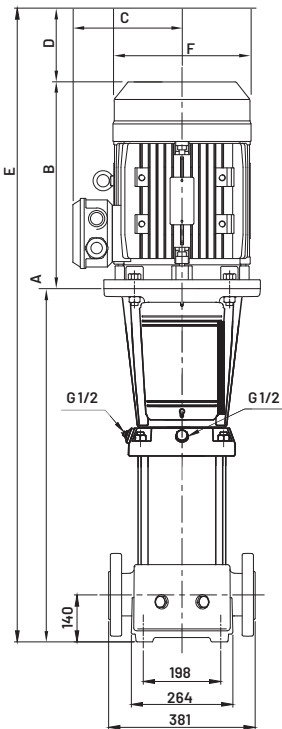

PVM

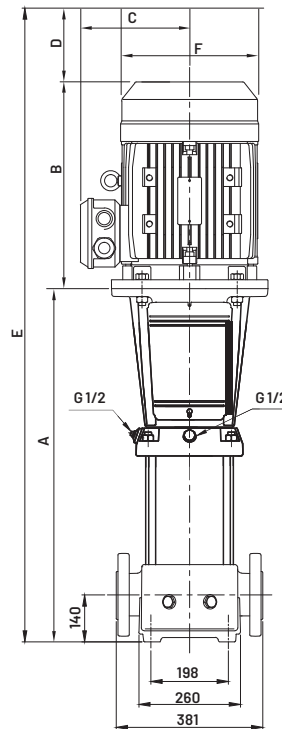
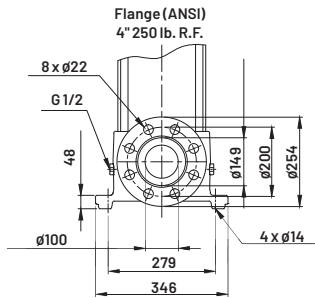

PVMX

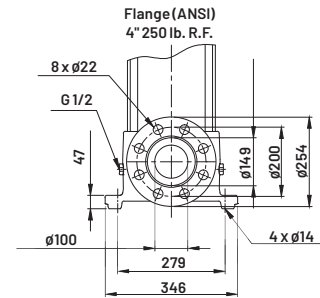

## WARRANTY

---

Seller warrants equipment (and its component parts) of its own manufacture against defects in materials and workmanship under normal use and service for one (1) year from the date of installation or start-up, or for eighteen (18) months after the date of shipment, whichever occurs first. Seller does not warrant accessories or components that are not manufactured by Seller; however, to the extent possible, Seller agrees to assign to Buyer its rights under the original manufacturer's warranty, without recourse to Seller. Buyer must give Seller notice in writing of any alleged defect covered by this warranty (together with all identifying details, including the serial number, the type of equipment, and the date of purchase) within thirty (30) days of the discovery of such defect during the warranty period. No claim made more than 30 days after the expiration of the warranty period shall be valid. Guarantees of performance and warranties are based on the use of original equipment manufactured (OEM) replacement parts. Seller assumes no responsibility or liability if alterations, non-authorized design modifications and/or non-OEM replacement parts are incorporated. If requested by Seller, any equipment (or its component parts) must be promptly returned to Seller prior to any attempted repair, or sent to an authorized service station designated by Seller, and Buyer shall prepay all shipping expenses. Seller shall not be liable for any loss or damage to goods in transit, nor will any warranty claim be valid unless the returned goods are received intact and undamaged as a result of shipment. Repaired or replaced material returned to customer will be shipped F.O.B., Seller's factory. Seller will not give Buyer credit for parts or equipment returned to Seller, and will not accept delivery of any such parts or equipment, unless Buyer has obtained Seller's approval in writing. The warranty extends to repaired or replaced parts of Seller's manufacture for ninety (90) days or for the remainder of the original warranty period applicable to the equipment or parts being repaired or replaced, whichever is greater. This warranty applies to the repaired or replaced part and is not extended to the product or any other component of the product being repaired. Repair parts of its own manufacture sold after the original warranty period are warranted for a period of one (1) year from shipment against defects in materials and workmanship under normal use and service. This warranty applies to the replacement part only and is not extended to the product or any other component of the product being repaired. Seller may substitute new equipment or improve part(s) of any equipment judged defective without further liability. All repairs or services performed by Seller, which are not covered by this warranty, will be charged in accordance with Seller's standard prices then in effect.

THIS WARRANTY IS THE SOLE WARRANTY OF SELLER AND SELLER HEREBY EXPRESSLY DISCLAIMS AND BUYER WAIVES ALL OTHER WARRANTIES EXPRESSED, IMPLIED IN LAW OR IMPLIED IN FACT, INCLUDING ANY WARRANTIES OF MERCHANTABILITY OR FITNESS FOR A PARTICULAR PURPOSE. Seller's sole obligation under this warranty shall be, at its option, to repair or replace any equipment (or its component parts) which has a defect covered by this warranty, or to refund the purchase price of such equipment or part. Under the terms of this warranty, Seller shall not be liable for (a) consequential, collateral, special or liquidated losses or damages; (b) equipment conditions caused by normal wear and tear, abnormal conditions of use, accident, neglect, or misuse of said equipment; (c) the expense of, and loss or damage caused by, repairs or alterations made by anyone other than the Seller; (d) damage caused by abrasive materials, chemicals, scale deposits, corrosion, lightning, improper voltage, mishandling, or other similar conditions; (e) any loss, damage, or expense relating to or resulting from installation, removal or reinstallation of equipment; (f) any labor costs or charges incurred in repairing or replacing defective equipment or parts, including the cost of reinstalling parts that are repaired or replaced by Seller; (g) any expense of shipment of equipment or repaired or replacement parts; or (h) any other loss, damage or expense of any nature.

The above warranty shall not apply to any equipment which may be separately covered by any alternate or special warranties.

PERFORMANCE: In the absence of Certified Pump Performance Tests, equipment performance is not warranted or guaranteed. Performance curves and other information submitted to Buyer are approximate and no warranty or guarantee shall be deemed to arise as a result of such submittal. All testing shall be done in accordance with Seller's standard policy under Hydraulic Institute procedures. LIABILITY LIMITATIONS: Under no circumstances shall the Seller have any liability under the Order or otherwise for liquidated damages or for collateral, consequential or special damages or for loss of profits, or for actual losses or for loss of production or progress of construction, regardless of the cause of such damages or losses. In any event, Seller's aggregate total liability under the Order or otherwise shall not exceed the contract price.

ACTS OF GOD: Seller shall in no event be liable for delays in delivery of the equipment or other failures to perform caused by fires, acts of God, strikes, labor difficulties, acts of governmental or military authorities, delays in transportation or procuring materials, or causes of any kind beyond Seller's control.

COMPLIANCE WITH LAW: Seller agrees to comply with all United States laws and regulations applicable to the manufacturing of the subject equipment. Such compliance shall include: The Fair Labor Standards Acts of 1938, as amended; Equal Employment Opportunity clauses of Executive Order 11246, as amended; Occupational Safety and Health Act of 1970 and the standards promulgated thereunder, if applicable. Since compliance with the various Federal, State, and Local laws and regulations concerning occupational health and safety, pollution or local codes are affected by the use, installation and operation of the equipment and other matters over which Seller has no control, Seller assumes no responsibility for compliance with those laws and regulations, whether by way of indemnity, warranty, or otherwise. It is incumbent upon the Buyer to specify equipment which complies with local codes and ordinances.



**800 Airport Road | North Aurora, Illinois | 630-859-7000 | [pentair.com](http://pentair.com)**

All indicated Pentair trademarks and logos are property of Pentair. Third party registered and unregistered trademarks and logos are the property of their respective owners. Because we are continuously improving our products and services, Pentair reserves the right to change specifications without prior notice. Pentair is an equal opportunity employer.

A-03-366(07-29-20) ©2020 Pentair. All Rights Reserved.